

# Hydrogen and Fuel Cells (H<sub>2</sub>FC) Program

*Enabling Hydrogen Technologies with Science and  
Engineering*

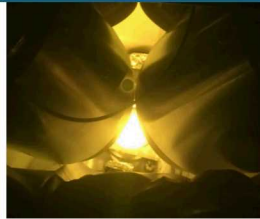
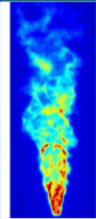

PRESENTED BY

Jonathan Zimmerman ([jzimmer@sandia.gov](mailto:jzimmer@sandia.gov))



Sandia National Laboratories is a multimission laboratory managed and operated by National Technology & Engineering Solutions of Sandia, LLC, a wholly owned subsidiary of Honeywell International Inc., for the U.S. Department of Energy's National Nuclear Security Administration under contract DE-NA0003525.

## 2 History of Hydrogen Sciences at Sandia

Sandia's core mission to support the nuclear deterrent has enabled science and engineering for energy programs

### EXPERIMENTAL HYDROGEN PIPELINE FACILITY

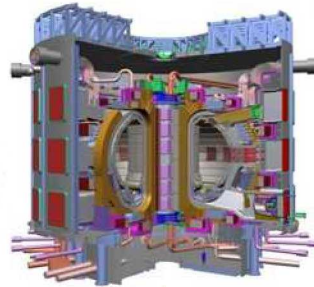
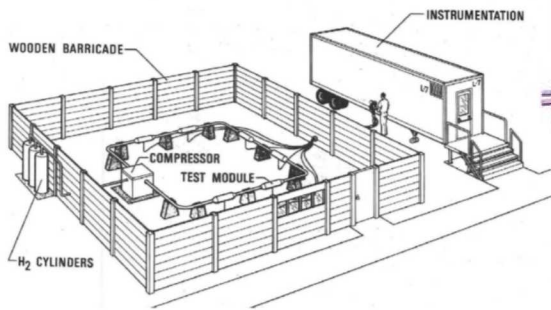

### FUSION ENERGY SCIENCES

### Conference Organization

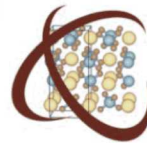

### METAL HYDRIDE CENTER OF EXCELLENCE

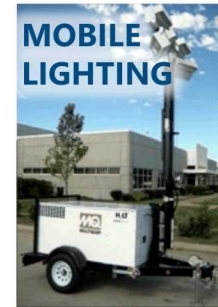

### Lift-Truck Lifecycle Requirements



1960

1970

1980

1990

2000

2005

2010

2015

2020



### METALLURGY

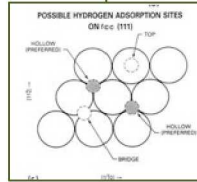

### Embedded Atom Method



### RATLER



### AUTOMOTIVE STORAGE

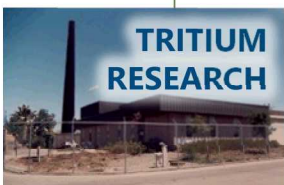

### TRITIUM RESEARCH

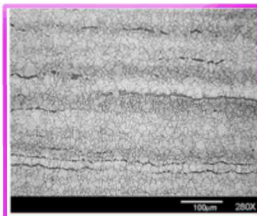

### MINING LOCOMOTIVE

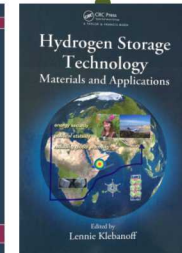
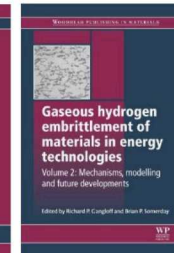
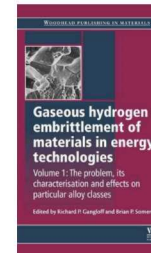

### 3 Sandia Brings Value through Research in Materials and Safety

Sandia provides deep, quantitative understanding and a scientific basis for...

**Materials** – methods for discovery and evaluating their properties and performance for hydrogen production, storage and utilization

**Safety** – innovations in risk analysis and the creation of risk-informed standards

We build on our science and engineering R&D to develop materials, technologies and approaches that define, optimize and enlarge hydrogen & fuel cell application space.

#### Hydrogen Production from Renewables



Develop advanced water-splitting materials and technologies for large-scale, renewable production of hydrogen

#### Hydrogen Storage Materials and Solutions

Discovering the physics that governs the behavior and limits the performance of solid storage materials

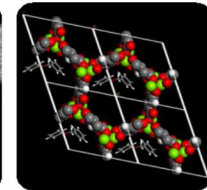
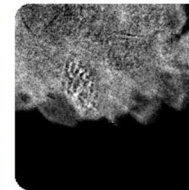

#### Hydrogen -Materials Compatibility

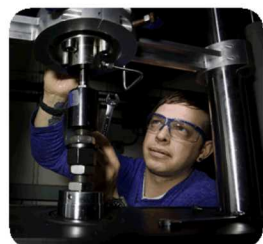

Low-cost, hydrogen-compatible materials and the science basis for their qualification



#### Fuel Cells

Membrane systems for enhanced electrochemical performance

#### Hydrogen Fueling Infrastructure

#### Technologies for Non-Vehicle Applications

Marine and rail applications. Grid integration and incorporation of renewable energy sources

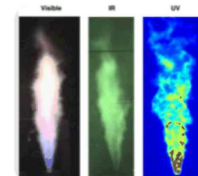

LH<sub>2</sub> release behavior and quantitative risk assessment to define the safety envelope for storage & delivery

# 4 Developing the Technical Basis for Safety, Codes & Standards (SCS)

➤ Sandia works to eliminate barriers to deployment of hydrogen fuel cell technologies through scientific leadership in the development of codes and standards.

## Hydrogen-Materials Compatibility

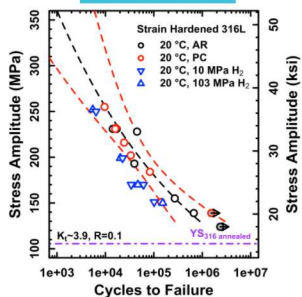

**Understand material behavior**

to predict component performance and life in operational environments

## Hydrogen Behavior

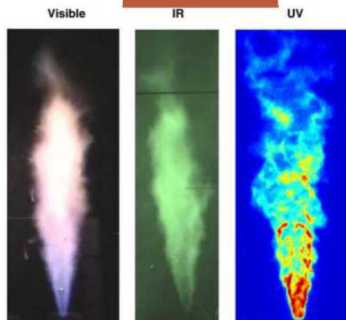
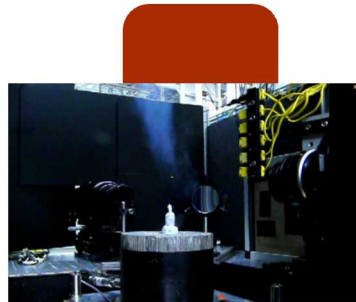

**Develop and validate scientific models**

to accurately predict hazards and harm from liquid releases, flames, etc.

## Quantitative Risk Assessment

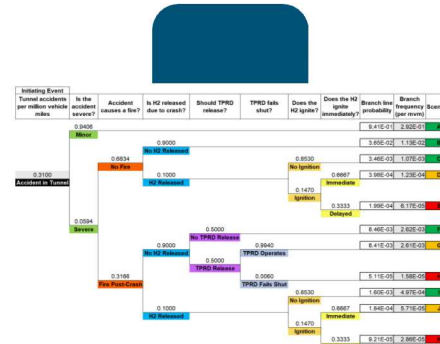

Specific Component Type	Severity	Frequency/Units	Leak Size Description
Piping			
Pipe Diameter (d) < 50 mm	Rupture	1.00E-06 Per Meter Year	100% cross sectional area
d < 50 mm	Major	5.00E-06 Per Meter Year	1" (25 mm)
50 mm ≤ d < 149 mm	Rupture	5.00E-07 Per Meter Year	100% cross sectional area
50 mm ≤ d < 149 mm	Medium	2.00E-06 Per Meter Year	1" (25 mm)
150 mm ≤ d < 299 mm	Rupture	2.00E-07 Per Meter Year	100% cross sectional area
150 mm ≤ d < 299 mm	Major	4.00E-07 Per Meter Year	1/3 of pipe diameter
150 mm ≤ d < 299 mm	Minor	7.00E-07 Per Meter Year	1" (25 mm)
300 mm ≤ d < 499 mm	Rupture	7.00E-08 Per Meter Year	100% cross sectional area
300 mm ≤ d < 499 mm	Major	2.00E-07 Per Meter Year	1/3 of pipe diameter
300 mm ≤ d < 499 mm	Medium	4.00E-07 Per Meter Year	2" (50 mm)
300 mm ≤ d < 499 mm	Minor	5.00E-07 Per Meter Year	1" (25 mm)
500 mm ≤ d < 1000 mm	Rupture	2.00E-08 Per Meter Year	100% cross sectional area
500 mm ≤ d < 1000 mm	Major	1.00E-07 Per Meter Year	1/3 of pipe diameter
500 mm ≤ d < 1000 mm	Minor	2.00E-07 Per Meter Year	2" (50 mm)
500 mm ≤ d < 1000 mm	Very Small	4.00E-07 Per Meter Year	1" (25 mm)

**Apply quantitative risk assessment techniques**

in real hydrogen infrastructure and emerging technology

## Integration

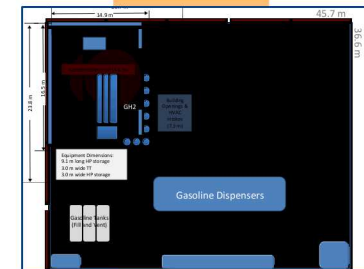
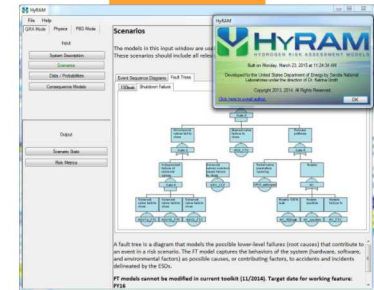

**Develop integrated methods and algorithms**

for enabling consistent, logical and defensible QRA

## Hydrogen Effects on Materials Laboratory

This lab is a core capability for the U.S. Department of Energy (DOE) and houses specialized equipment for evaluating materials in high-pressure gaseous hydrogen.

- Fracture and fatigue testing in high-pressure (up to 140 MPa/20ksi) gaseous hydrogen
- High-pressure testing at controlled (constant) temperature (from 220K to 450K)
- Constant-displacement, environmentally-assisted (up to 200 MPa/29 ksi gas pressure temperatures from 200K to 440K) crack growth testing
- Thermal precharging (at high-pressure and elevated temperature (up to 573K) to produce controlled hydrogen content within the specimens prior to evaluation.
- Pressure cycling of metals and non-metals in controlled pressures (up to 100 MPa/14.5 ksi) and temperature (from 220K and 400K).

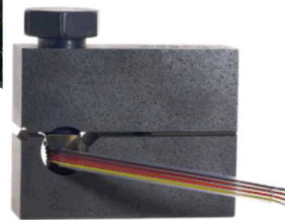

## 6 Additional Capabilities for Hydrogen and Materials Research

### Hydrogen Transport and Trapping

**Laboratory:** Instruments for measuring transport (or diffusion) of hydrogen in and through materials

### Hydrogen Surface-Interactions

**Laboratory:** Capabilities for measuring adsorption and desorption of hydrogen at a material's surface

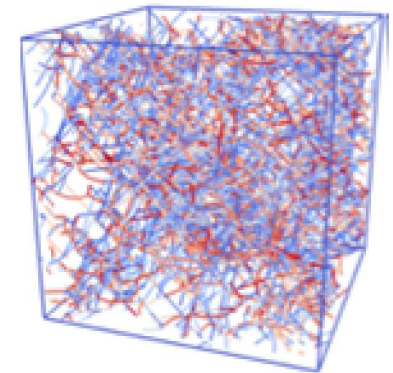
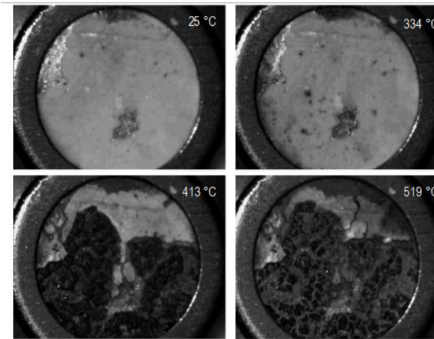
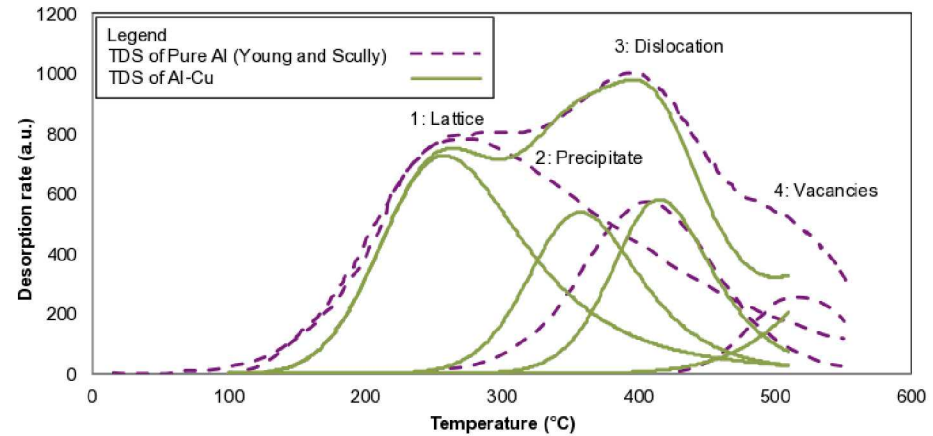
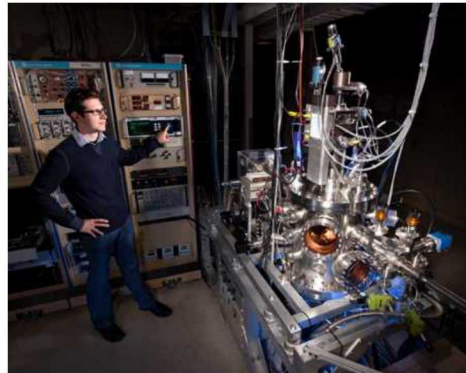

**Computational Materials Science:** Atomic-through-continuum models for studying the mechanisms of hydrogen-assisted fatigue and fracture, diffusion and transport of hydrogen within materials, and the evolution of microstructural features that can trap hydrogen (e.g. dislocations, grain boundaries).

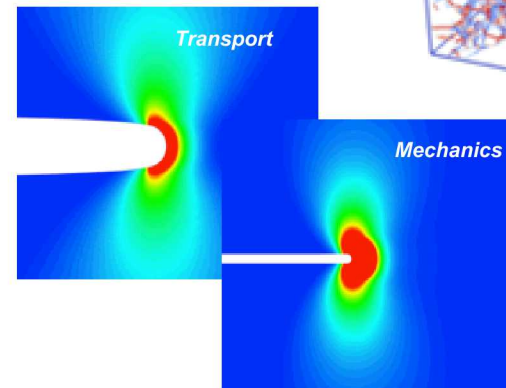

## 7 Recent Advances in Safety, Codes and Standards

- Improved **SAE J2579 Appendix B** by providing data and information to guide materials selection not directly found in past versions of the code .
- Developed **Code Case 2938** for **ASME B&PV Code**, which puts forth a “master design curve” that captures fatigue crack growth behavior for common pressure vessel and pipeline steels in high-pressure gaseous hydrogen, in lieu of difficult-to-perform measurements.
- Developed risk criteria to justify reduced gaseous hydrogen separation distances approved by committee for inclusion in 2020 revisions of **NFPA 2/55**.
- Expanded our Hydrogen Risk Assessment Model (HyRAM) software’s flexibility to a variety of applications by enabling users to edit the existing fault tree.
- Conducted measurements of ignited hydrogen properties at cryogenic temperatures to provide data-informed models of liquid hydrogen releases.

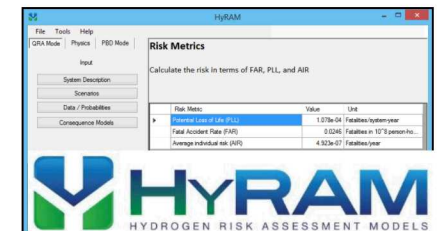
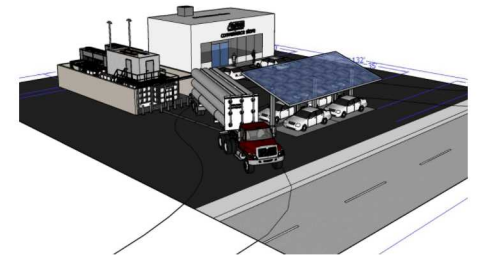
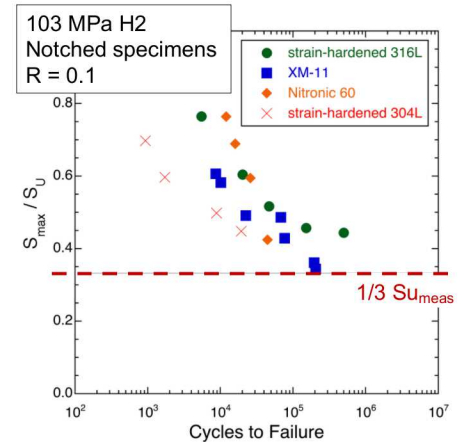
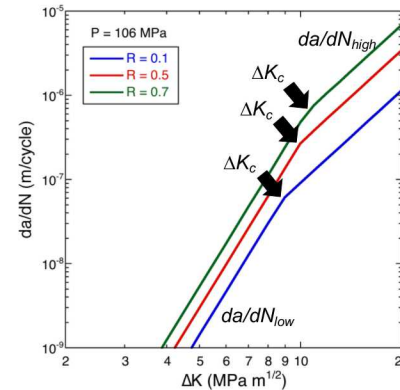

## Diagnostics for Large-Scale Releases

- Standards committees needs validation of our physical models on large-scale gaseous and liquid hydrogen releases. Existing data/videos on such releases are not quantitative.
- Developing diagnostic to measure quantitative characteristics (i.e. temperature, velocity, concentration) of large-scale releases under realistic environmental conditions (e.g. wind).

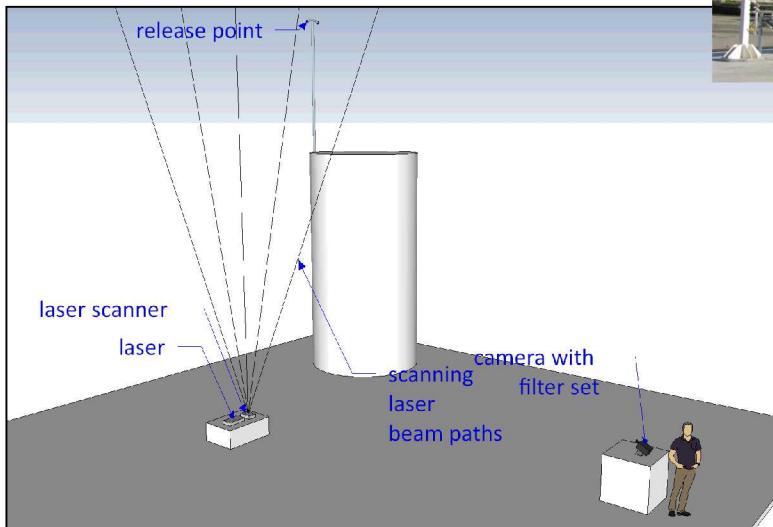
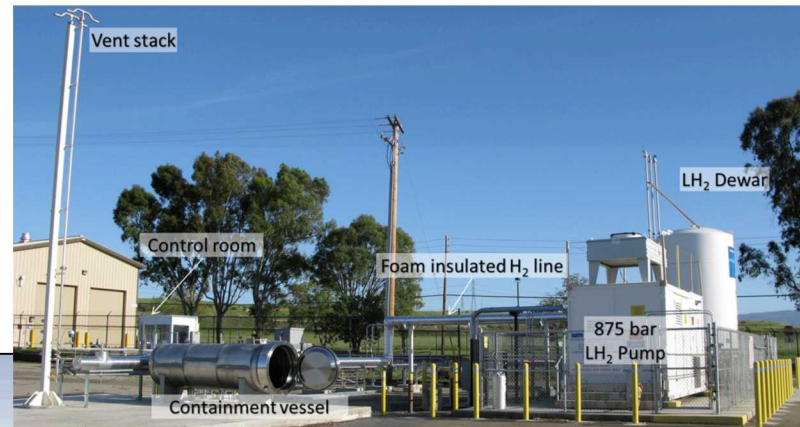
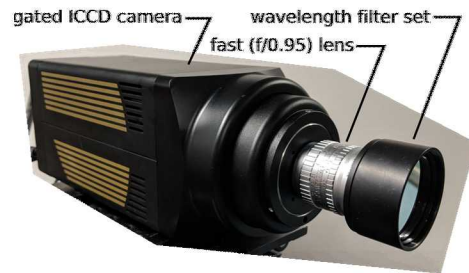

# 9 Tunnel Safety for Urban Use of Fuel Cell Electric Vehicles

- Success of FCEVs requires assessing whether hydrogen vehicle use in tunnels presents challenges that differ from other fuels.
- Addressing tunnels collaboratively with DOT to facilitate FCEV use elsewhere in the US
  - Creation of a DOE/DOT-FHA collaboration on alternative fuels use in tunnels
  - Initiated IPHE RCSS tunnel safety workshop to obtain community-wide consideration of issues
  - Completed journal article on risk assessment of FCEVs in tunnels, accepted for publication

## Scenario of concern for Boston AHJ: overturned vehicle with TPRD pointed toward tunnel ceiling

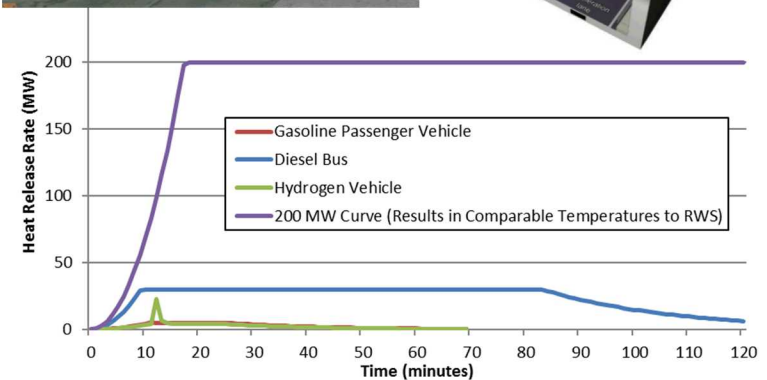
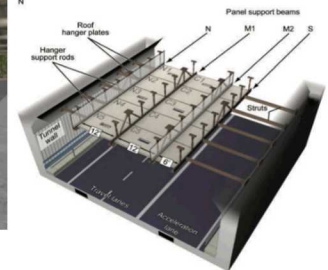
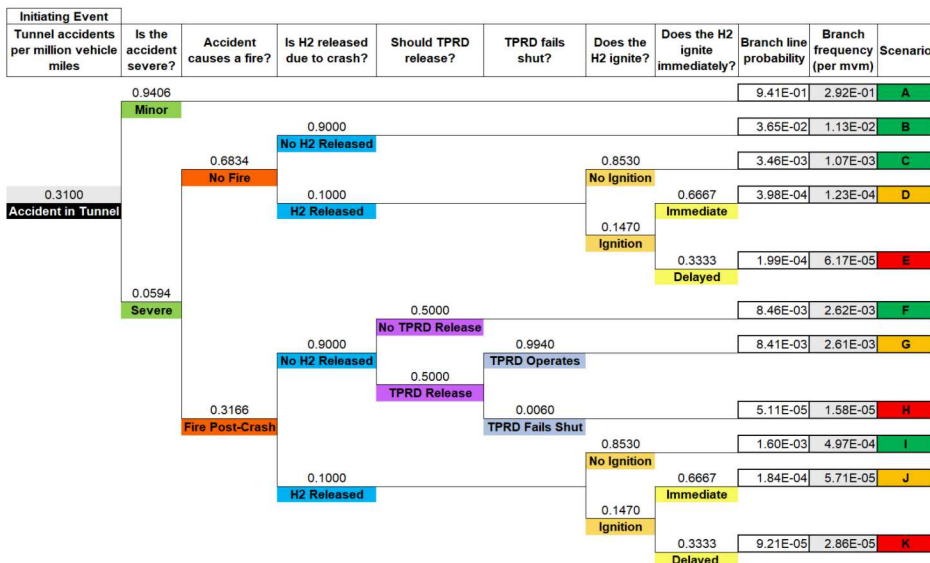

**FCEV releases less energy than a typical Heavy Goods Vehicle fire**

# Hydrogen Fueling Infrastructure Research and Station Technology (H2FIRST)

➤ Goal: Address challenges/obstacles to hydrogen fueling station deployment.

**H2FIRST** **H2USA**

**H2FIRST Reference Station Design Task**

**Project Deliverable 2-2**

Joseph Pratt  
Sandia National Laboratories

Danny Terlip, Chris Ainscough, Jennifer Kurtz  
National Renewable Energy Laboratory

Amgad Elgowainy  
Argonne National Laboratory

**H2FIRST** **H2USA**

**Comparison of conventional vs. modular hydrogen refueling stations, and on-site production vs. delivery**

Ethan S. Hecht, Joseph Pratt  
Sandia National Laboratories

**Hydrogen Reference Stations for Urban Sites**

Brian Ehrhart  
Gabriela Brani-Anleu, Ethan Hecht, Chris LaFleur, Alice Muna, Ethan Sena, Carl Rivkin (NREL), Joe Pratt

Building off of previous reference design projects to increase station capacity, reduce footprint and improve station details

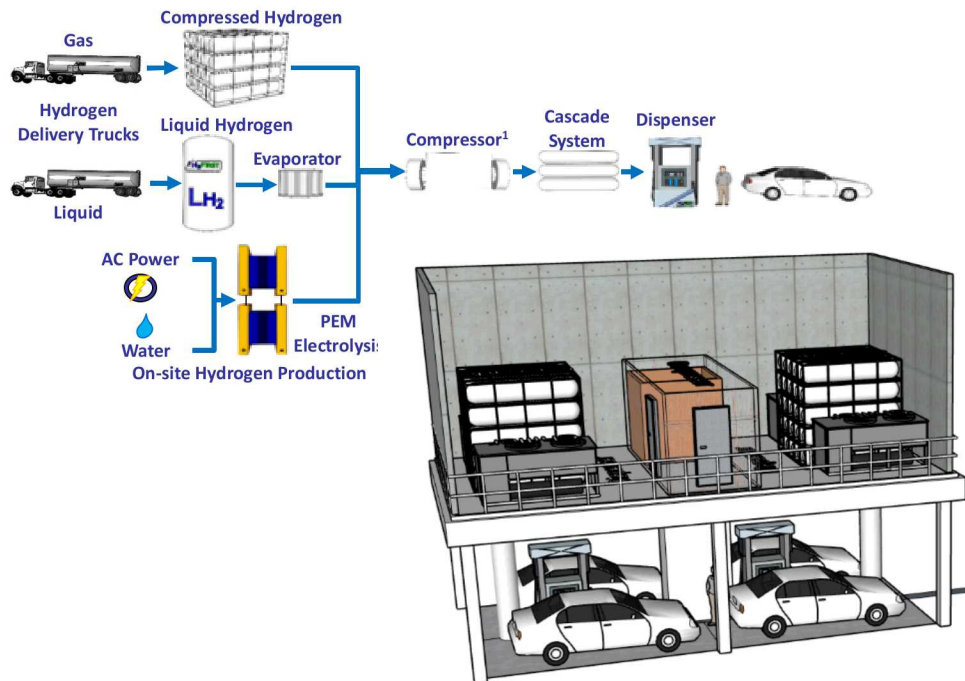

	Total Lot Area (ft <sup>2</sup> )	Reduction from Base Case
Base Case Gas	17,640	--
New NFPA Separation Distances	16,240	7.9%
New Delivery Single Truck	14,500	17.8%
New Delivery Double Truck	15,875	10.0%
Gasoline Co-Location	21,000	-19.0% (Increase)
Underground Direct-Bury	15,400	12.7%
Underground Vault	13,720	22.2%
Rooftop Storage	16,000	9.3 %

	Total Lot Area (ft <sup>2</sup> )	Reduction from Base Case
Base Case Liquid	21,250	--
New NFPA Separation Distances	18,252	14.1%
New Liquid Delivery	17,400	18.1%
Gasoline Co-Location	22,040	-3.7% (Increase)
Underground Direct-Bury	15,515	27.0%
Rooftop Storage	19,840	6.63 %

# Solar Thermo-Chemical Hydrogen Production (STCH)

- Clean and sustainable hydrogen production at large-scale is needed to realize emissions reductions over SMR.
- Solar heat can be used to thermo-chemically induce water-splitting in specific materials.
  - MW scale concentrated solar power (CSP) provides heat for metal oxide reduction.
  - Oxidation of reduced metals via contact with steam produces hydrogen.

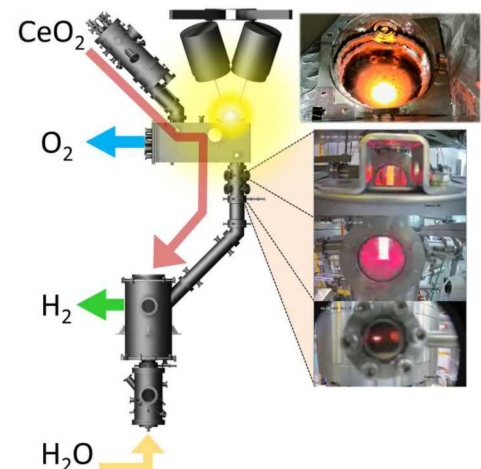
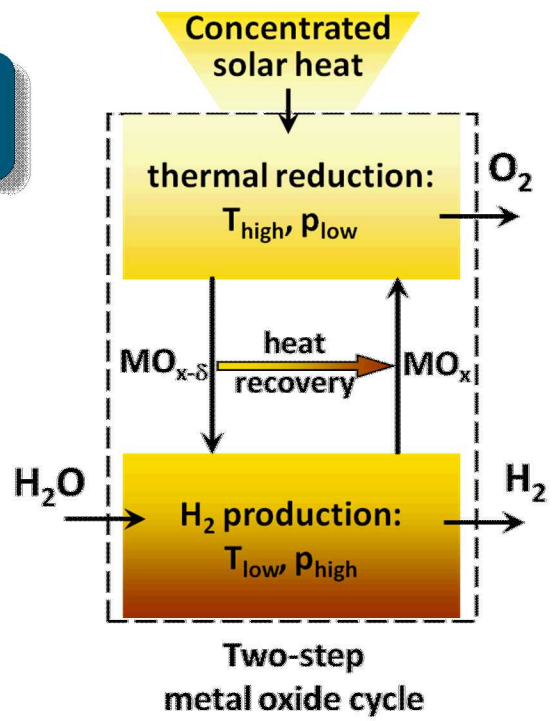
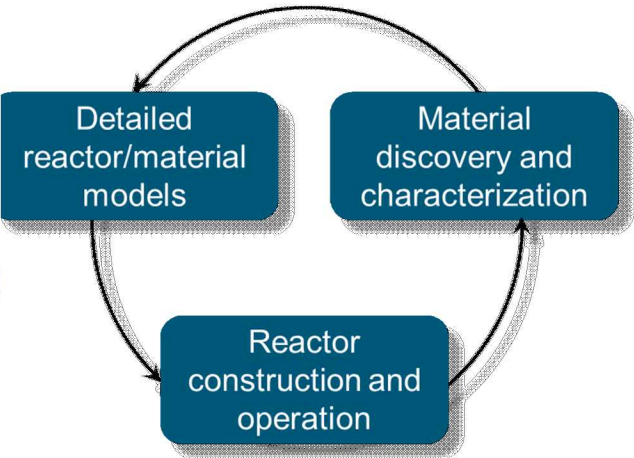
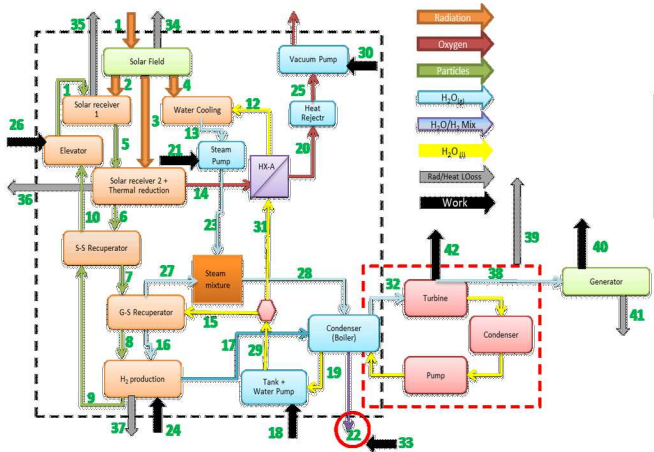

CPR<sup>2</sup> technology produced 2 liters of hydrogen on simulated sun.

# Hydrogen Fuel Cell Mobile Light Tower



# Hydrogen Fuel Cell Generator for Maritime/Ports



# Zero Emission Maritime Vessels



# Feasibility of Hydrogen Fuel Cell-Powered Maritime Vessels



- The question was brought to Sandia as to whether hydrogen powered marine vessels are feasible considering technical, economic and regulatory factors.
- SF-BREEZE high-speed passenger ferry
  - Catamaran design has similar capacity to existing ferry service.
  - Analysis shows modest emissions reduction with SMR-produced hydrogen, zero emission with renewable hydrogen.

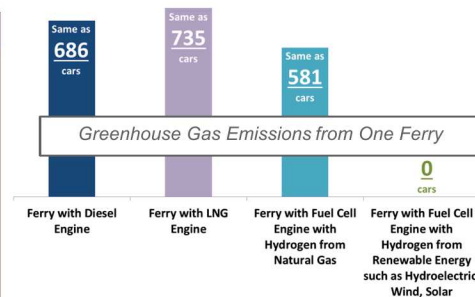
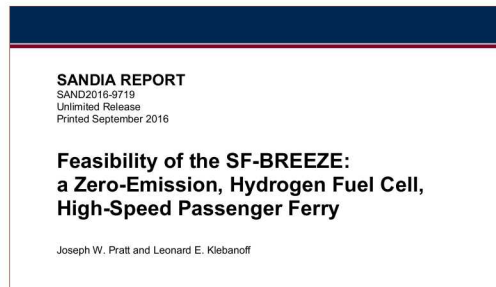
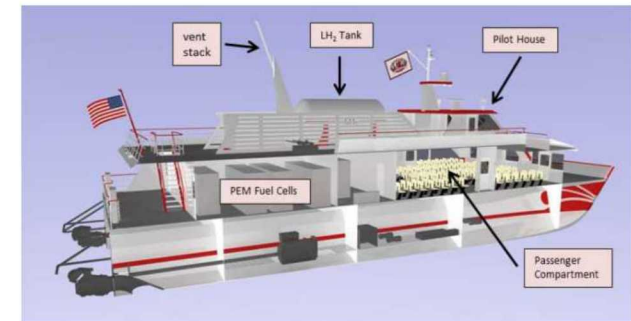

- Zero-V coastal research vessel
  - Motivation from Scripps Institution of Oceanography to design a research vessel with zero-emissions and noise
  - Feasibility was found for a vessel able to perform 14 Scripps science missions with a 2,400 nautical mile range.

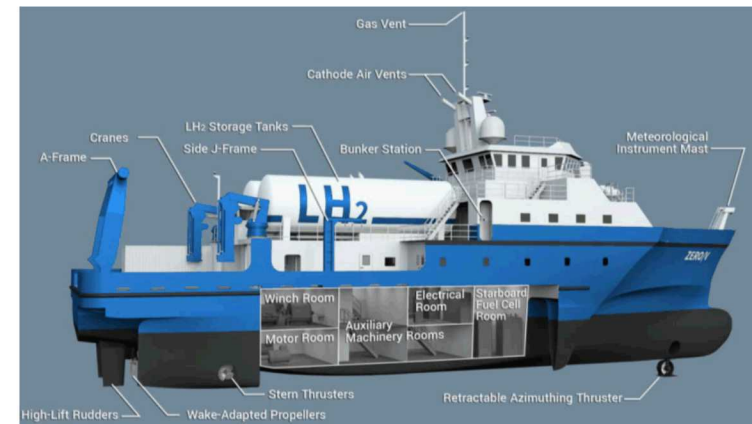

# Assessing the Impact of Hydrogen for Rail (H<sub>2</sub>@Rail)

- Use of hydrogen for rail applications is thought to have the potential to significantly increase hydrogen demand and thereby, through economies-of-scale, reduce the overall cost of hydrogen technologies.
- Sandia is developing a methodology to evaluate and verify this potential impact.

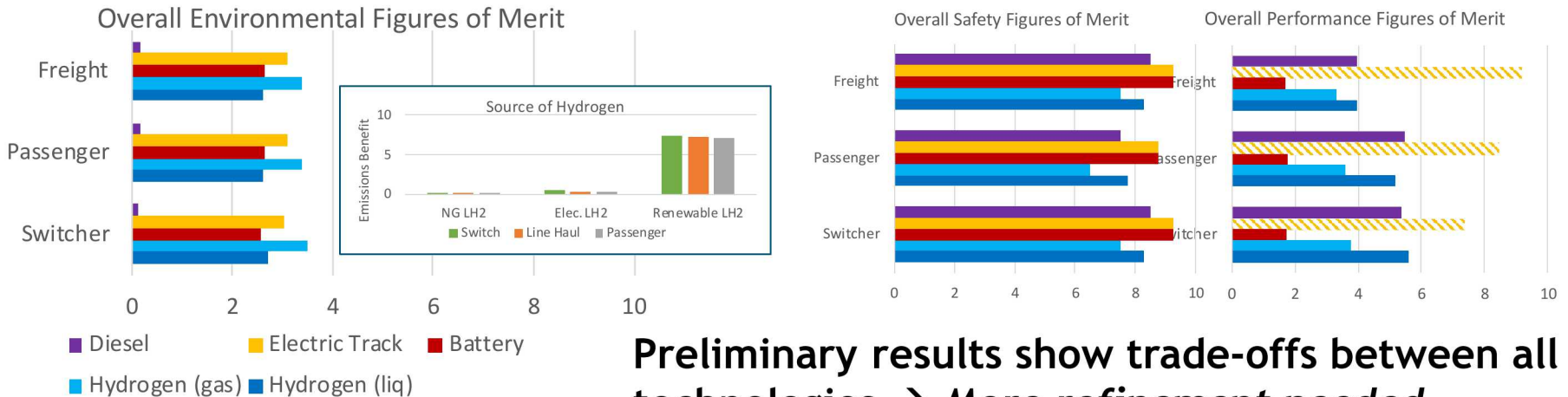
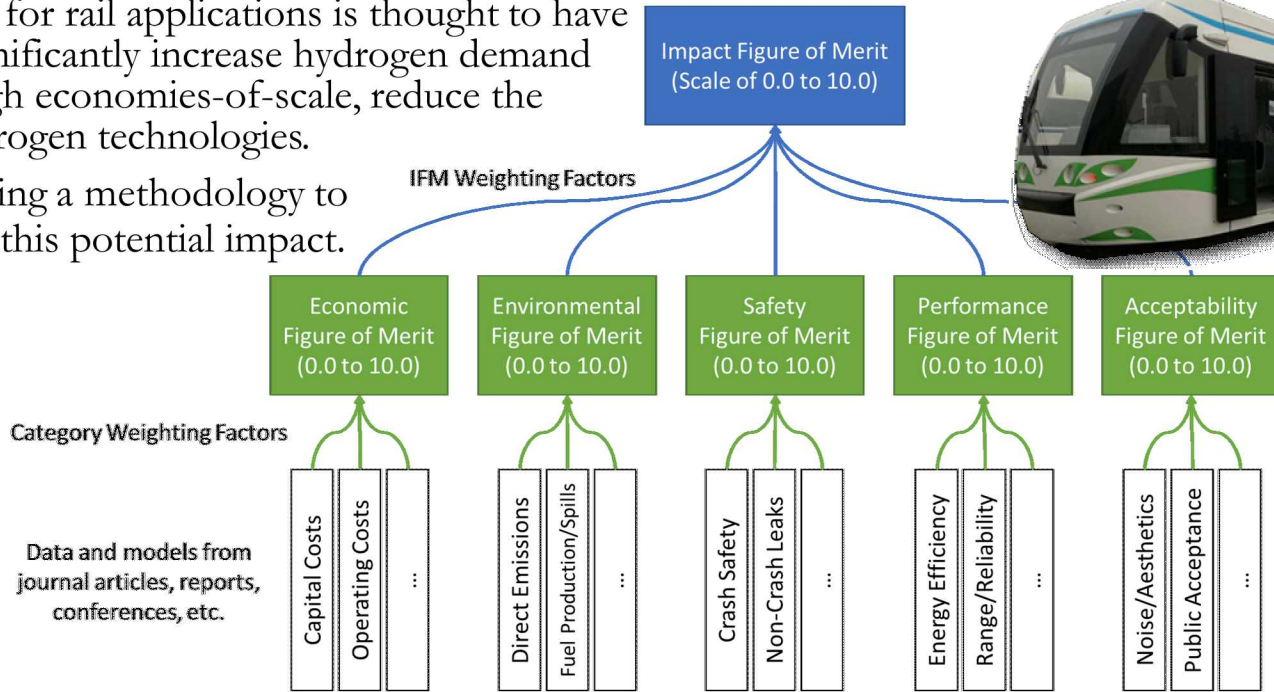

**Preliminary results show trade-offs between all technologies → More refinement needed**

# Advances in Materials for Hydrogen Fuel Cell Technologies

- Sandia supports FCTO's goal of improving the performance, enhancing the reliability and reducing the cost of hydrogen **production**, **storage** and **utilization** through the development of advanced materials achieved through foundational scientific understanding.

## ➤ Nano-structuring for hydrogen storage materials

- Investigation of nanoscale metal hydrides reveals weight & volume capacity increases without generation of inefficient intermediate phases during hydrogenation.

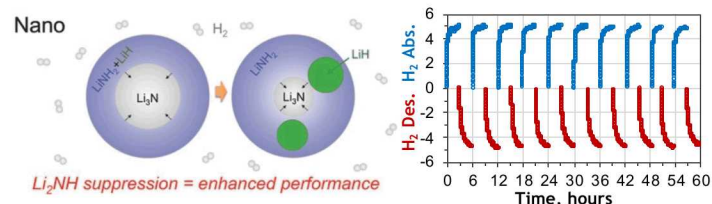

## ➤ Alternative microstructures improve fracture toughness of storage tank steels

- Identifying microstructure features needed to ensure optimal properties (high strength and high fracture toughness) and component performance

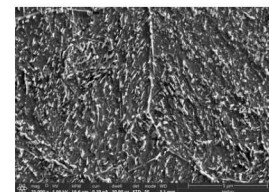
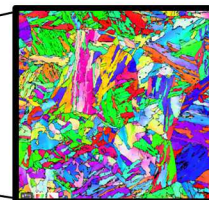

## ➤ Formulating new materials for solar thermochemical hydrogen production

- BaCe<sub>0.25</sub>Mn<sub>0.75</sub>O<sub>3</sub> (BCM) yields nearly 3X more hydrogen than conventional compounds.

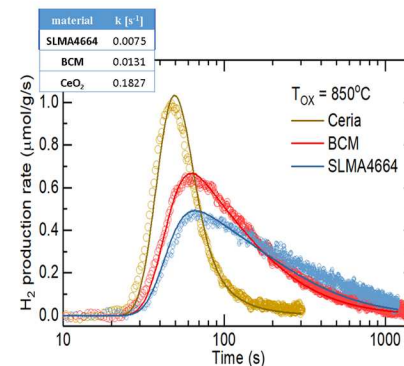
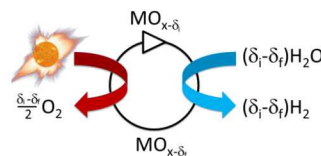

# H-Mat: Science-Based Advancement of Materials for Hydrogen Technologies

- Elucidate the mechanisms of hydrogen-materials interactions to inform **science-based strategies to design the microstructure** of metals with improved resistance to hydrogen degradation

## Tasks include:

- High-strength ferritic steel microstructures
- High-strength aluminum alloys
- Transferability of damage and crack nucleation
- Microstructure of austenitic stainless steels
- Materials for cryogenic hydrogen service
- Mechanisms of polymer degradation
- Multiscale modeling of polymer materials
- Hydrogen-resistant polymeric formulations

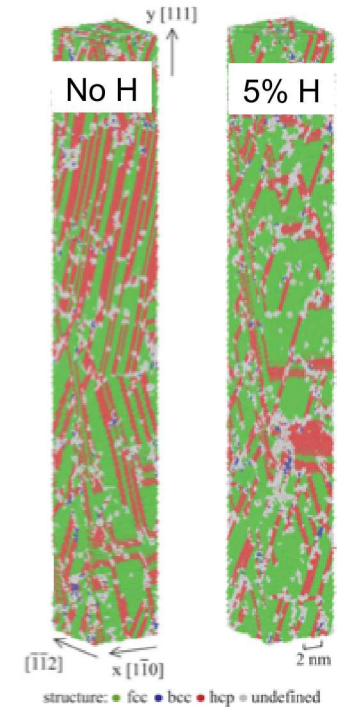
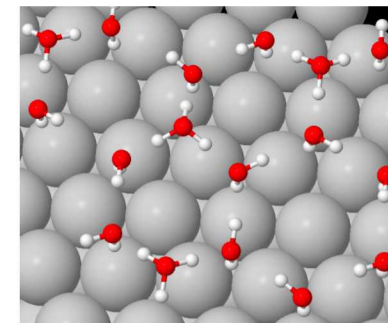
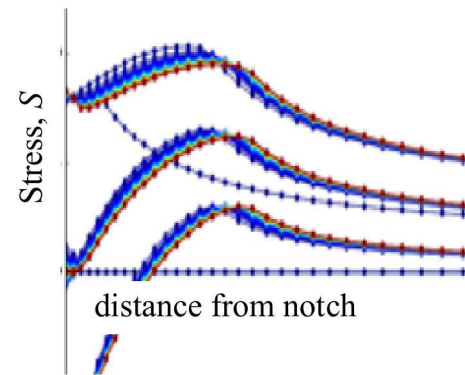
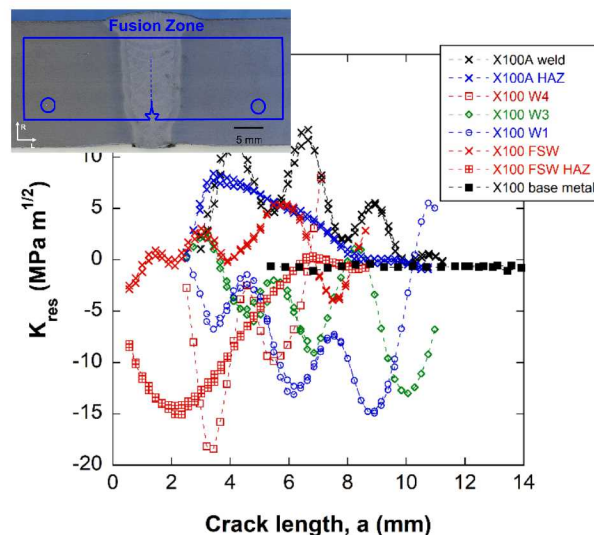
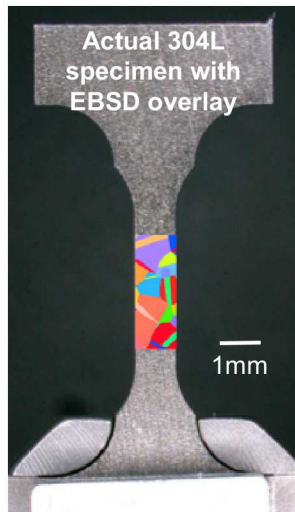

Hydrogen  
Materials  
Compatibility  
Consortium



<https://www.energy.gov/eere/fuelcells/h-mat-hydrogen-materials-consortium>



- HydroGEN combines more than 80 unique, world-class capabilities (nodes) to foster cross-cutting innovation in materials to advance all emerging water-splitting pathways for hydrogen production.

## Materials Theory/Computation

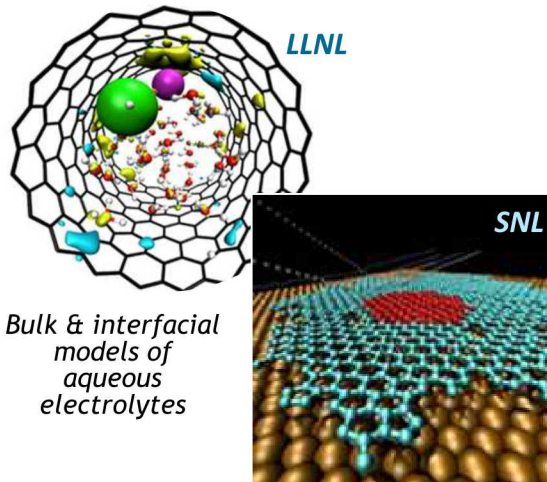

LAMMPS classic molecular dynamics modeling relevant to H<sub>2</sub>O splitting

## Advanced Materials Synthesis

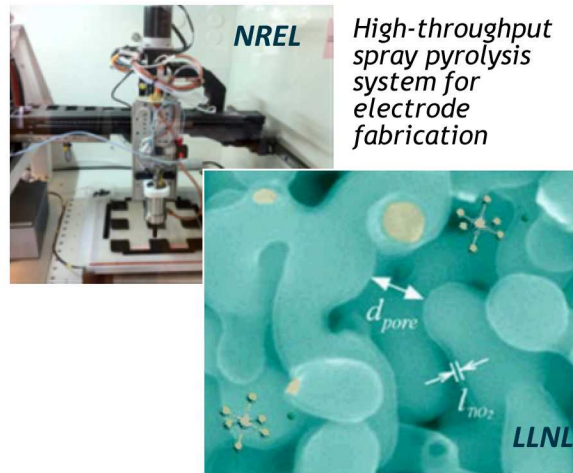

Conformal ultrathin TiO<sub>2</sub> ALD coating on bulk nanoporous gold

## Characterization & Analytics

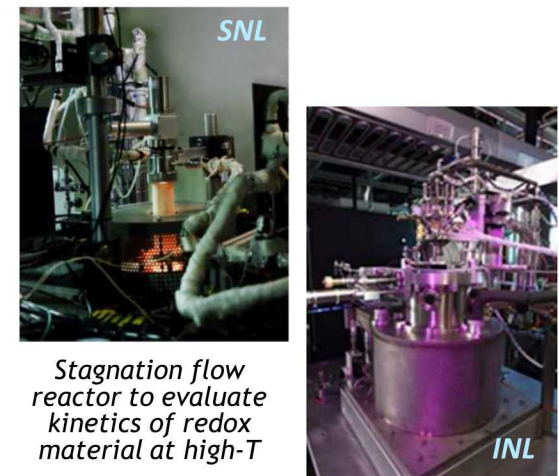

TAP reactor for extracting quantitative kinetic data

# HyMARC: Advanced Materials for Hydrogen Storage

➤ The Hydrogen Materials Advanced Research Consortium (HyMARC) enables the discovery of new hydrogen storage materials, hybrid material systems, and (chemical) hydrogen carriers.

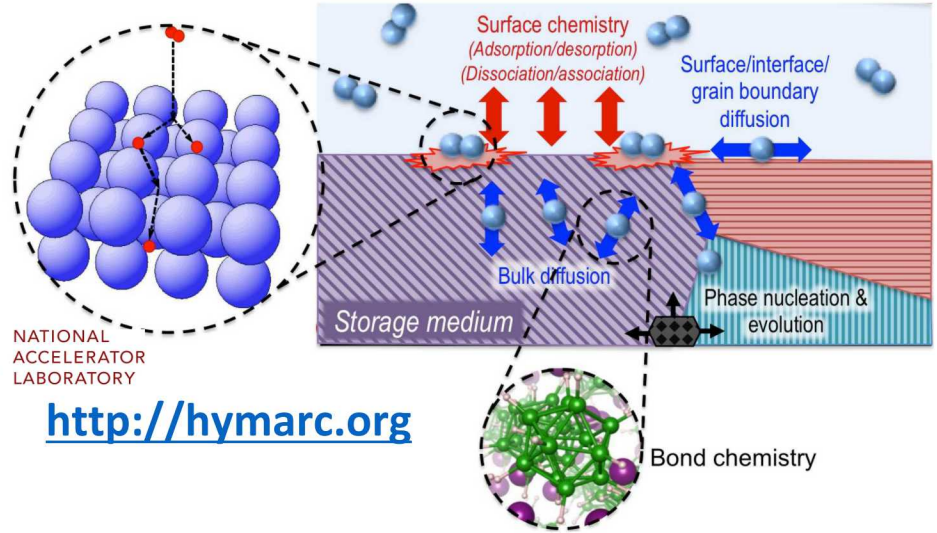

<http://hymarc.org>

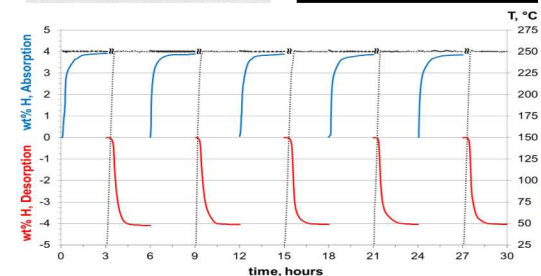
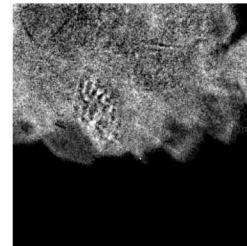
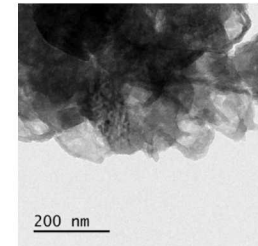
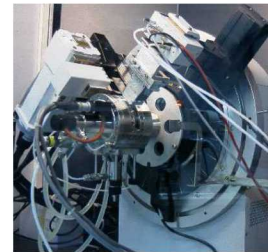
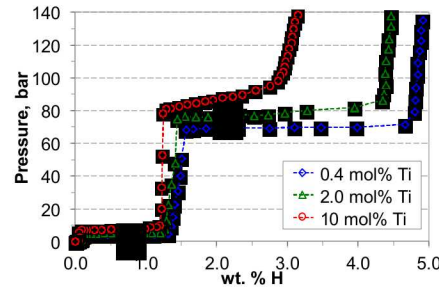
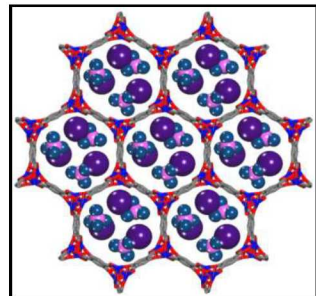
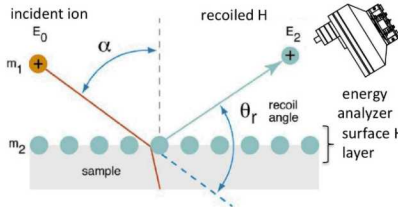
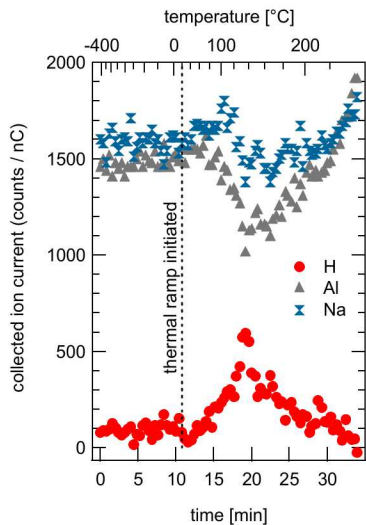

# Customers and Partners



## Energy Efficiency & Renewable Energy



## Hawaii Hydrogen Carriers, LLC



# H<sub>2</sub>@Scale: Hydrogen as an Energy Carrier to Enable...

