

This material is based upon work supported by the Department of Homeland Security Science and Technology Directorate under contract No. HSHQPM-17-X-00141. Any opinions, findings, conclusions or recommendations expressed in this material are those of the author(s) and do not necessarily reflect the views of the Department of Homeland Security.

This paper describes objective technical results and analysis. Any subjective views or opinions that might be expressed in the paper do not necessarily represent the views of the U.S. Department of Energy or the United States Government.

SAND2019-5909C

# Open Threat Assessment Platform Modular AIT Stream-of-Commerce

**TSA Program Managers:** Chris Schooler, Ron Molway, Doug MacIvor

**S&T Program Manager:** John Fortune

**Sandia Project Leads:** Andrew Cox, John Parmeter

**Sandia Partners:** Stratovan, Amir Neeman Consulting, PNNL, IDSS, Analogic, Rapiscan, Telesecurity, Csup2, ALERT, Synapse, MITLL, Capture, Booz Allen Hamilton



Transportation  
Security  
Administration

Sandia National Laboratories is a multi-program laboratory managed and operated by Sandia Corporation, a wholly owned subsidiary of Lockheed Martin Corporation, for the U.S. Department of Energy's National Nuclear Security Administration under contract DE-AC04-94AL85000. SAND NO. 2011-XXXXP

Sandia National Laboratories is a multimission laboratory managed and operated by National Technology & Engineering Solutions of Sandia, LLC, a wholly owned subsidiary of Honeywell International Inc., for the U.S. Department of Energy's National Nuclear Security Administration under contract DE-NA0003525.

## TSA Strategic Goal 2.2: Reduce the time to field solutions

**2.2.1** Establish strategies that embrace *agile acquisition methods* in order to support **rapid prototyping, incremental development, and cycles of continuous improvement.**

**2.2.2** Develop an integrated countermeasures architecture...integrating countermeasure platforms to enable data fusion and new networked security capabilities

**2.2.3** *Modularize transportation security equipment to **disaggregate sensors from data analytics**, and to improve equipment **upgradeability and interoperability**...Broaden TSA's ability to **incorporate innovations from non-traditional vendors**...*

--Transportation Security Administration / Administrator's Intent

# Solution: Modularity Increases the Market for Innovations & Increases the CONOPs Options.

Modularity is the ability of systems to be “plug-and-play” with different add-on capabilities such as new threat detection algorithms or GUIs (among many others).

Modularity also has the potential to

- i. Lower barriers to entry for new vendors
- ii. Introduce new capabilities into the field at a quicker pace
- iii. Allow TSA to reconfigure screening workflows into a variety of CONOPs such as more comprehensive and individualized risk-based screening.

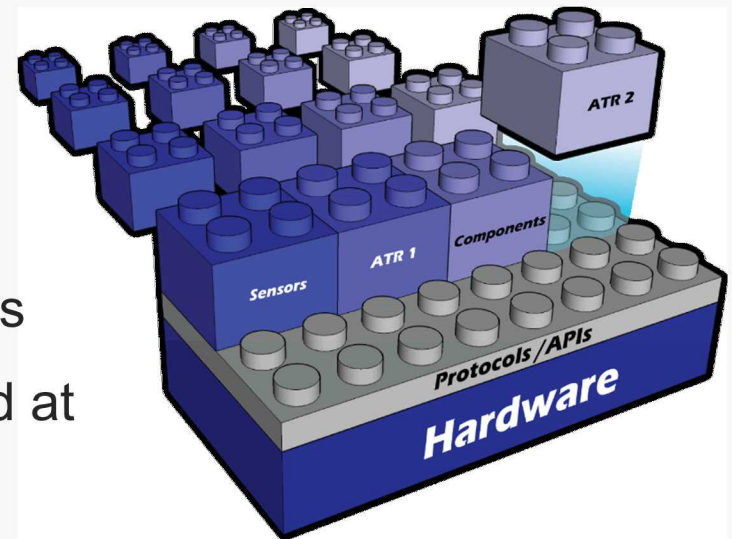

# Open Threat Assessment Platform

**OTAP fulfills TSA Strategic Objective 2.2.3: Modularity.** OTAP enables the implementation of new solutions developed by industry (OEM and 3<sup>rd</sup> parties) by creating the tools to implement an open, modular architecture for aviation security technology.

## Core OTAP Elements

### SOC (Non-Threat Data → lower Pfa)

Large database of carry-on CP-CT bag images; annotated, ground-truthed, & integrated with passenger and flight metadata.

### Tyndall (Threat Data → Higher Pd)

Database of CP-CT threat scans; annotated, ground-truthed, & enhanced with packing/clutter metadata

### Open Platform Software Library (OPSL)

Software package (SDK) of open, commonly available, and standardized data interfaces, exchanges, and formats enabling integration of 3<sup>rd</sup>-party apps

### Passenger Baggage Object Database (PBOD)

Non-Proprietary DICOS DB of CT & AT scanned outputs of potential threats, info on non-threats, & any associated metadata used to train algorithms

### ATR Algorithm Integration

Detection algorithms built independently or from PBOD data and integrated with AT, CT, or AIT platforms via OPSL

### 3rd Party Hardware Component Integration

Integration of 3rd party specialized hardware component on an OTAP-enabled system

# HD-AIT + Prize + OPSL = Modular AIT

- DHS S&T/TSA sponsored the Passenger Screening Algorithm Challenge
  - **Non-proprietary scans** distributed via the Kaggle competition site
  - Hundreds of performers, 8 winners chosen. Variety of advanced methods used.
  - Excellent ATR performance.
- Winning algorithms handed off to S&T
  - Noblis, TSL, JHU-APL, others conducted eval
- Sandia “wrapped” ATRs w/OPSL (& “containerized” for different OS)
- ATRs successfully run via OPSL
- Successful integration w/HD-AIT prototype as of last week

## Because:

- S&T collected and curated a non-proprietary scan DB
- S&T accessed a vibrant market of ATR developers via the Passenger Screening Algorithm Challenge
- OPSL allowed HD-AIT to plug in ATRs

**TSA now has the ability to continuously update and improve ATRs using the latest machine-learning methods**

# Large, Quality Datasets are Critical for ATRs

Machine/Deep Learning (ML/DL) methods can create higher performing ATRs...***but only if they have large, high-quality, ground-truthed, metadata-augmented datasets; Large, quality Datasets are the developmental chokepoint*** to deploying better ATRs for CT, AT, and AIT...Not ML skillsets.

- The ***SOC*** Data Collection Project is ***creating a comprehensive large database of carry-on CP-CT bag images*** integrated with passenger and flight metadata.
- The OTAP Tyndall data-collection effort has ***completed voxel-by-voxel annotation of 5 materials for IDSS & Analogic each: ~300 threat scans per material.***

## *SOC Key Current Activity Elements and Deliverables*

### **CP-CT Image Data**

Collect image data from all AT/CT CP-CT OEMs in multiple airports during all travel seasons to maximize diversity and scale.

***Collected 31k images.***

### **Passenger and flight data**

Integrate non-PII PAX and flight metadata (age, gender, risk score, flight origin/destination, date and time) from SecureFlight via CAT.

***Passenger-bag association process & tools.***

### **CP-CT Inspection Results**

Integrate bag alarm information, TSO decisions and other Threat Data Records (TDR) from CP-CT into SOC dbase.

***10TB comprehensive dbase and expanding.***

### **Annotation of Bag Content**

Process images using a Common Viewing Station to annotate and text-label objects and develop a database with searchable (and customizable) categories.

***Annotated 11k images***



# SOC and PBOD are Foundational *Data* Capabilities

- The **SOC** Data Collection Project is *creating a comprehensive large database of carry-on CP-CT bag images* integrated with passenger and flight metadata.
- The OTAP Tyndall data-collection effort has *completed voxel-by-voxel annotation of 5 materials for IDSS & Analogic each*: ~300 threat scans per material.

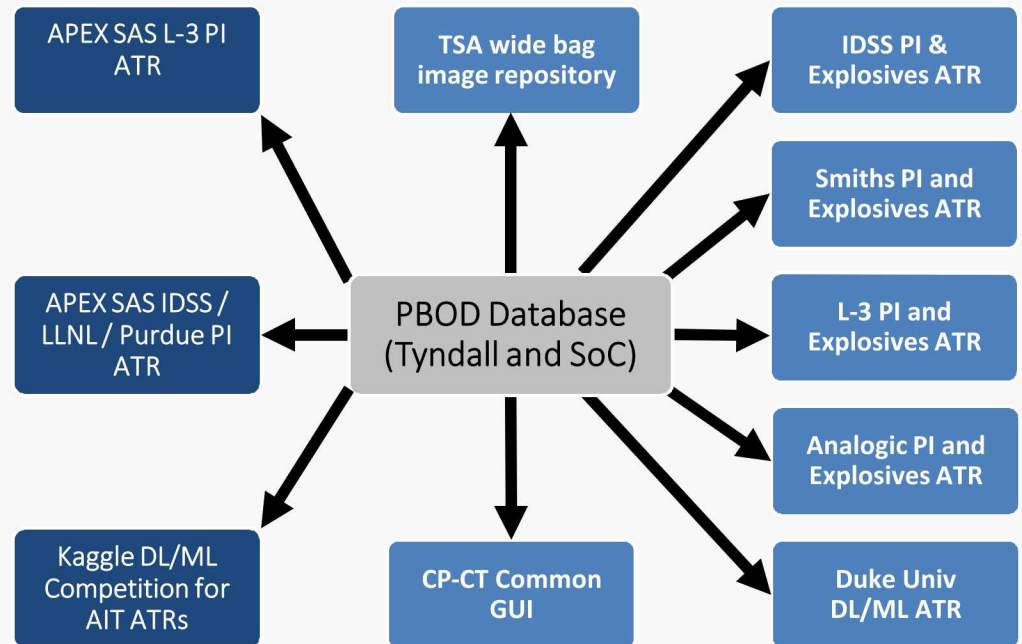

DHS S&T ML/DL Projects

TSA ML/DL Projects

***The basic foundations of a modular architecture are now available to TSA across AT, CT, and AIT.***

- OPSL 1.0 Completed, provided to OEMs and 3<sup>rd</sup>-party ATR vendors
- Database of non-proprietary threat scans and stream-of-commerce scans.
  - Tyndall: 1500 threat scans for two OEMs
  - SOC: 33k scans collected; 12k scans annotated
- Scan inventory and annotation tools.
- ATR testing tools (modifying ALERT tools).
- Demonstrations of OPSL and 3<sup>rd</sup>-party ATRs on AT, CT, and HD-AIT machines.

# Contacts

## TSA

SOC PM: Ron Molway  
[Ronald.Molway@tsa.dhs.gov](mailto:Ronald.Molway@tsa.dhs.gov)  
(202) 579-5912

OTAP PM: Chris Schooler  
[Christopher.Schooler@tsa.dhs.gov](mailto:Christopher.Schooler@tsa.dhs.gov)  
(571) 227-3621

TSA/RCA Architecture: Doug  
MacIvor  
[Douglas.Macivor@tsa.dhs.gov](mailto:Douglas.Macivor@tsa.dhs.gov)  
703-829-0209

DHS/S&T PM: John Fortune  
[john.fortune@hq.dhs.gov](mailto:john.fortune@hq.dhs.gov)  
(202) 254-6622

## Sandia

Sandia PI: Andrew Cox  
[acox@sandia.gov](mailto:acox@sandia.gov)  
925-337-1845

Sandia D-PI: John Parmeter  
[jeparme@sandia.gov](mailto:jeparme@sandia.gov)  
(505) 845-0894

# Modularity Enables More Flexible CONOPs

**Reshape TSA's mode of operation to enhance security, operational efficiency, passenger experience, and cost efficiency.**

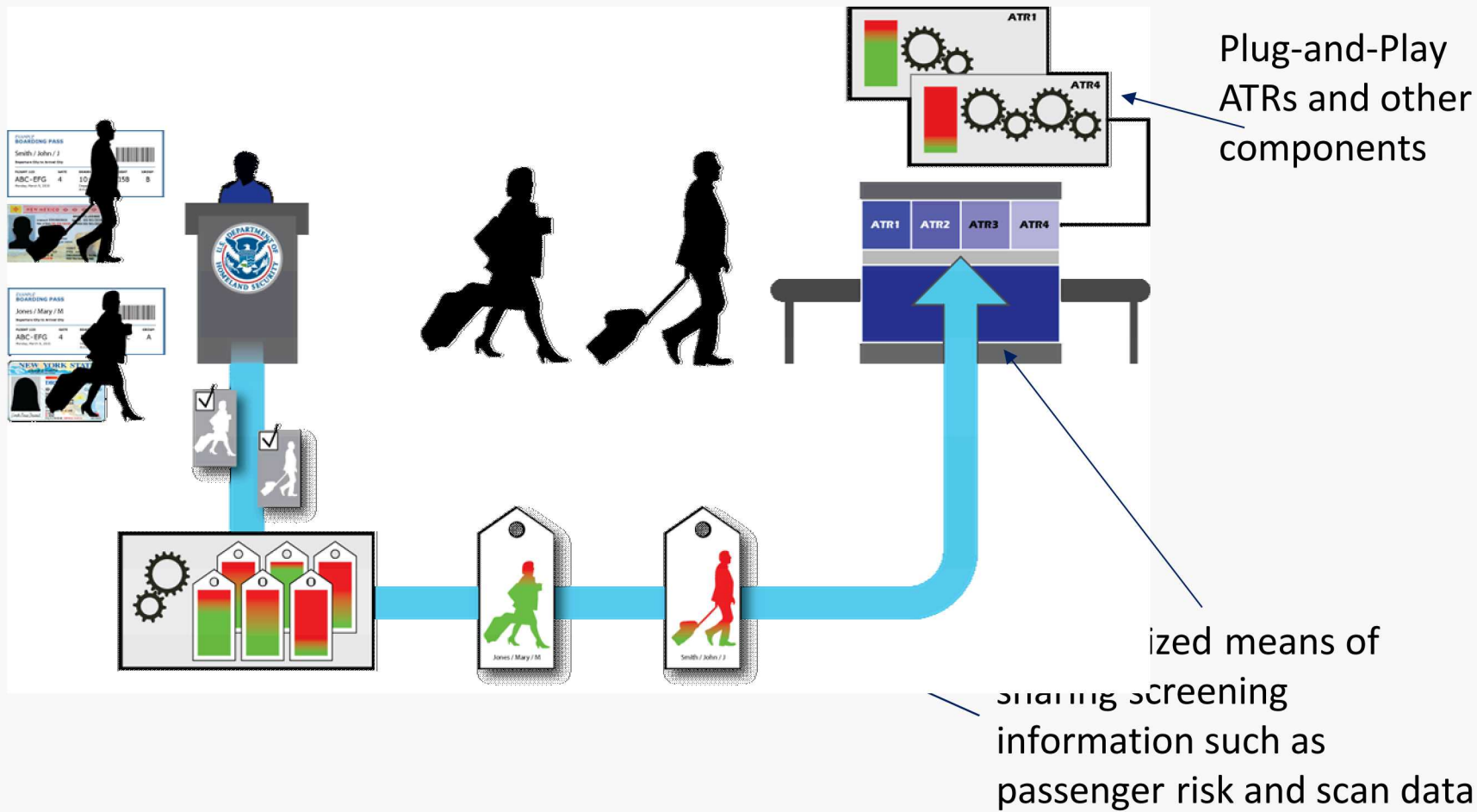

# SOC Equipment Development - SOC Camel at CAT

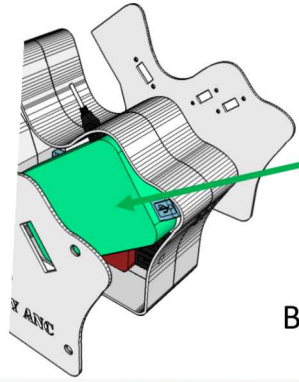

Battery



Barcode reader

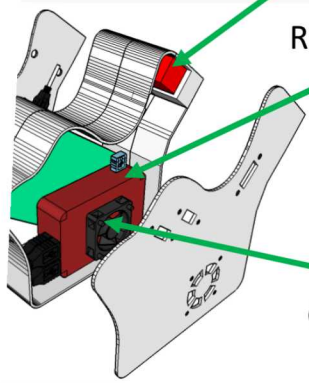

Raspberry Pi

Cooling fan



Camel on CAT

# SOC Equipment Development - SOC Chameleon at CT

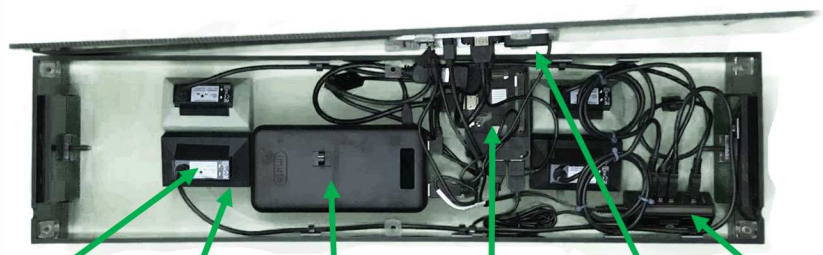

Barcode reader    Angled mount    Battery    Raspber  
y Pi    Cooling fan    USB hub

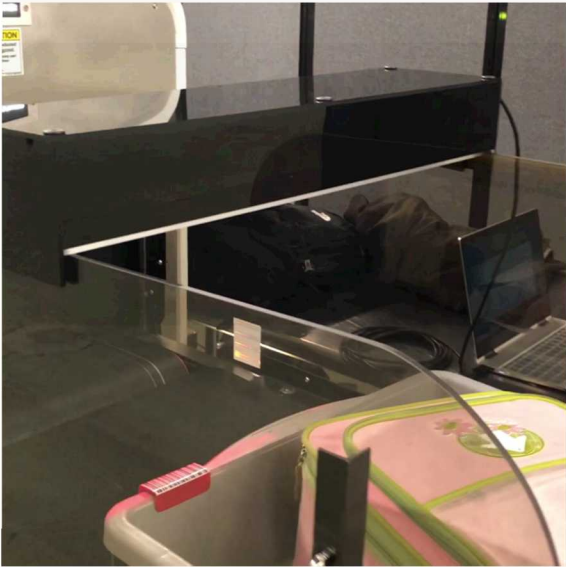
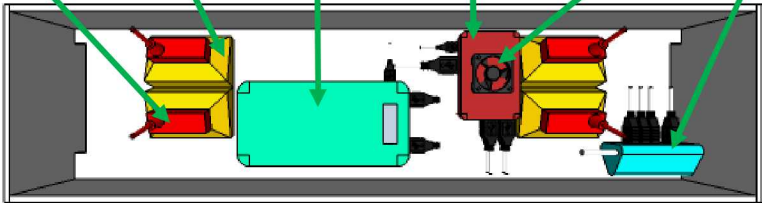

# SOC Equipment Development - SOC Lobster at CT

