

This paper describes objective technical results and analysis. Any subjective views or opinions that might be expressed in the paper do not necessarily represent the views of the U.S. Department of Energy or the United States Government.

SAND2019-5676C

Optical Diagnostics for Explosive Fragmentation and Fireballs



PRESENTED BY

Daniel Guildenbecher

Sandia National Laboratories is a multi-mission laboratory managed and operated by National Technology & Engineering Solutions of Sandia, LLC, a wholly owned subsidiary of Honeywell International Inc., for the U.S. Department of Energy's National Nuclear Security Administration under contract DE-NA0003525.

SAND2018-###

Our Mission: diagnostics from lab to full-scale

Lab scale

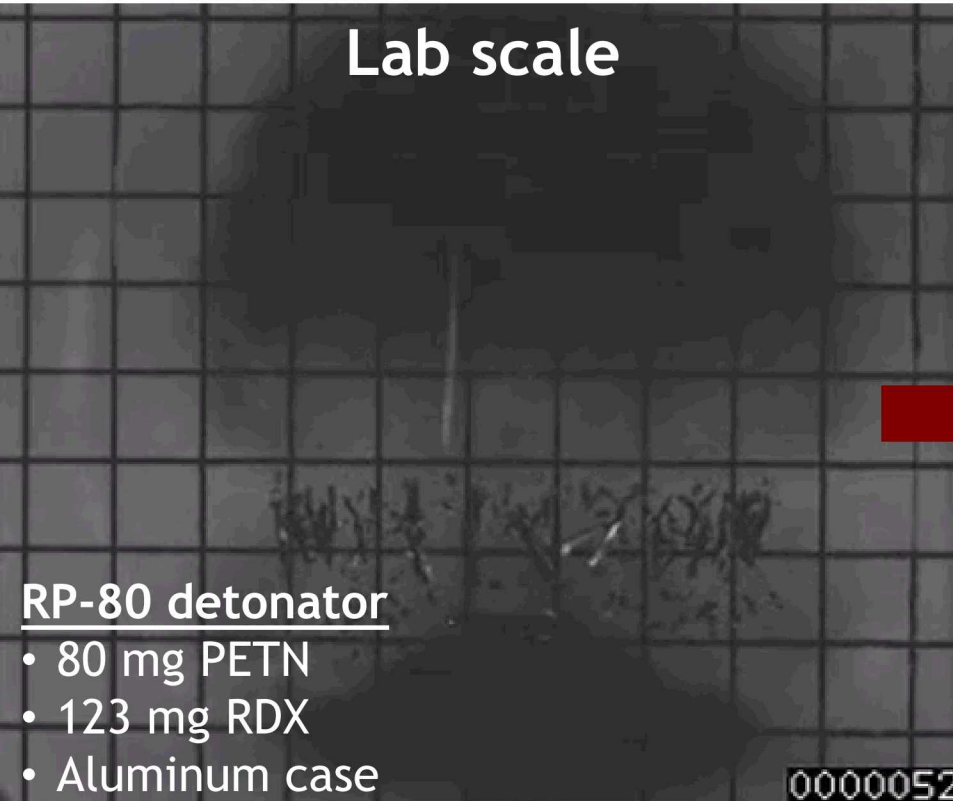

Large scale

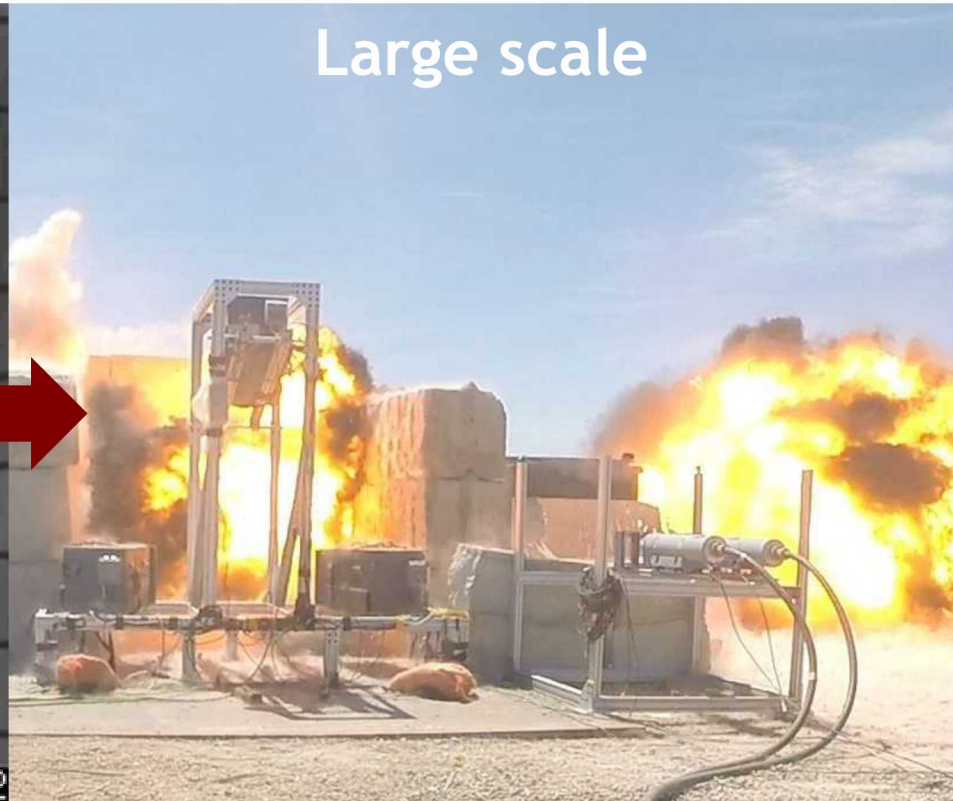

Phenomena of interest:

- Solid-phase detonation waves
- Strain and failure of metal cases
- Fragment generation and propagation
- Afterburn fireball temperature
- Soot and particulate formation
- Fireball radiative properties

Acknowledgements

The work presented here is the results of a large, creative, and productive team whose contributions are gratefully acknowledged

Post-Docs: Ellen Chen, Kate Hoffmeister, Ed DeMauro, Caroline Winters, Jonathan Retter

Students: Luke Engvall, Elise Hall, Spencer Ketchum, Michael Smyser, Anthony McMaster, Patrick Sanderson, Aaron Turbin, William Sealy, Samuel Albert, and many others....

Technologists: Thomas Grasser, Paul Farias, Marley Kunzler, Pat Ball, Lee Stauffacher, Jeff Heyborne, Rusty Spillers, John Henfling, Brian Pruett, Mike Oliver, Luke Lebow, and many others....

Collaborators: Sean Kearney, Justin Wagner, Daniel Richardson, Ben Halls, Kyle Lynch, Steve Beresh, Katya Casper, Joe Olles, Phil Reu, Tim Miller, Steve Attaway, Mark Anderson, Enrico Quintana, John Korbin, Martin Nemer, Marcia Cooper, John Hewson, Marco Arienti, Emre Cenker, Scott Skeen, Chris Shaddix, David Kittell, Walt Gill, Bill Sweat, Megan Paciaroni, Patrick Bowden, John Yeager, Ephraim Washburn, Jian Gao, Brian Thurow, Jenna Klemkowsky, Tim Fahringer, Jun Chen, Paul Sojka, Steve Son, Michael Powell, Emre Gunduz, Varun Kulkarni, Weixiao Shang, Travis Sippel, James Michael, Mikhail Slipchenko, Naibo Jiang, Jason Mance, Sukesh Roy, Nicholas Niemiec, Waruna Kulatilaka, Zach Falgout, Cpt. Alex LeSieur, Maj. Andrew Lingenfelter, and many others....



Fragmentation Diagnostics

Fragmentation Models Need Experimental V&V



$t = 1.0 \mu\text{s}$

Experiment

10 mm

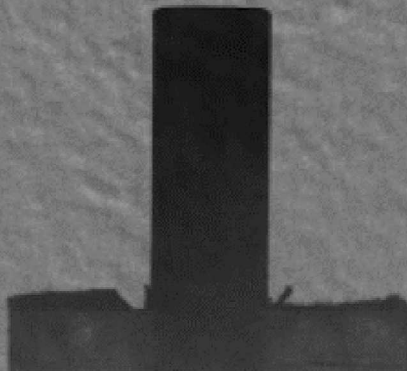

Model (Courtesy F. Perez)

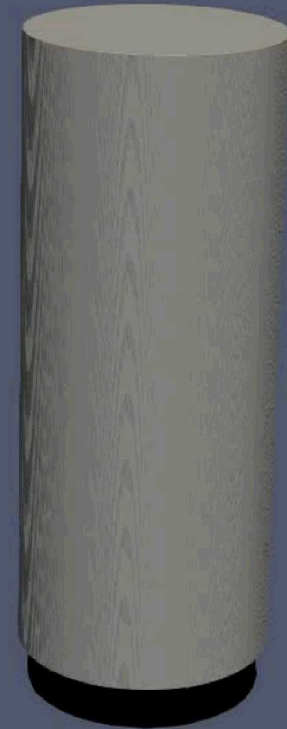

Measurement needs include:

- Initial case deformation \rightarrow DIC
- Breakup dynamics \rightarrow X-ray
- Sizes and Velocities \rightarrow Fragment Tracking

6 Fragment Tracking at 2 MHz

$t = 32.50 \mu\text{s}$

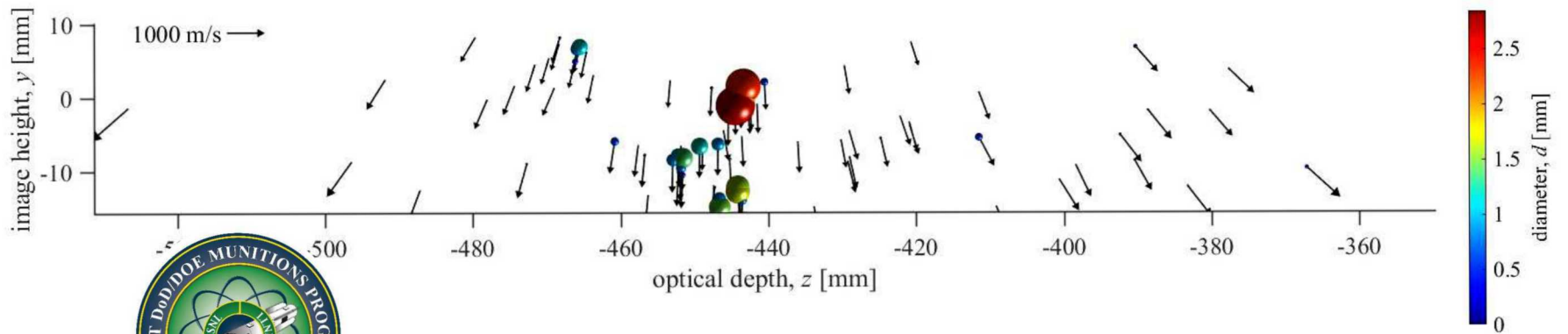
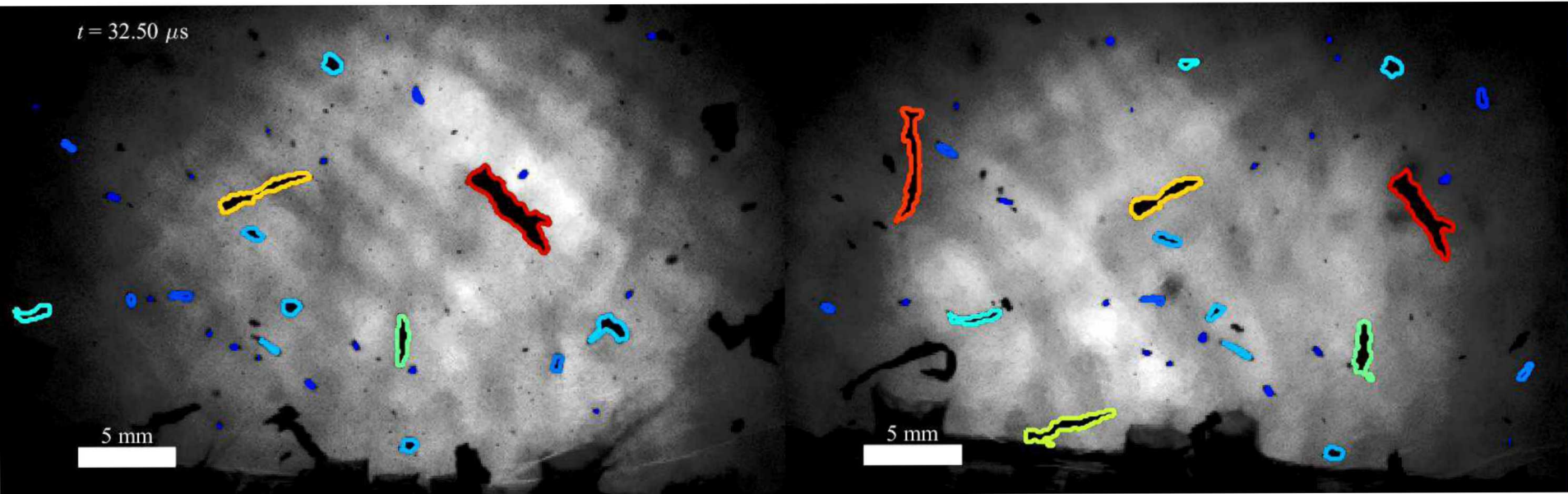

***DIC, x-ray, and fragment tracking experiments are supported by the Joint DoD/DOE Munitions Program**

*With Phil Reu, Tim Miller, Pat Ball

7 ~10 pound fragmenting explosive device at SNL

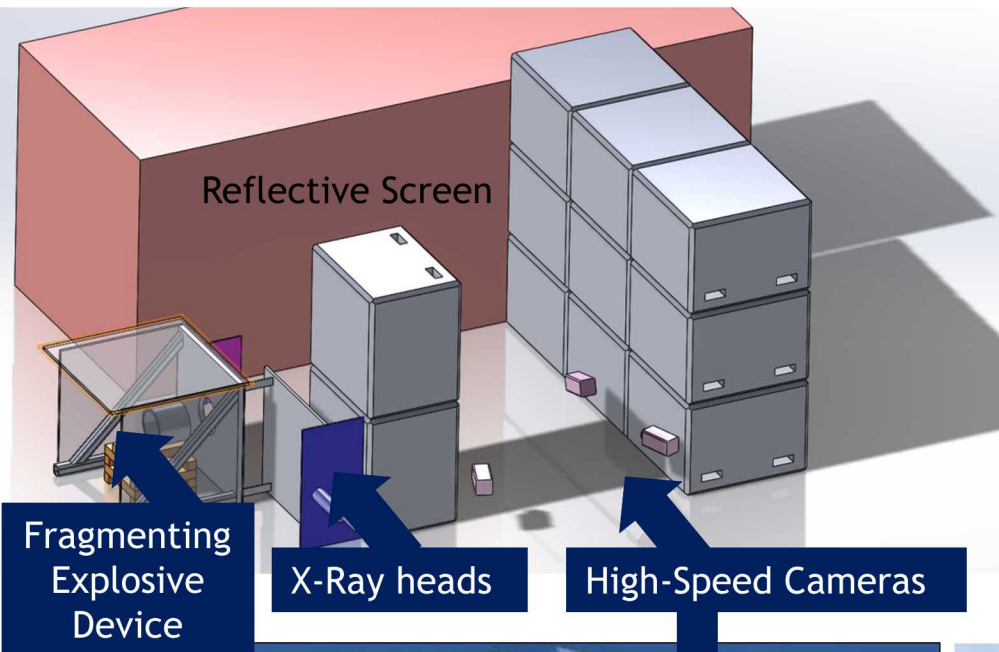

*With Phil Reu, Tim Miller, Mark Anderson, Steve Attaway, and many others

~10 pound fragmenting explosive device at SNL

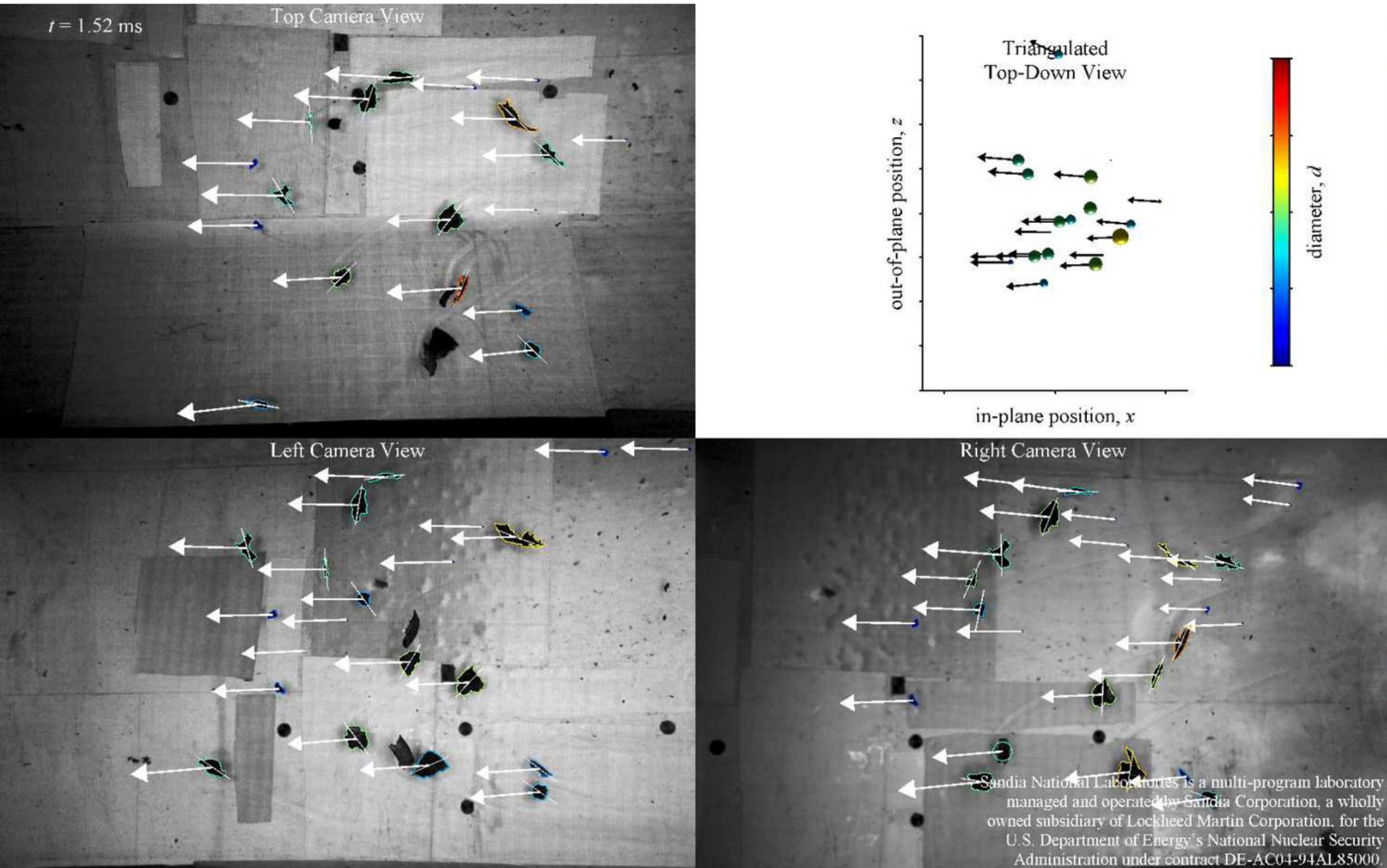

9 Plenoptic Imaging of Fragments

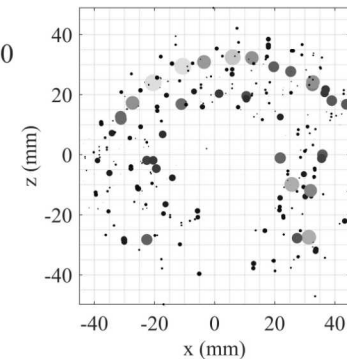
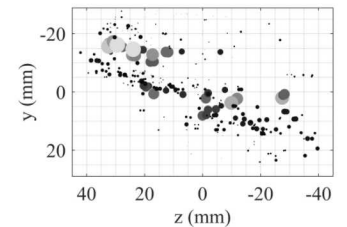
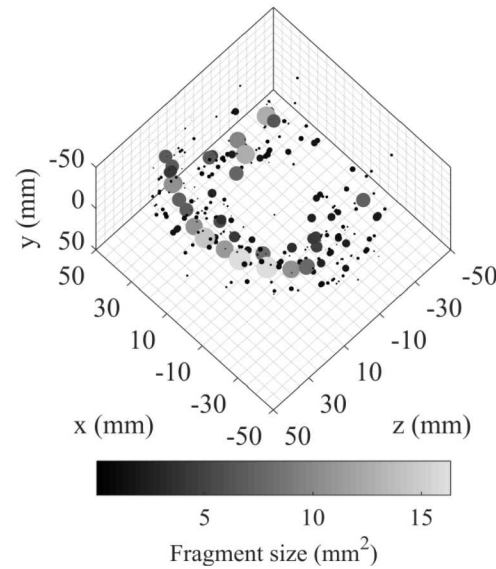
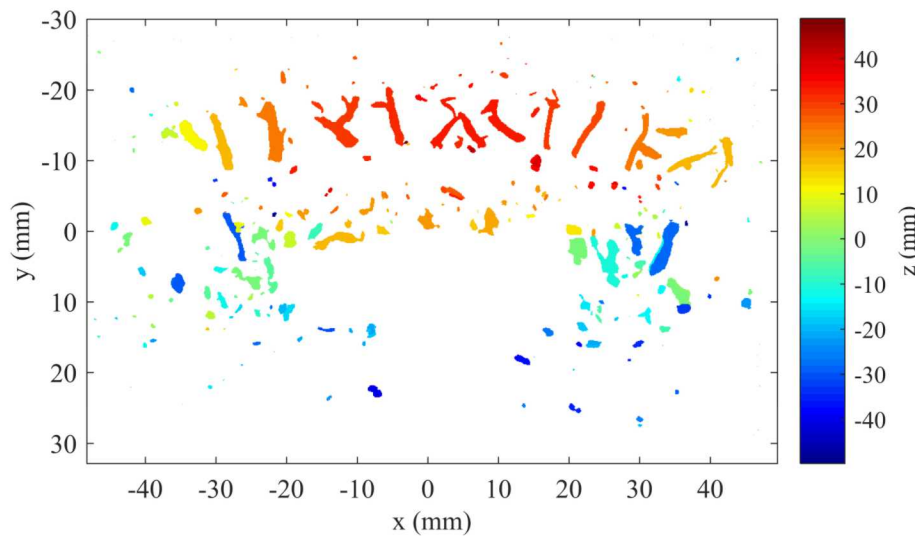
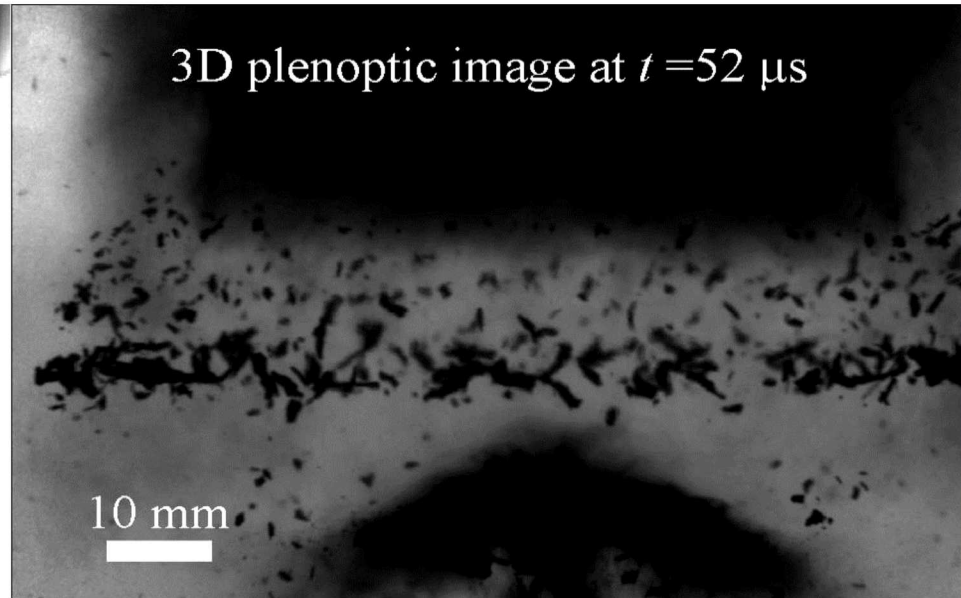
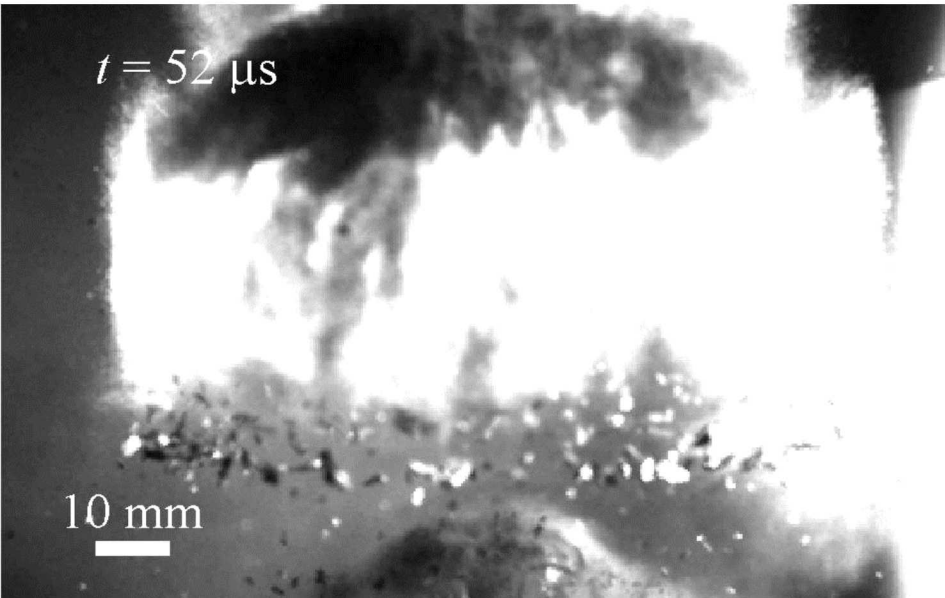

*With Elise Hall (Auburn University), Brian Thurow (Auburn University), Lee Stauffacher

Holography for Extremely Fast/Small Fragments

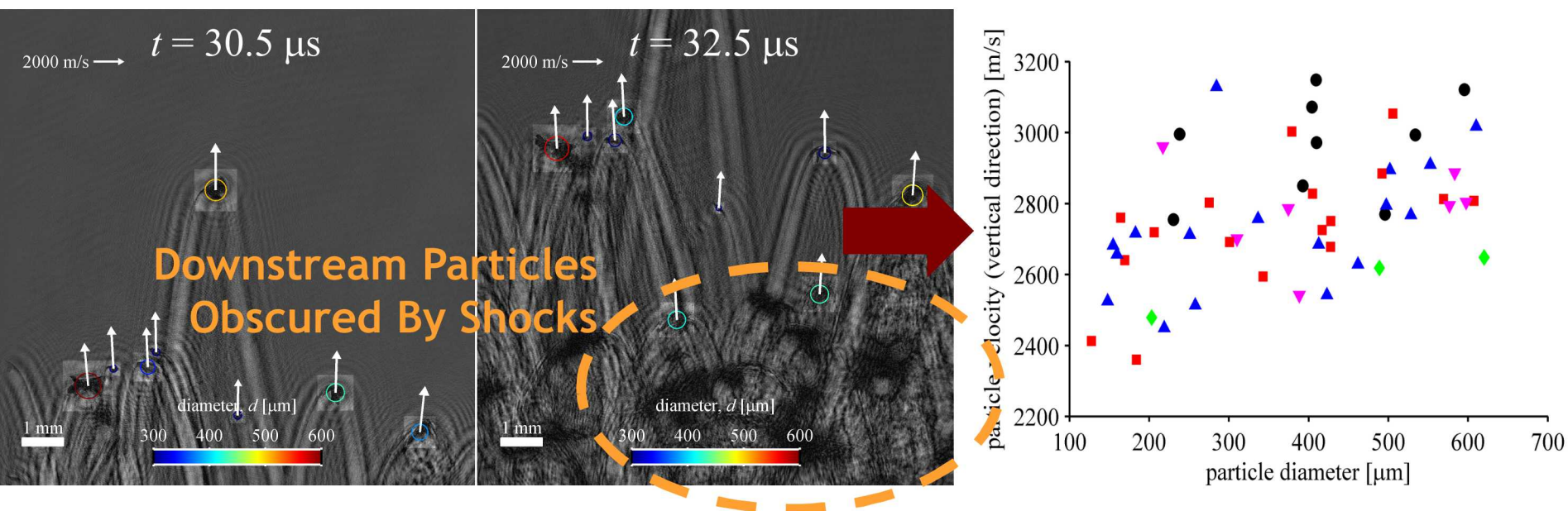
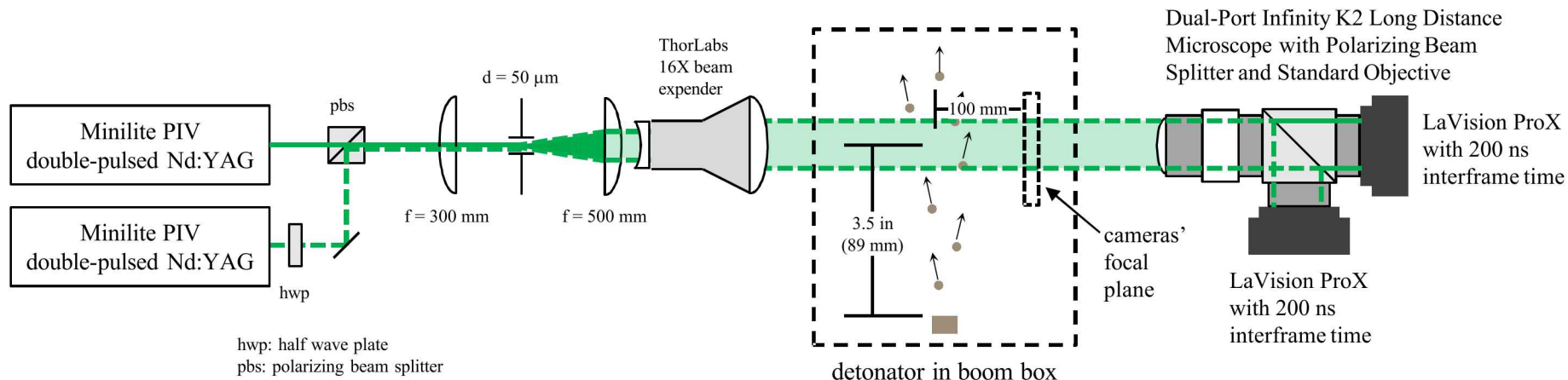

Phase Conjugate Digital Inline Holography (PCDIH)

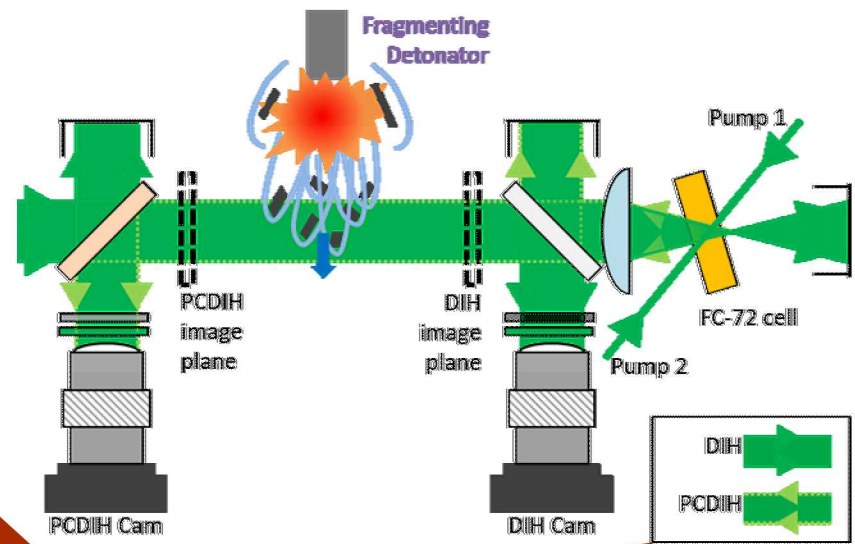

PCDIH
focused at $x = 0$

1 mm

Traditional DIH
focused at $x = 0$

1 mm

obscured
by shocks

Fragmentation Models Need Experimental V&V



$t = 1.0 \mu\text{s}$

Experiment

10 mm

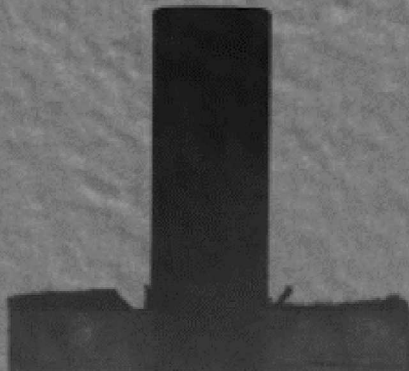

Model (Courtesy F. Perez)

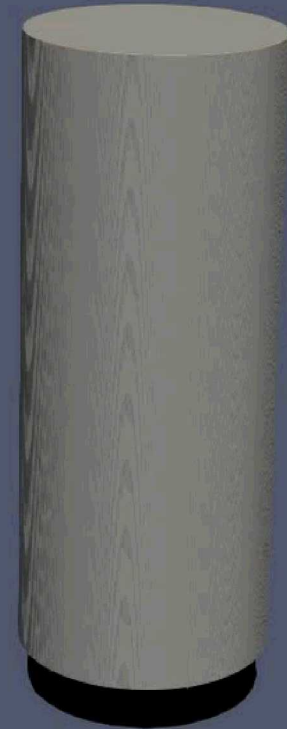

Measurement needs include:

- Initial case deformation \rightarrow DIC
- Breakup dynamics \rightarrow X-ray
- Sizes and Velocities \rightarrow Fragment Tracking

Case strain at 5 MHz (P. Reu, T. Miller)

Digital Image Correlation (DIC)

Full-field surface tracking for solid mechanics investigations

RP-80 Detonator

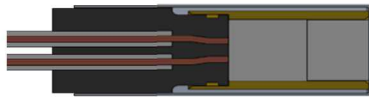

Left Camera

Right Camera

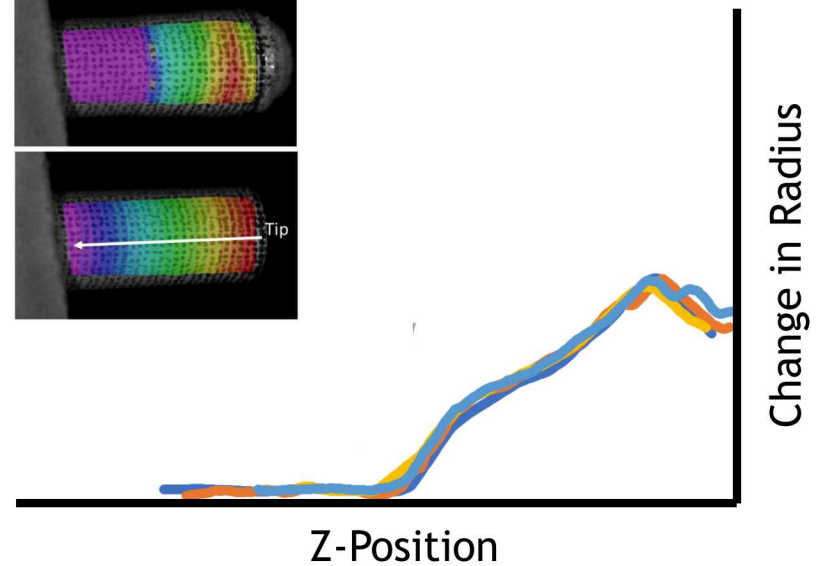
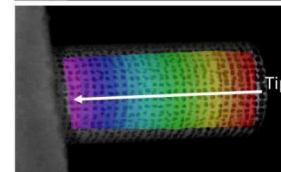
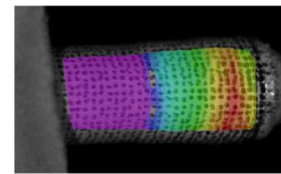
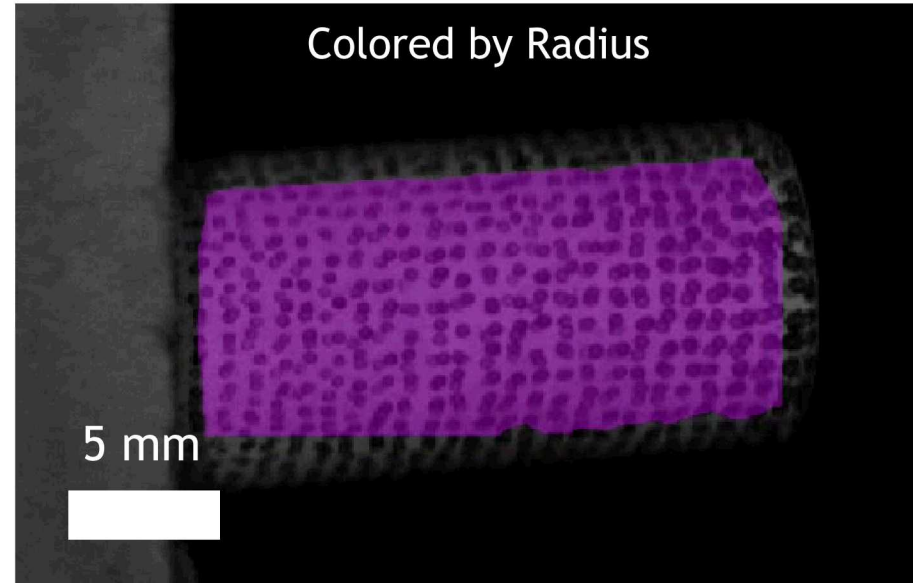
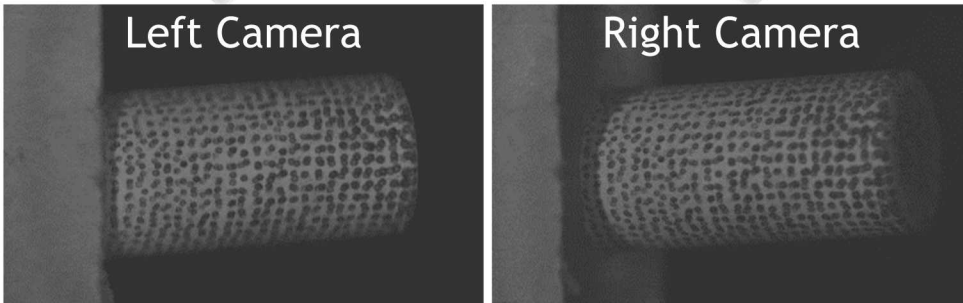

X-Ray Diagnostics at 2 MHz (B. Halls, L. Lebow)

X-rays penetrate the flash and smoke during fragmentation

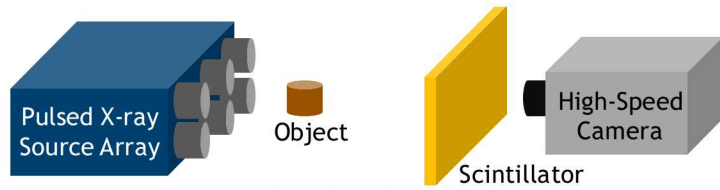

Six-Headed Flash System

Working toward:

- Continuous movies
- Tomographic reconstruction

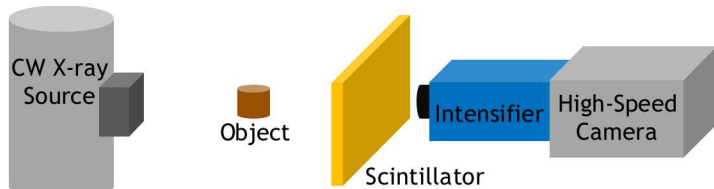

Continuous Wave System

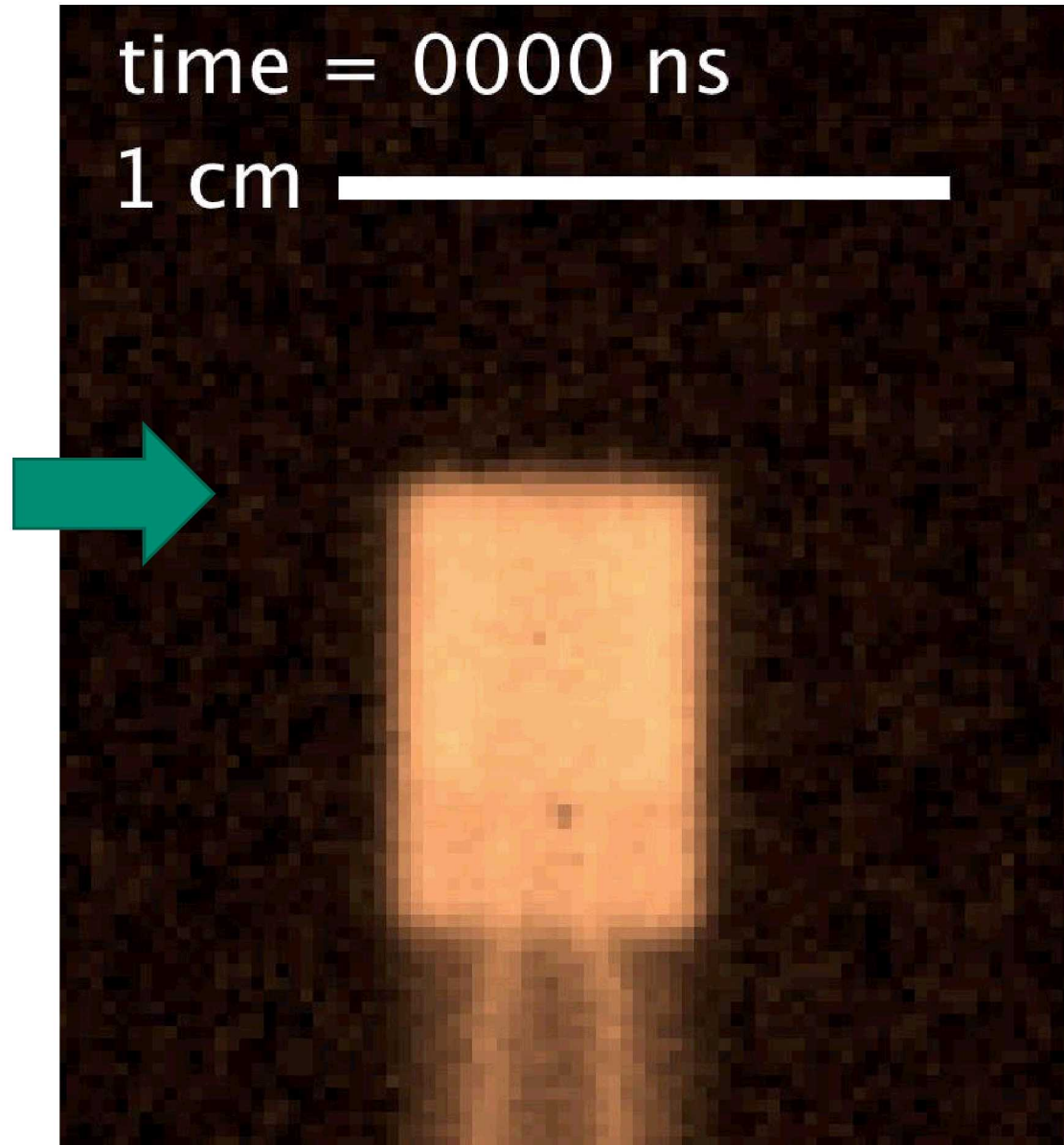

Fireball Temperature Diagnostics

Propellant Fires

Simultaneous holography and pyrometry

Size, velocity, and temperature of burning aluminum particles

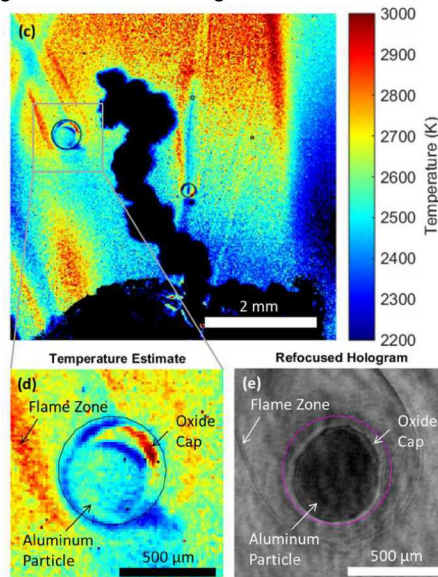
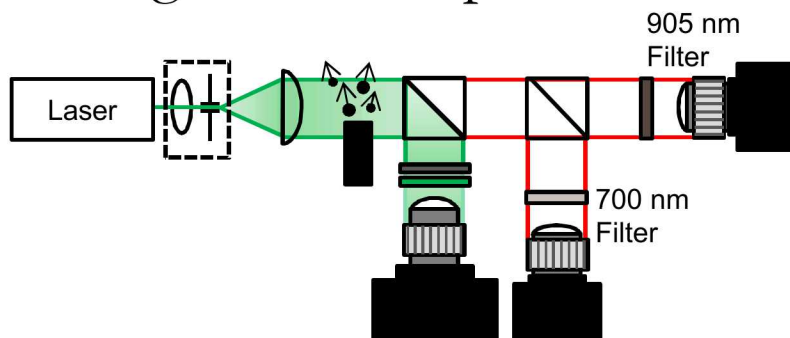

*With Yi (Ellen) Chen, Kate Hoffmeister, Marcia Cooper, Lee Stauffacher, Mike Oliver, Sean Kearney, Ephraim Washburn

N_2/O_2 Rotational Coherent Anti-Stokes Raman Scattering (CARS)

Gas-temperature and species concentrations

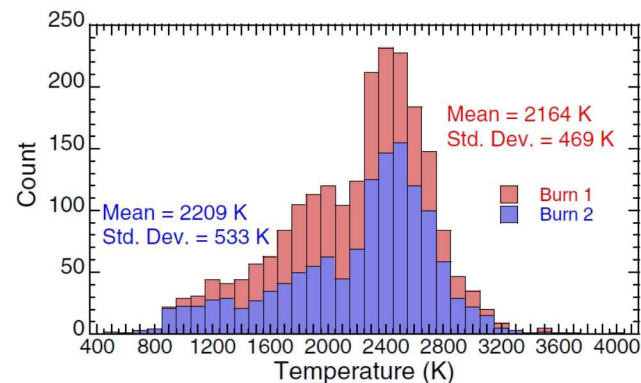
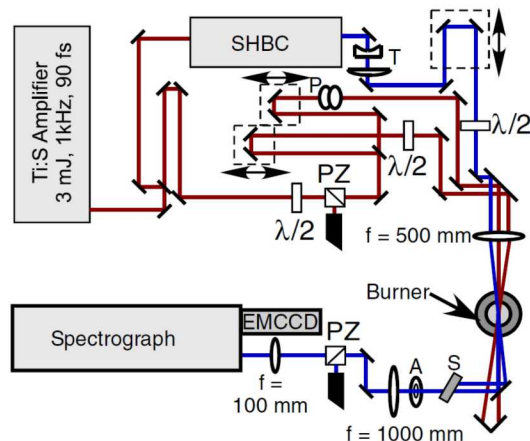

* With Sean Kearney, Lee Stauffacher

Three-Beam Vibrational Hydrogen CARS

- Decreased probe volume (~ 1.9 mm)
- Sensitivity to higher temperatures
- Directly detect a fuel produced from AP decomposition (H_2)

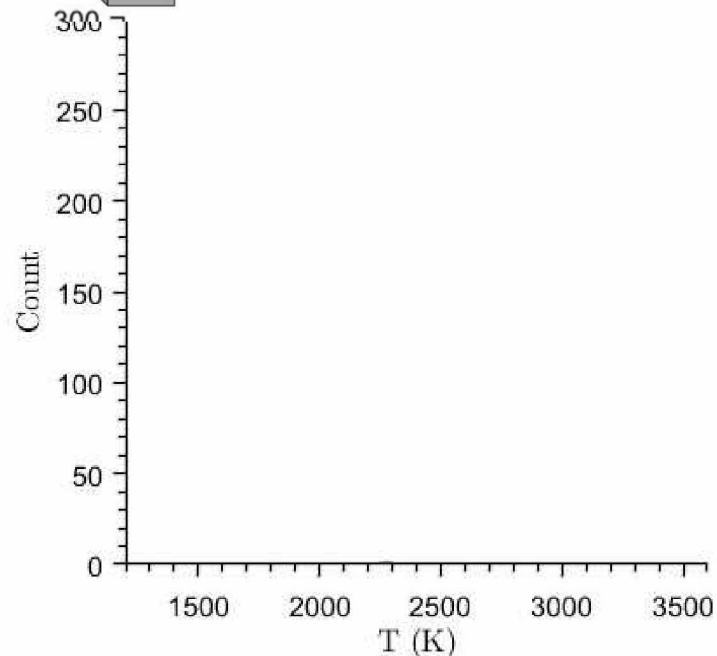
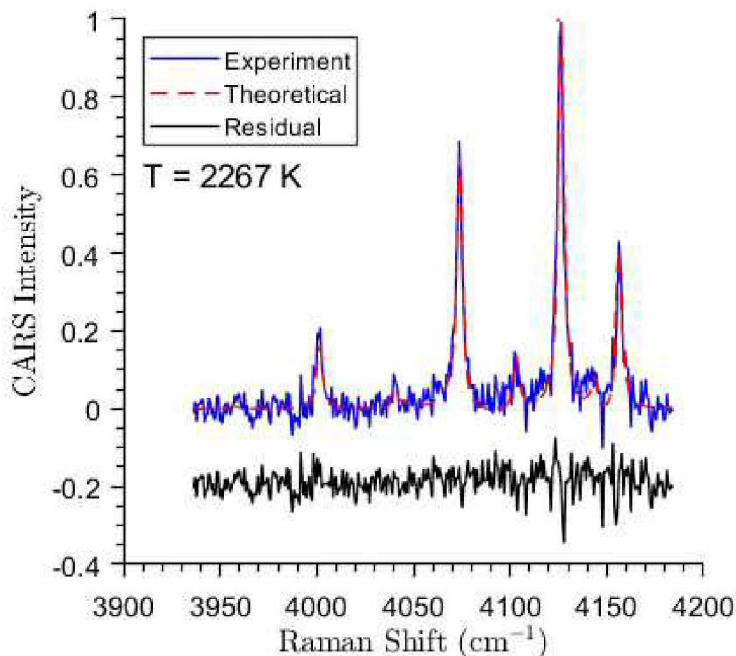
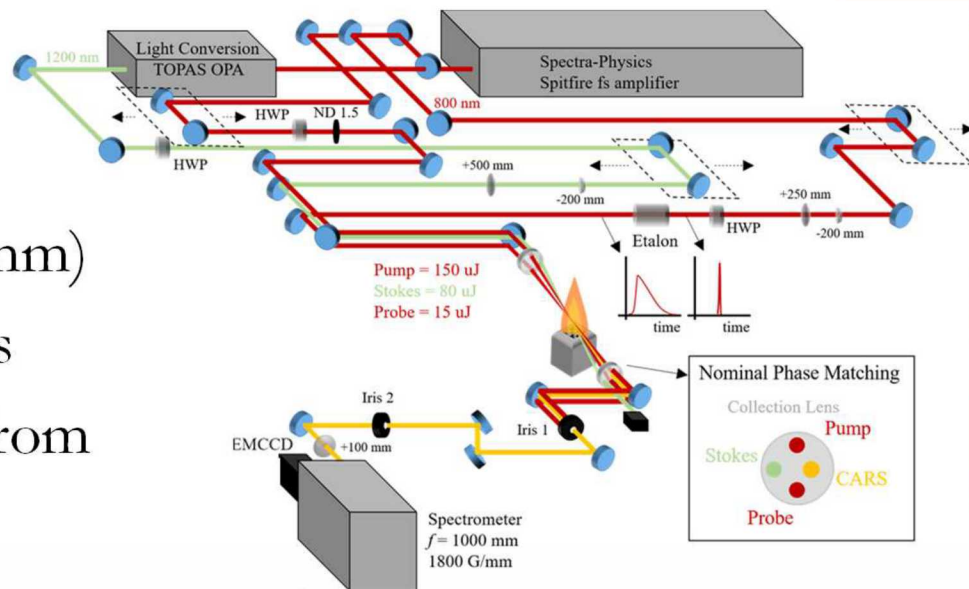

Three-Beam Vibrational Hydrogen CARS

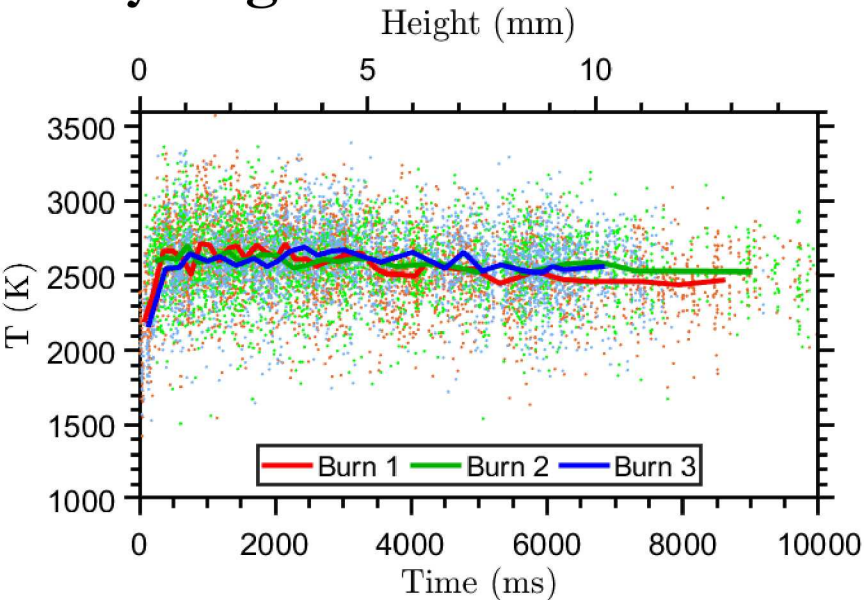

Non-intrusive diagnostics enable resolution of gas- and particle-phase temperatures in metalized fires

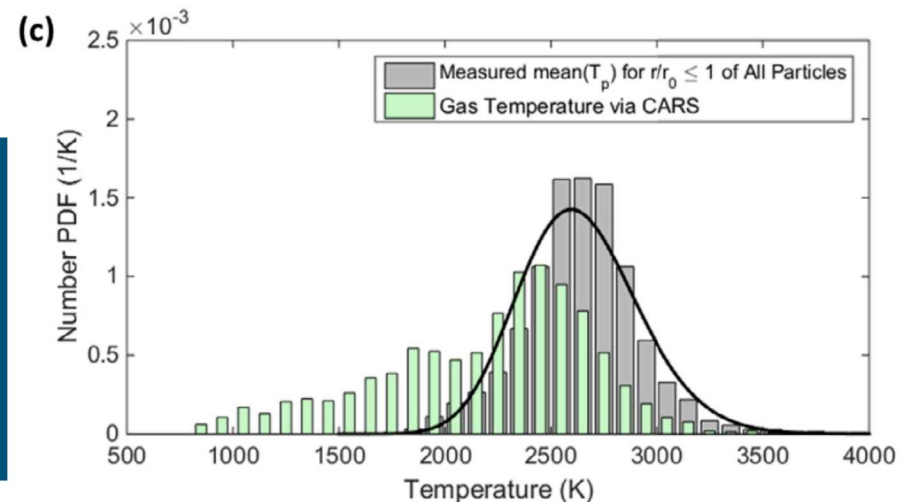
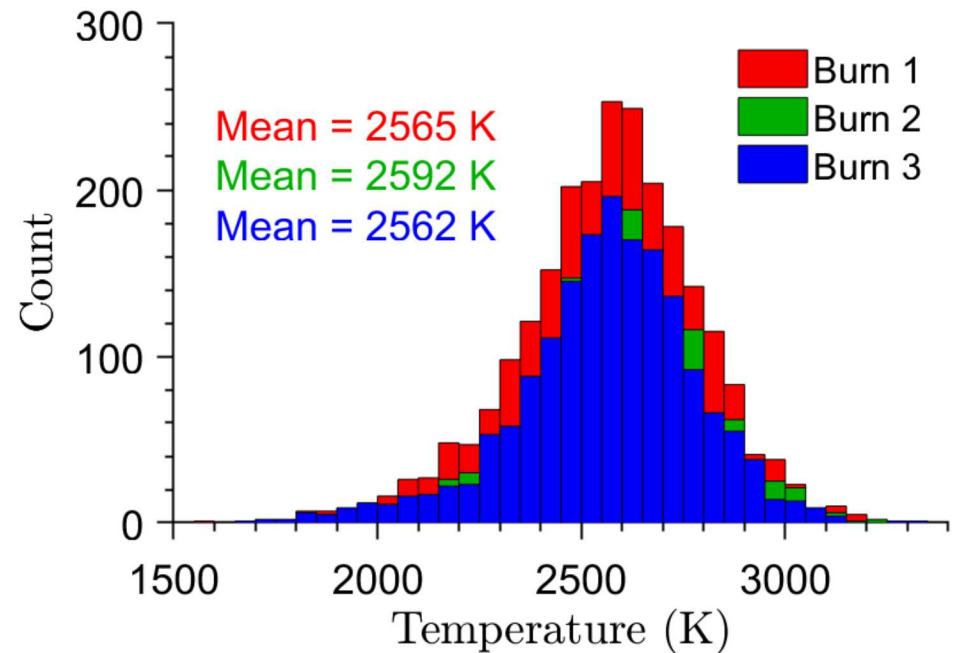

Fireball from a PBX/HMX Detonator

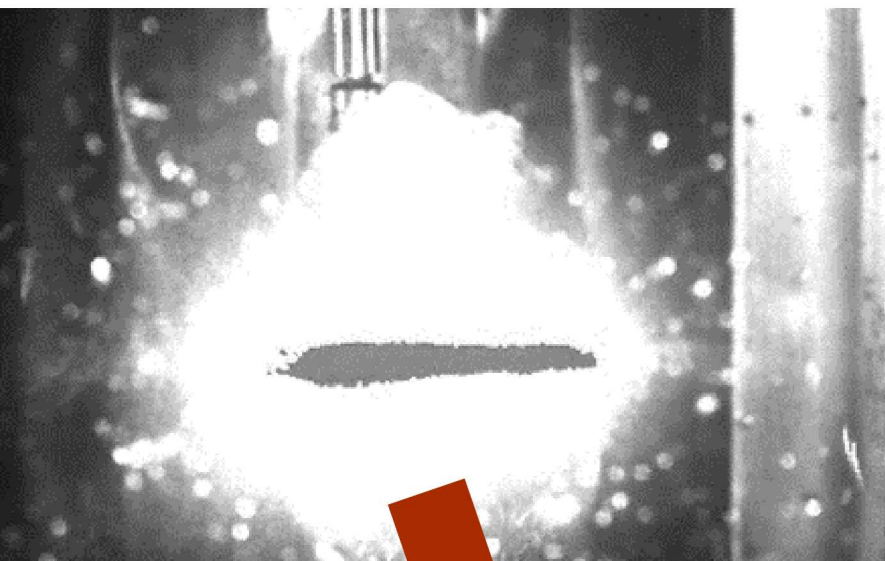

2D Hybrid fs/ps Rotational N₂ CARS

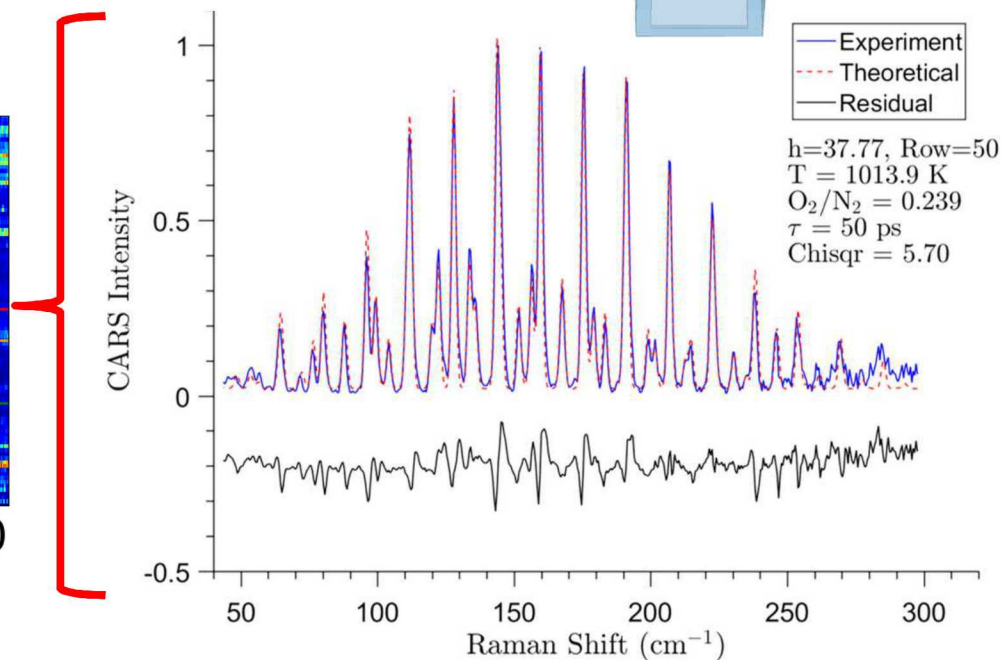
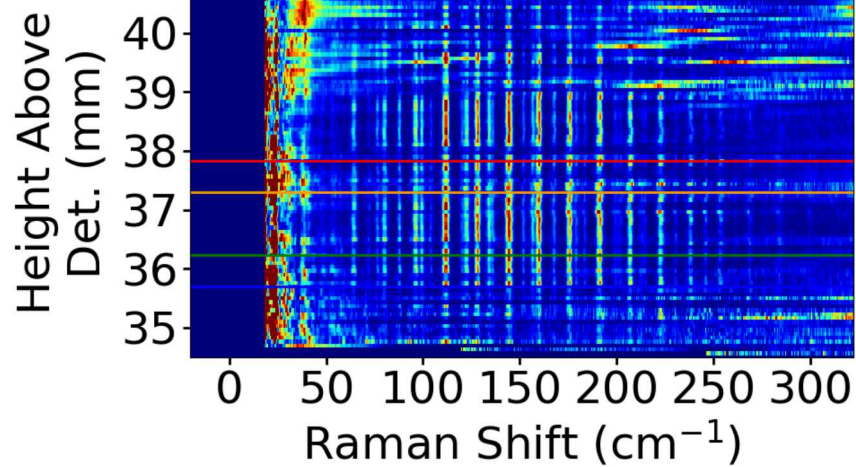
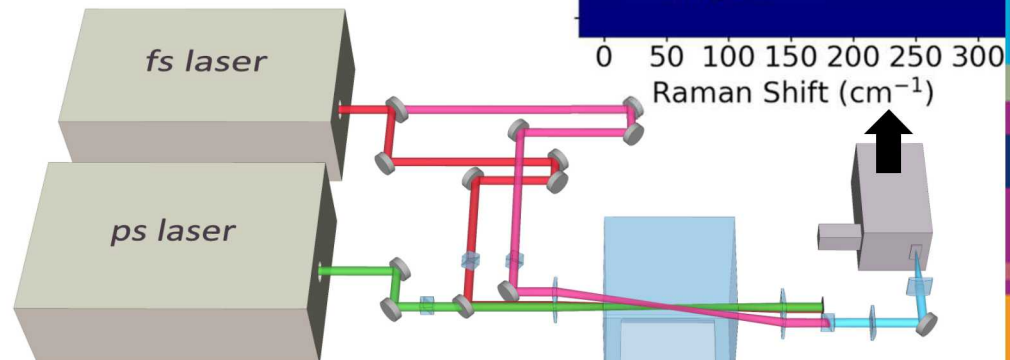

$t = 3.00 \text{ ms}$
350 m/s →

Questions?

5 cm

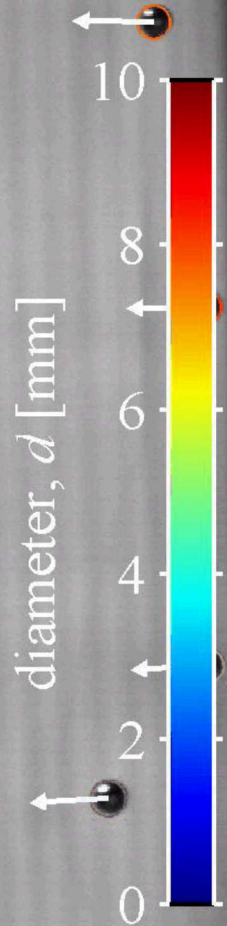

Sandia National Laboratories is a multi-program laboratory managed and operated by Sandia Corporation, a wholly owned subsidiary of Lockheed Martin Corporation, for the U.S. Department of Energy's National Nuclear Security Administration under contract DE-AC04-94AL85000.