

# Infrared absorption spectroscopy of dynamically compressed water

Darrell Ramsey<sup>a</sup>, Jason Mance<sup>b</sup>, Brandon La Lone<sup>b</sup>, Dan Dolan<sup>c</sup>

<sup>a</sup>Nevada National Security Site, New Mexico Operations, Sandia Office, 1515 Eubank SE,  
Albuquerque, NM, USA 87123

<sup>b</sup>NNSS, Special Technologies Laboratory, 5520 Ekwill Street, Santa Barbara, CA, USA 93111

<sup>c</sup>Sandia National Laboratories, 1515 Eubank SE, Albuquerque, NM, USA 87123

## ABSTRACT

Streaked visible spectroscopy is well established in dynamic compression research. Infrared measurements remain problematic, however, due to the diminishing sensitivity of streak camera photocathodes beyond 800 nm. Time-stretch techniques offer an alternative method for probing infrared features during single-event experiments. This paper discusses the development of a time-stretch spectroscopy diagnostic using dispersed supercontinuum laser pulses. The technique is applied to near-infrared measurements of liquid water during multiple shock compression.

**Keywords:** time-stretch spectroscopy, supercontinuum laser, dynamic compression research, liquid water, infrared measurements

## 1. INTRODUCTION

Supercontinuum lasers and spectral pulse dispersion have been used for spectroscopic analysis of water vapor<sup>1</sup>, and time-stretch dispersion of femtosecond laser pulses has been successfully developed at the NNSS's Special Technologies Laboratory (STL)<sup>2,3</sup> for performing ranging and high-speed velocimetry in dynamic materials experiments. Development of high-speed, dispersive infrared spectroscopy by mapping dispersed laser pulse wavelengths to time in a single detector channel is a natural synthesis of these techniques that fills a need not met by streak cameras or other existing technologies.

Interest in both developing a high-speed active infrared spectroscopy diagnostic for dynamic materials experiments and making infrared measurements of liquid water during shock compression led to this development effort involving the NNSS at STL and its New Mexico Operations Sandia Office (SO) and Sandia National Laboratories (SNL). The liquid water absorption feature of interest, a combination of symmetric and anti-symmetric OH stretch vibrations, is centered near 1450 nm. Figure 1 (from Wang, et al.<sup>4</sup>) shows the predicted transmission curve for a 200-micron-thick, double-pass water cell.

## 2. SINGLE-PULSE MEASUREMENTS

### 2.1 Time-stretch spectroscopy system

The supercontinuum laser-based diagnostic system developed at SO is shown in Figure 2. The laser infrared output is transmitted through the NKT SuperK Split beam splitter, then through 1250 nm long-pass and 1600 nm short-pass filters, defining the final spectral range. A combination of optical fiber modules temporally disperses the pulse to fill the 12.8 ns period of the 78 MHz repetition rate laser. A reference signal is tapped off while the majority of the beam (30 mW) is carried via SMF-28 single mode fiber to a "soft collimation" gradient index (GRIN) lens probe. The signal beam passes through the water target cell mounted on the test sample and is reflected then coupled back through the GRIN lens to a 50-micron graded index multi-mode fiber. Both the reference and the signal beams couple to high-speed InGaAs detectors on a high-speed digitizer.

The NKT laser generates a supercontinuum by illuminating a photonic crystal fiber with a 1064 nm short-pulse laser source. This method of supercontinuum generation is noisy and creates significant pulse-to-pulse spectral variation<sup>5</sup>. Compensating for this pulse-to-pulse spectral variation is the key challenge for this system, and real-time monitoring is essential. Figure 3 shows static measurements from a gold reflector and water sample with individual laser pulses. The top plots are reference

signals, which are carefully aligned with the target signals (middle plots). The signal ratios displayed in the bottom plots are proportional to gold reflectance and water transmission.

## 2.2 Veloce experiment

Veloce is a pulsed-power machine for ramp-wave compression to 20+ GPa peak pressures (Figure 4) over a few hundred nanoseconds. The water cell in this work is constructed from 3D printer parts, dispensing needle fill tubes, epoxy, and a sapphire window. The sapphire window has an air/sapphire anti-reflection coating on the outside and water/sapphire anti-reflection coating on the cell side. Because the Veloce target is at ambient atmospheric pressure, no special effort was needed to ensure vacuum compatibility.

Figure 5 shows the water cell transmission ratio and raw photonic Doppler velocimetry (PDV) data from the onset of ramp compression ( $\sim 1.3 \mu\text{s}$  after trigger), through an apparent rebound, and to cell destruction at  $3.5 \mu\text{s}$  after trigger. The region of interest that might show water absorption line changes is near the initial velocity/pressure peak. Transmission through the water cell decreases after peak pressure, but it doesn't become completely opaque. A sequence of individual absorption profiles is shown for comparison with a pre-experiment average.

The average profile has significant modulation due to water cell etalon effects and interference effects from other reflections. Fine fringes come from the 90-micron water cell, which becomes thinner during sample compression. The larger fringes on the short wavelength side of the plots are from reflections not immediately affected by compression, presumably from reflections outside the sample.

## 3. MULTIPLE PULSE MEASUREMENTS

A similar time-stretch spectroscopy system was developed at STL with a different supercontinuum laser. Due to extreme variations in this laser, multiple-pulse averaging was needed to obtain useful spectral ratios. Shock reverberation experiments were used to extend and hold the compression of liquid water over a longer period of time to support such averaging.

Figure 6 shows the STL water cell and gas-launched impactor. There are several important features of this arrangement. First, the 16 mm thick by 41 mm diameter sapphire window maintains one-dimensional compression for several microseconds, allowing supercontinuum laser pulses to be averaged over nearly static pressures. Second, the mirror for reflecting the supercontinuum beam is on the back side of the impactor face piece, protecting it from the initial impact shock. Third, the PDV measurement on the thick sapphire window is optically isolated from the water sample, eliminating scattering/absorption effects that might compromise this diagnostic. Finally, the large angle between the supercontinuum transmit and receive fibers reduces interference effects.

Figure 7 shows a spectrogram of the water absorption profile in terms of optical frequency and wavelength as the shock travels through the water cell. The velocity profile overlaid on the spectrogram indicates the 6 GPa pressure peak where the spectral shift shown in the lower plot occurs.

The optical shift, though small, seems clear in the presented data. The spectrogram shows low intensity variation and few interference artifacts after impact. This would indicate the experiment configuration with the supercontinuum reflecting surface behind the impactor face piece is effective at reducing spurious signals.

## 4. CONCLUSION

A high-speed time-stretch spectroscopy diagnostic was successfully developed and used to investigate near-infrared absorption in water absorption under dynamic compression. The time-stretch spectroscopy technique itself is notable, and interest is growing in looking at other chemicals and surfaces under dynamic stress environments. Future work could include moving the spectral window to longer wavelengths or different wavelength bands, looking at metal surface reflectivity under dynamic stress, and configuration changes such as pulse dispersion after target interrogation. The STL experiment demonstrated a small shift in the 1450 nm water absorption feature to lower optical frequency (longer wavelength) during dynamic compression. The SO experiment was not conclusive, indicating that higher pressure and/or additional diagnostic refinement is needed for single-pulse measurements.

## ACKNOWLEDGMENTS

This manuscript has been authored by Mission Support and Test Services, LLC, under Contract No. DE-NA0003624 with the U.S. Department of Energy and supported by the Site-Directed Research and Development Program, National Nuclear Security Administration, NA-10 USDOE NA Office of Defense Programs (NA-10). The United States Government retains and the publisher, by accepting the article for publication, acknowledges that the United States Government retains a non-exclusive, paid-up, irrevocable, worldwide license to publish or reproduce the published form of this manuscript, or allow others to do so, for United States Government purposes. The U.S. Department of Energy will provide public access to these results of federally sponsored research in accordance with the DOE Public Access Plan (<http://energy.gov/downloads/doe-public-access-plan>). The views expressed in the article do not necessarily represent the views of the U.S. Department of Energy or the United States Government. DOE/NV/03624--0687.

Sandia National Laboratories is a multi-mission laboratory managed and operated by National Technology and Engineering Solutions of Sandia LLC, a wholly owned subsidiary of Honeywell International Inc. for the U.S. Department of Energy's National Nuclear Security Administration under contract DE-NA0003525. This paper describes objective technical results and analysis. Any subjective views or opinions that might be expressed in the paper do not necessarily represent the views of the U.S. Department of Energy or the United States Government.

## REFERENCES

- [1] Werblinski, T., Engel, S. R., Engelbrecht, R., Zigan, L., and Will, S., "Temperature and multi-species measurements by supercontinuum absorption spectroscopy for IC engine applications," *Opt. Express* 21(11), 13656-13667 (2013).
- [2] La Lone, B. M., Marshall, B. R., Miller, E. K., Stevens, G. D., Turley, W. D., and Veerer, L. R., "Simultaneous broadband laser ranging and photonic Doppler velocimetry for dynamic compression experiments," *Rev. Sci. Instrum.* 86(2), 023112 (2015).
- [3] Mance, J. G., La Lone, B. M., Dolan, D. H., Payne, S. L., Ramsey, D. L., Veerer, L. R., "Time-stretched photonic Doppler velocimetry," *Opt. Express* 27(18) 25022-25030 (2019).
- [4] Wang K., Wen, W., Wang, K., He, J. Wang, J., Zhai, P., Yang, Y., and Qui, P., "Order-of-magnitude multiphoton signal enhancement based on characterization of absorption spectra of immersion oils at the 1700-nm window," *Opt. Express* 25(6), 5909-5916 (2017).
- [5] Agrawal, G., [Nonlinear Fiber Optics Fifth Edition], Academic Press, Waltham, MA, 553-597 (2012).

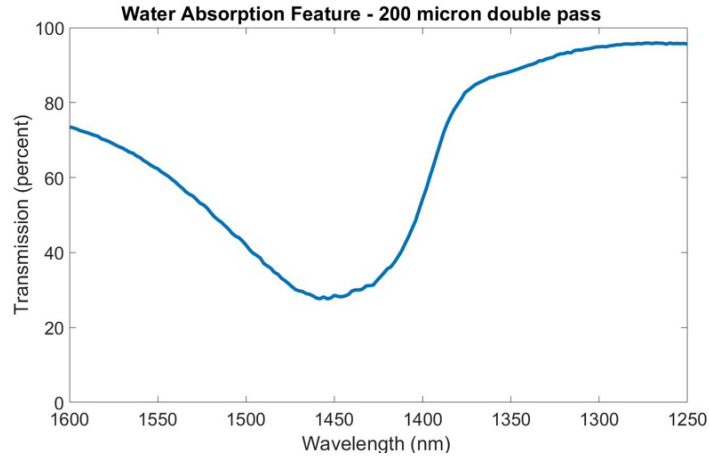

Figure 1. Water transmission profile for 200-micron double pass transmission (wavelength range is from 1600 to 1250 nm to match appearance of digitizer data).

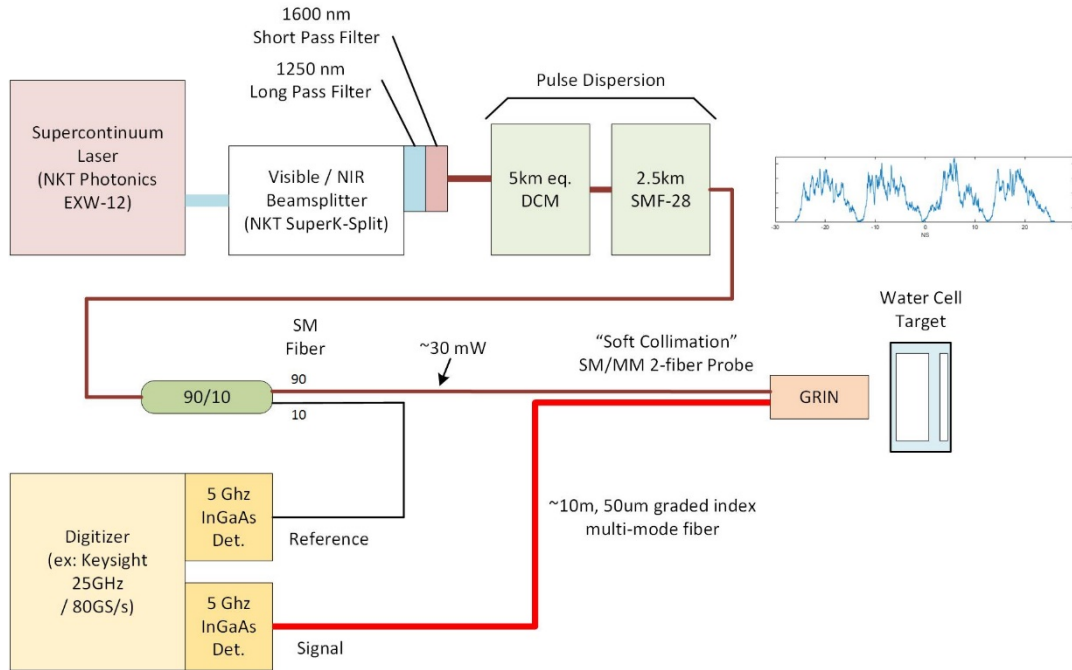

Figure 2. Time-stretch spectroscopy system.

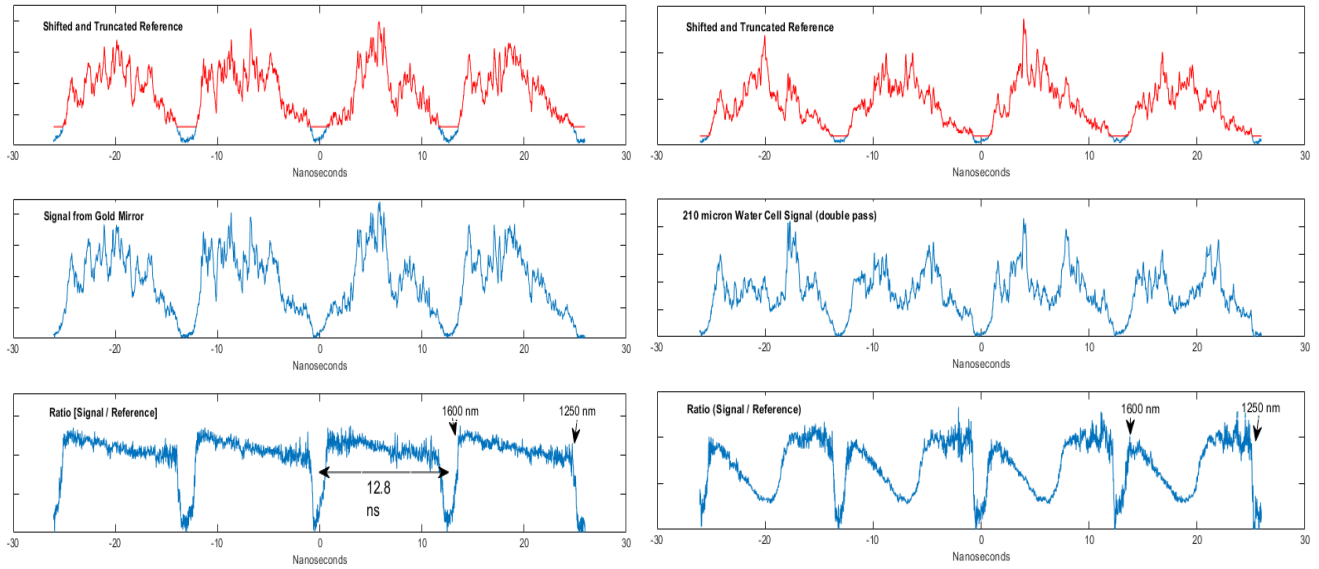

Figure 3. Single sample shifted reference, target signal, and calculated ratio pulses for gold sample (left) and a double-passed 210-micron water sample (right).

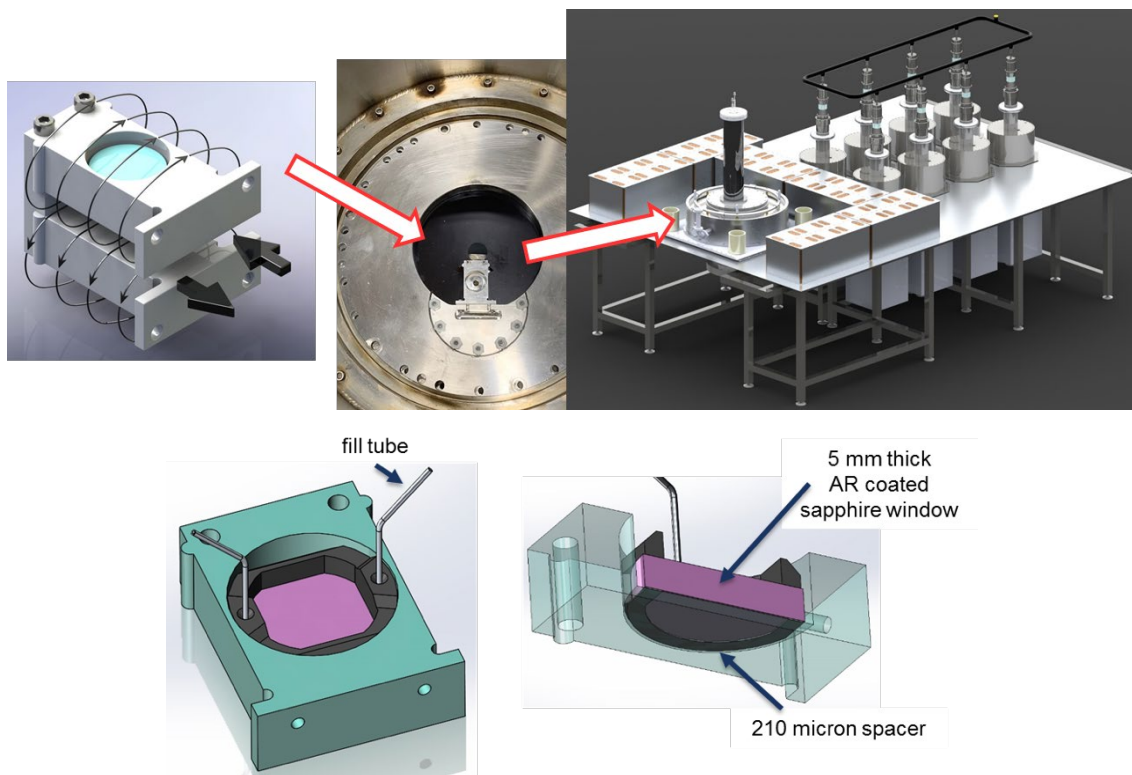

Figure 4. (top) Veloce machine with detail showing experiment panels and current pulse direction through panel pair with magnetic fields. (bottom) Water cell panel detail showing 5mm thick sapphire window with 210-micron water cell spacer and fill tubes.

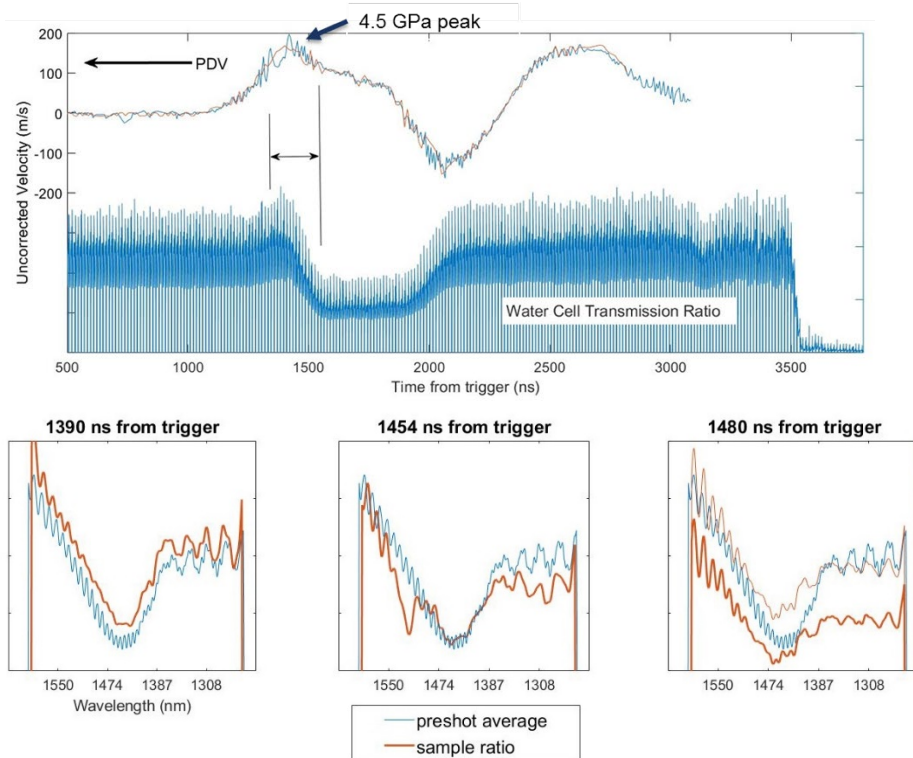

Figure 5. (top) PDV and water cell ratio data from experiment V548. The region of interest is marked with a double arrow. (bottom) Ratio spectra comparison before and during sample compression.

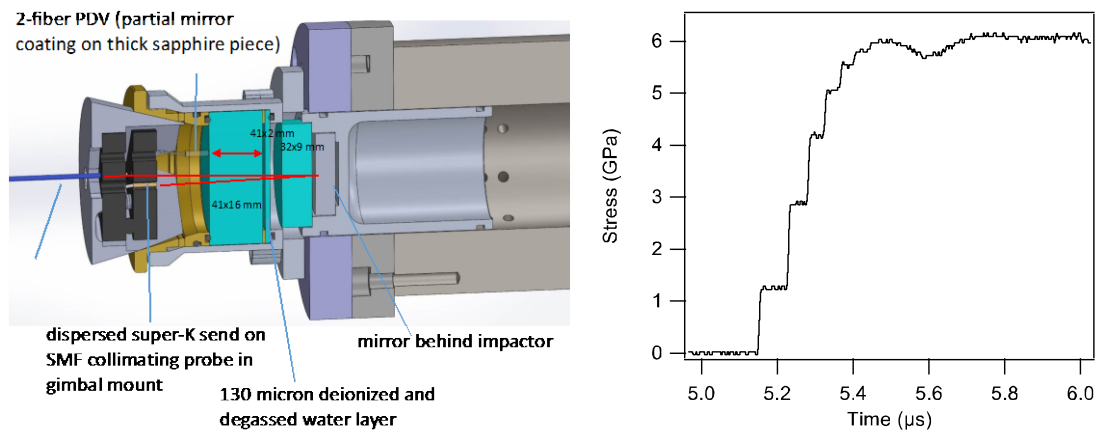

Figure 6. STL gas gun experiment (left) compresses liquid water via multiple shock jumps (right).

**Spectrogram (dark blue at ~ 205 THz is the absorption band)**

optical interference fringes between impactor and target just before impact (fixed phase at 232 THz and 198.9 THz because Doppler shift frequency (275 m/s impact) is integer multiple of laser repetition rate)

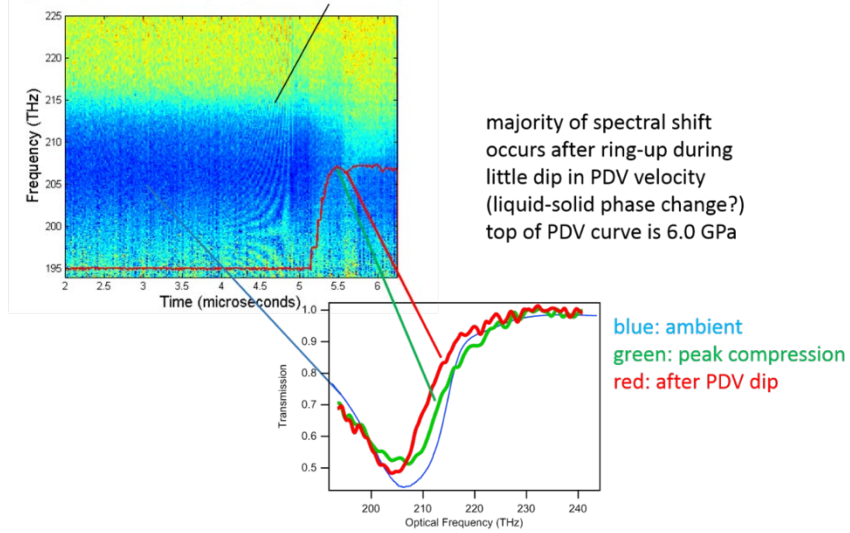

Figure 7. STL experiment results. Absorption curve shown in units of optical frequency instead of wavelength.