

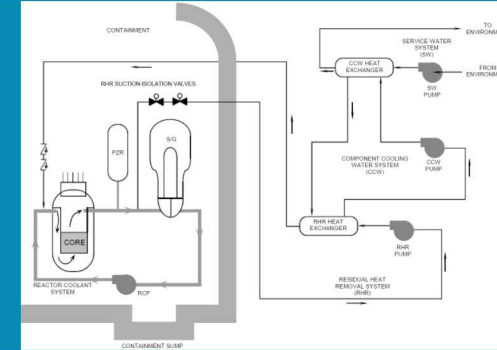

A Dynamic Coupled-Code Assessment of Mitigation Actions in an Interfacing System Loss of Coolant Accident



Zachary Jankovsky*, Matthew Denman*, Tunc Aldemir⁺

*Sandia National Laboratories ⁺The Ohio State University



Sandia National Laboratories is a multimission laboratory managed and operated by National Technology and Engineering Solutions of Sandia LLC, a wholly owned subsidiary of Honeywell International Inc. for the U.S. Department of Energy's National Nuclear Security Administration under contract DE-NA0003525.

- This work was supported by the Laboratory Directed Research and Development program at Sandia National Laboratories under a partnership with The Ohio State University Nuclear Engineering Program.
- Sandia National Laboratories is a multimission laboratory managed and operated by National Technology and Engineering Solutions of Sandia LLC, a wholly owned subsidiary of Honeywell International Inc. for the U.S. Department of Energy's National Nuclear Security Administration under contract DE-NA0003525.

- Dynamic PRA
- ADAPT Overview
- Plant & Transient
- Dynamic Modeling
- Results & Analysis

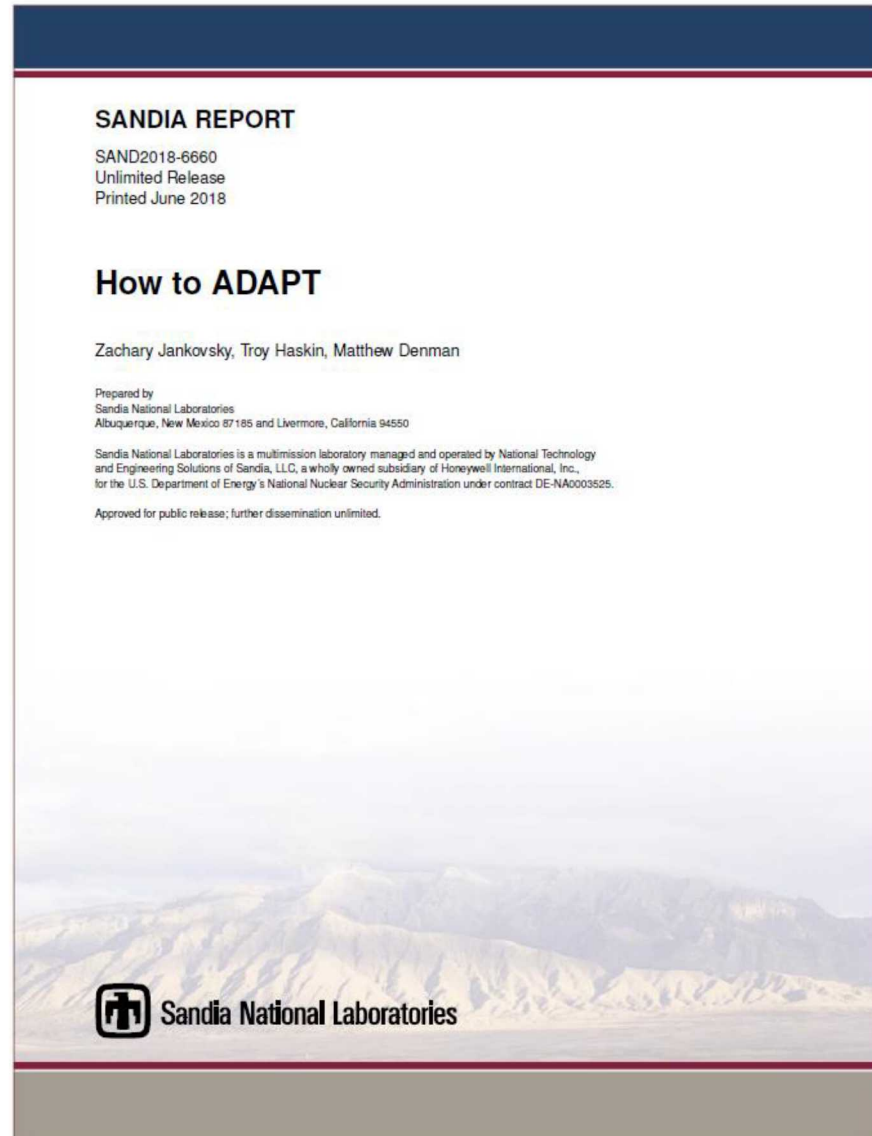

Dynamic Probabilistic Risk Assessment (PRA)



- Traditional PRA requires analysts to assume order of events
 - Does not explicitly account for timing of events
 - Will an event have different effects on incident progression based on its timing?
 - Uncertainties in event ordering increase with incident complexity and time
- Dynamic PRA is driven by time-resolving models of the relevant phenomena
 - Events occur according to physically-meaningful rules
 - E.g., hydrogen igniter success is queried only when a combustible mixture has accumulated
 - Events may re-occur as appropriate (e.g., valve failure query on cycling)
 - Dynamic event trees (DETs) are easily incorporated into a traditional PRA

ADAPT Approach



- DET driver developed for/by SNL (2006-present)
 - Tracks DET database, launches jobs, and presents results
 - Jobs may be run on local machines up to HPCs
 - Supports linking multiple simulator codes
 - Calculates figures of merit using time-dependent output data
- Simulator- and domain-agnostic
 - Simulators must meet a short list of requirements
 - Capable of restarting from saved state with new input
 - Simulator interactions performed via signal files rather than shared memory
 - Traceability
 - Portability over diverse computational hosts

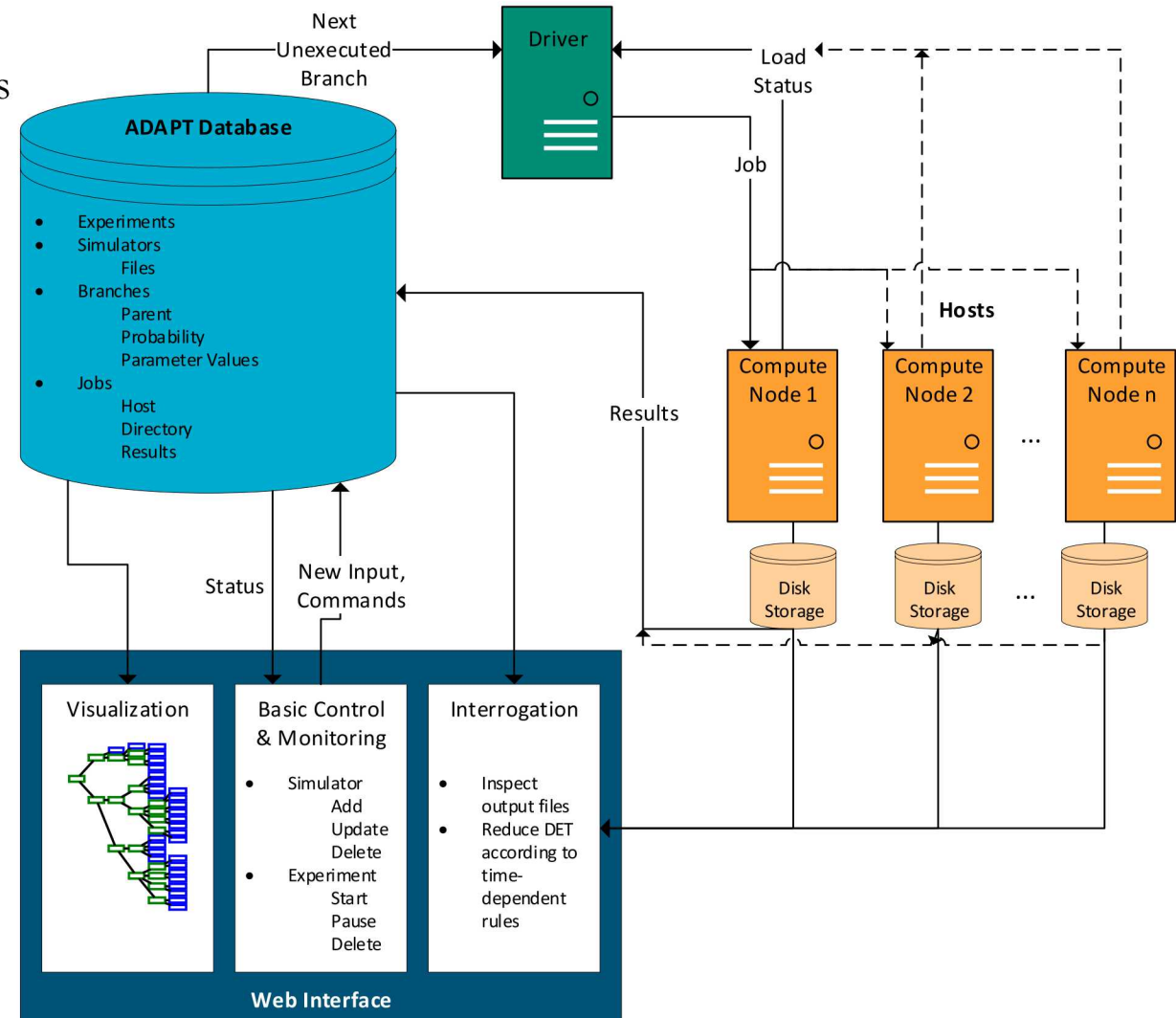



Years	System	Incident	Simulator(s)
2006-2011	PWR	SBO	MELCOR
2009	SFR	Aircraft Crash	RELAP5
2013	PWR	SBO	MELCOR
2013-2014	PWR	SBO	MELCOR
2014	HTGR	LOFC	MELCOR
2015-2017	PWR	SBO	MAAP4
2015-2017	SFR	TOP	SAS4A/SASSYS-1
2015-2018	PWR	ISLOCA	MELCOR, RADTRAD
2015-2018	BWR	SBO	MELCOR
2016-2018	SNF Cask	Derailment	STAGE, RADTRAN

PWR: Pressurized Water Reactor
 SFR: Sodium-cooled Fast Reactor
 HTGR: High Temperature Gas-cooled Reactor
 BWR: Boiling Water Reactor
 SNF: Spent Nuclear Fuel

SBO: Station Blackout
 LOFC: Loss of Forced Cooling
 TOP: Transient Overpower
 ISLOCA: Interfacing System Loss of Coolant Accident

ADAPT Timeline

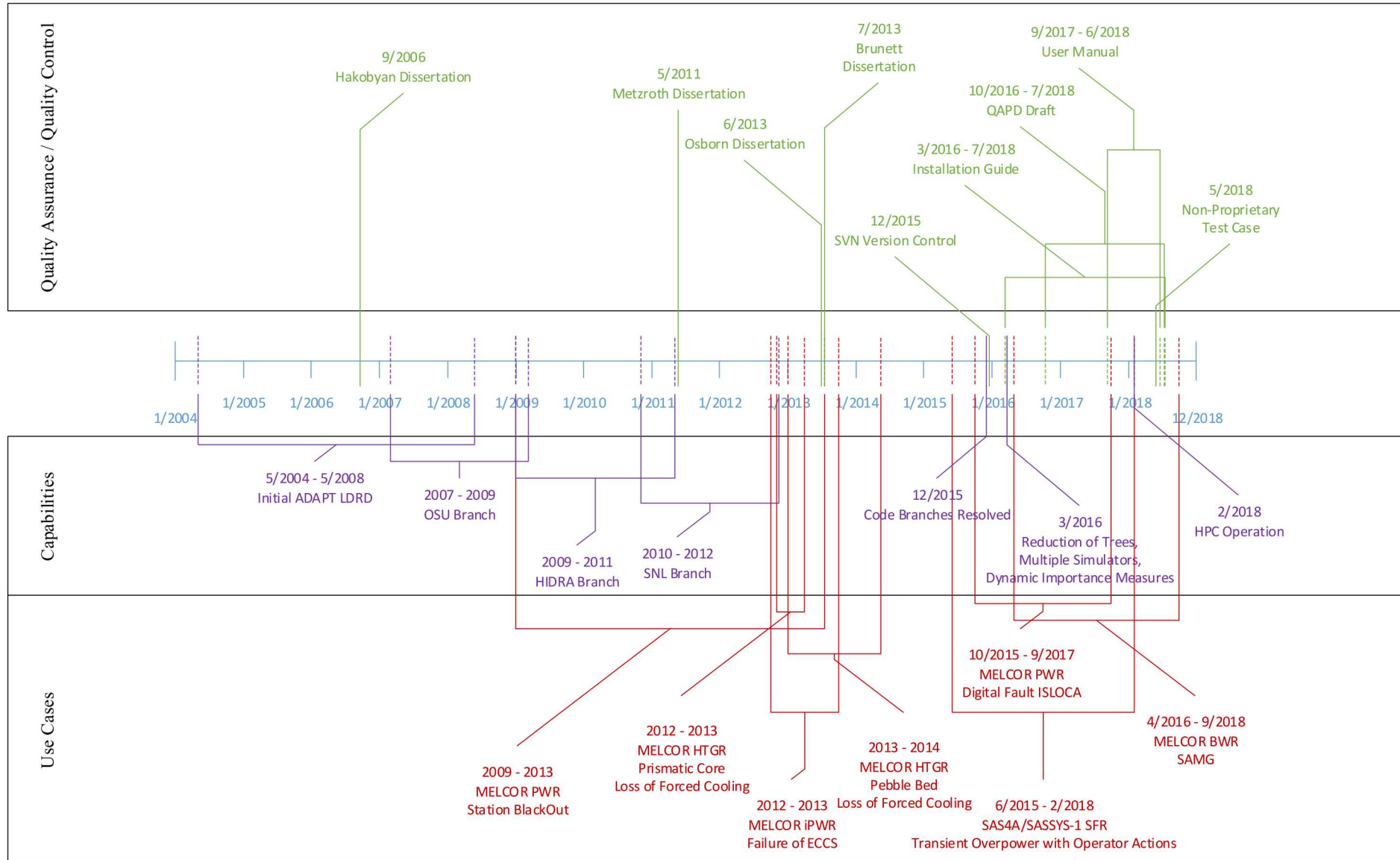

Interfacing System Loss of Coolant Accident (ISLOCA)



- ISLOCAs have the potential for large early release due to containment bypass
- Residual heat removal (RHR) ISLOCA
 - Damage to equipment used for safe shutdown
 - Rapid depressurization
 - Difficult to analyze in traditional PRA
 - Common practice is to assume core damage if isolation is lost at power
- Dynamic coupled-code analysis
 - Consider evolution of auxiliary building conditions for operator action success
 - Room flooding, modeled in MELCOR
 - Radiation hazards, modeled in RADTRAD
 - Investigate effects of input parameters on plant state and release fractions



- RHR outside of containment
 - Components reside in lowest level of auxiliary building
 - Shares pumps with low pressure safety injection (LPSI)
 - Suction and return lines must penetrate containment
 - Suction line isolated by motor-operated valves (MOV) in series
 - Interlocked against high reactor coolant system (RCS) pressure
 - RCS operating pressure 15.5MPa
 - RHR design pressure 2MPa
 - Interfaces with component cooling water (CCW) system
- CCW provides cooling to numerous systems
 - LPSI/RHR pumps
 - High pressure safety injection (HPSI) pumps

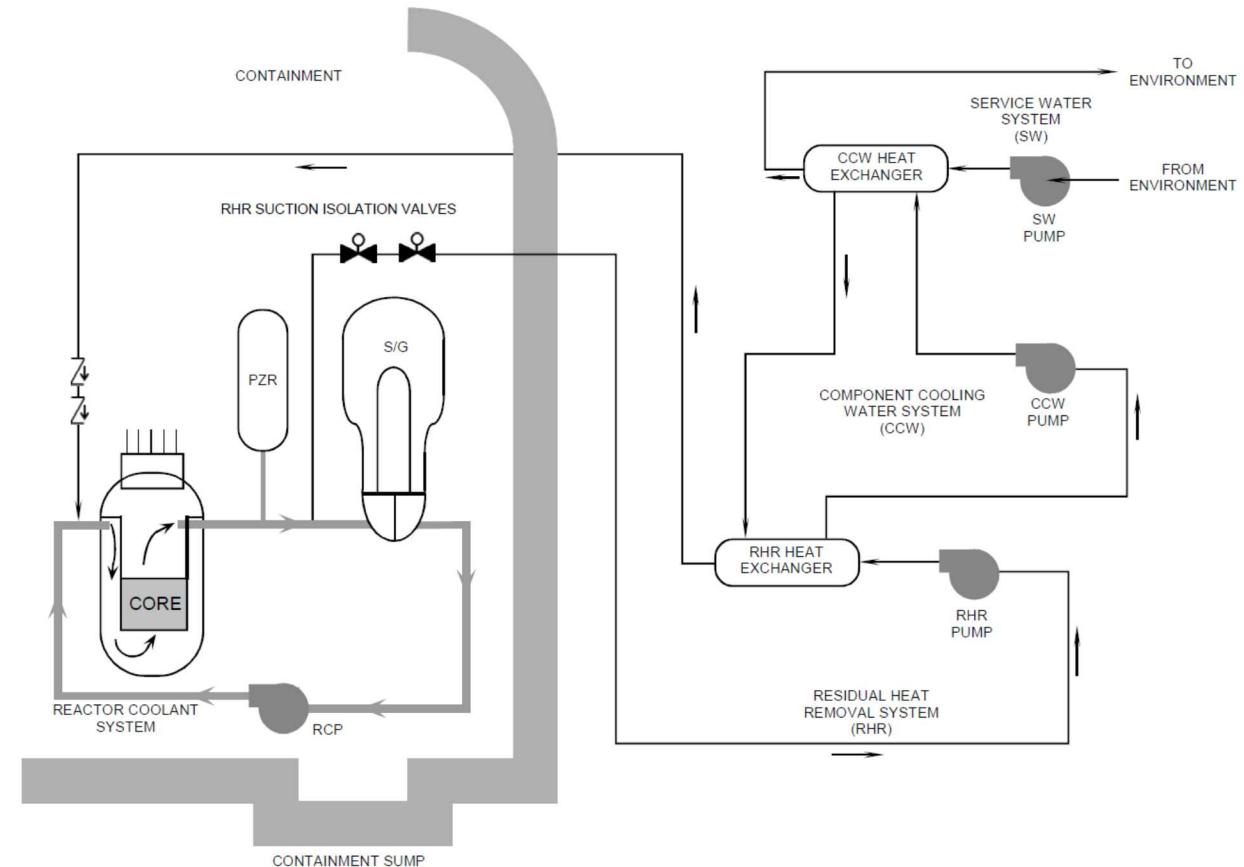

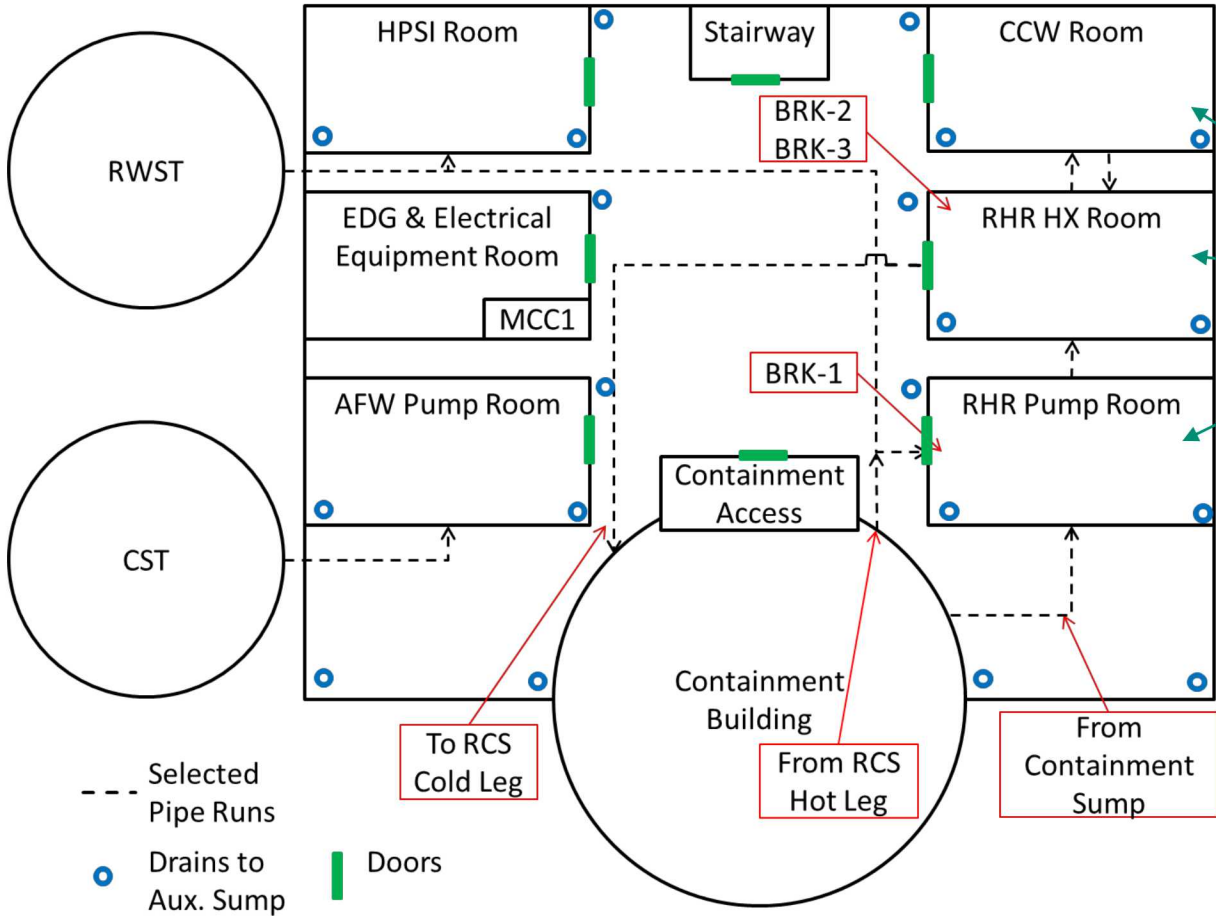

- Manual valves relating to RHR and CCW in equipment rooms
- Isolation of CCW from RHR
- Bypass of failed RHR heat exchanger (HX)
- Isolation of RHR from RCS
- Doors and drains will influence flooding
- Operators may be hampered by flooding or radiation
 - RCS inventory spilled into rooms

--- Selected Pipe Runs
 ○ Drains to Aux. Sump
 █ Doors

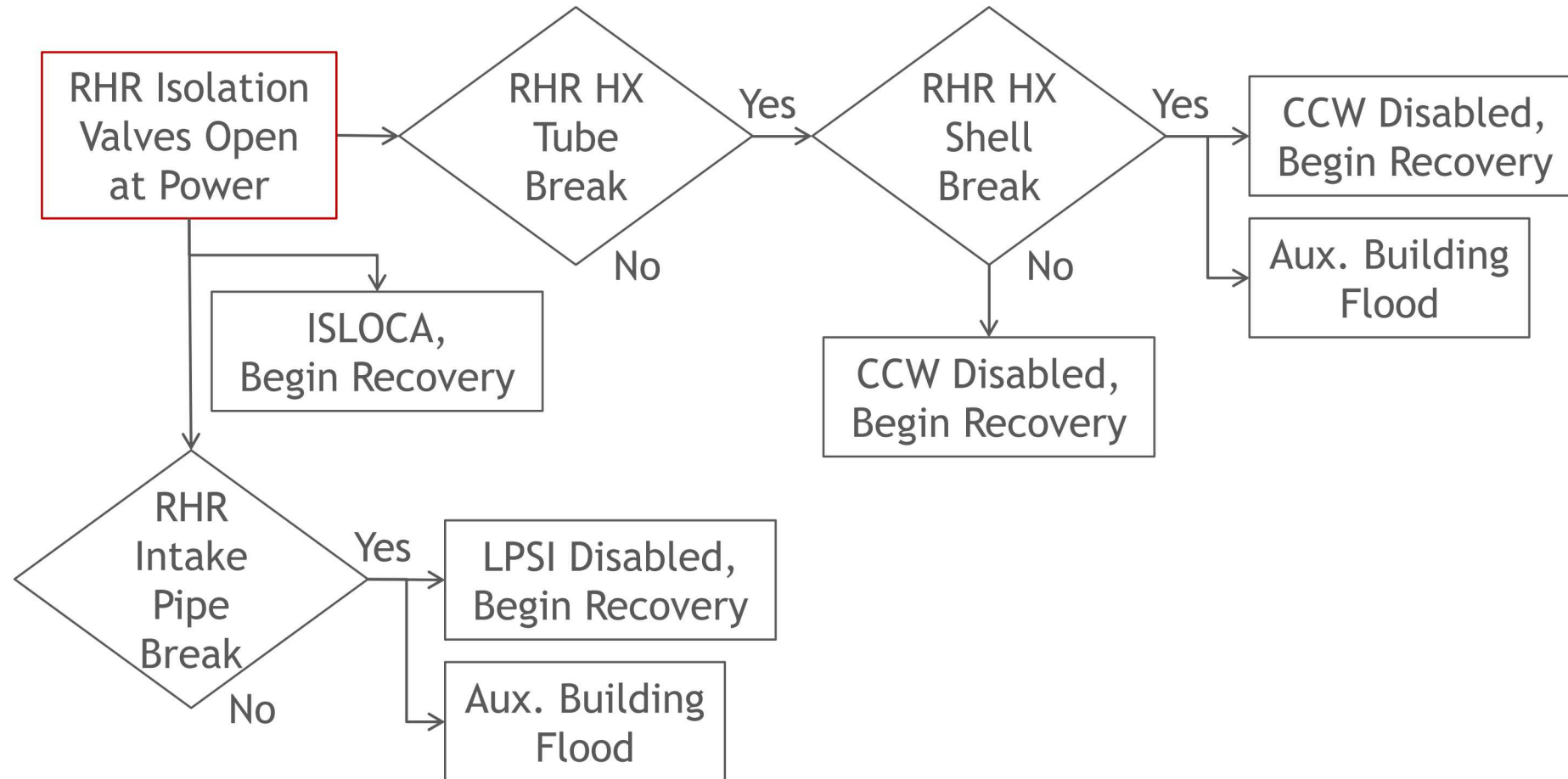



- Procedures emphasize depressurization after ISLOCA diagnosed
 - Direct inventory into containment through pilot-operated relief valve (PORV)
 - Preferable to releasing inventory to auxiliary building
 - Water may collect in sump for later use in mitigating accident
- RHR ruptures must be isolated from rooms in the auxiliary building
 - Uncertain success and timing
 - May be defeated by high water level or high radiation
 - Uncertain operator dose tolerance

- General accident progression evolves in MELCOR under ADAPT
 - MELCOR is a severe accident analysis code developed for the United States Nuclear Regulatory Commission (USNRC)
- RADTRAD is run under ADAPT when operator doses must be calculated
 - RADTRAD is a radionuclide transport, removal, and dose calculation code developed for the USNRC

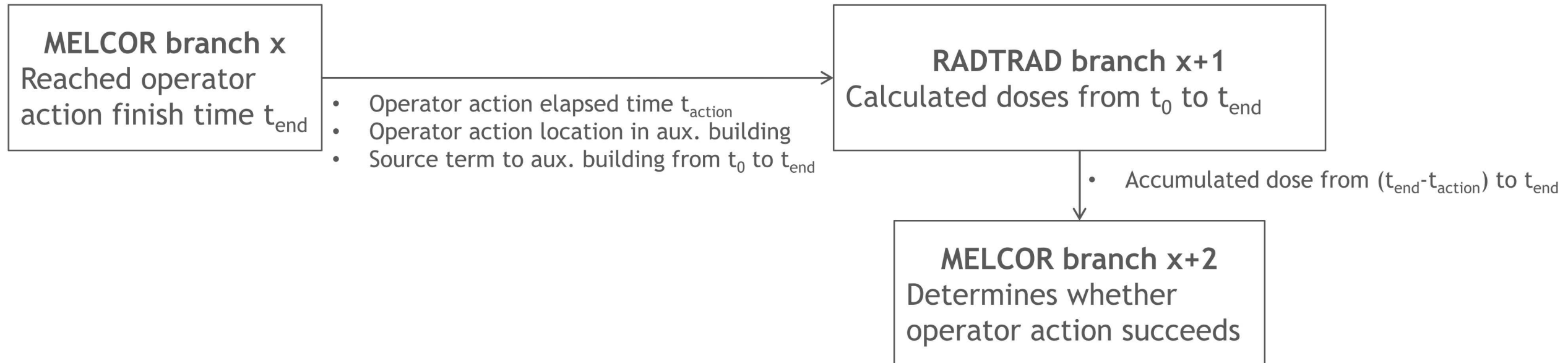



- Auxiliary building doors may have failed seals or be left open

Initial Door Status	RHR Pump Room Door Status	Closed	0.97
		Open	0.03
	RHR HX Room Door Status	Closed	0.97
		Open	0.03

- Operator dose tolerance

- Crew will have limited information regarding the physical state of the plant

Dose Tolerance	Operator Dose Tolerance	5 rem	1/3
		25 rem	1/3
		No limit	1/3

- Ending conditions

- 24 hours simulation time
- 90% of fuel intact



- Uncertain pressure capacity of RHR components

Break Location	RHR Suction Pipe Capacity	{	4.2 MPa	0.1
		{	8.9 MPa	0.8
		{	16 MPa	0.1
	RHR HX Tube Capacity	{	7.8 MPa	0.1
		{	11 MPa	0.8
		{	16 MPa	0.1
	RHR HX Shell Capacity	{	6.1 MPa	0.1
		{	9.4 MPa	0.8
		{	15 MPa	0.1

- Uncertain success of mitigation actions

Mitigation Action Success	PORV Blowdown	Success	0.97
		Failure	0.03
	RHR Pump Suction Isolation	Success	0.97
		Failure	0.03
	RWST Isolation from RHR	Success	0.97
		Failure	0.03
	RHR HX Tube Isolation	Success	0.97
		Failure	0.03
	RHR HX Shell Isolation	Success	0.97
		Failure	0.03

- Uncertain timing of mitigation actions given success
 - Only actions taken outside the control room
 - Actions taken from control room timed using SOARCA ISLOCA simulation results
 - HPSI/LPSI not available until any RHR HX ruptures isolated from CCW

Mitigation Action Timing	RHR Pump Suction Isolation Timing	{	393 s	0.1
		{	608 s	0.8
		{	1050 s	0.1
	RHR HX Tube Isolation Timing	{	393 s	0.1
		{	608 s	0.8
		{	1050 s	0.1
	RHR HX Shell Isolation Timing	{	393 s	0.1
		{	608 s	0.8
		{	1050 s	0.1

Results (1/7)



- Not all sequences ran to completion
 - 1,448,618 branches identified
 - 697,663 completed
 - 46.7TB of data
- Scoping is important
 - Originally run with internal failure events as well



/home/zkjaniko/ADAPT/ADAPT/server/adapt-plot-horsetails 79 dscplot_CVH-P520 Primary Pressure (Pa) -useolddata true -useprocessors 10 -maxtimegap 1000.0 -fraction 0.05
zkjaniko@tree.sandia.gov:export/home/zkjaniko/ADAPT/ADAPT/server at Fri Jun 15 18:15:09 2018

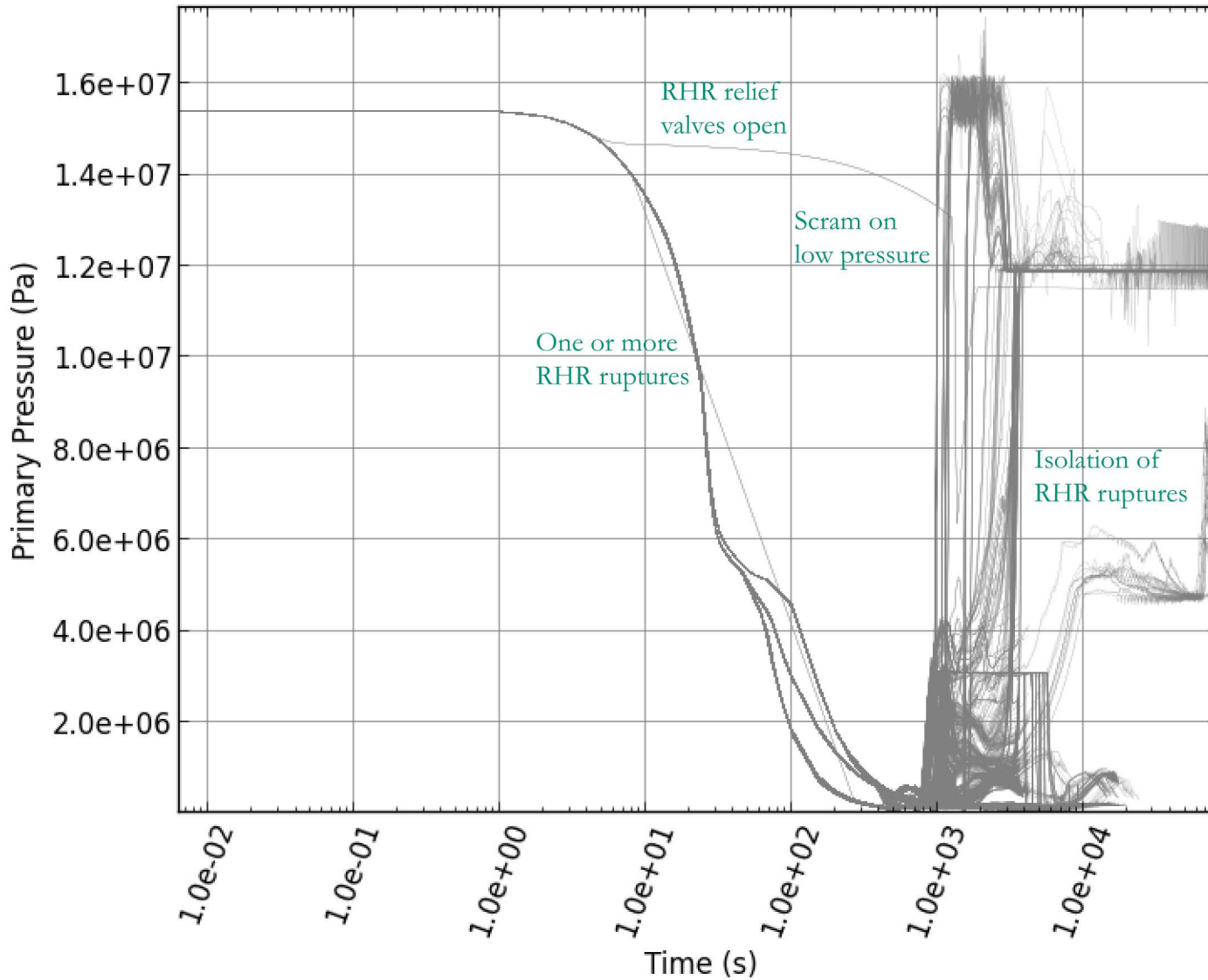

- This ISLOCA can outpace assumed PORV depressurization timing
 - 6 minutes after initiation

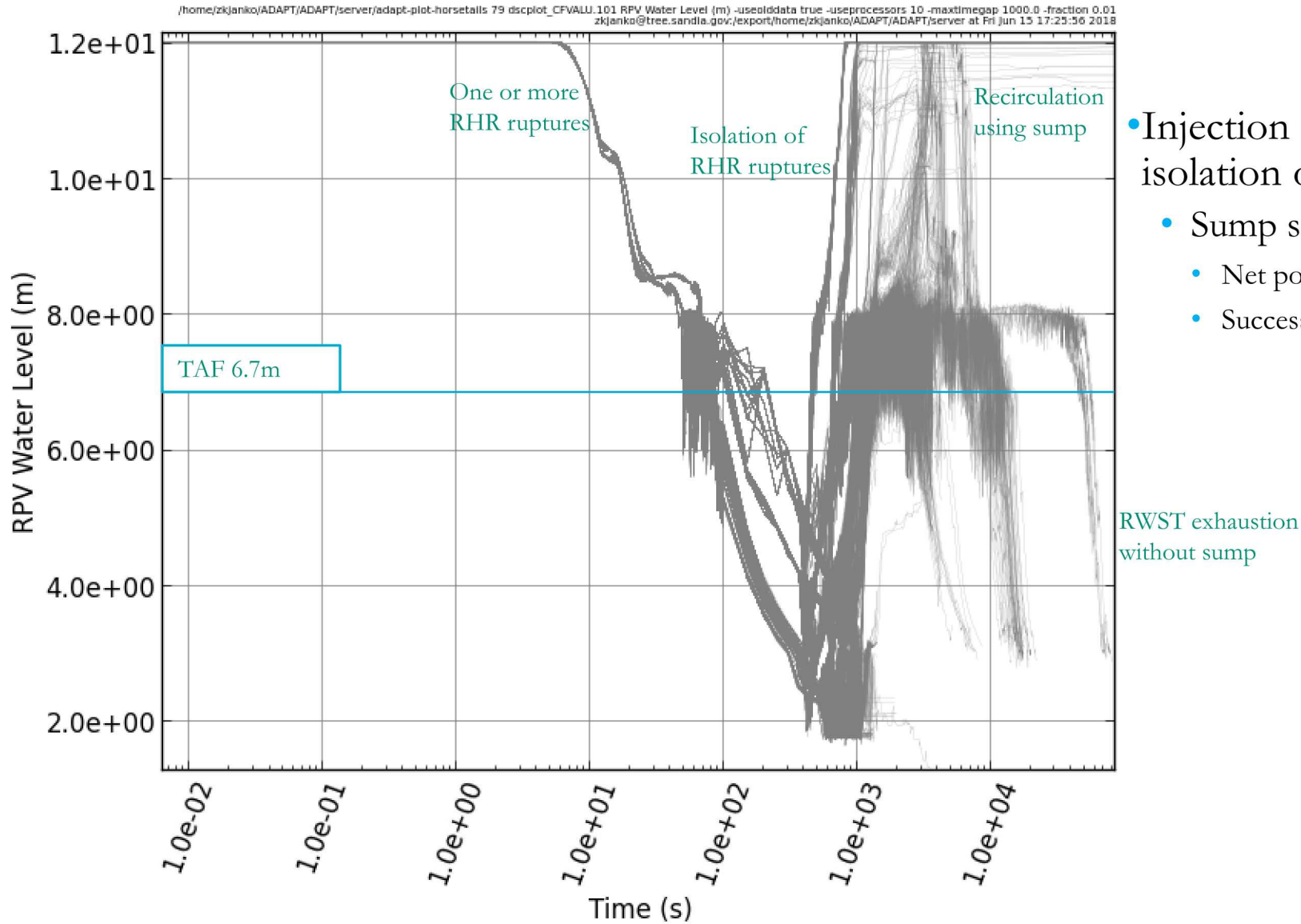

- Injection capability may be recovered through isolation of ruptures
 - Sump suction availability is not branched directly
 - Net positive suction head
 - Successful alignment of valves in RHR pump room

- Used dynamic importance measures (DYIs) to evaluate the impact of input parameters on output measures

Importance Measure	Description
$DYI1 = \frac{R(x=1)}{R(x=0)}$	Consequence ratio of occurrence to non-occurrence
$DYI2(i) = \frac{R(x=1_i)}{R(x=0)}$	Consequence ratio of occurrence value $x = 1_i$ to non-occurrence
$DYI3(i) = \frac{R(x=1_i)}{R(x=1)}$	Consequence ratio of occurrence value $x = 1_i$ to average of occurrence $x = 1$

Branching Parameter	Core Intact Fraction	Hydrogen Generation	Peak Containment Pressure	Environmental Cs Release Fraction
RHR HX Room Door Closed	1.0	0.99	1.0	1.2
RHR Pump Room Door Closed	1.0	3.2	1.0	11
RHR HX Tube Isolation	1.0	0.98	1.0	0.32
RHR HX Shell Isolation	1.0	0.69	1.0	0.56
RWST Isolation	1.0	0.097	1.0	0.074
PORV Blowdown	1.0	3.2	1.0	3.7

- Core damage is insensitive to these parameters
- Isolation activities have positive impact on some output measures
 - E.g., “When RHR HX shell isolation is successful, the expected value of the Cs environmental release fraction is 0.56 times its expected value when isolation fails.”
- RHR pump room door being closed leads to higher fuel oxidation and Cs release
 - Retains flood water and delays mitigating actions that restore safety injection
- PORV depressurization appears to have an undesired impact on fuel oxidation and Cs release

- Closer look at PORV depressurization

Consequence Measure	DYI Value
RPV Cs Release Fraction	4.0
Containment Building Cs Release Fraction	3.1
Auxiliary Building Cs Release Fraction	3.0
Peak Auxiliary Building Pressure	1.1
Final RCS Pressure	0.62

- Depressurization occurs too late to be helpful
 - Allows RCS to stay depressurized with low RPV level
 - Contributes to fuel oxidation and failure
- PORV depressurization mitigation action as implemented may not be appropriate for a large ISLOCA
 - Requires diagnosis of the size of the ISLOCA



- Mitigating action timing

Branching Condition	Value	Hydrogen Generation	Environmental Cs Release Fraction	Peak Containment Pressure
RHR HX Tube Isolation Timing	393.0 s	$1.0 * 10^{-4}$	$1.9 * 10^{-4}$	$2.1 * 10^{-3}$
	608.0 s	$1.3 * 10^{-2}$	$4.9 * 10^{-2}$	$6.4 * 10^4$
	1050.0 s	0.16	$8.4 * 10^{-2}$	$3.0 * 10^{-2}$
	10^{20} s	$4.6 * 10^9$	$1.4 * 10^{10}$	$2.6 * 10^{-4}$
RHR HX Shell Isolation Timing	393.0 s	$5.6 * 10^{-4}$	$2.3 * 10^{-19}$	$2.2 * 10^{-3}$
	608.0 s	$6.4 * 10^{-2}$	$2.9 * 10^{-3}$	$2.3 * 10^{-2}$
	1050.0 s	$6.9 * 10^{-2}$	$5.4 * 10^{-2}$	$3.2 * 10^{-2}$
	10^{20} s	$1.2 * 10^{10}$	$4.4 * 10^{10}$	$2.4 * 10^{10}$

- 10^{20} s represents failure
- Greater sensitivity for lowest-middle time transition than for middle-high transition
 - If action cannot be completed in short time, may be advantageous to focus on other actions



- Recent modifications to *ADAPT* allow for quantitative comparison of input parameters for impact on output measures from multiple codes
 - Which physical parameters are most impactful?
 - How does human interaction timing affect the outcome?
- PWR RHR ISLOCA insights
 - Fast diagnosis and decision on operator actions may significantly alter outcome
 - Minutes, not hours
 - PORV depressurization may not be appropriate
 - Plant maintenance may significantly affect outcomes
 - Doors and drains in auxiliary building are important to flood water drainage