



## Hydrogen Stations for Urban Sites

---

PI/Presenter: Brian Ehrhart

Gabriela Bran-Anleu, Ethan Hecht, Chris LaFleur, Alice Muna,  
Ethan Sena, Carl Rivkin (NREL), Joe Pratt

Sandia National Laboratories

Safety Codes and Standards Tech Team Meeting

August 9, 2018

SAND2018-XXXX

This presentation does not contain any proprietary, confidential, or otherwise restricted information

Sandia National Laboratories is a multi-mission laboratory managed and operated by National Technology and Engineering Solutions of Sandia, LLC., a wholly owned subsidiary of Honeywell International, Inc., for the U.S. Department of Energy's National Nuclear Security Administration under contract DE-NA0003525.

## Station Size and Detail Increased



H2USA Hydrogen Fueling Station Working group identified station footprint reduction for urban areas as the *#1 priority* for the FY17 H2FIRST projects

- Analyzing larger station sizes
  - 300 kg/day, 2 hoses to 600 kg/day, 4 hoses
- Level of detail increased
  - Setback distances required by NFPA 2 based on both tube pressure and size

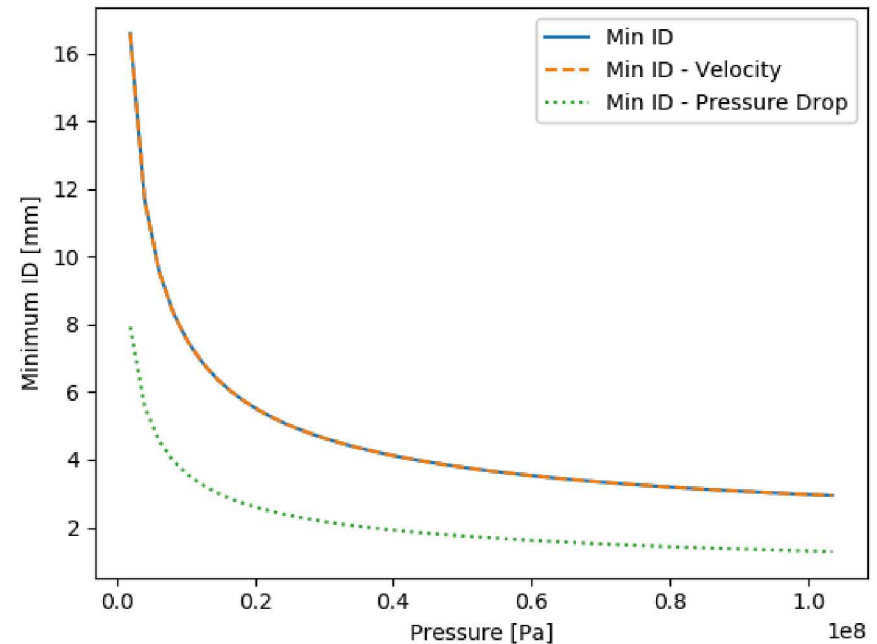

*Larger and more detailed system description reveals previously unexplored code requirements*

# Specified Similar Component Needs for Three Hydrogen Sources

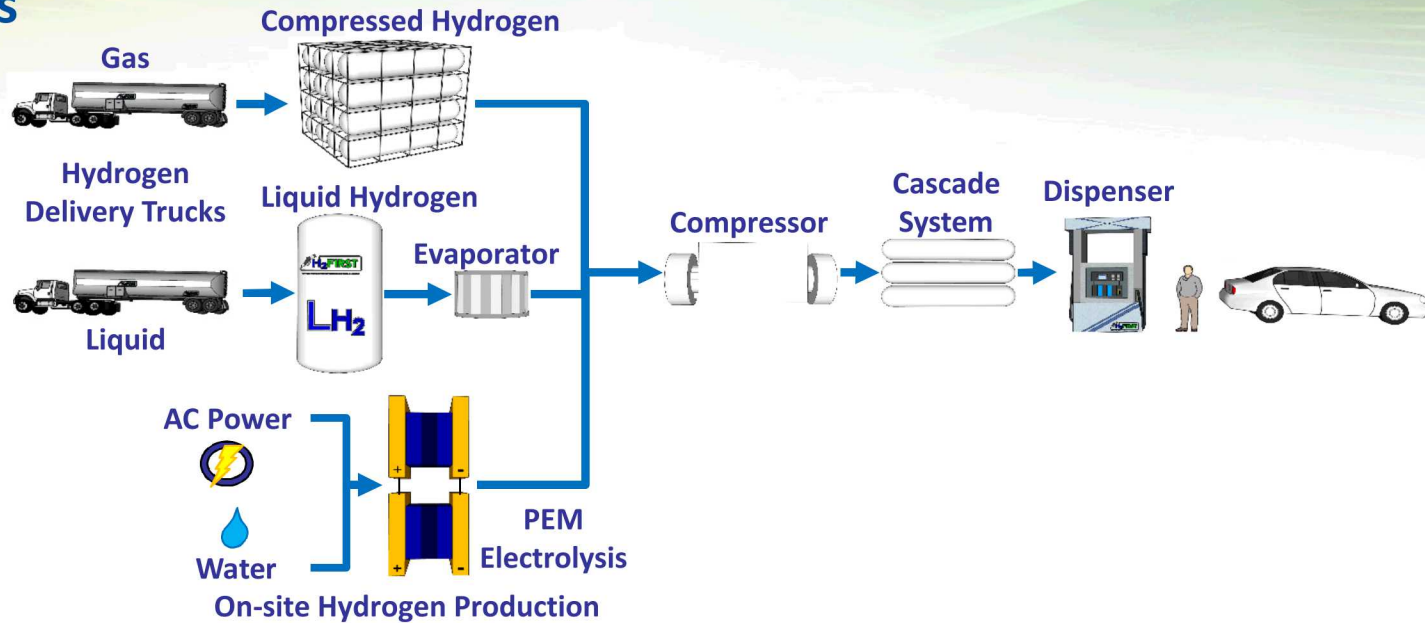

- Compressor
  - 25 kg/hr flow rate (constant 600 kg/day)
  - Outlet pressure of 94.4 MPa (13,688 psi)
- Chillers
  - 25.2 kW (7.2 tons) of refrigeration needed for each chiller
  - Aluminum cooling block of 1,330 kg (0.49 m<sup>3</sup>) needed for each
- Cascade
  - 10 cascade units, each containing 5 (1:1:3) pressure vessels
  - Outlet flow rate 40 kg/hr to each dispenser
- Dispensing
  - 4 fueling positions, 70 MPa, -40°C

# Detailed Design for Delivered Gas Base Case

## Bulk Gas Storage

- 800 kg bulk storage (pre-compressor)  
33% over daily design capacity
- Max pressure of 50 MPa (7,250 psi)
- Multiple cylinders in ISO-sized superstructure
- Connecting tubing: 25 kg/hr at minimum pressure 6.9 MPa (1,000 psi) yields minimum ID 9.1 mm

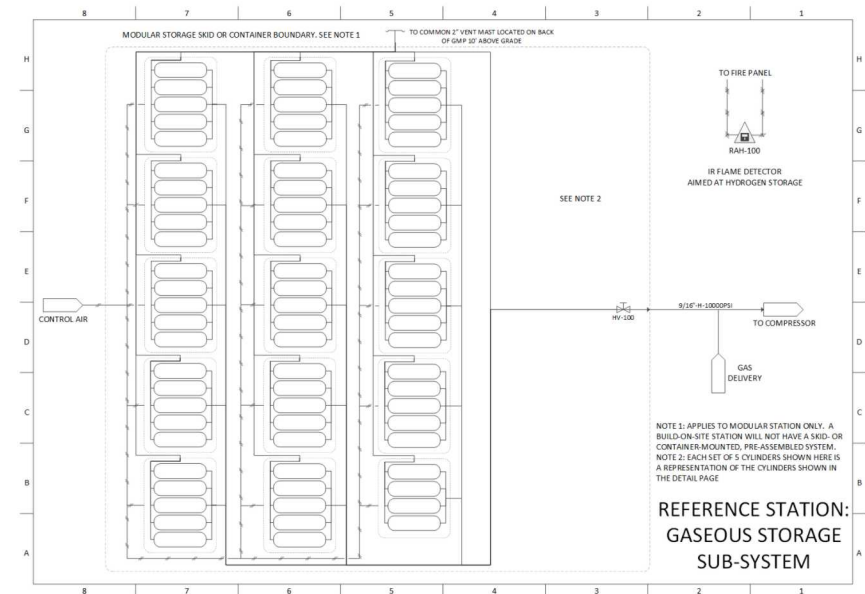

# Minimum Footprint/Full Layouts for Base Case Delivered Gas

- Minimum Footprint
  - Hydrogen system only

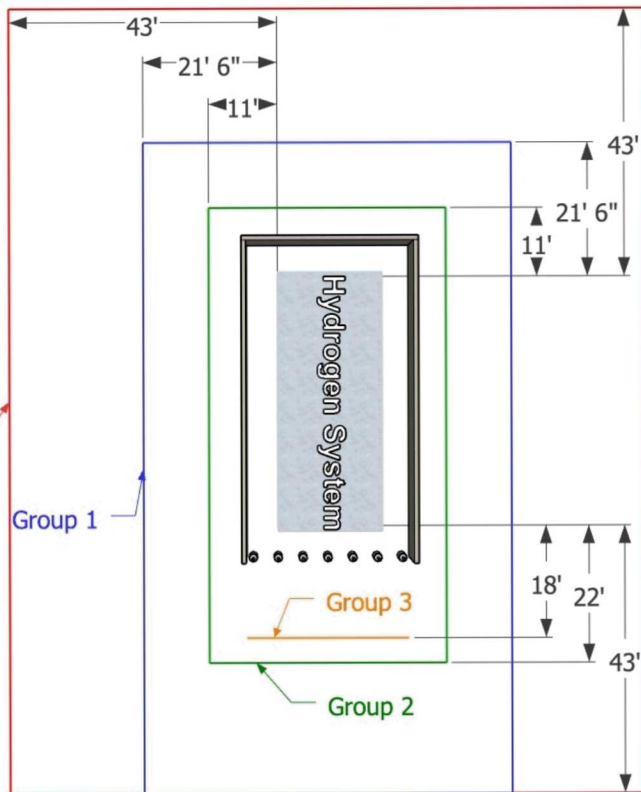

- Full Layout
  - Convenience store
  - Parking
  - Traffic flow
  - Delivery



*Non-hydrogen station components have large effect on final station layout*

# Base Case Gas: Truck Path

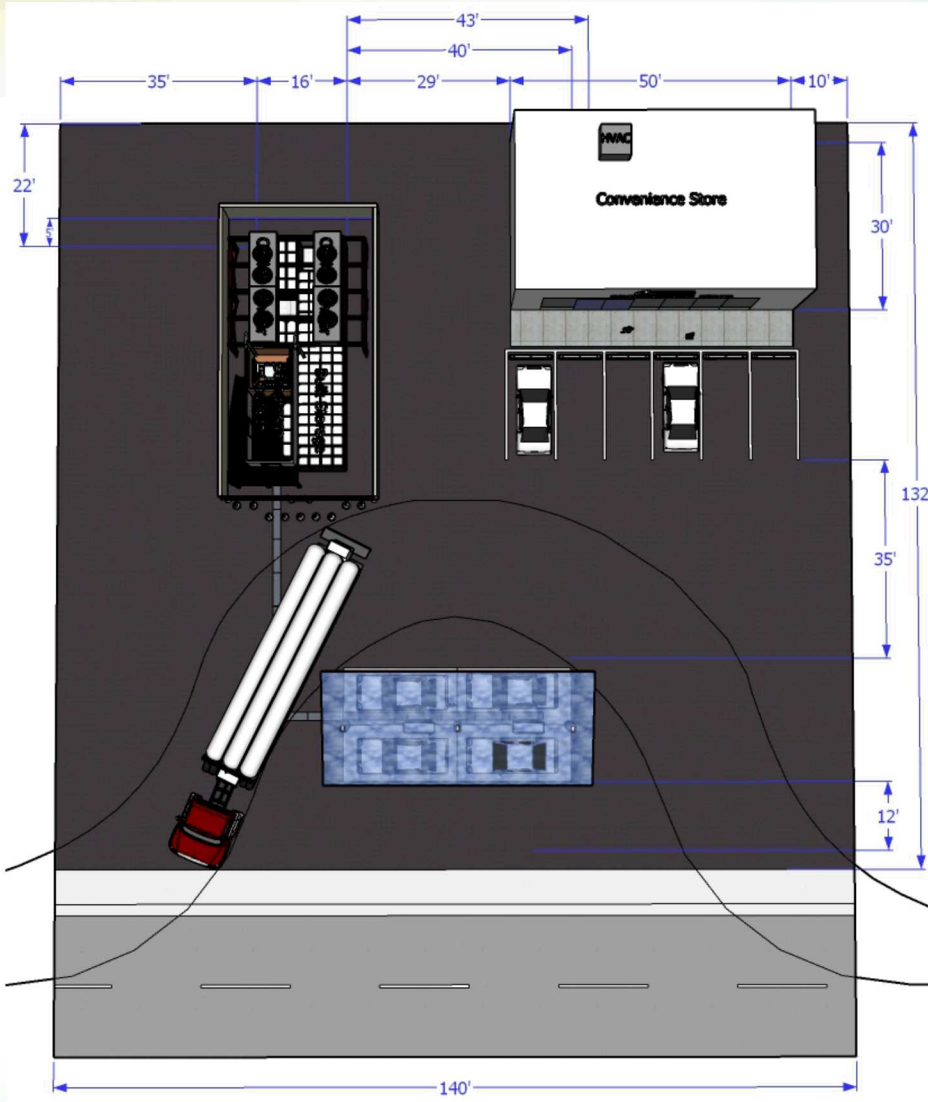

- Lot size 140' by 132'
- Total Area: 18,480 ft<sup>2</sup>

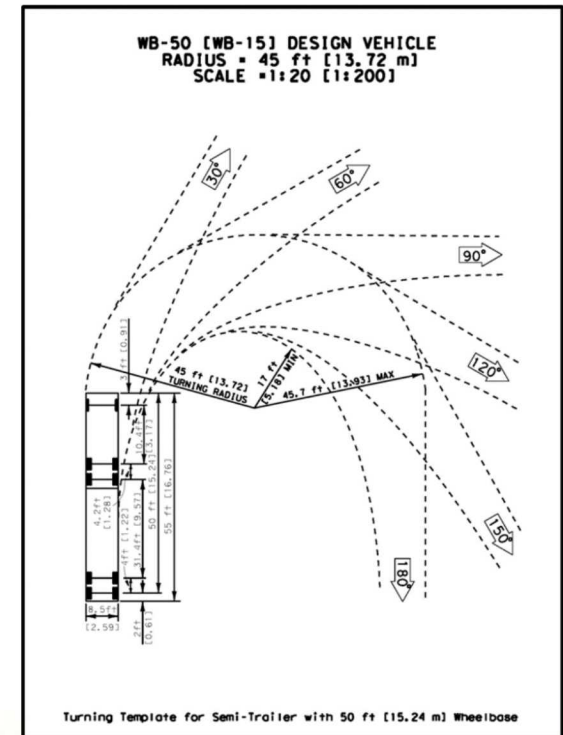

## Approach: Footprint and Hazard Comparisons to Base Cases

- Comparisons to base cases:
  - New code requirements
  - New delivery methods
  - Gasoline refueling station co-location
  - Underground storage
  - Roof-top storage
  - Performance-based designs
- Compare risk/consequence for specified hazard scenarios
  - Design calculations use HRSAM <sup>1</sup>
  - Risk and consequence calculations use HyRAM <sup>2</sup>

*Quantification of absolute risk is difficult; comparisons show trends*

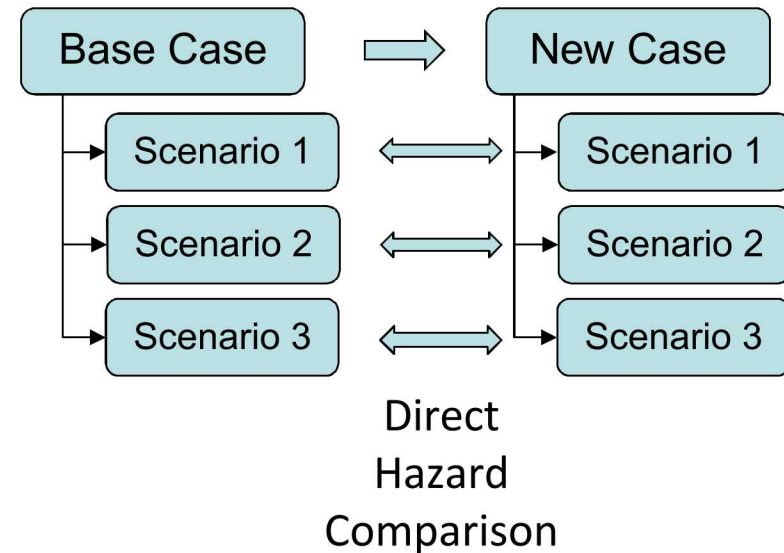

<sup>1</sup> <https://hdsam.es.anl.gov/index.php?content=hdsam>

<sup>2</sup> <http://hyram.sandia.gov/>

# Hazard Scenarios from NFPA 2 Chapter 5

Scenario	Fueling Station Scenario
Fire	H <sub>2</sub> fire resulting from a leak at the H <sub>2</sub> dispenser
Pressure Vessel Burst	Compressed gas storage
Deflagration	A H <sub>2</sub> deflagration within compressor enclosure
Detonation	Localized H <sub>2</sub> /air mixture in vent pipe
Unauthorized Release	Release of H <sub>2</sub> from storage vessel
Exposure Fire	Unrelated vehicle fire at the lot line
External Event	Seismic event where largest pipe bursts
Protection System Out of Service	H <sub>2</sub> discharge where the interlock fails
Emergency Exit Blocked	H <sub>2</sub> system outdoors
Fire Suppression Out of Service	H <sub>2</sub> system outdoors

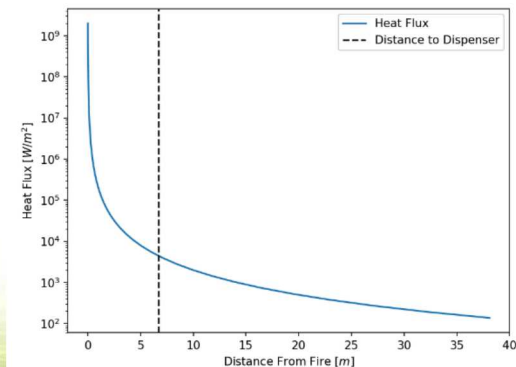
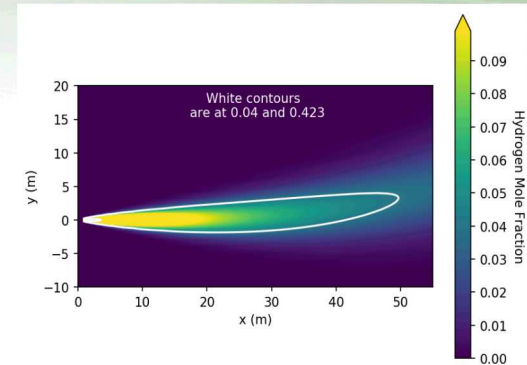

*Hazard analysis results for base cases will be compared to other cases*

## Some Base Case Gas Scenarios Get Qualitative Treatment

Scenario	Fueling Station Scenario	Result
<b>Pressure Vessel Burst</b>	Compressed gas storage	Mitigations listed for stationary pressure vessels
<b>Detonation</b>	Localized H <sub>2</sub> /air mixture in vent pipe	Vent pipe L:D ratio is present
<b>Protection System Out of Service</b>	H <sub>2</sub> discharge where the interlock fails	No additional risk scenarios because interlocks not credited above
<b>Emergency Exit Blocked</b>	H <sub>2</sub> system outdoors	Not applicable
<b>Fire Suppression Out of Service</b>	H <sub>2</sub> system outdoors	Not applicable

# Some Hazard Scenarios Analyzed via Quantitative Risk Assessment

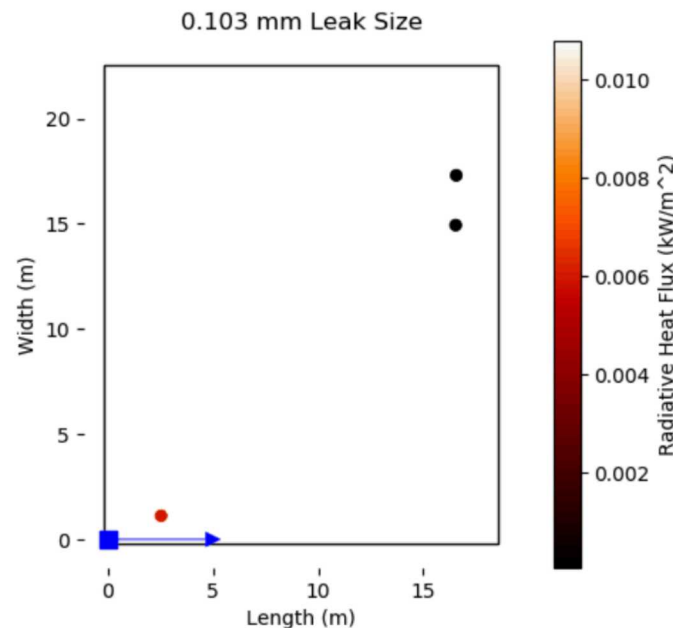
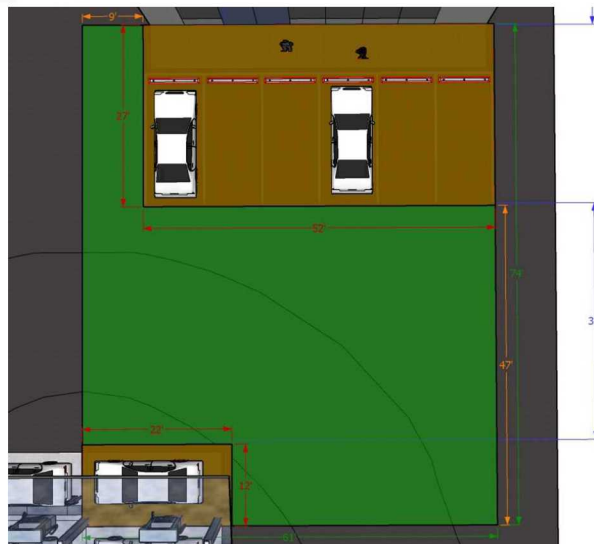

Scenario	Fueling Station Scenario	Base Case Gas Result
Fire	H <sub>2</sub> fire resulting from a leak at the H <sub>2</sub> dispenser	Average Individual Risk (AIR) = $2.241 \times 10^{-6}$ fatalities/year
External Event	Seismic event where largest pipe bursts	AIR = $2.151 \times 10^{-2}$ fatalities per year, conditional on earthquake

# Consequence Analysis Used for Other Scenarios

Scenario	Fueling Station Scenario	Base Case Gas Result
<b>Deflagration</b>	A H <sub>2</sub> deflagration within compressor enclosure	$3.89 \times 10^5$ Pa overpressure for 1% pipe size leak
<b>Unauthorized Release</b>	Release of H <sub>2</sub> from storage vessel	Hypoxia met within 4 m of the release point
<b>Exposure Fire</b>	Unrelated vehicle fire at the lot line	Heat flux on dispenser: 4.4 kW/m <sup>2</sup>

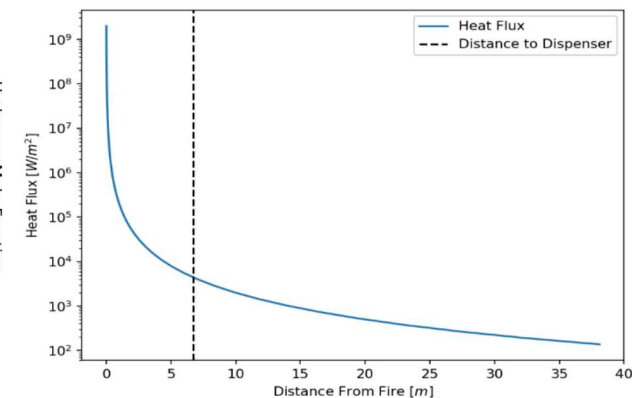
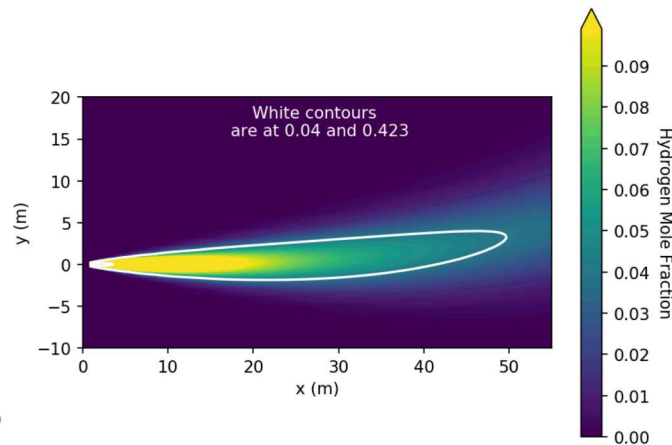
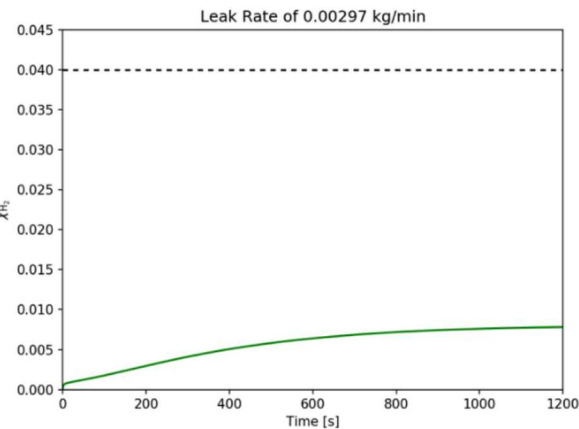

## Design and Hazard Analysis for Delivered Liquid Base Case

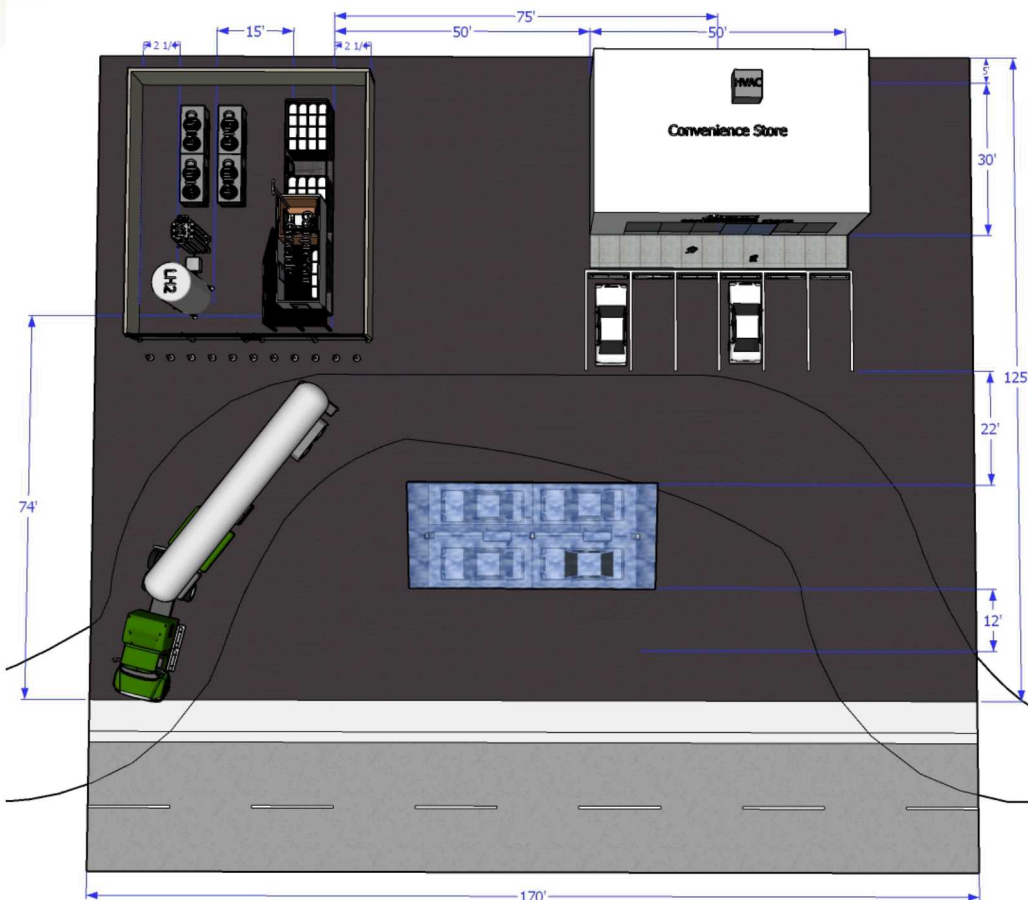

- Bulk liquid storage
  - 800 kg, 11,299 L (2,985 gal)
- Lot size 170' by 125'
- Total Area: 21,250 ft<sup>2</sup>

Two hazard scenarios different than BCG

- Release of hydrogen from storage tank
  - Hypoxia and temperature criteria met within 5 m and 10 m of release, respectively
- Seismic event where a pipe bursts
  - AIR =  $4.1 \times 10^{-4}$  fatalities/year, conditional
  - Instead of  $2.1 \times 10^{-2}$  fatalities/year, conditional

*Hazard analysis results for base case will be compared to other cases*

# Detailed Design and Hazard Analysis for On-Site Electrolysis

## Base Case

- PEM electrolyzer (nominal 2 MW)
  - Approximate footprint 40 ft + 20 ft container
- GH<sub>2</sub> low pressure storage (gas reservoir)
  - Supplies 15 kg of GH<sub>2</sub> at 20 bar to compressor
- No delivery truck
- Hazard analysis: only some scenarios different than gas
  - Deflagration to consider electrolyzer enclosure as well as compressor enclosure
  - External Event
    - Seismic event where largest pipe bursts
    - Largest pipe is in the electrolyzer container

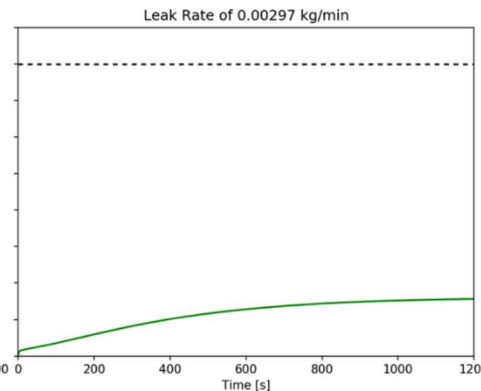
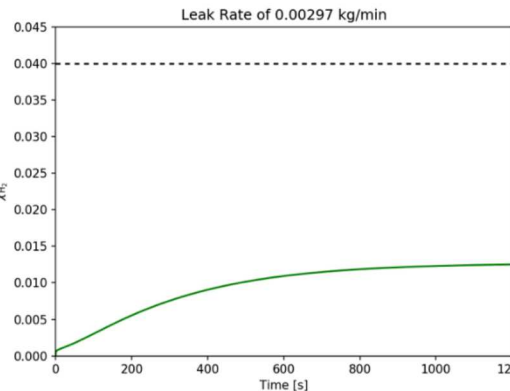
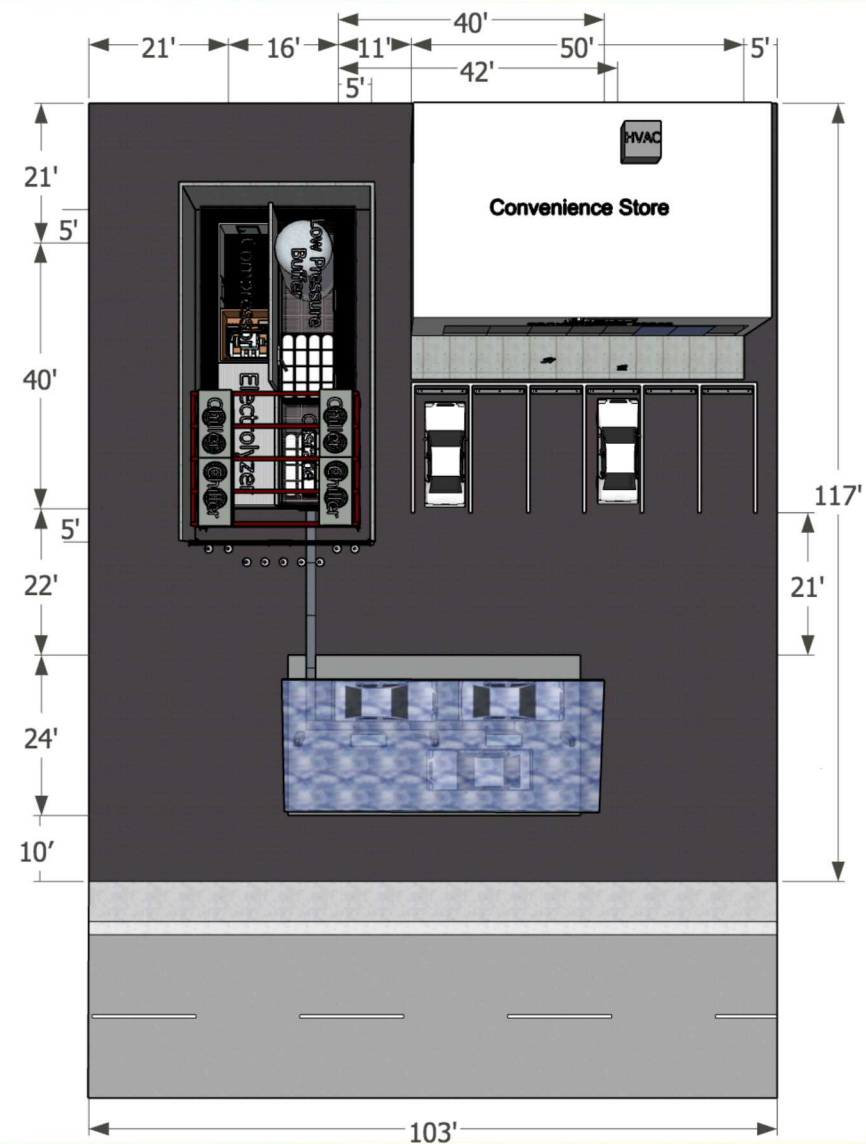

## Code Issues Identified

- Gaseous setback distances
  - Large system can have “bulk storage” before and after compressor
- Multiple approaches possible:
  - Single system could take worst-case: maximum pressure from one area and maximum ID from other area
  - Could also calculate setback distances for each system section and select largest
- Liquid setback distances
  - Hybrid system (liquid-to-gas) analyzed as all-liquid system
    - *Recently changed in 2020 Ed. of NFPA 55*
  - Setback distances are different for most exposures, only a few able to be reduced

*Calculations for larger system may lead to unintended setback distances*

Group	Exposure	Reducible	Distance
1	1 Lot lines	*	15 m (50 ft)
1	2 Air intakes		23 m (75 ft)
1	3 Operable openings in buildings		23 m (75 ft)
1	4 Ignition sources		15 m (50 ft)
2	5 Places of public assembly		23 m (75 ft)
2	6 Parked cars		1.7 m (25 ft)
3	7(a)(1) Sprinklered non-combustible building	*	1.5 m (5 ft)
3	7(a)(2)(i) Unsprinklered, without fire-rated wall	*	15 m (50 ft)
3	7(a)(2)(ii) Unsprinklered, with fire-rated wall	*	1.5 m (5 ft)
3	7(b)(1) Sprinklered combustible building	*	15 m (50 ft)
3	7(b)(2) Unsprinklered combustible building	*	23 m (75 ft)
3	8 Flammable gas systems (other than H2)	*	23 m (75 ft)
3	9 Between stationary LH2 containers		1.5 m (5 ft)
3	10 All classes of flammable and combustible liquids	*	23 m (75 ft)
3	11 Hazardous material storage including LO2	*	23 m (75 ft)
3	12 Heavy timber, coal	*	23 m (75 ft)
3	13 Wall openings		15 m (50 ft)
3	14 Inlet to underground sewers		1.5 m (5 ft)
3	15a Utilities overhead: public transit electric wire		15 m (50 ft)
3	15b Utilities overhead: other overhead electric wire		7.5 m (25 ft)
3	15c Utilities overhead: hazardous material piping		4.6 m (15 ft)
3	16 Flammable gas metering and regulating stations		4.6 m (15 ft)

# Effects of Future Changes to 2020 Edition NFPA 55/2 on Gas System

- Next edition of NFPA 2 code under review
- Example calculation of setback distances

	Group 1	Group 2	Group 3
<b>Current</b>	13 m (43 ft)	7 m (22 ft)	5 m (18 ft)
<b>Proposed</b>	8 m (25 ft)	6 m (19 ft)	5 m (17 ft)

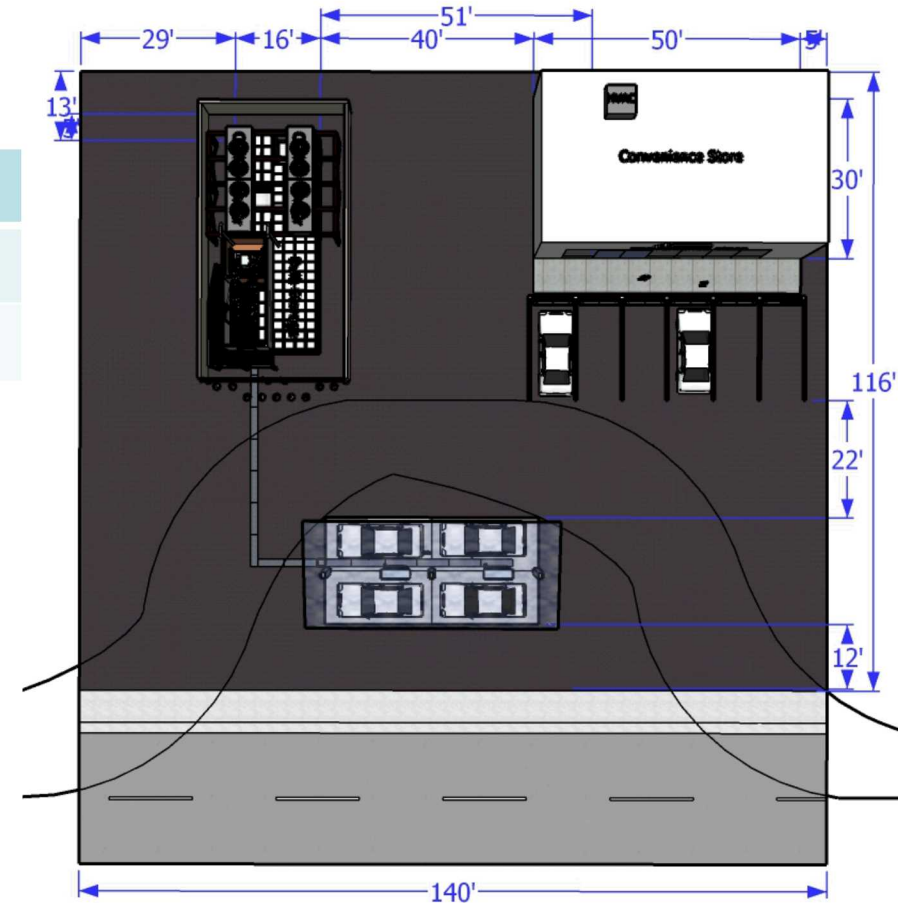
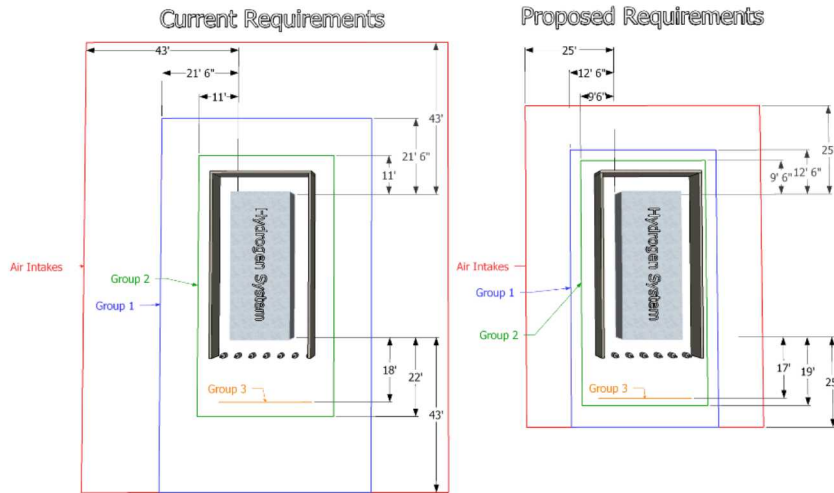

*Significant impact on minimum footprint, but other factors reduce impact on full layout*

# Different Delivery Methods Considered

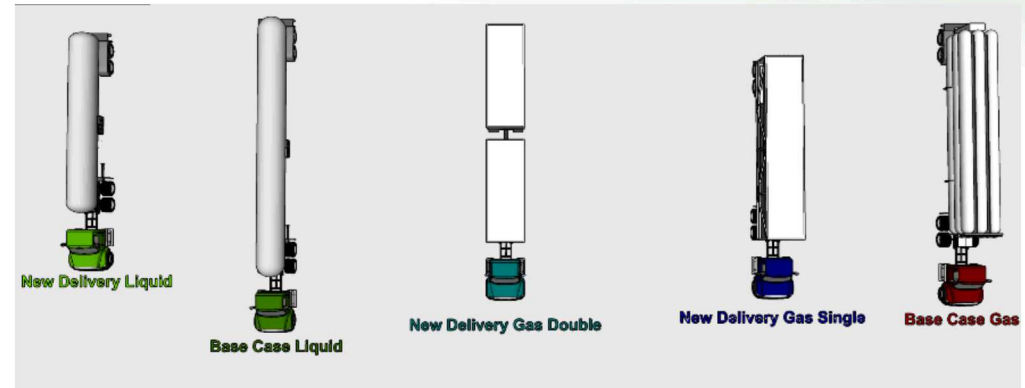
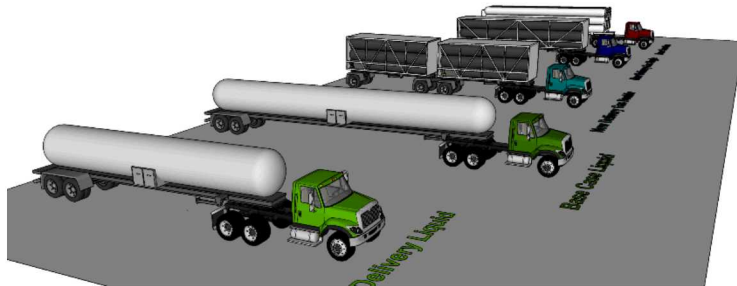

Delivery truck specifics will depend on local market conditions and supplier availability

	Delivered Gas		Delivered Liquid	
	Base Case	New Delivery	Base Case	New Delivery
<b>Hydrogen Pressure</b>	25 MPa (3626 psi)	50 MPa (7,252 psi)	--	
<b>Hydrogen Capacity</b>	300 kg	1,200 kg	3,000 kg	1,800 kg
<b>Truck-Trailer Length</b>	16.76 m (55 ft)	13.72 m (45 ft)	19.8 m (65 ft)	13.7 m (45 ft)

*Delivery very localized, but can still have major impact on station design*

## New Delivery Gas: Smaller Truck Reduces Footprint

- Truck trailer approximately 40 ft. instead of 55 feet
  - Increased capacity
- Lot size 125' by 132'
  - Base case 140' x 132'
- Total Area: 16,500 ft<sup>2</sup>
  - Base case 18,480 ft<sup>2</sup>

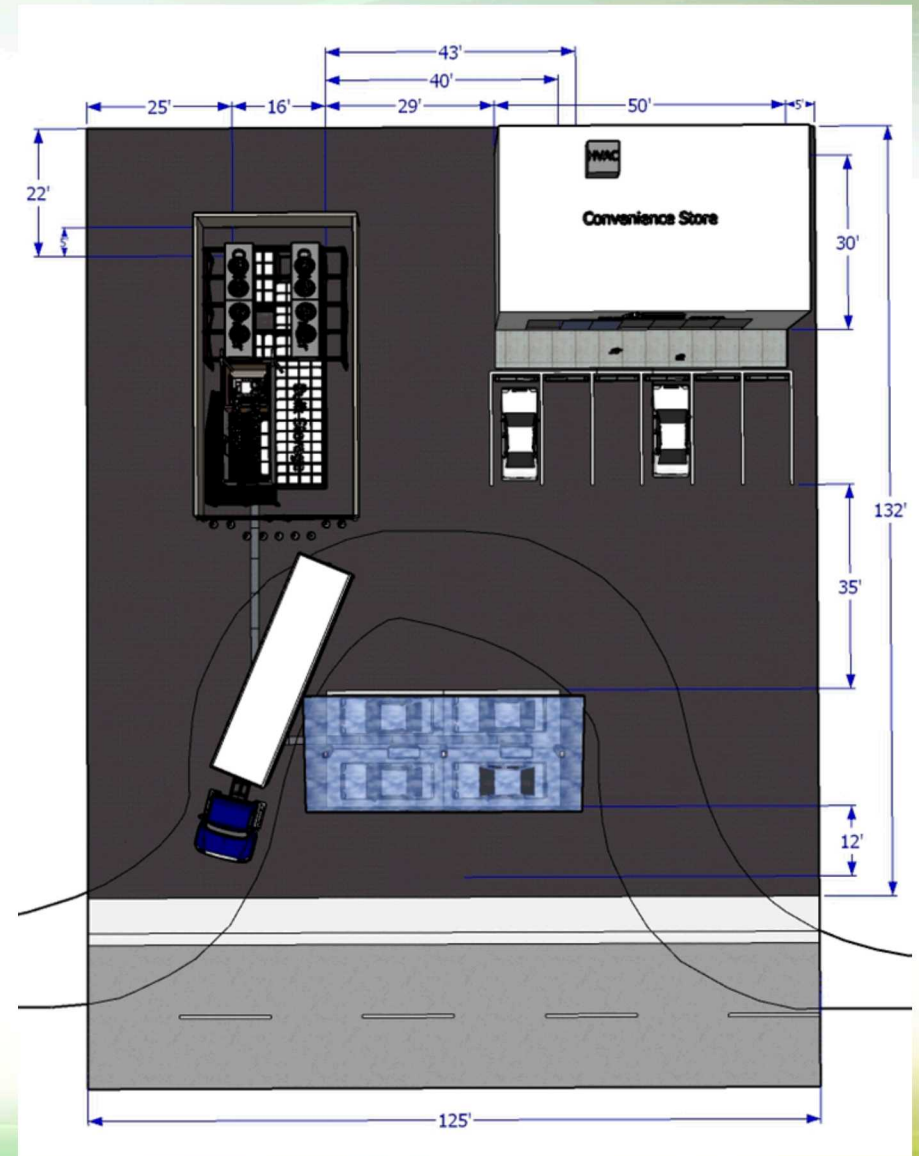

## New Delivery Liquid: Smaller Truck Reduces Footprint

- Truck trailer approximately 40 ft instead of 65 ft
  - Still sufficient capacity
- Lot size 145 ft by 120 ft
  - Base case 170 ft x 125 ft
- Total Area: 17,400 ft<sup>2</sup>
  - Base case 21,250 ft<sup>2</sup>

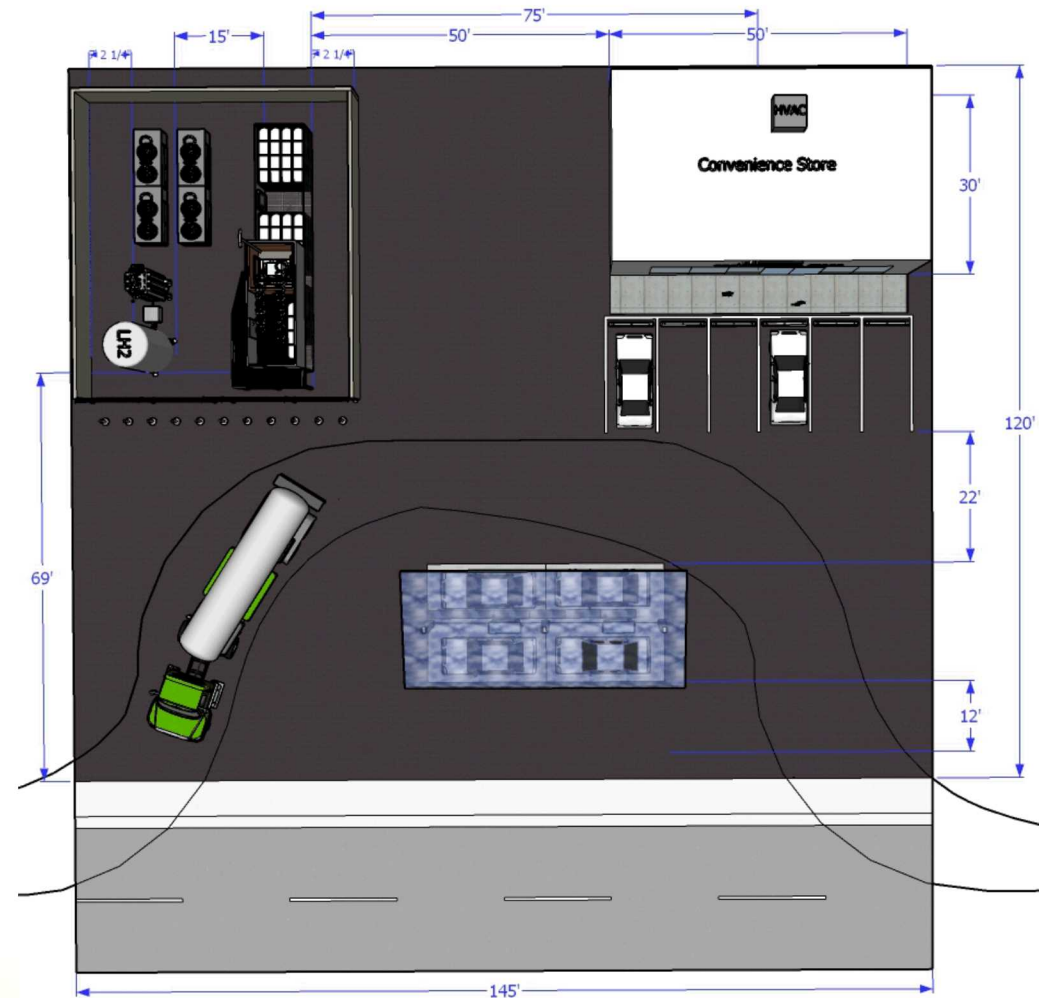

## Summary of Footprints of Different Designs

	Design	Footprint (ft <sup>2</sup> )	Reduction from Base Case
Gas	Base Case	18,480	--
	New Delivery	16,500	10.7%
	New NFPA	16,240	12.1%
Liquid	Base Case	21,250	--
	New Delivery	17,400	18.1%
Electrolysis	Base Case	12,051	--

- H2FIRST itself is a **SNL-NREL** co-led, collaborative project and members of both labs contributed heavily to this project.
- To be as relevant and useful as possible, the project integrates input and feedback from many stakeholders, such as:

- H2USA's Hydrogen Fueling Station Working Group 

- California Fuel Cell Partnership

- California Energy Commission

- California Air Resources Board

- UC Berkeley 

- Argonne National Lab 

- H2 Logic 



- Hydrogenics 

- ITM Power 

- Linde 

- Nuvera 

- PDC Machines 

- Proton OnSite 

- Siemens AG 

- FirstElement 

## Remaining barriers and challenges:

- General footprint difficult to apply to nationwide siting study
  - Site-specific considerations difficult to account for
- Code requirements difficult to interpret
  - Could lead to different interpretations by different AHJs
  - More pronounced differences in interpretation for performance-based designs
- Underground and aboveground storage much more site-specific
  - Underground utilities or structures could prevent burial of storage
  - Jurisdiction-specific height restrictions could limit roof-top storage

## Future work:

- Underground and roof-top storage analysis
  - Quantify footprint reduction
  - Identify other possible methods for further reduction
- Performance-based designs
  - Smaller than NFPA 2 setbacks, but equivalent or lesser risk
  - Typically site-specific, but can identify general trends
  - Could help inform future code changes
- Economic evaluation
  - Based on previous reference stations
  - Will consider economic impact of different footprint reductions
- National siting study for reduced footprint
  - Can quantify effect of varying footprint size
- Host workshop with stakeholders to present results and outline future needs

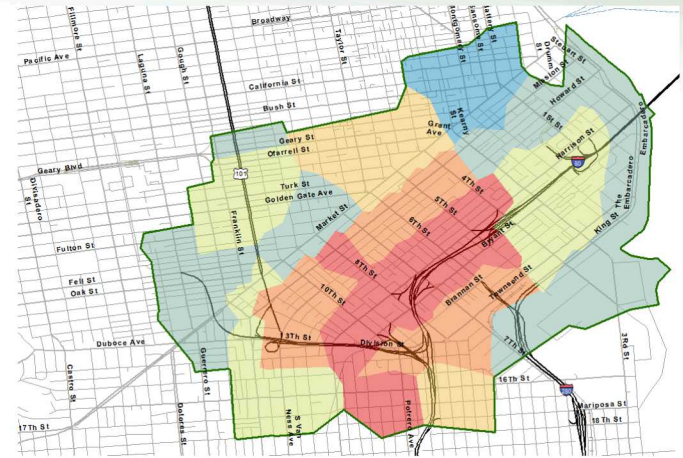

**Preferred location of stations in San Francisco**



Any proposed future work is subject to change based on funding levels



## Hydrogen Fueling Stations for Urban Sites – Workshop

- **Hosted by Sandia National Laboratories and the National Renewable Energy Laboratory**
- **Location:** Sandia National Laboratories, Livermore, CA
- **Date:** Thursday, September 6, 2018
- **Time:** 9:30 AM – 5:30 PM (PDT)
- **RSVP Required**
- *Participants will:*
  - *Discuss how NFPA 2 is/can/should be used to site stations*
  - *Learn about various footprint-reducing methods*
  - *Learn to use/interpret results from the Hydrogen Risk Assessment Models (HyRAM) software*
  - *Give feedback to the team to make sure results are relevant and consistent with real-world station siting*
  - *Take a lab tour to learn how measurements are taken to study the behavior of cryogenic hydrogen*
  - *Visit a nearby hydrogen refueling station to see real-world application*

- **Relevance:**
  - Create compact hydrogen reference station designs appropriate for urban locations, enabled by hazard/harm mitigations, near-term technology improvements, and/or risk-informed (performance-based) layout designs
- **Approach:**
  - Direct comparison of hazards/risks for base cases vs. alternative layouts with reduced footprints
- **Accomplishments and Progress:**
  - Completed base case designs and hazard analysis for delivered gas, delivered liquid, and on-site electrolysis
  - Identified upcoming code changes, alternate delivery assumptions, gasoline co-location
- **Future Work:**
  - Underground and roof-top storage analysis
  - Performance-based designs
  - Economic evaluation
  - Siting study for reduced footprint
  - Host workshop

# TECHNICAL BACK-UP SLIDES

## Timeline

- Task start date: March 2017
- Task end date: September 2018

## Budget

- FY17 DOE Funding: \$920k
  - SNL: \$870k
  - NREL: \$50k
- Planned FY18 DOE Funding: \$125k
  - SNL: \$100k
  - NREL: \$25k

## Barriers (Delivery)

- A. Lack of Hydrogen/Carrier and Infrastructure Options Analysis
- I. Other Fueling Site/Terminal Operations
- K. Safety, Codes and Standards, Permitting

## Partners

- NREL

- H2USA Hydrogen Fueling Station Working group identified station footprint reduction for urban areas as the *#1 priority* for the FY17 H2FIRST projects
- Objective:
  - Create compact gaseous and delivered liquid hydrogen reference station designs appropriate for urban locations, enabled by hazard/harm mitigations, near-term technology improvements, and/or risk-informed (performance-based) layout designs

Barrier from Delivery MYRDD	Impact
A. Lack of Hydrogen/Carrier and Infrastructure Options Analysis	Provide assessment of station footprint possibilities using current technologies and show possibilities for urban siting
I. Other Fueling Site/Terminal Operations	Show how to reduce station footprint within or equivalent to current requirements
K. Safety, Codes and Standards, Permitting	Identify main drivers of station footprint and requirements that do not contribute to reduced risk

# Compressor, Cascade, and Dispenser P&IDs

