

Versatile Monitoring Platform

Ben Shiller¹ • Bashiri Smith²

Texas A&M University College Station¹ • St. Thomas University of the Virgin Islands²

Project Mentor: Dr. David Novick



Problem Statement

The Versatile Monitoring Platform (VMP) is a series of network computers (Actors) which communicate with actuators and sensors. Data and commands are passed between the Actors and a principal computer (Director) which collects the data and, when necessary, conducts high level control across all the Actors. It is written entirely in Python.

The platform will provide autonomous control over sensors and actuators, secure file transfer, a proper database interface, remote storage and, most importantly, security to the system – all within a user-friendly, easy-to-program interface.

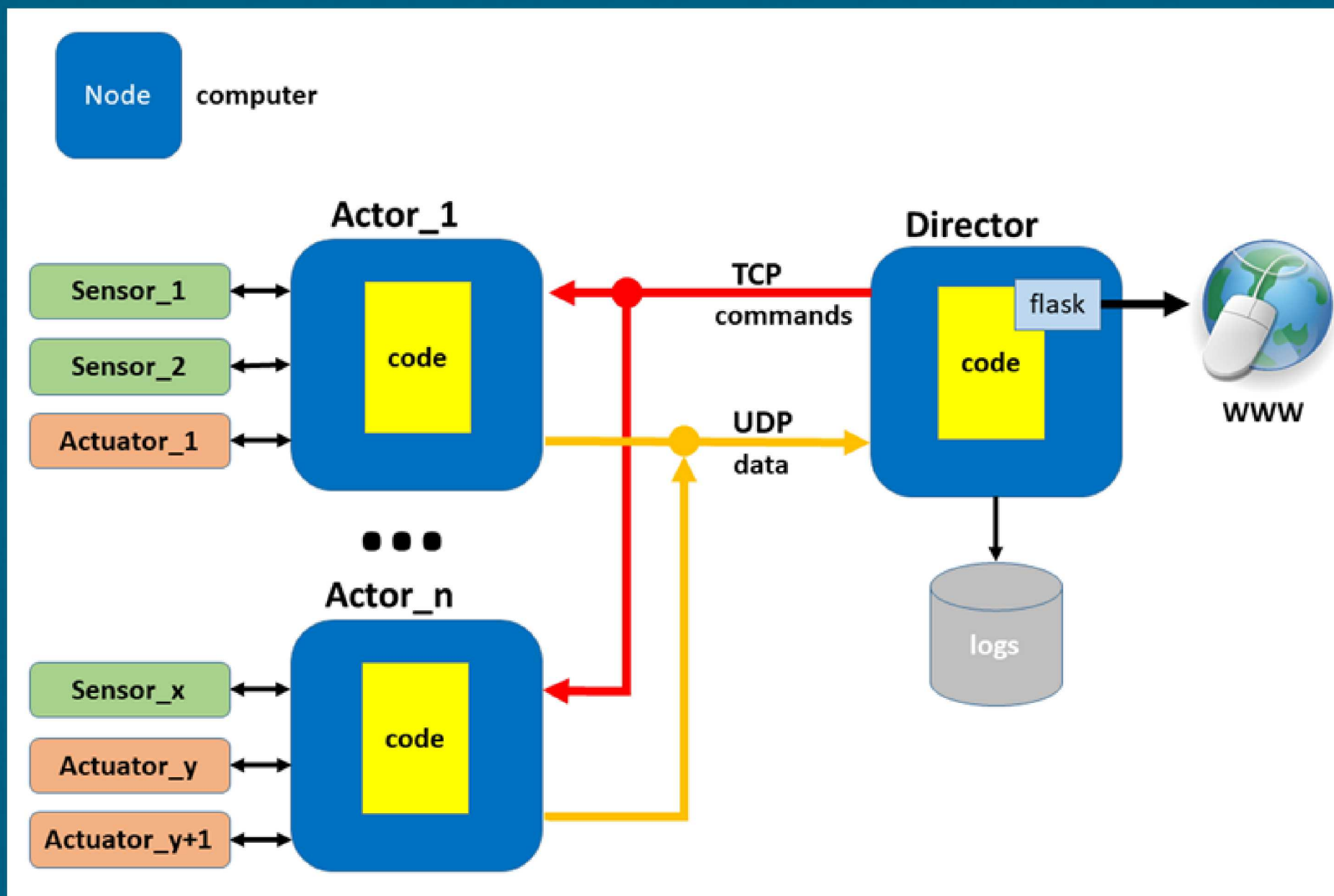

Objectives and Approach

VMP is designed to be integrated through a web interface by users with little to no experience with computer science - enabling any authorized operator to dynamically observe collected data and regulate physical phenomenon received from the Actors. The project is divided into four processes: File Transfer, Database, Web Services, and Security.

- File Transfer
 - SFTP (SSH File Transfer Protocol) is implemented using the Paramiko Python package.
- Database
 - A SQLite database is used to log messages between devices.
- Web Services
 - Uses HTTPS
 - User-friendly for easy configuration and observation.
 - Files are transferred to and from a cloud service via SFTP.
- Security
 - Security is a desideratum in all processes.
 - TLS (Transport Layer Security) is utilized for TCP messages between devices.
 - The Cryptography python module is incorporated to use symmetric encryption over UDP sockets.

Results

- Increased data transfer efficiency – Using secure file transfer and database storage
- Improved user experience – Better user interface, easier to program desired behaviors
- Locked down security – Increased its resistance to hacking and tampering

Impact and Benefits

- For partners
 - Using a well-established language such as Python with numerous modules allows the easy integration of various features such as file transfer, database, and security.
 - Reduction in cost over the current system allows the VMP to be used by more end users.
- For Sandia
 - Educational resource for new hires and interns
 - Development of networked, distributed control systems
 - File and database management with the “cloud”