

Overview of NSTec Los Alamos Imaging/Detector Characterization

Duane Smalley, Stuart Baker,
David Phillips, Dane Morgan, Kristina Brown,
Jesus Castaneda, Dave Schwellenbach,
Wendi Dreesen, Andrew Smith, Andrew Corredor,
Al Meidinger, Carl Carlson

This work was done by National Security Technologies, LLC, under Contract No. DE-AC52-06NA25946 with the U.S. Department of Energy.



Nevada National Security Site

Managed and Operated by National Security Technologies, LLC



Outline

- Radiographic Support Capabilities at Los Alamos Operations
 - X-ray sources
 - Variable energy 2 MeV electron accelerator
 - Platts flash x-ray source, ~300 keV 50 ns pulse x-ray source
 - CW 225 keV confined x-ray source
 - Scintillator testing
 - Examine scintillator performance from local test
 - Test developmental scintillators
 - Camera evaluation
 - Provide systematic evaluations of camera performance
 - Radiography analysis
 - Battle-hardened analysis/processing software has been developed by the team
 - Simulation development



Radiographic Chain

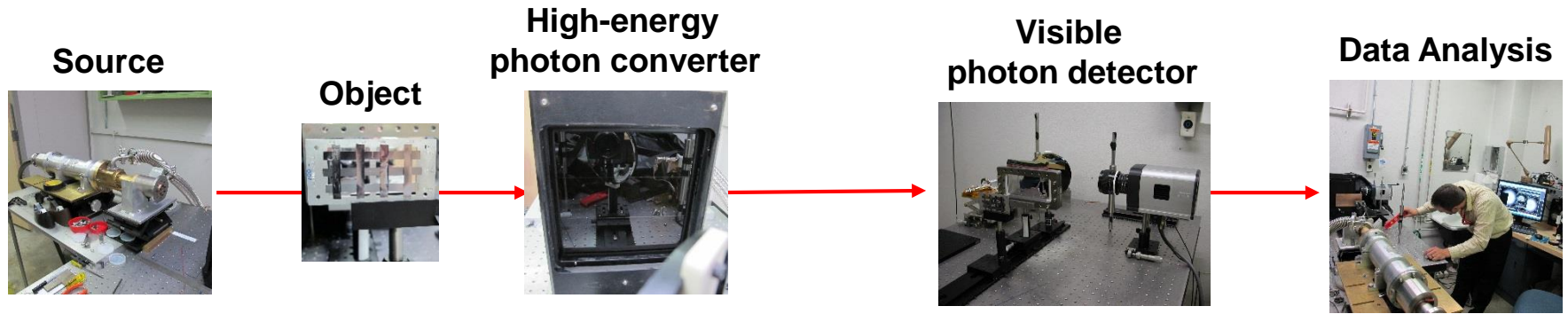

- End-point Energy
 - Higher end-point energies have better resolving power of denser objects
 - Lower end-point provides high-contrast of low-density object
- Intensity
 - High intensity gives better SNR
- Multi-pulse
 - Can acquire multiple time images
- Spot Size
 - Smaller spot size provides better resolution

- Due to high-energy, high intensity beam imaging require a scintillator
- Resolution
 - Limited by source size and radiation scatter and not scintillator
- Brightness
 - Material dependent
- High density
 - Greater ability to convert high-energy photons
- Decay time
 - $T < 100$ ns for pulsed machines

- High quantum efficiency
- Large collection area
- Low readout noise

- Overworked
- Takes work home
- Finds boring images amazing



Sources: Platts Source

- Low end-point energy
 - ~300 keV
- 35 mR @ 1 m
- Single-pulse or multi-pulse configurations
- Spot size of ~1.5 mm
- Red Sage development work
- X-ray diffraction



flat field corrected, rotated Basket Weave 3 mm LYSO

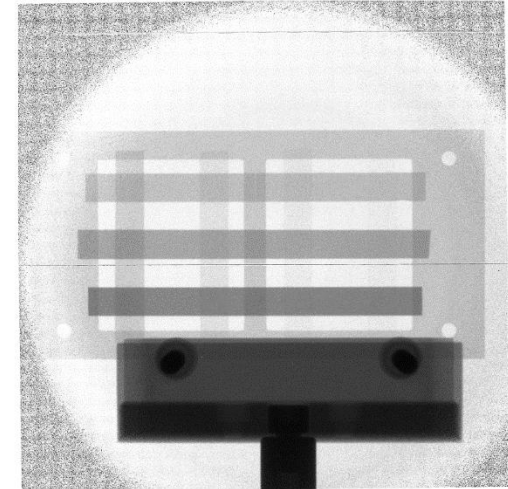

Lul Edge

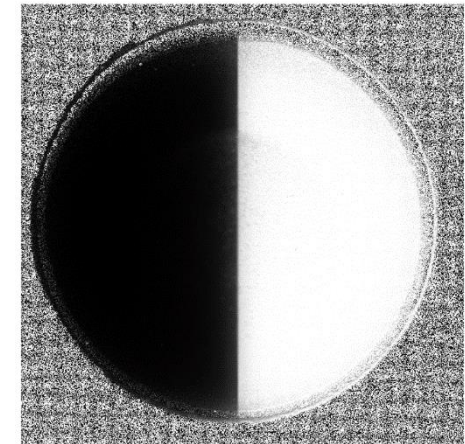

Sources: e⁻ Linac, injected beam

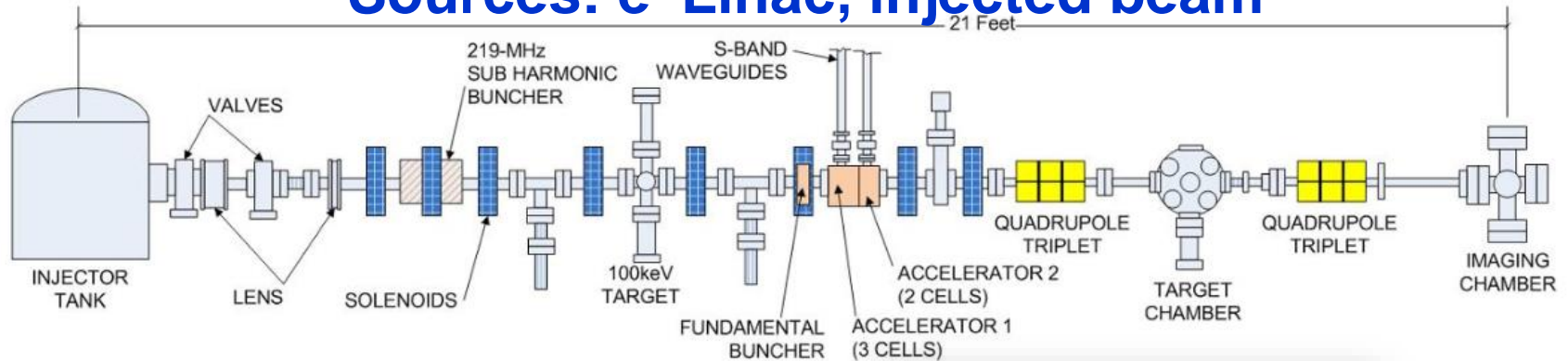

- Beam current: 6 A peak
- Energy range: 10–100 keV
- Variable pulse width, 250 ps to 4 μ s
- Rep rate single shot: 100 Hz
- Based on Santa Barbara LINAC (Idaho State)

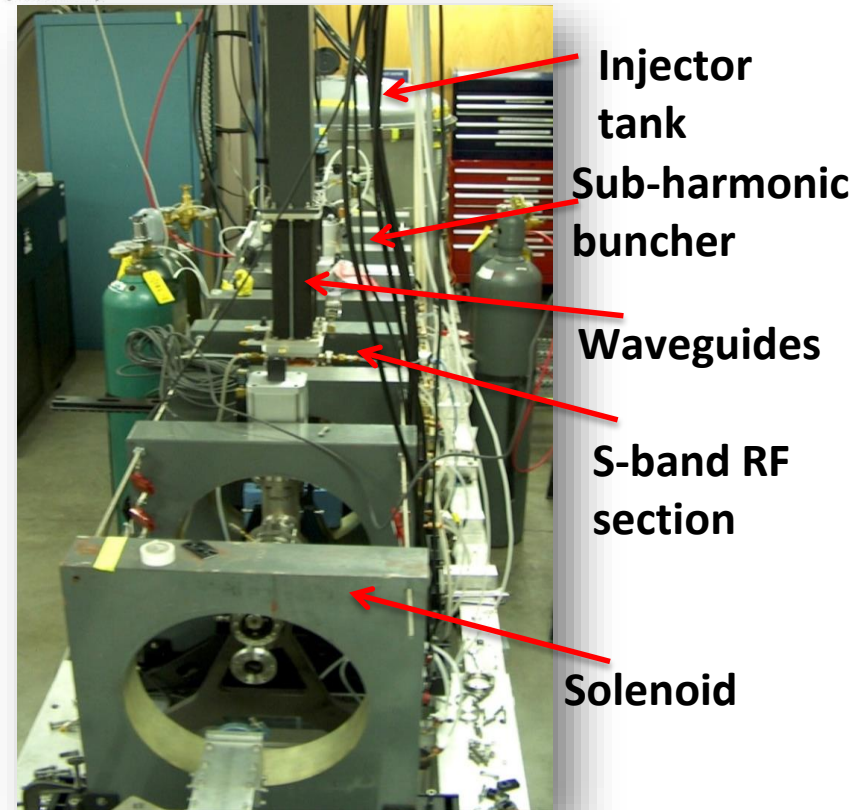

Sources: e⁻ Linac, accelerated beam

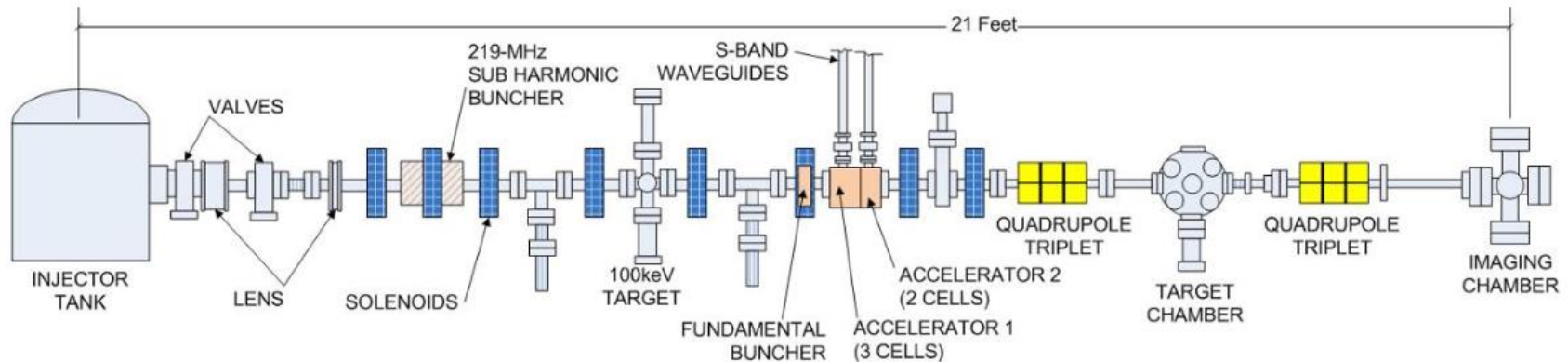

- Accelerated peak current of ~0.5 A
- S-band microstructure
 - Calculated 30 ps pulse width with 350 ps separation
- Calculated energy range from 250 keV to 2.5 MeV
- New spectrometer to be installed, beam optics to be optimized
- MHz modulation being pursued

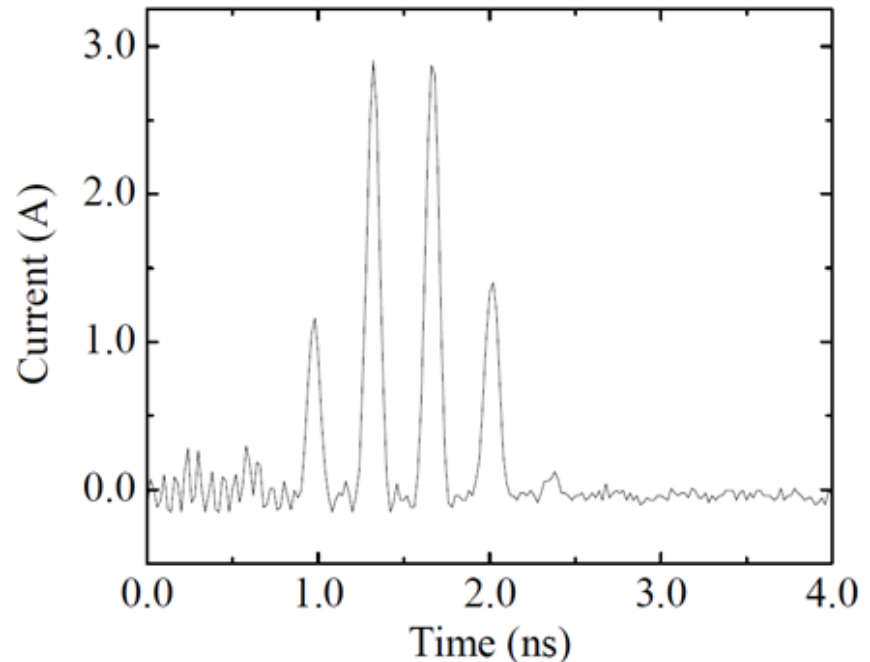

Sources: Comet MXR-225 keV VF

- Tunable energy up to 225 keV continuous source
- 600–1600 W power
- Small, adjustable spot size
- Easily acquired cheap precision data for evaluating basic scintillator performance

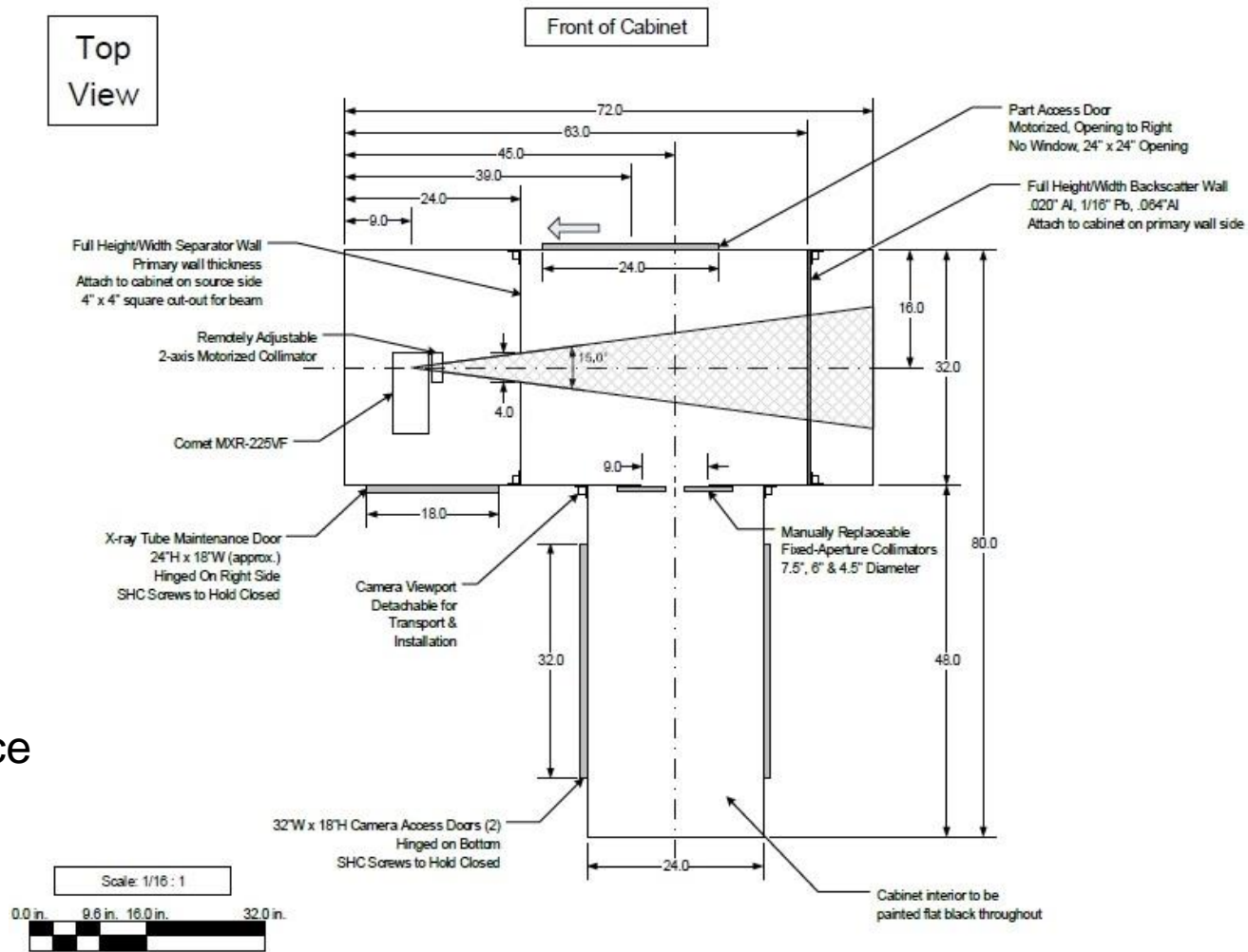

Scintillator Testing



- Examine currently used LYSO scintillators
- Determine performance of new materials

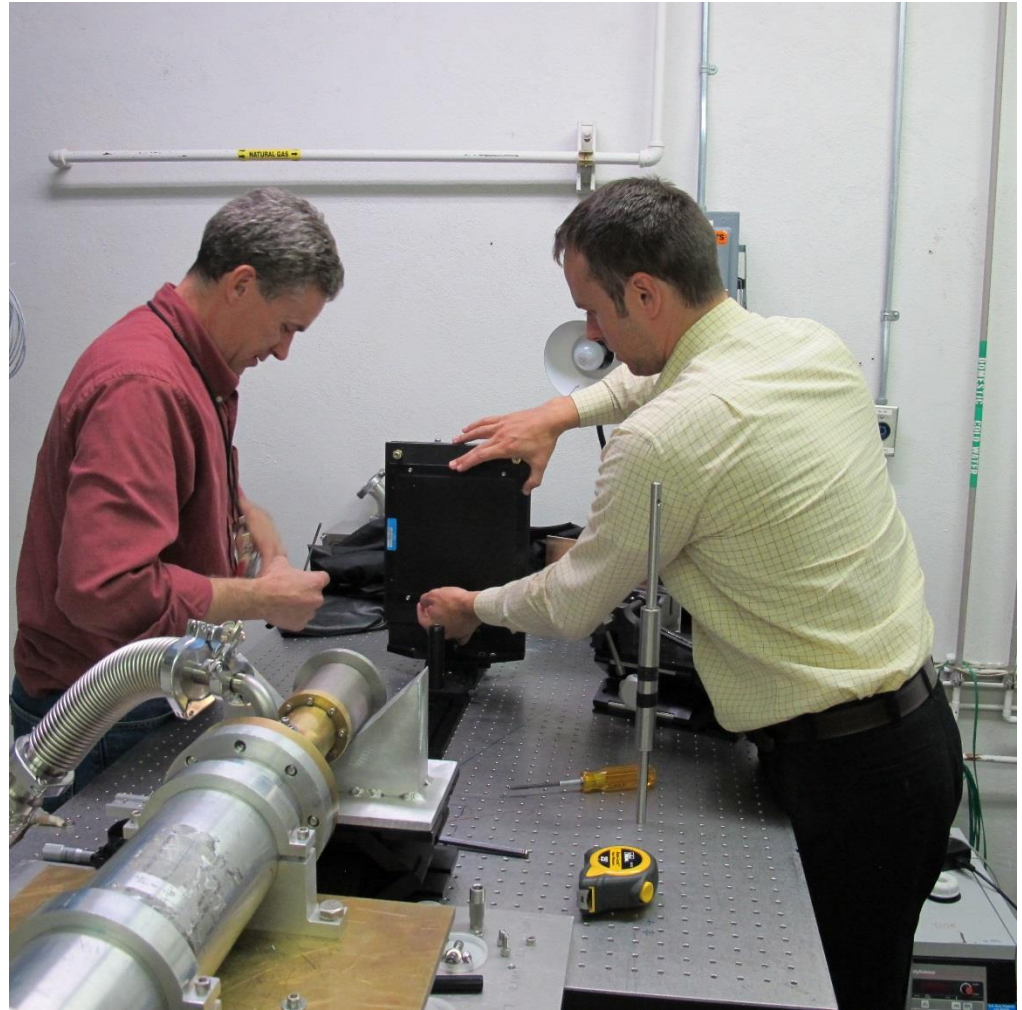

Scintillator Testing

Scintillator	$\rho(\frac{g}{cm^3})$	$\tau (ns)$	$\frac{photons}{MeV}$	Peak emission (nm)	Size (mm)	Max Thickness (on hand)
GLO	9.1	~ms	55,000	610	165 × 165	2 mm
Lul	5.6	~40	100,000	550	45 mm diameter	200 μ m
LYSO	7.1	42	32,000	420	200 × 66	10 mm
Csl	4.5	980	65,000	550	200 × 200	600 μ m

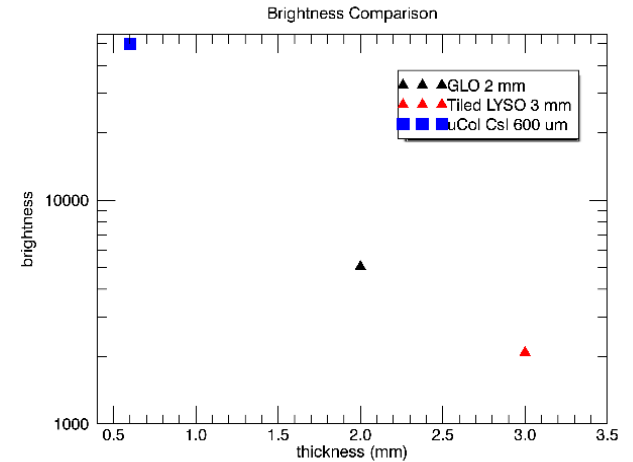
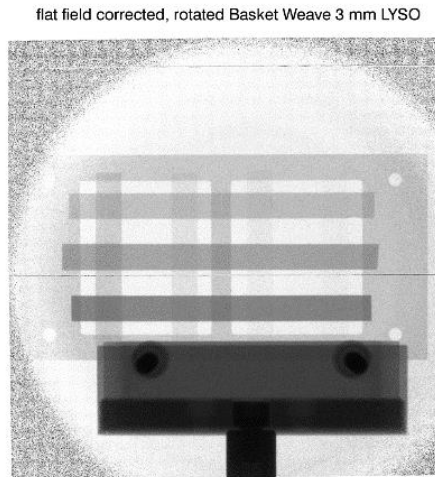
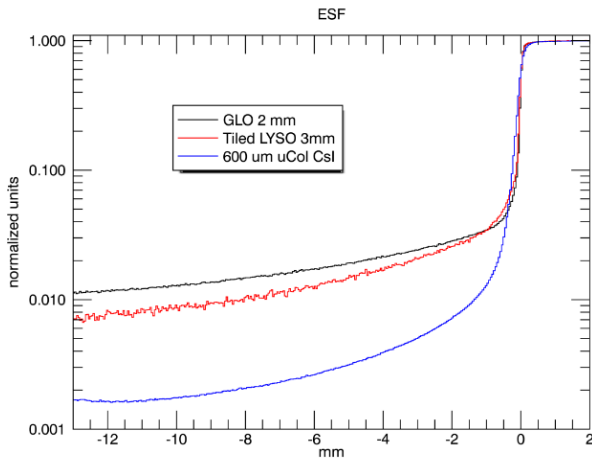

Camera Development/Evaluation

- Provide systematic evaluation of camera performance
- Light-tight camera evaluation box
- Development of digital framing camera
- Radiometric measurements of sensor performance

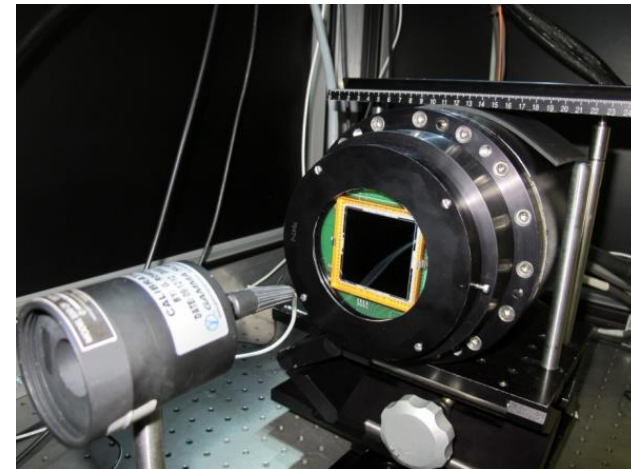
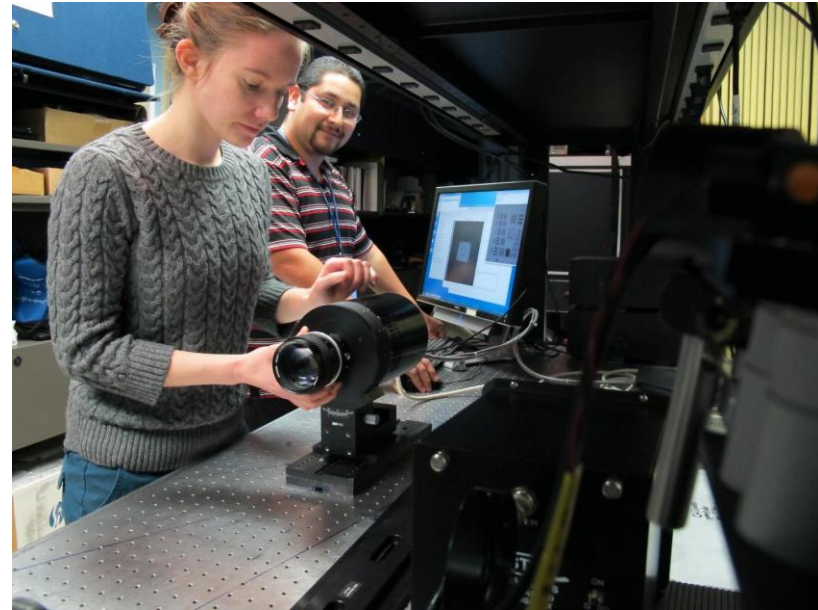

Camera Development/Evaluation

- Produce easily repeatable, low uncertainty transfer curves
- Determine signal-to-noise ratio of camera system with high precision
- Provide sensor dynamic range
- Provide baseline performance for single- or multi-frame cameras

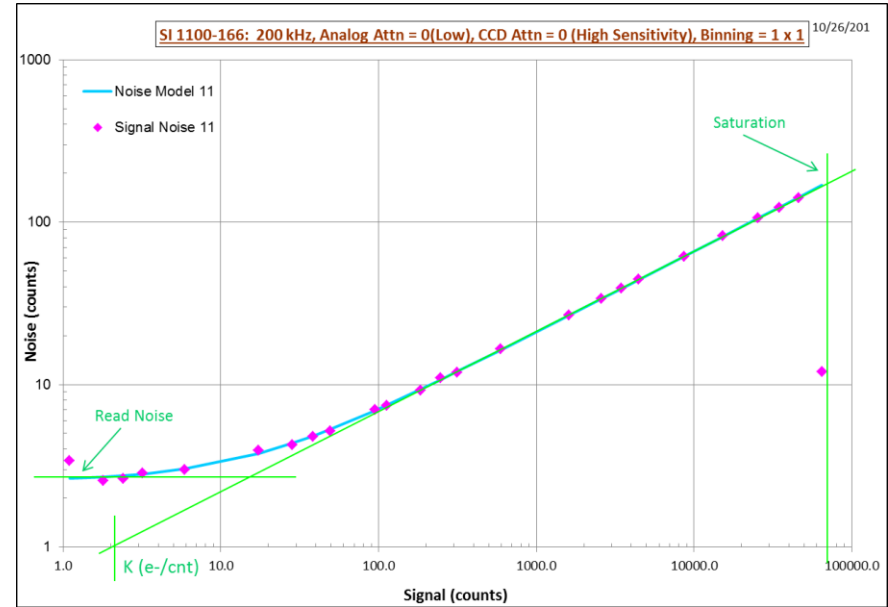

Camera Signal to Noise ratio

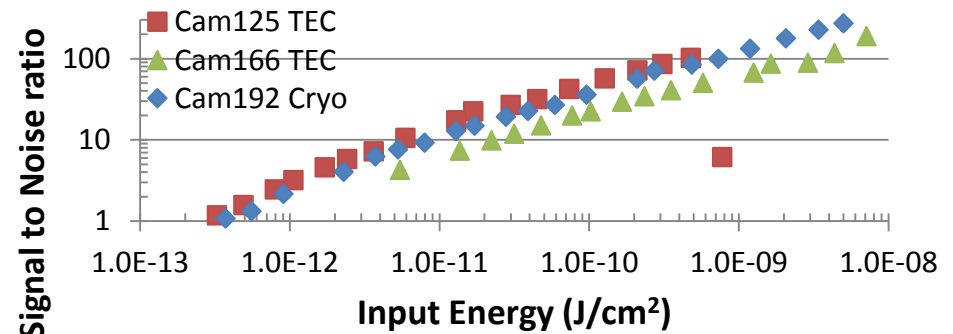

Data Analysis: Source Simulations

- Lacked current monitors on the Platts x-ray head
- Had to take a guess at spectrum
 - Assumed the end-point was 300 keV in a steady state voltage
- Modeled cathode and anode with GEANT4
 - Lacks electric field, currently shows cathode interaction that is not really there
- Propagate spectrum through experimental configuration

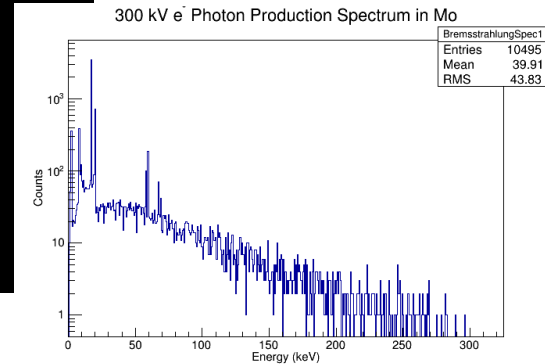
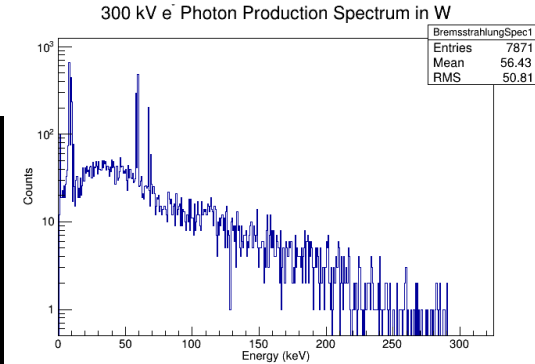
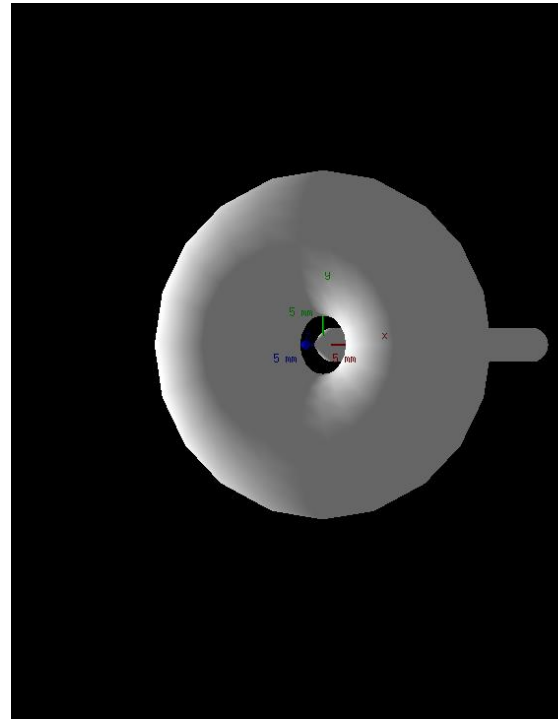

Data Analysis: Scintillator Modeling

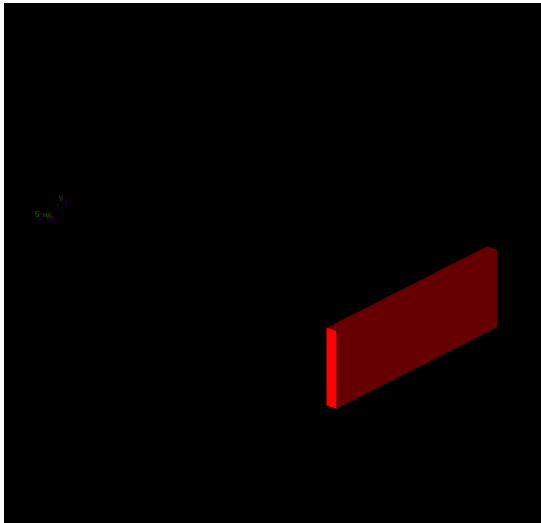

- LYSO easily modeled in GEANT4
- Pictured is a single tile in the configuration of the experiment

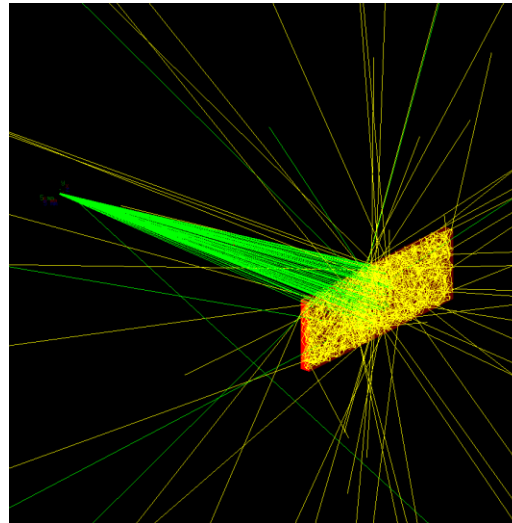

- Propagate modeled Platts energy spectrum through air
- Add scintillation light from scintillator
- Assume a perfectly polished surface

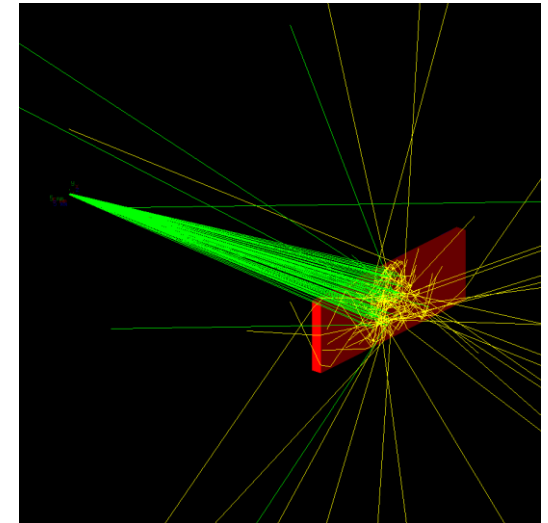

- Add surface effects
- Upstream side has black paint
- Made assumptions about reflection/absorption properties

Data Analysis: Scintillator Evaluation

- Edge spread function of dark field subtracted region doesn't go to zero even at long range
- Beam punch-through of CuW observed
- Beyond beam signal still not in the noise
 - Long-range blur

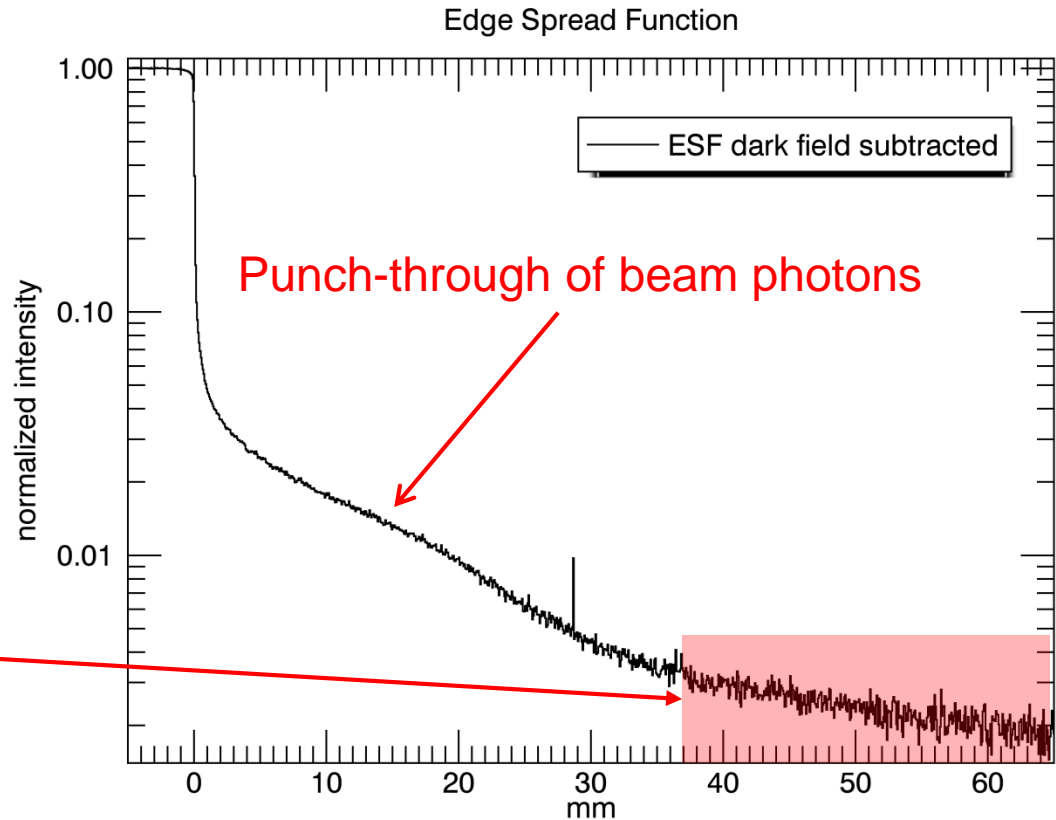

Data Analysis: Scintillator Evaluation

- GEANT4 simulations of the experimental setup made (red)
- X-ray energy deposition in the scintillator shows the range of x-rays
 - Shows punch-through observed in data
- Doesn't account for long-range observation

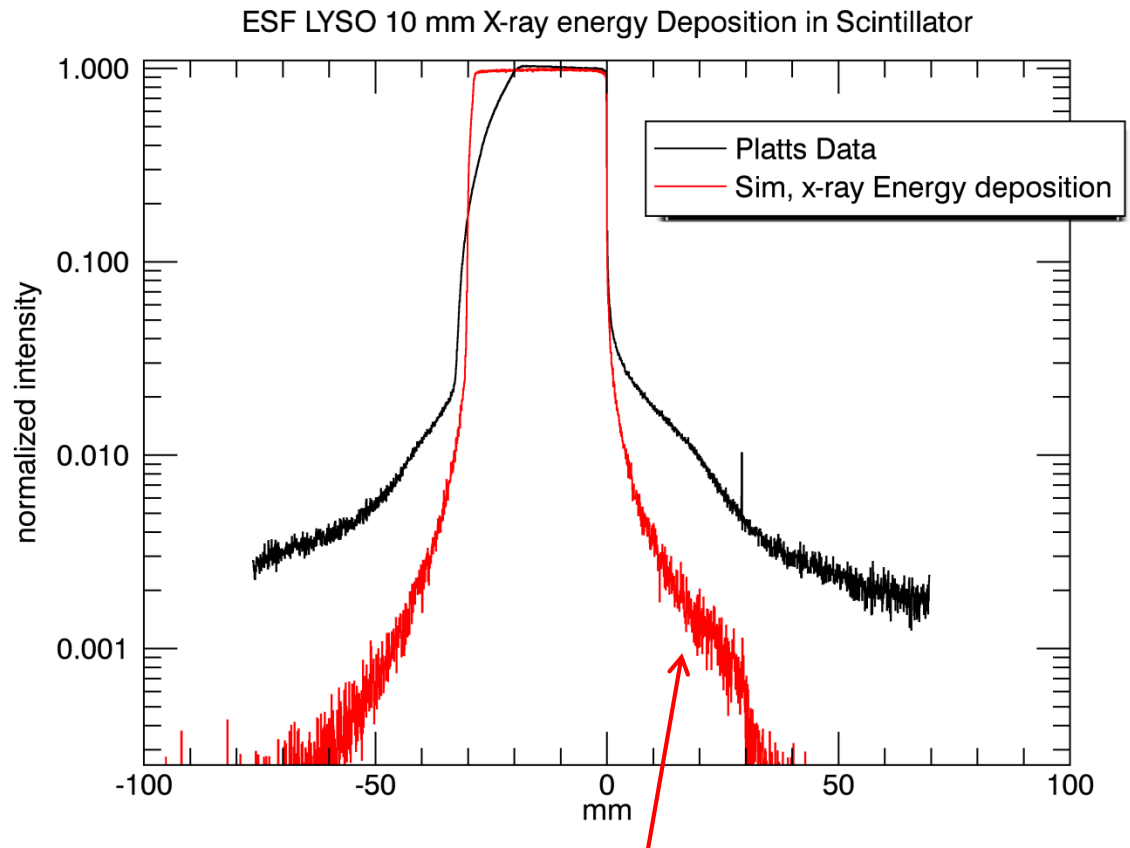

Punch-through of beam photons

Data Analysis: Scintillator Evaluation

- GEANT4 simulations of the experimental setup made (red)
- Scintillation photons are transported
 - Includes LYSO emission spectrum, polished front and sides, and painted back; assumes single tile
 - Absorbs 91%, 20% specular reflection, 20% backscatter, 60% diffuse reflection
- Qualitative agreement seen

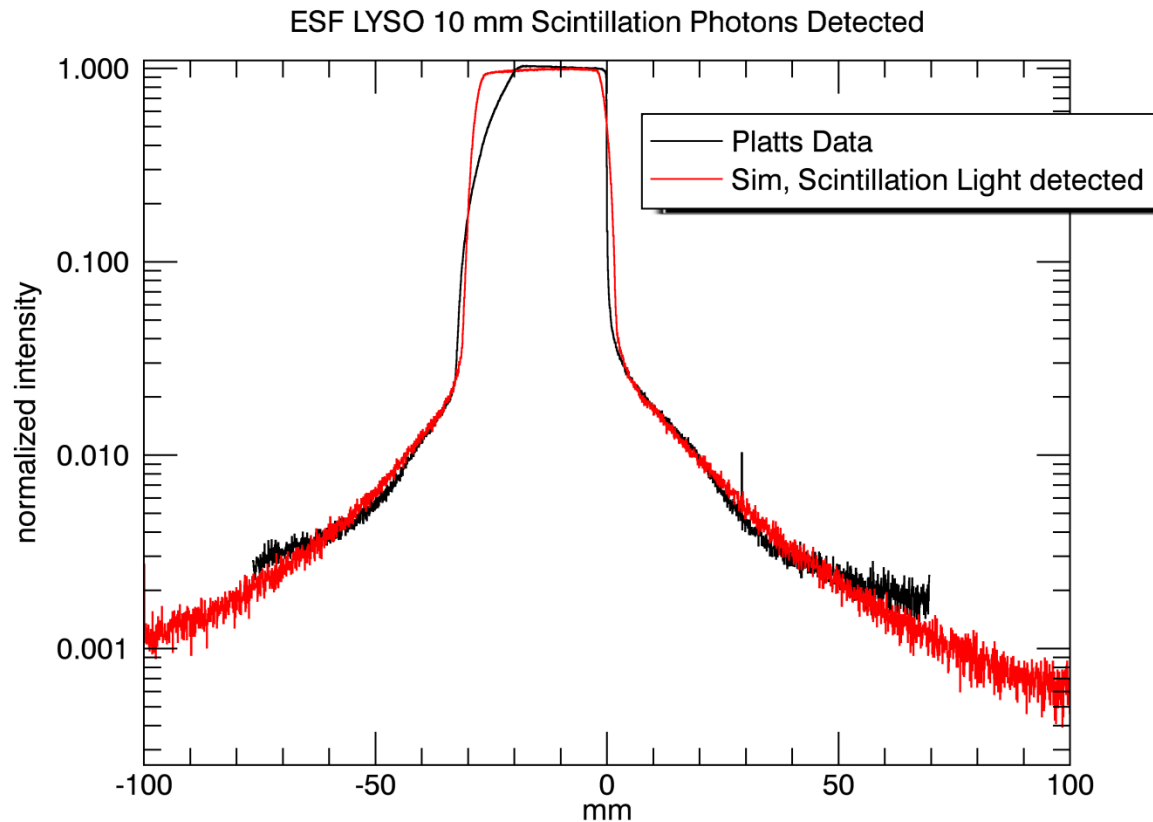

Surface effects can account for long range blur

Data Analysis: Radiography Processing Software, RadPro

- Easy processing of data
 - Designed for minimal user input
- Currently used with Cygnus
- Provides quick-time look of data on site
- Saves option parameters for day-to-day use

