

LA-UR-19-27815

Approved for public release; distribution is unlimited.

Title: Quantum Resources for Noisy Information Processing

Author(s): Girolami, Davide

Intended for: talk delivered at research visit

Issued: 2019-08-05

Disclaimer:

Los Alamos National Laboratory, an affirmative action/equal opportunity employer, is operated by Triad National Security, LLC for the National Nuclear Security Administration of U.S. Department of Energy under contract 89233218CNA000001. By approving this article, the publisher recognizes that the U.S. Government retains nonexclusive, royalty-free license to publish or reproduce the published form of this contribution, or to allow others to do so, for U.S. Government purposes. Los Alamos National Laboratory requests that the publisher identify this article as work performed under the auspices of the U.S. Department of Energy. Los Alamos National Laboratory strongly supports academic freedom and a researcher's right to publish; as an institution, however, the Laboratory does not endorse the viewpoint of a publication or guarantee its technical correctness.

Quantum Resources for Noisy Information Processing

Daive Girolami

Cambridge, August 7, 2019



Index

- ★ Quantum Information Science
- ★ Noisy Quantum Information Processing
- ★ How difficult is it to prepare a quantum state?
- ★ Future

Quantum Information Science

Information Theory

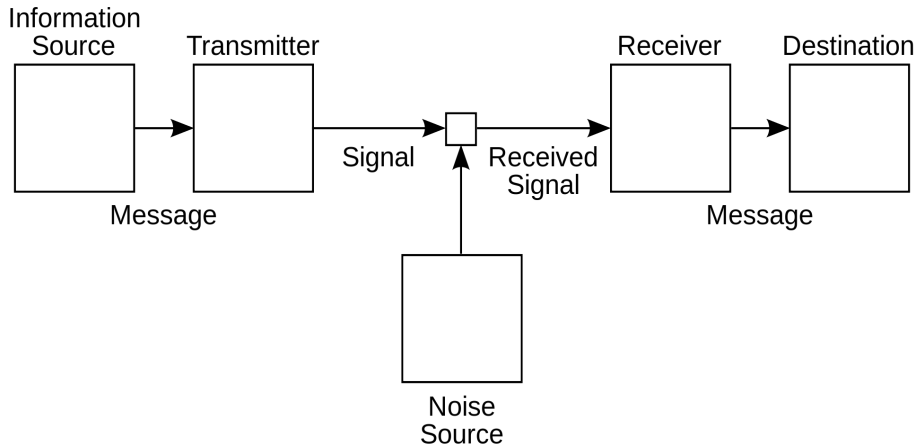

C. Shannon, *Bell Syst. Tech. J.* 27, 379 (1948)

Classical Information

- ★ Information measured in bits: 0, 1
- ★ Encoded in two-level classical systems

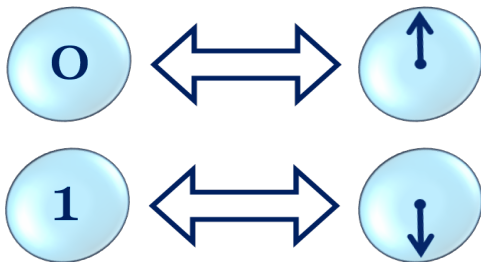

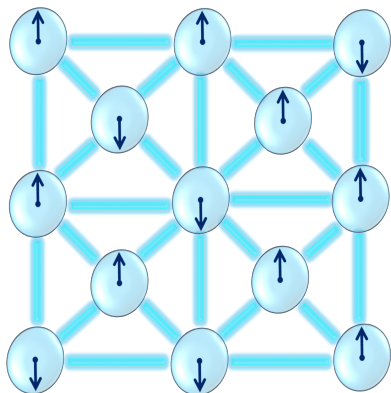
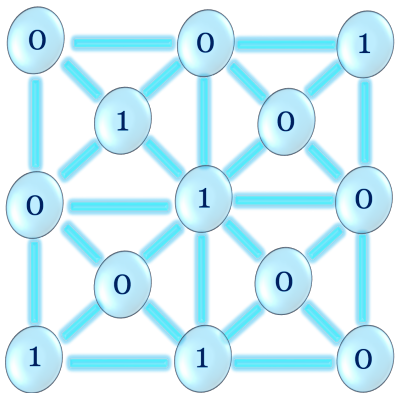

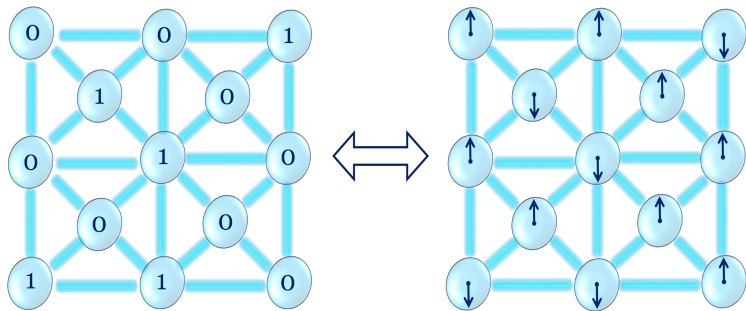

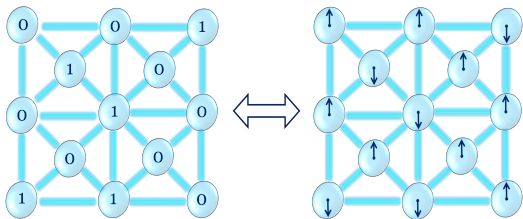

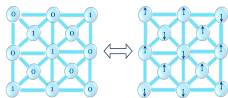



Quantum Information

★ Information encoded in qubits

$$|\psi\rangle = a|0\rangle + b|1\rangle, \quad a, b \in \mathbb{C}$$

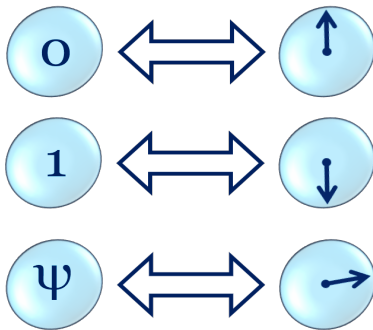

Quantum Information

- ★ Information encoded in entangled qubits

$$|\psi\rangle = a|00\rangle + b|11\rangle, \quad a, b \in \mathbb{C}$$

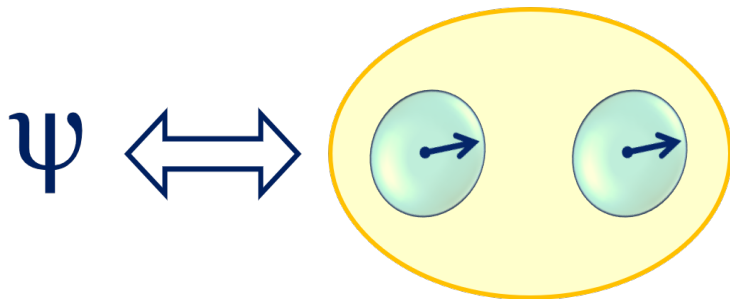

Quantum Information Processing

$$x \xrightarrow{\text{encoding}} \psi_x \xrightarrow{\text{process}} \psi_{\tilde{x}} = U\psi_x \xrightarrow{\text{meas.}} \tilde{x}$$

M. A. Nielsen and I. L. Chuang, *Quantum Computation and Quantum Information*, Cambridge University Press (2000)

QCOMPUTING

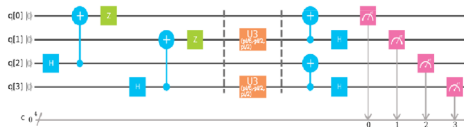

QNETWORKS

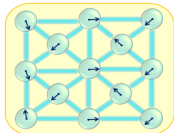

QCOMMUNICATIONS

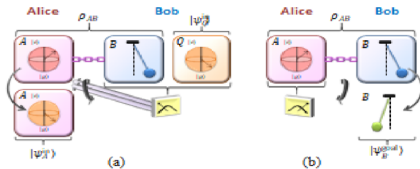

QMETROLOGY

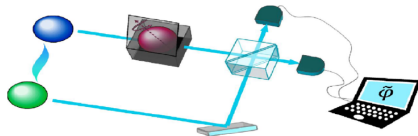

Key point: the source of advantage is always coherence/entanglement of ψ_x

Theory vs Practice

Theory: $|\psi\rangle, U$

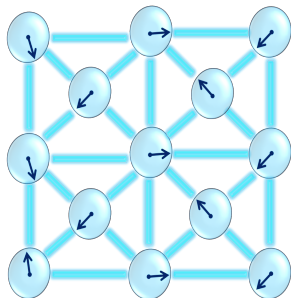

Exp: atoms, photons, etc

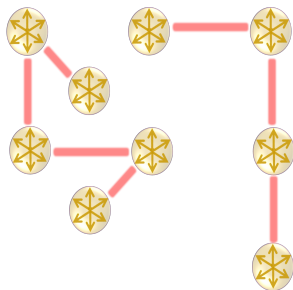

J. Preskill, *Quantum* 2, 79 (2018)

Theory vs Practice

Theory: $|\psi\rangle, U$

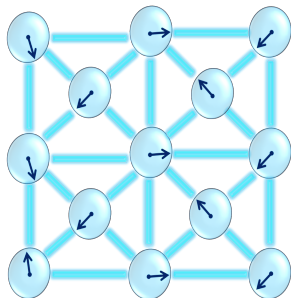

?

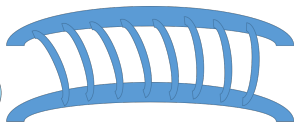

Exp: atoms, photons, etc

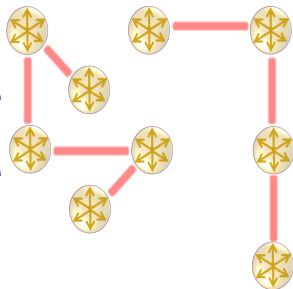

J. Preskill, *Quantum* 2, 79 (2018)

Noisy Quantum Information Processing

Noisy Quantum Information Processing

$$\star \psi \Rightarrow \rho = \sum_i p_i |\psi_i\rangle \langle \psi_i|, \sum_i p_i = \mathbf{1}, \rho = \rho^\dagger \geq \mathbf{0}$$

$$\star U \Rightarrow \Lambda : \Lambda(\rho) \text{ is a quantum state}$$

U. Fano, RMP 29, 74 (1957); E. C. G. Sudarshan et al., Phys. Rev. 121, 920 (1961)

$$\mathbf{x} \xrightarrow{\text{encoding}} \rho_x \xrightarrow{\text{process}} \rho_{\tilde{\mathbf{x}}} = \Lambda(\rho_x) \xrightarrow{\text{meas.}} \tilde{\mathbf{x}}$$

Quantum Resource Theories

- ★ Mathematical methods to identify, quantify and study coherence and correlations in ρ

E. Chitambar, G. Gour, RMP 91, 025001 (2019)

How much quantum is a quantum state ψ ?

$$\star \psi = \alpha |0\rangle + \sqrt{1 - \alpha^2} |1\rangle$$

$$\star \psi_{12} = \alpha |00\rangle_{12} + \sqrt{1 - \alpha^2} |11\rangle_{12}$$

Quantumness of noisy states

$$\rho_{12} = \begin{pmatrix} (1+a)/4 & 0 & 0 & a/2 \\ 0 & (1-a)/4 & 0 & 0 \\ 0 & 0 & (1-a)/4 & 0 \\ a/2 & 0 & 0 & (1+a)/4 \end{pmatrix}$$

★ How much coherence in ρ_{12} ?

★ How much entanglement in ρ_{12} ?

Quantumness of noisy states

$$\rho_{12} = \begin{pmatrix} 0.437 & 0.126 + 0.197i & 0.0271 - 0.0258i & -0.274 + 0.0997i \\ 0.126 - 0.197i & 0.154 & -0.0115 - 0.0187i & -0.0315 + 0.170i \\ 0.0271 + 0.0258i & -0.0115 + 0.0187i & 0.0370 & 0.00219 - 0.0367i \\ -0.274 - 0.00997i & -0.0315 - 0.170i & 0.00219 + 0.0367i & 0.372 \end{pmatrix}$$

★ How much coherence in ρ_{12} ?

★ How much entanglement in ρ_{12} ?

Resource hierarchy in bipartite systems

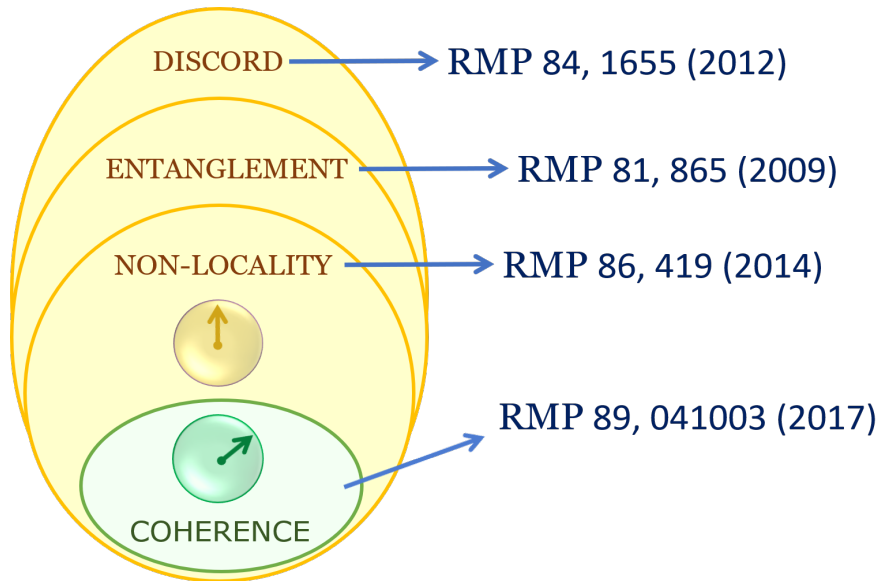

Discord: Quantumness without Entanglement

★ **Discord:** $\rho_{12} \neq \sum_{ij} p_{ij} |i\rangle \langle i|_1 \otimes |j\rangle \langle j|_2, \sum_{ij} p_{ij} = 1$
L. Henderson, V. Vedral, J. Phys. A 34, 6899 (2001); H. Ollivier, W. H. Zurek, PRL 88, 017901 (2002).

★ **Entanglement:** $\rho_{12} \neq \sum_i p_i \rho_1^i \otimes \rho_2^i, \sum_i p_i = 1$

! Methods to compute Discord

D. Girolami, G. Adesso, PRL 108, 150503 (2012); I. Almeida, D. Girolami, et al., PRL 109, 190502 (2012); G. Adesso, D. Girolami, A. Serafini, PRL 110,140501 (2013)

Discord as a resource for noisy phase estimation !

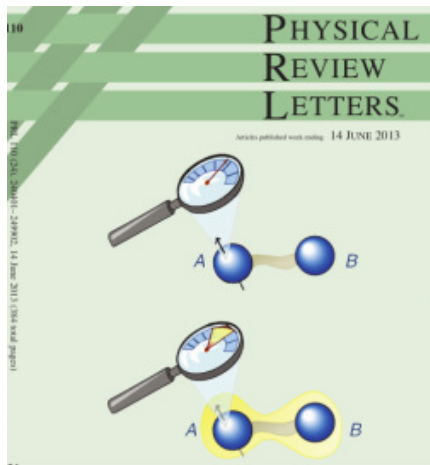

Discord = minimum sensitivity to local perturbation

D. Girolami, T. Tufarelli, G. Adesso, PRL 110, 240402 (2013), Editors' Suggestion and Cover

Experimental implementation

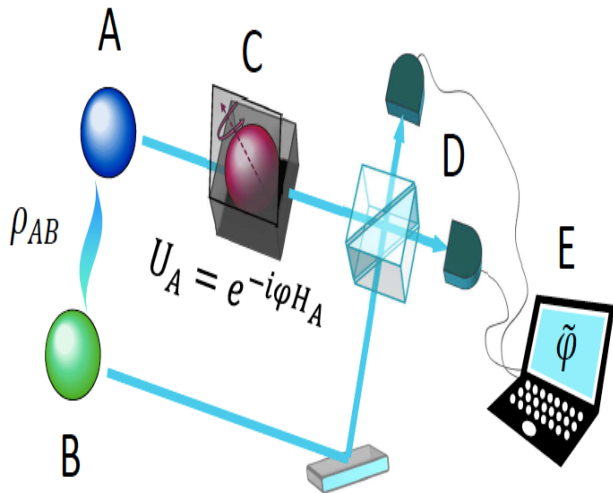
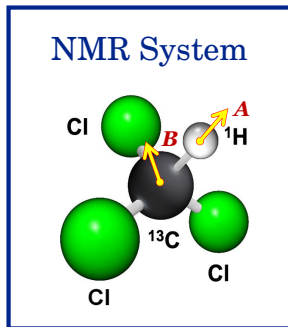

D. Girolami et al., PRL 112, 210401 (2014), Editors' Suggestion

Detection

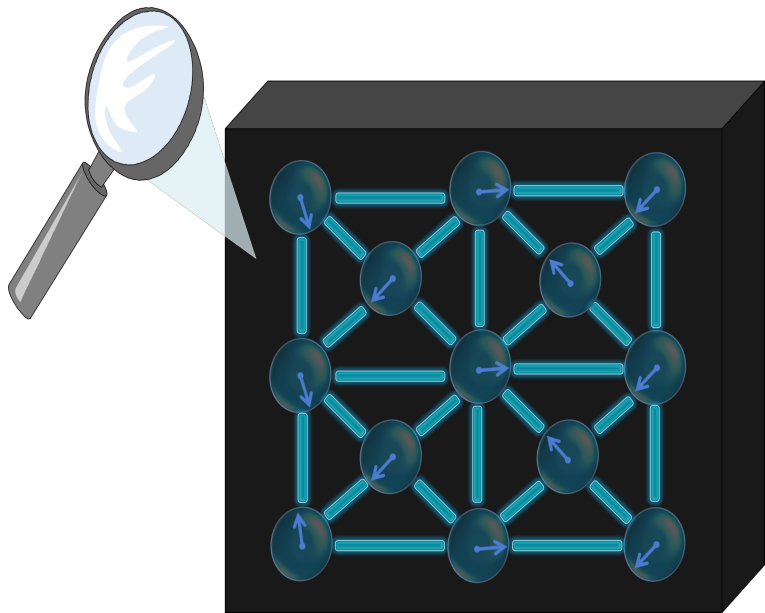

Detecting resources in n noisy qubits

- ★ $O(4^n)$ measurements to reconstruct ρ
- ★ We just need to know about resources...
- ★ Yet, they are not directly measurable, i.e. not linear!

Result: Detecting Coherence in noisy qubits

- ★ Coherence/Superposition: $\rho \neq \sum_{\tilde{i}} \lambda_{\tilde{i}} |\tilde{i}\rangle \langle \tilde{i}|$
- ★ Solution: prepare two copies ρ_1, ρ_2 and rotate $U\rho_2U^\dagger, U = e^{-iHt}, H = \sum_i h_i |\tilde{i}\rangle \langle \tilde{i}|$
- ★ Iff $\text{Tr}(\rho^2) \neq \text{Tr}(\rho U \rho U^\dagger)$, there is coherence in Ham. eigenbasis $|\tilde{i}\rangle$
- ★ Experimental scheme to evaluate $\text{Tr}(\rho^2), \text{Tr}(\rho U \rho U^\dagger)$ with $O(3^n)$ measurements

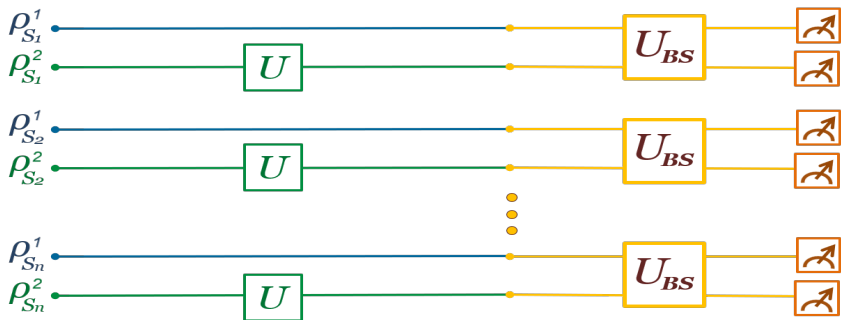
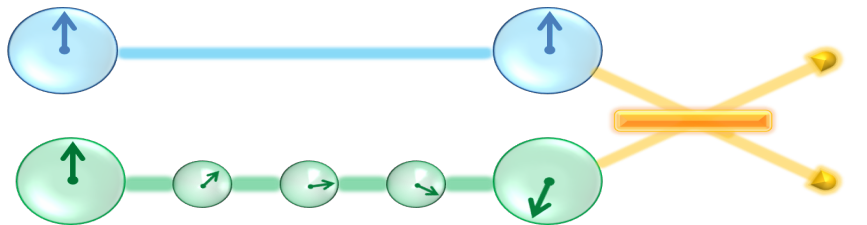

C. Zhang et al. PRA 96, 042327 (2017)

How difficult is it to prepare a
quantum state?

D. Girolami, PRL 122, 010505 (2019), Editors'
Suggestion

Quantumness vs experimental resources

- ★ $|001010\rangle \rightarrow |101011\rangle$ is classical, i.e. easy
- ★ $U_H |0\rangle = (|0\rangle + |1\rangle)/\sqrt{2}$ is not easy
- ★ $U_{\text{CNOT}} |+\rangle |0\rangle = (|00\rangle + |11\rangle)/\sqrt{2}$ is not easy
- ★ How many non-easy gates are needed for $\rho \rightarrow \tau$?

Geometry of a process γ_t

★ Quantum map:

$$\gamma_t = \sum_i \lambda_i(t) |i(t)\rangle \langle i(t)|, t \in [0, T]$$

★ $\gamma : t \rightarrow \gamma_t$ is curve on the manifold of states \mathcal{M}
from $\gamma_0 \equiv \rho$ to $\gamma_T \equiv \tau$

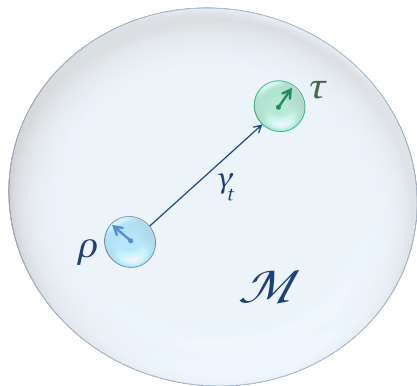

Classical operations: $\gamma_t \in \mathcal{M}_{i_R}, \forall t$

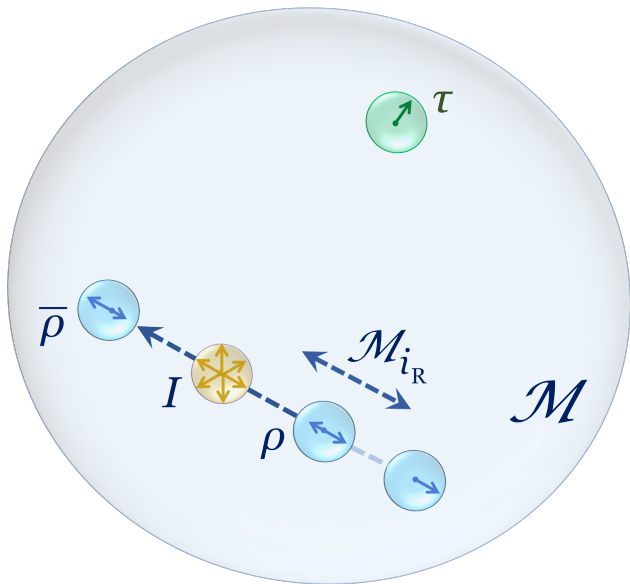

Differential Geometry on \mathcal{M}

★ Energy of curve γ_t :

$$\mathbf{E}^{\gamma_t}(\rho \rightarrow \tau) := \int_0^T \|\dot{\gamma}_t\|^2 dt, \gamma_0 \equiv \rho, \gamma_T \equiv \tau$$

$$\star \mathbf{E}^{\gamma_t}(\rho \rightarrow \tau) = \mathbf{E}_c^{\gamma_t}(\rho \rightarrow \tau) + \mathbf{E}_q^{\gamma_t}(\rho \rightarrow \tau)$$

S. Amari and H. Nagaoka, *Methods of Information Geometry* (American Math. Soc., 2007); I. Bengtsson and K. Zyczkowski, *Geometry of Quantum States* (Cambridge University Press, Cambridge, 2007)

Geometric measure of quantumness

$$Q_\rho(\tau) := \min_{\tilde{\rho} \in \mathcal{M}_{i_R}, \tilde{\gamma}_t: \tilde{\rho} \rightarrow \tau} E_q^{\tilde{\gamma}_t}(\tilde{\rho} \rightarrow \tau)$$

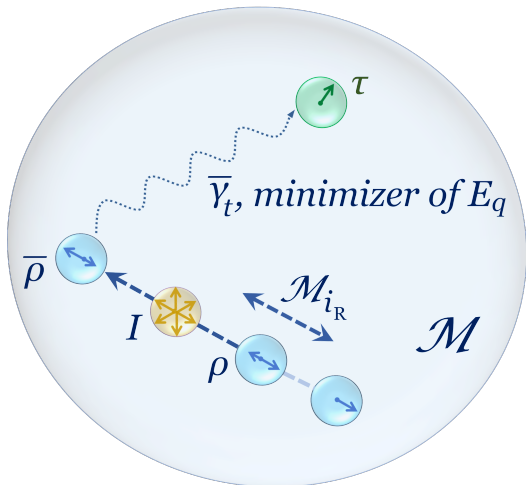

$$Q_{\rho}^u(\tau) := \mathbf{E}^{\bar{\gamma}_t^u}(\bar{\rho}^u \rightarrow \tau) \geq Q_{\rho}(\tau)$$

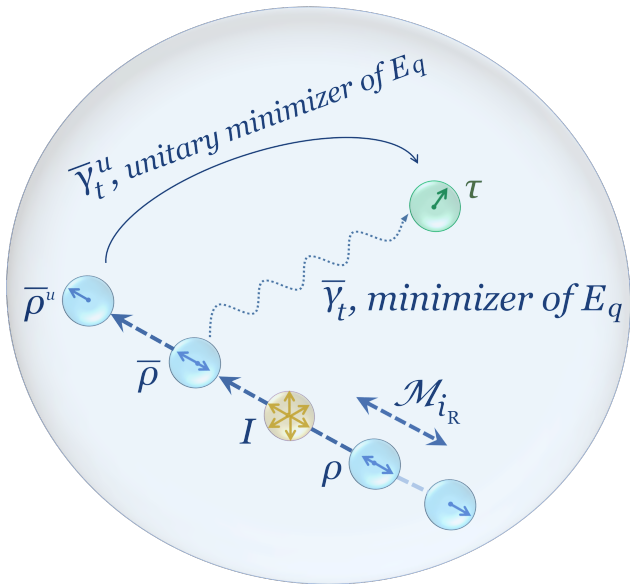

Optimal path $\bar{\gamma}_t^u = |\bar{\gamma}_t^u\rangle \langle \bar{\gamma}_t^u|$, pure target
 $\tau = |\psi_\tau\rangle \langle \psi_\tau|$

$$|\psi_{\bar{\gamma}_t^u}\rangle = (\cos \theta - \sin \theta / \tan d) |\psi_{\bar{\rho}^u}\rangle + (\sin \theta / \sin d) |\psi_\tau\rangle$$

$$\theta = d t / T, d := D_{\text{FS}}(\psi_{\bar{\rho}^u}, \psi_\tau)$$

A. Uhlmann, Rep.Math.Phys. 9, 273 (1976); H. N. Barnum, *Quantum Information Theory*, PhD Thesis, University of New Mexico (1998)

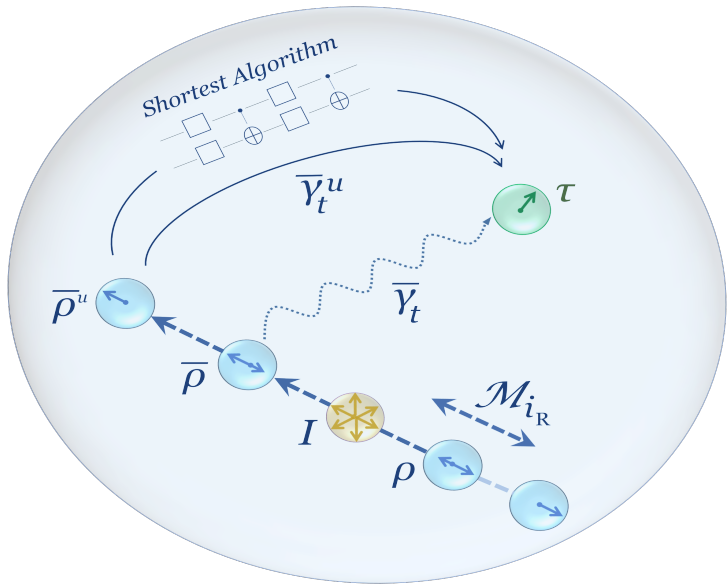

Bound for commuting gates

$$\star \quad |+\rangle \otimes |0\rangle^{\otimes N} \rightarrow |0\rangle^{\otimes (N+1)} + |1\rangle^{\otimes (N+1)}$$

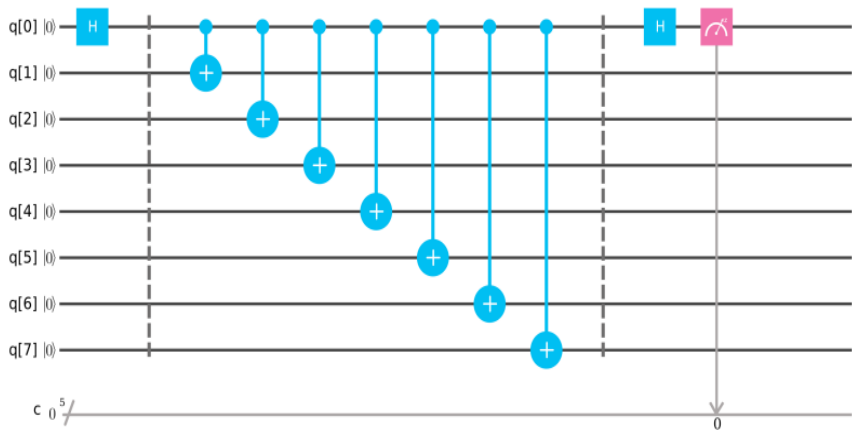

Bound for commuting gates

$$\star \tau = e^{-iHT} \rho e^{iHT}$$

$$\star H = \sum_{i=1}^N H_i, [H_i, H_j] = 0$$

$$\star E^i = h_{\max}^i - h_{\min}^i, E = \sum_i E^i / N$$

S. Boixo, S. T. Flammia, C. M. Caves, J. M. Geremia, PRL 98, 090401 (2007); M. Zwierz, C. A. Perez-Delgado, P. Kok, PRL 105, 180402 (2010)

$$N_{\text{gates}} E \sqrt{T} \geq 2 \sqrt{Q_{\rho}^u(\tau)}$$

Future

1) Quantifying Multipartite Quantum Resources

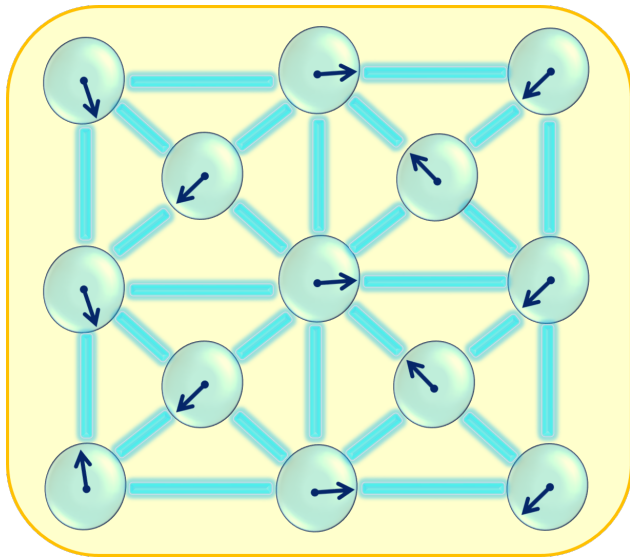

- ? Quantifying multipartite correlations, in particular genuine k -partite correlations
- ? Detecting multipartite correlations (quantitative bounds with $O(n)$ measurements)

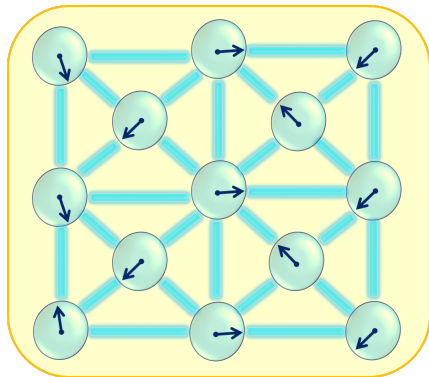

2) Optimizing Noisy QIP

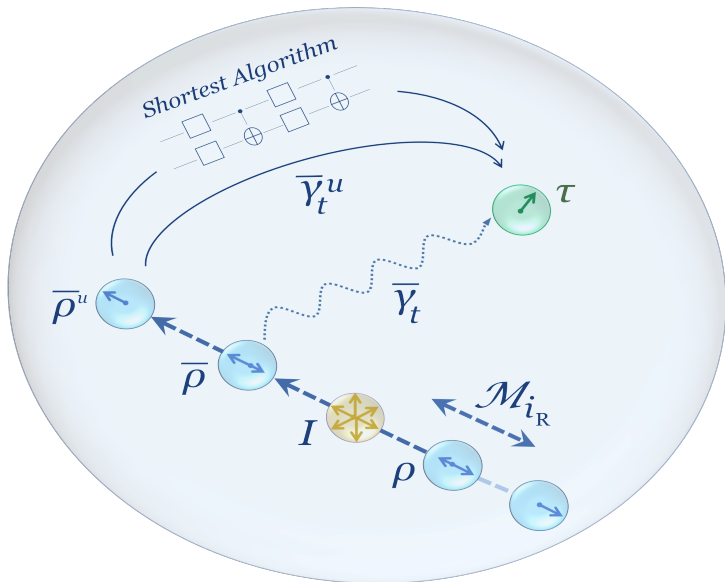

- ? Bounds and optimal strategies for non-commuting gate algorithms
- ? Bounds and optimal strategies for dynamics engineering

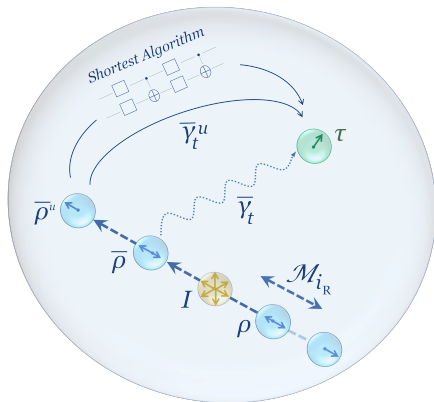

Optimizing Control of Noisy QIP

Environment

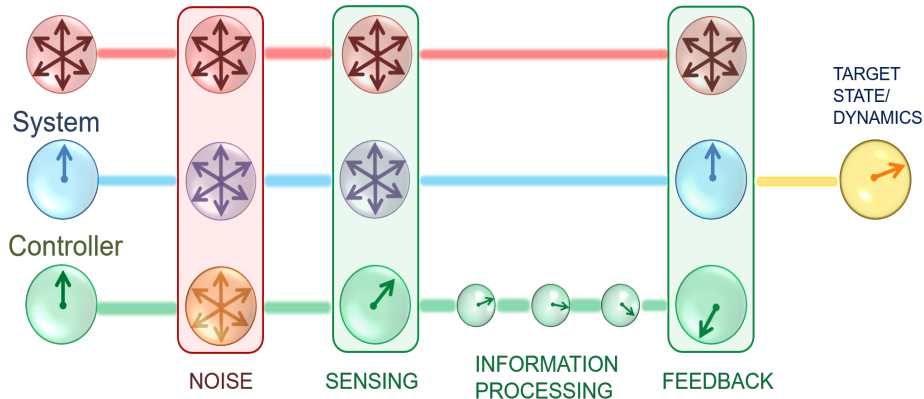

? Bounds and optimal strategies for feedback controlled state engineering

? Bounds and optimal strategies for feedback controlled dynamics engineering

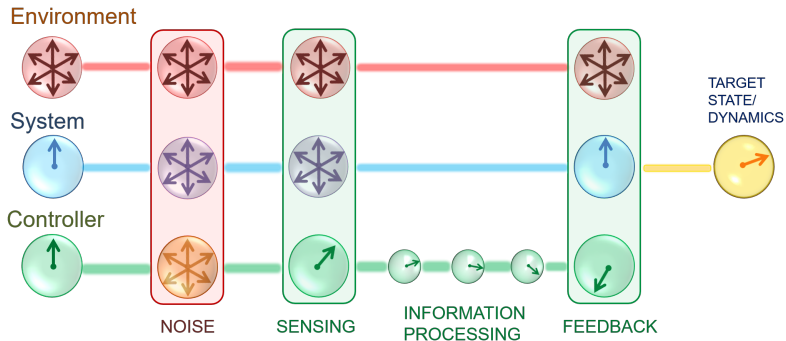

Summary

- ★ Quantum Information Science
- ★ Noisy Quantum Information Processing
- ★ How difficult is it to prepare a quantum state?
- ★ Future

The End

Email: davegirolami@gmail.com

Website: <https://sites.google.com/site/davegirolami/>