

energy.sandia.gov

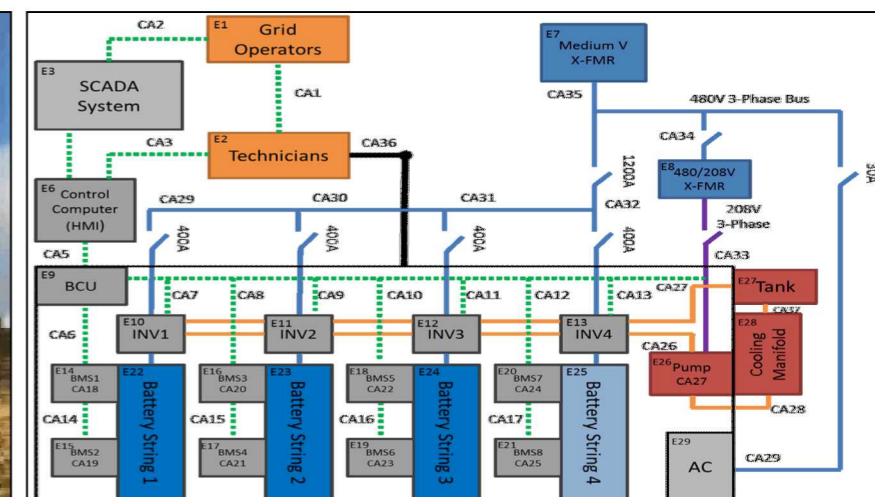

## Energy Storage Hazard Analysis and Risk Management

09/24/2015 - David Rosewater, Adam Williams,  
Don Bender, Josh Lamb, Summer Ferreira



Sandia National Laboratories is a multi-program laboratory managed and operated by Sandia Corporation, a wholly owned subsidiary of Lockheed Martin Corporation, for the U.S. Department of Energy's National Nuclear Security Administration under contract DE-AC04-94AL85000

# Project Overview: Scope

Advance the State of the  
Art in Energy Storage  
Safety Analysis

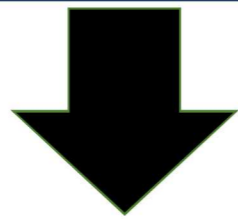

Ensure Impact Through  
Publication and  
Collaboration with Industry  
Stakeholders

**Leveraged by Sandia's  
Expertise in:**

- Battery Safety Testing
- Hydrogen Safety
- Nuclear Power Plant Safety
- Cyber Security

# Project Overview: Purpose

“The operational safety of large storage systems is a concern and will be a barrier in their deployment in urban areas or in proximity of other grid resources such as substations. Design practices that incorporate safety standards and safety testing procedures for the different storage technologies need to be developed and codified.”

-Grid Energy Storage, DOE, December, 2013

## **Risk Assessment and Management**

**Goal:** The framework and methodologies for assessing and managing deployment risk for ESS are accepted and adopted by industrial and regulatory stakeholders.

-Energy Storage Safety Strategic Plan, DOE OE, December, 2014

# Impacts

## Publications

- D.M. Rosewater, A. D. Williams “**Analyzing System Safety in Lithium-Ion Grid Energy Storage,**” Presently Under Review with the Journal of Power Sources
- D. Bender “**Recommended Practices for the Safe Design and Operation of Flywheels**” Undergoing external expert review before Sandia publication

## Other Contributions

- Collaboration with EPRI on the preparation of Energy Storage Integration Council “**Guide to Safety in Utility Integration of Energy Storage Systems**” – Safety subgroup lead
- **Served on Standards Technical Panel for UL 9540** Outline of Investigation for Energy Storage Systems and Equipment
- Assisted in the formation of the ESSWG and now lead of the **Safety Outreach and Incident Response** group

# Impacts<sub>(continued.)</sub>

## Conference Papers and Presentations on ESS Safety

### **Engineering Systems Theory Applied to Stationary Energy Storage Safety**

- Battery Safety, Washington DC, November 2014

### **Safety Validation in Grid Energy Storage**

- EASE Global, Paris France, November 2014

### **System's Safety in Grid Energy Storage: Challenges and Solutions through the Application of STAMP**

- STAMP Workshop, Boston MA, March 2015

### **Hazard Analyses in Complex Energy Storage Systems**

- Next Generation Batteries, San Diego CA, April 2015

### **Intro to FMEA and SSA in Energy Storage**

- ESA Annual Meeting, Dallas TX, June 2015

### **Guide to Safety in Utility Integration of Energy Storage Systems**

- California PUC Hearing, San Francisco CA, August 2015

# Advancing the State of the Art in Energy Storage Safety Analysis

# Probability Risk Assessment (PRA)

Analysis answers three questions:

1. **What** can go wrong?
2. How **likely** is that?
3. How **bad** would that be?

PRA Consists of a combination of Event trees and Fault trees

## Example Fault Tree: If...

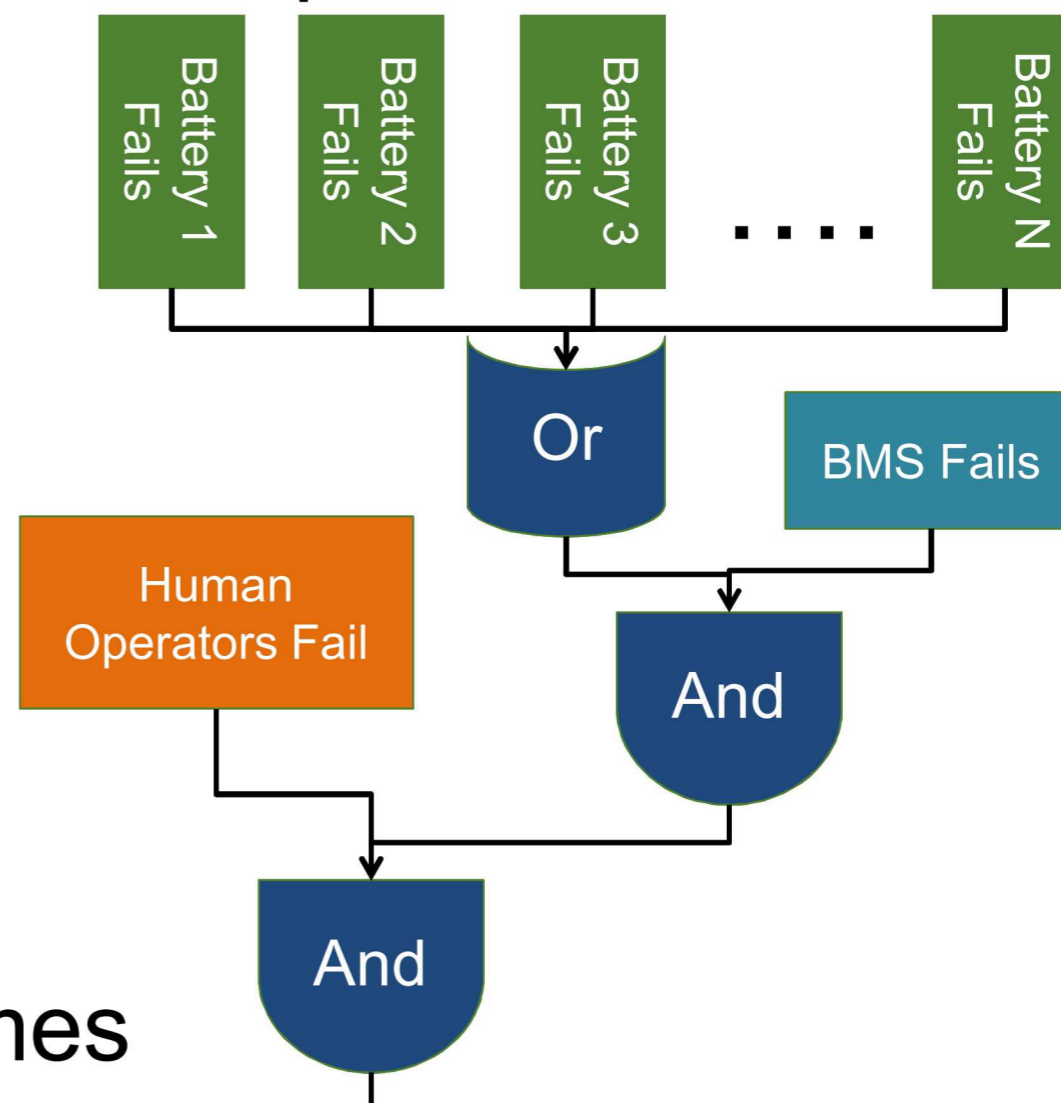

Example Event Tree: tracks deterministic events and outcomes

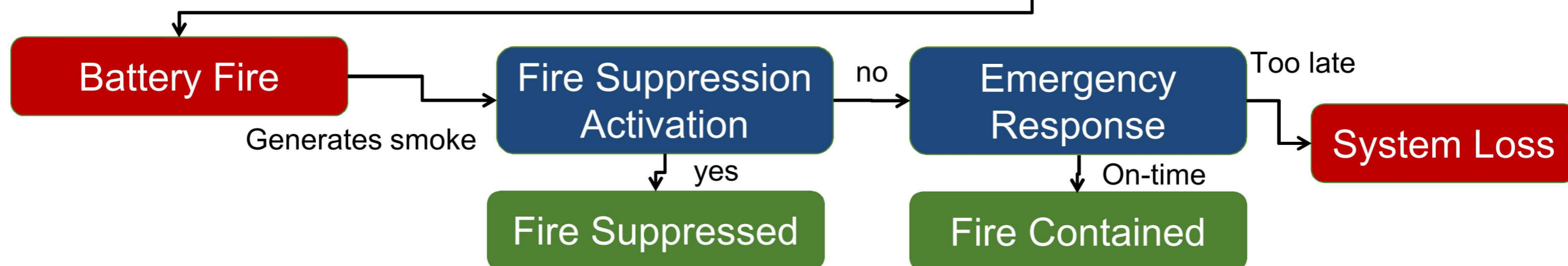

# Systems Thinking

Many components, interacting in simple ways, can develop complex emergent patterns of behavior .

Carbon Analogy: Structure



Rob Lavinsky, iRocks.com – CC-BY-SA-3.0 [CC-BY-SA-3.0 (<http://creativecommons.org/licenses/by-sa/3.0/>)], via Wikimedia Commons

Traffic Analogy: Emergence



By User:Diliff (Own work) [GFDL (<http://www.gnu.org/copyleft/fdl.html>), CC-BY-SA-3.0 (<http://creativecommons.org/licenses/by-sa/3.0/>) or CC-BY-SA-2.5 (<http://creativecommons.org/licenses/by-sa/2.5/>)], via Wikimedia Commons

Sand Analogy: Hierarchy



By Shiraz Chakera <http://www.flickr.com/photos/shirazc/> (<http://www.flickr.com/photos/shirazc/3387882509/>) [CC-BY-SA-2.0 (<http://creativecommons.org/licenses/by-sa/2.0/>)], via Wikimedia Commons

“With systemic thinking, we recognize that "the cause" frequently lies in the very structure and organization of the system.” (Senge 1990)

# Systems Thinking (Safety)

“Safety is an emergent property that arises when system components interact with each other within a larger environment.”

(Leveson 2012)

## Battery Cell Properties



Kristoferb [CC-BY-SA-3.0 (<http://creativecommons.org/licenses/by-sa/3.0>) or GFDL (<http://www.gnu.org/copyleft/fdl.html>)], via Wikimedia Commons

- ✓ Capacity
- ✓ Volatility
- ✓ Temperature Range
- ✗ Safety

“Safety” is not a property of a component

## Battery System Properties



By Jelson25 (Own work) [CC-BY-3.0 (<http://creativecommons.org/licenses/by/3.0>)], via Wikimedia Commons

- ✓ Capacity
- ✓ Service Life
- ✓ Control
- ✓ Algorithm
- ✓ Safety

Safety is a system property

If safety is an emergent property, why/how do accidents happen?

# STAMP – New Accident Model

Systems-Theoretic Accident Model and Processes [Leveson, 2012]

Accidents occur when interactions violate **safety constraints**,  
The system enforces these constraints using control.

Being evaluated for use by: [Leveson, 12, 13, 14]

- Boeing
- EPRI
- NRC
- VOLPE
- Etc.

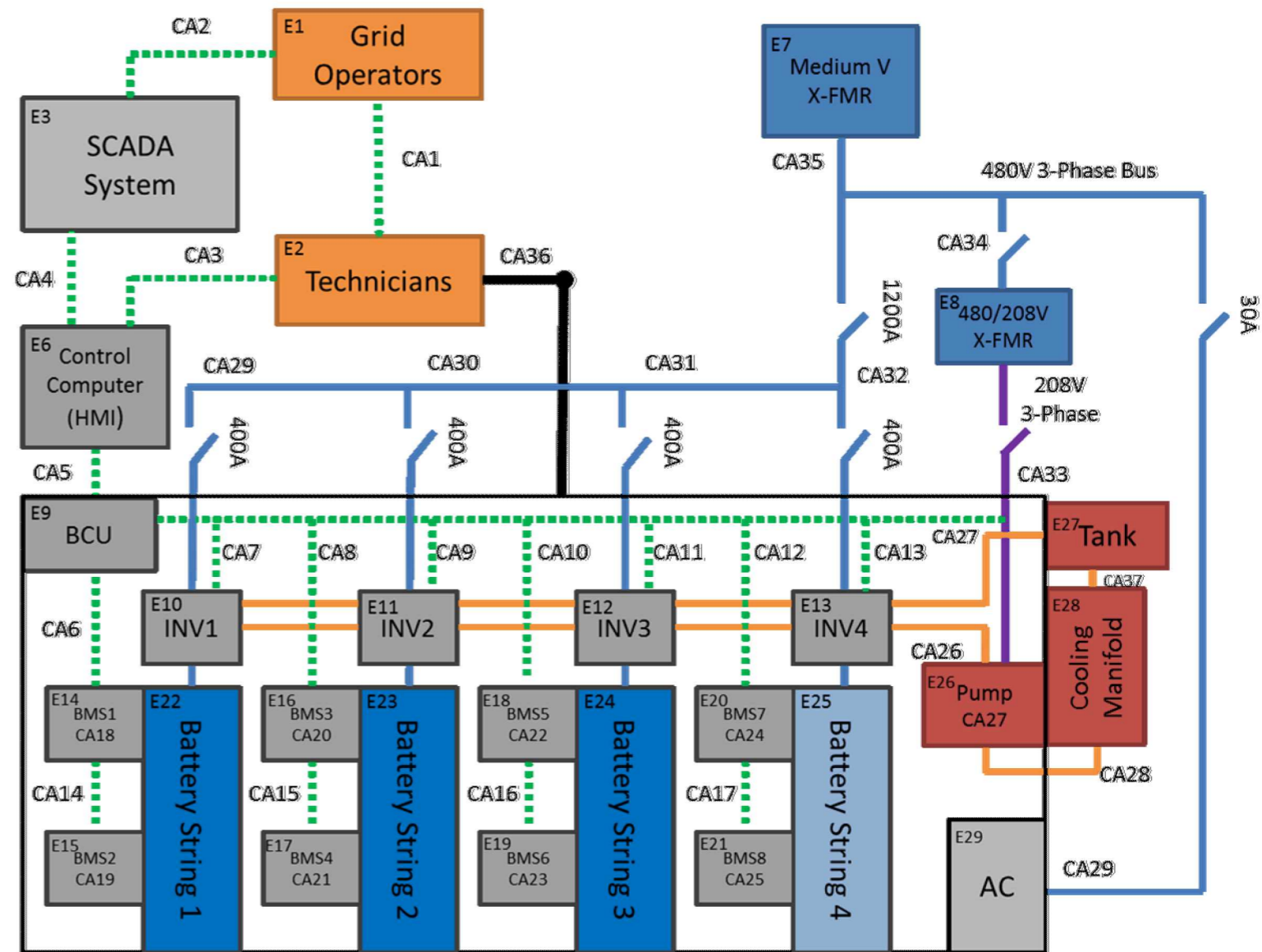

Illustrative Example of a Safety Control Structure

# Application of STAMP to BESS

- Safety Constraints can be rigorously assessed using a combination of analysis and testing.
- System's Theoretic Process Analysis (STPA):
  - Identify the Accidents, Hazards, Safety Control Structure, and the Safety Responsibilities
  - Step 1: Find unsafe control actions
  - Step 2: Determine causal factors
- A hazard analysis can be a useful tool in managing and communicating the safety of complex battery systems
- There is much more to safety than making batteries inert under abuse conditions

# Conclusion

## Impacts

- The state of the art in energy storage safety has been improved
- Impact has been assured through publication and collaboration
- Advanced hazard analysis techniques are now more accessible to the energy storage industry

## FY 16

- Lead the Safety Outreach and Incident Response group as part of the ESSWG
- Publish analysis and testing protocol for safety validation based on advanced hazard analysis techniques

This work was funded by the US DOE OE. Special thanks to Dr. Imre Gyuk for working to develop the ES industry and supporting Sandia's ES Program.

Questions?

David Rosewater

[dmrose@sandia.gov](mailto:dmrose@sandia.gov)

505-844-3722