



# Hydrogen Femtosecond Vibrational CARS Thermometry in Solid Propellant Flames

Daniel Richardson, Sean Kearney, Daniel Guildenbecher  
Sandia National Laboratories

OSA Imaging and Applied Optics Congress June 25–28<sup>th</sup>, 2018

# Introduction

## Sandia Mission Space:

- DOE strategic systems safety
- Defense systems
- Homeland security
- Energy
- Large scale/challenging environments



# Previous Research: Propellant Combustion

## Modeling Efforts

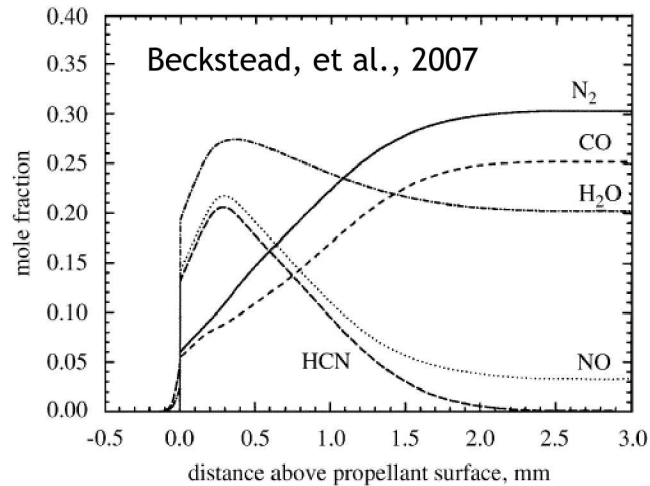

## Emission Spectroscopy

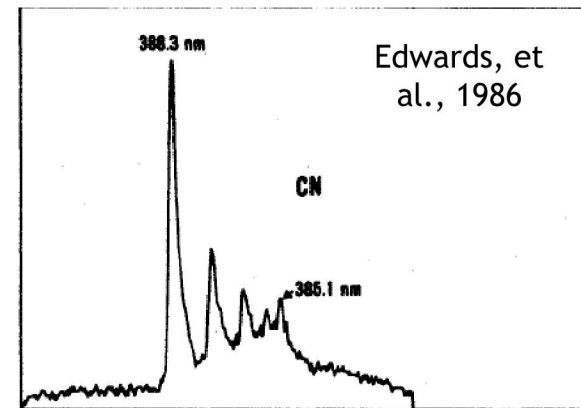

## CN PLIF

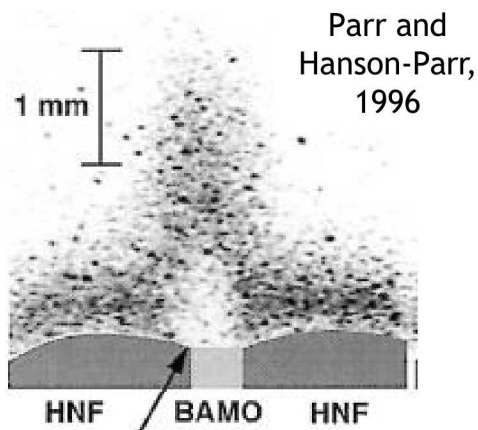

## OH LIF

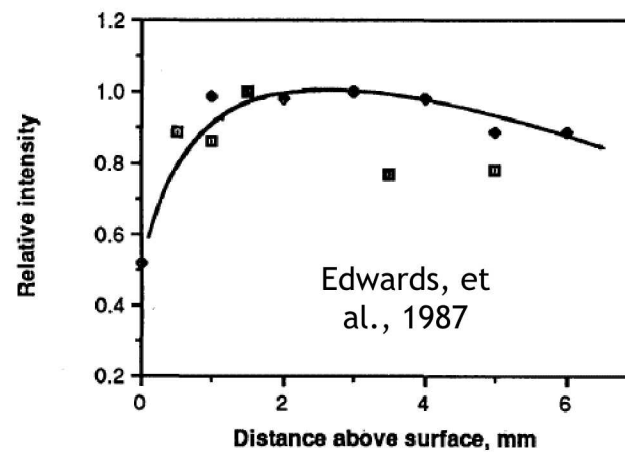

## Mass Spectroscopy

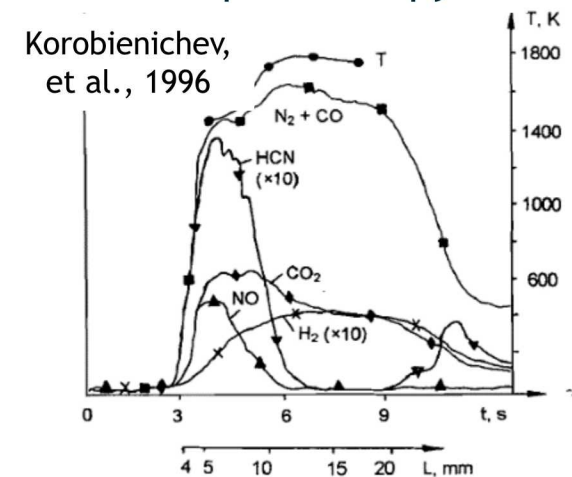

# Previous Research: Propellant Combustion

## H<sub>2</sub> ns CARS

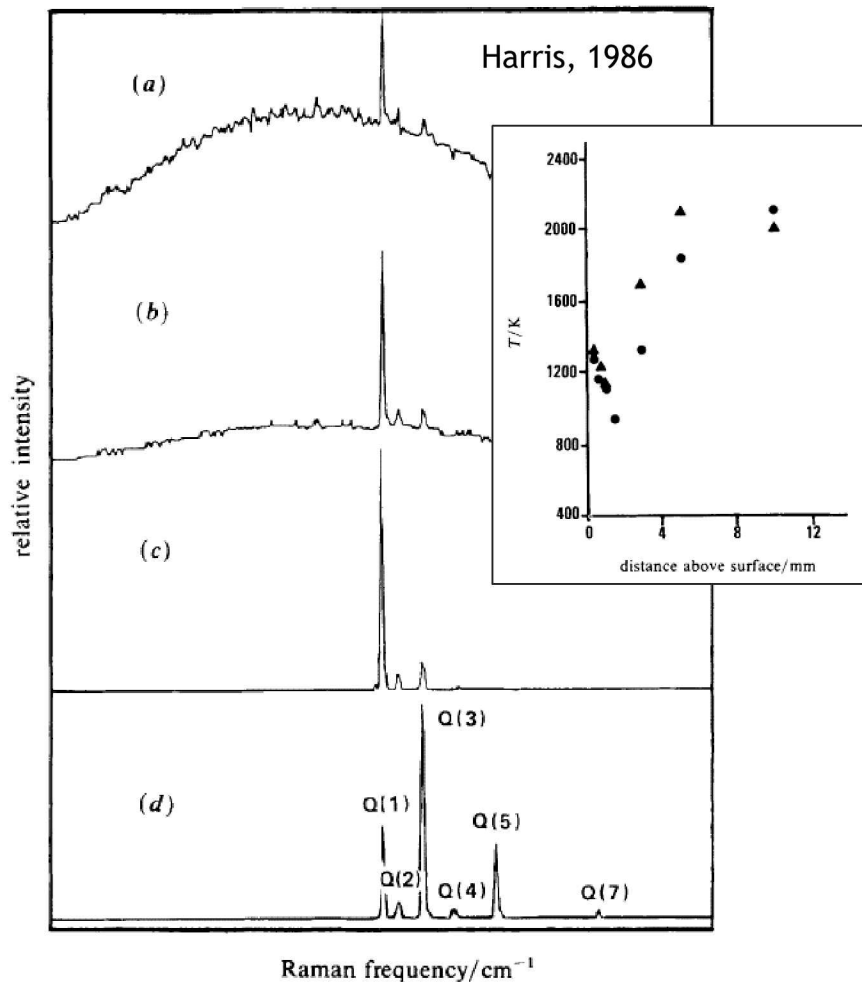

## Multi-Broadband ns CARS

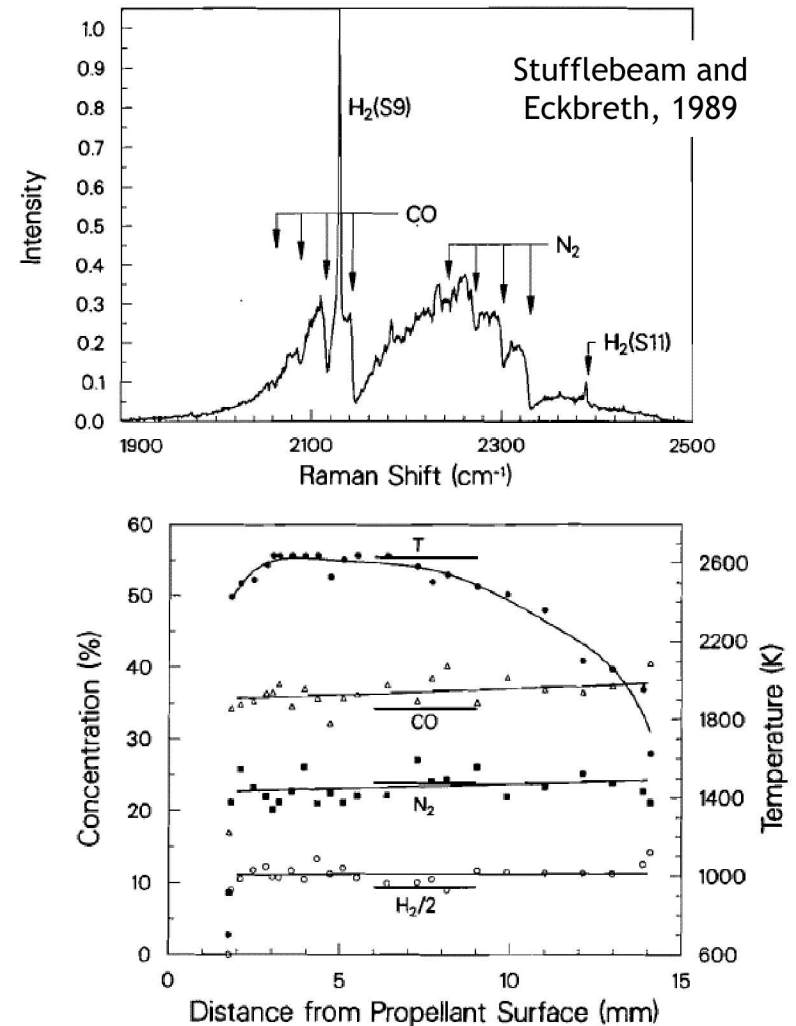

# Metalized Propellant Combustion

## Challenging Diagnostic Environment:

- Temperatures  $>3000$  K
- 10-300  $\mu\text{m}$  particles
- Bright flames
- Complex chemistry

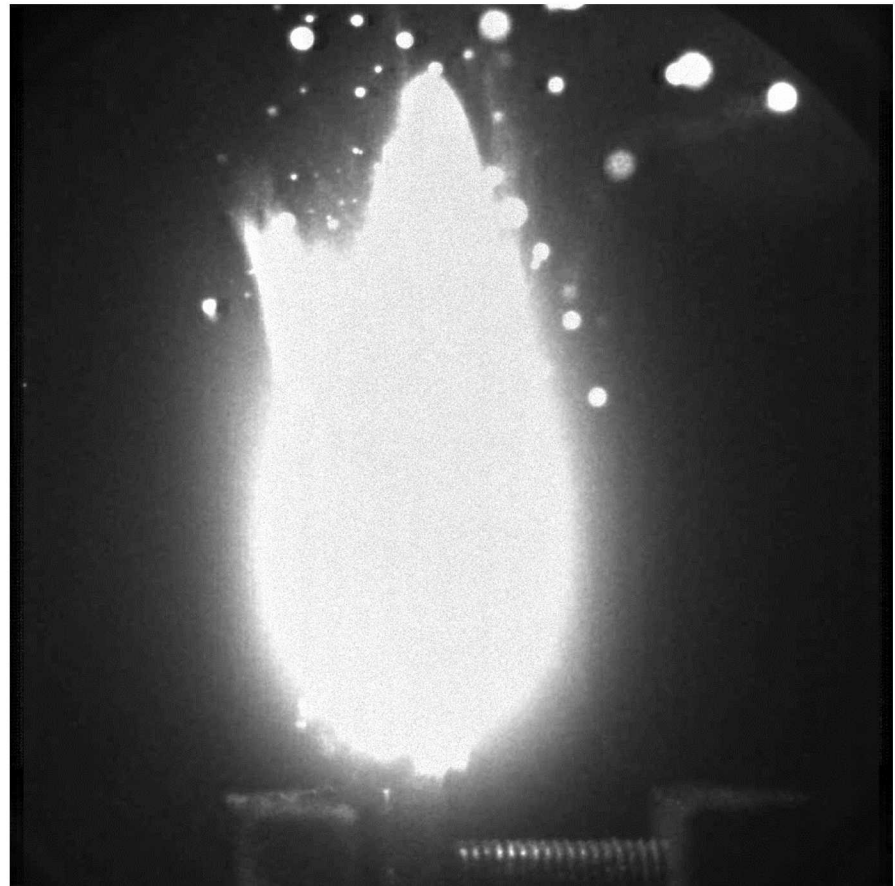

# 6 Metalized Propellant Combustion

## Particle Size Measurements via DIH

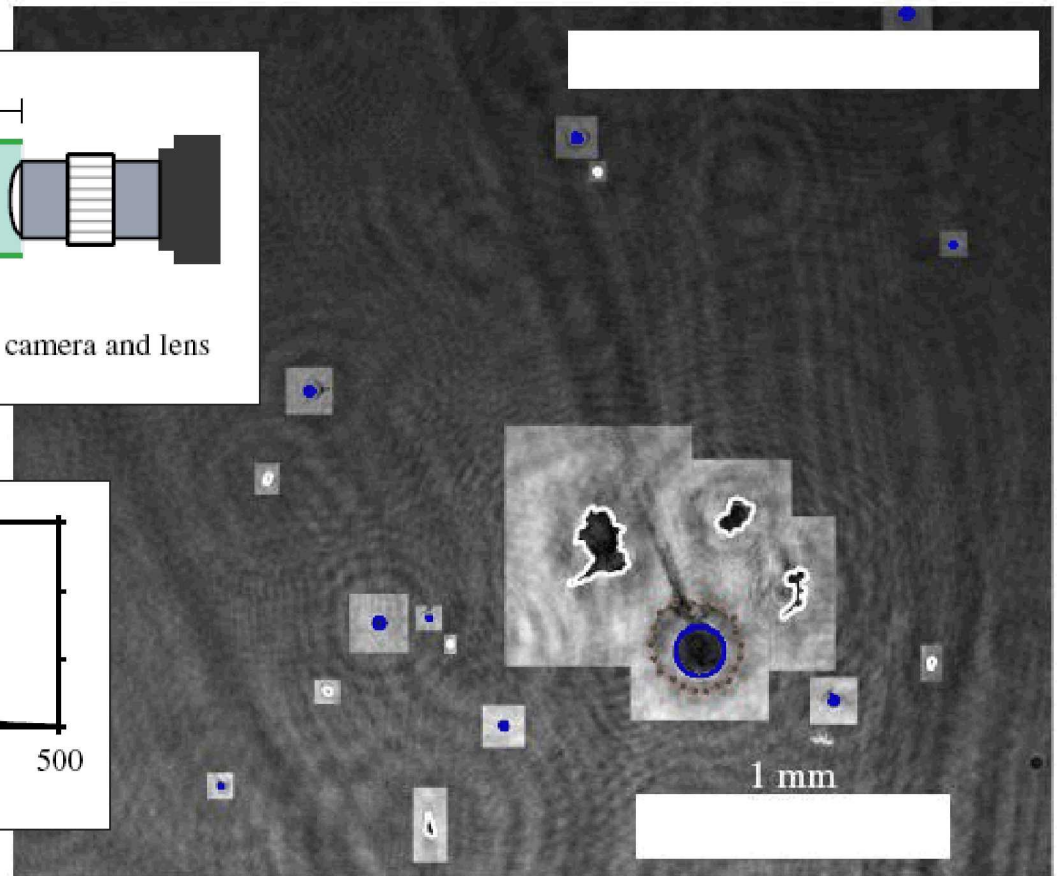
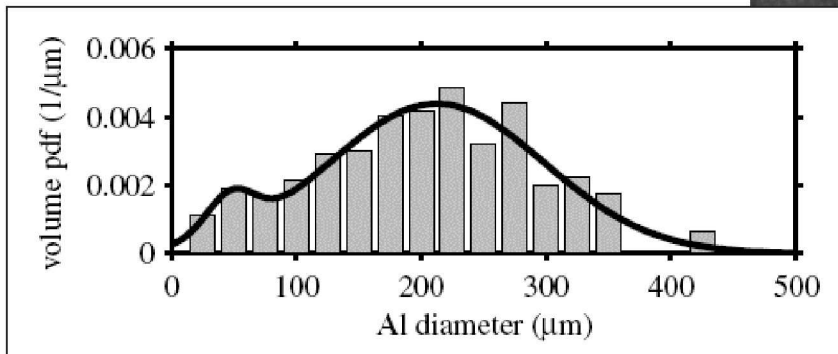
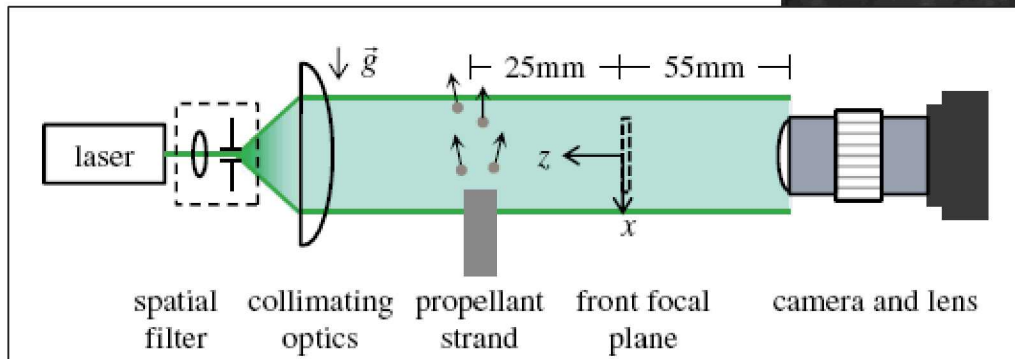

# Metalized Propellant Combustion

## Metalized Propellant is Challenging!

- ns CARS measurements did not work
  - Metal particle induced breakdown
  - High nonresonant background levels
  - Similar to breakdown in coal combustion!

## Advantages of fs/ps CARS

- fs/ps Pulse energies much less than with ns lasers
  - Less chance of breakdown
- Nonresonant background decays quickly after pump pulse
  - Avoid nonresonant background via probe time delays

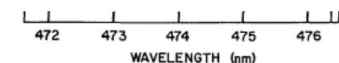
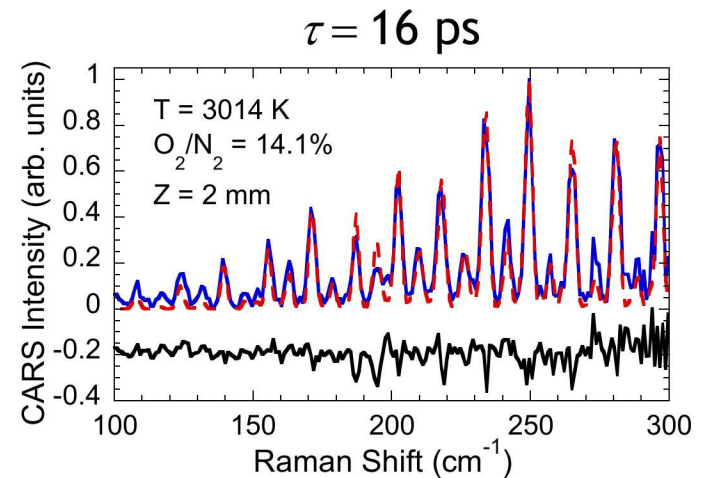
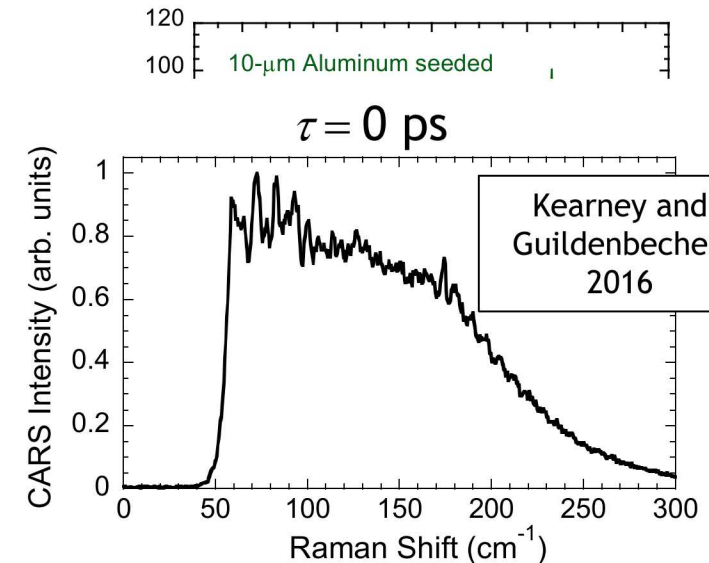

# N<sub>2</sub> Rotational fs/ps CARS

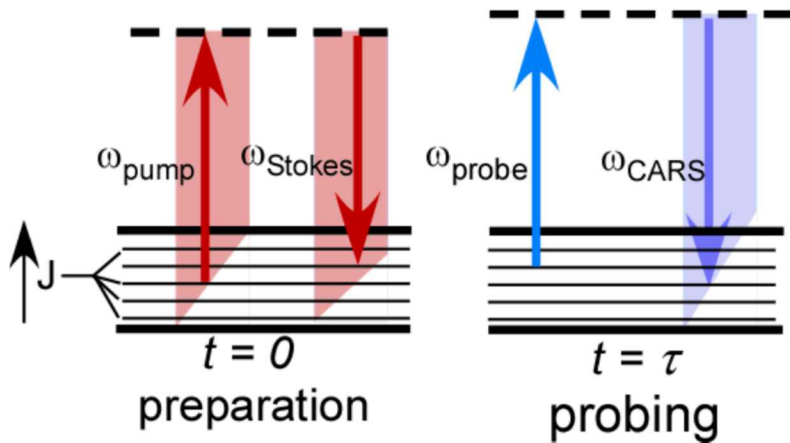

## Second harmonic bandwidth compressor:

- 800-nm fs pulses to 400-nm ps pulses
- Split input, apply equal and opposite chirp, then sum-frequency-mixing
- 35-50% efficient
- 400-nm bandwidth < 3.5 cm<sup>-1</sup>

$$E_{\text{CARS}}(t - \tau) = E_{\text{probe}}(t - \tau) \times \chi(t)$$

$$\chi = \sum_J W_J \exp(i \omega_J t)$$

$$W_J = X \gamma^2 b_{JJ'} (N_{J'} - N_J)$$

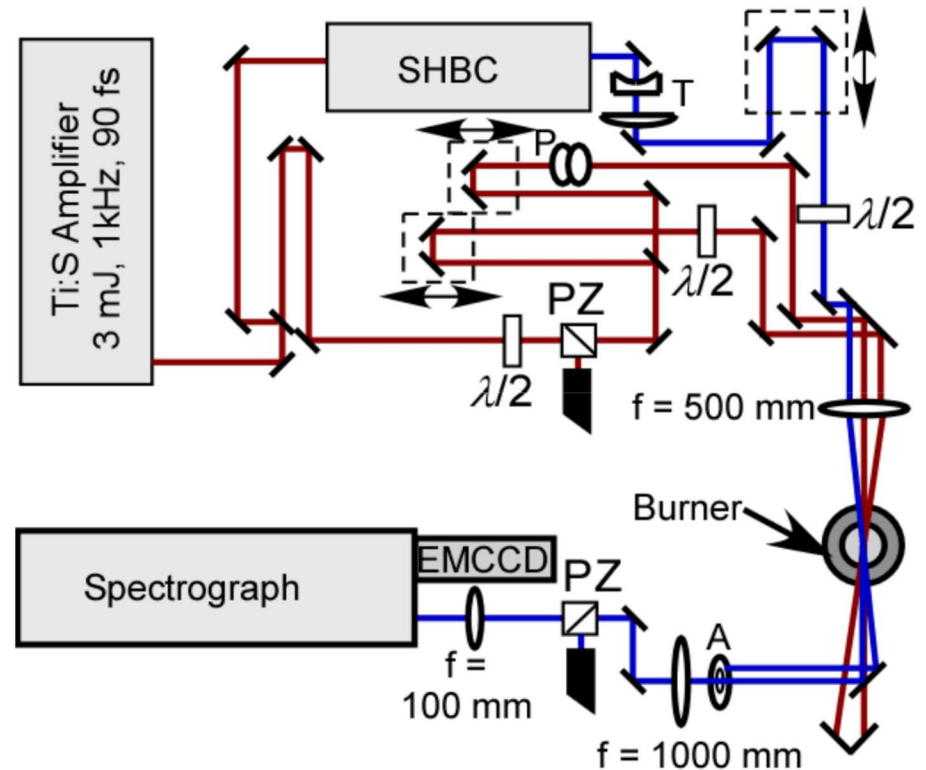

# 9 Results: N<sub>2</sub> Rotational fs/ps CARS

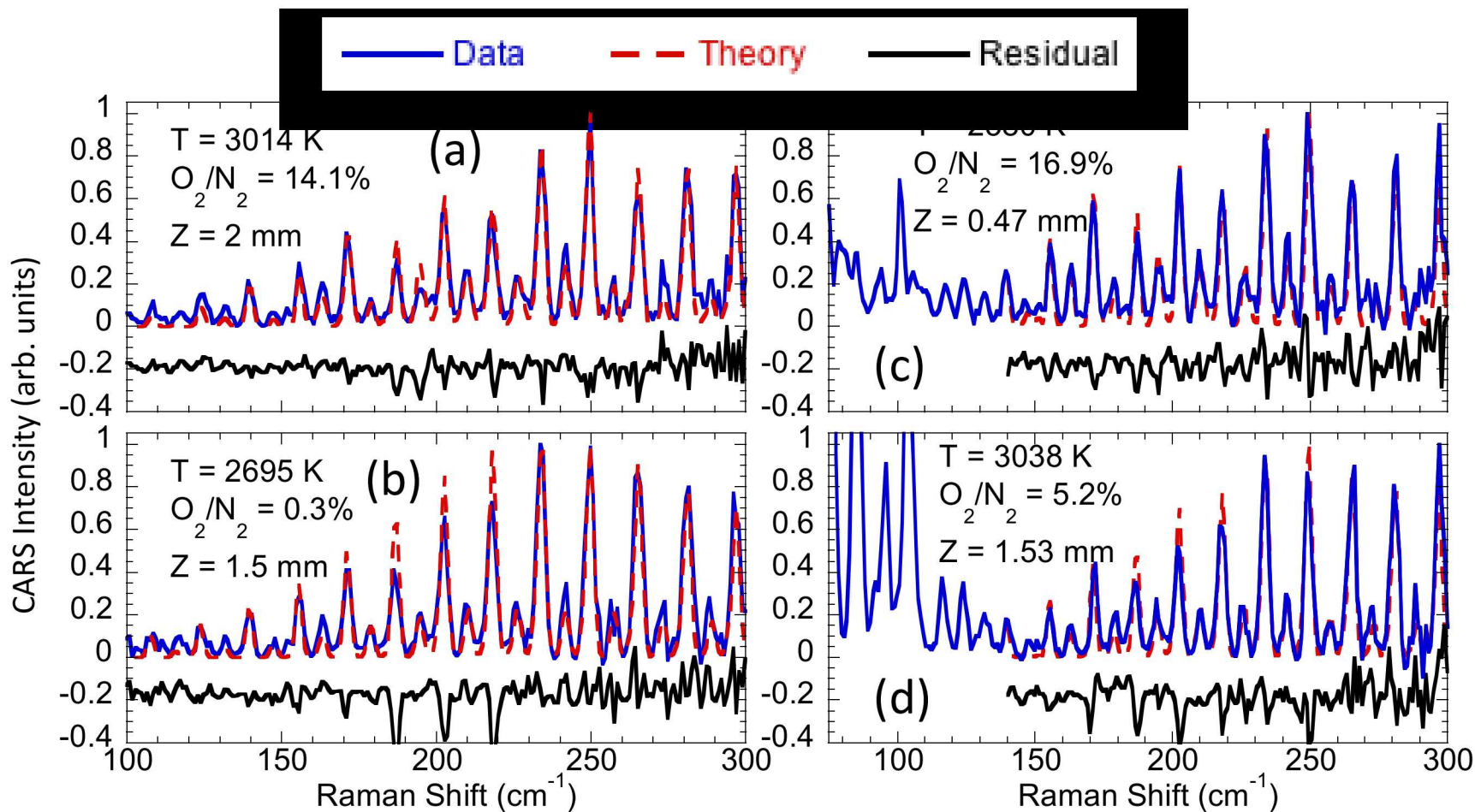

# N<sub>2</sub> Rotational fs/ps CARS

## Results

- CARS measurements performed within 3 mm of propellant surface
- No breakdown, nonresonant background or loss of resonant Raman signal
- Spectra dominated by N<sub>2</sub> and O<sub>2</sub> contributions
  - Cl<sub>2</sub>; HCl; NO; NO<sub>2</sub> also present
- Temperature and N<sub>2</sub>/O<sub>2</sub> ratio close to adiabatic equilibrium

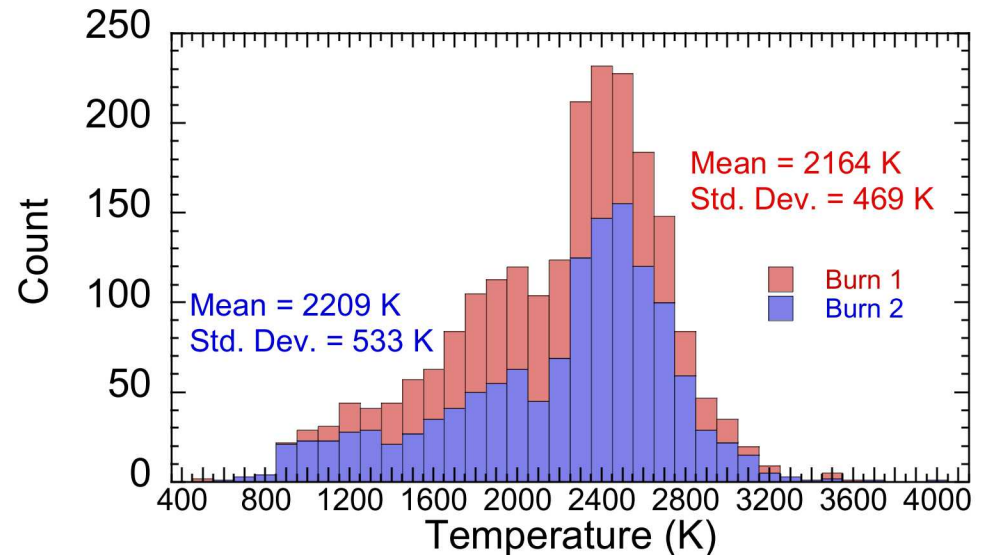
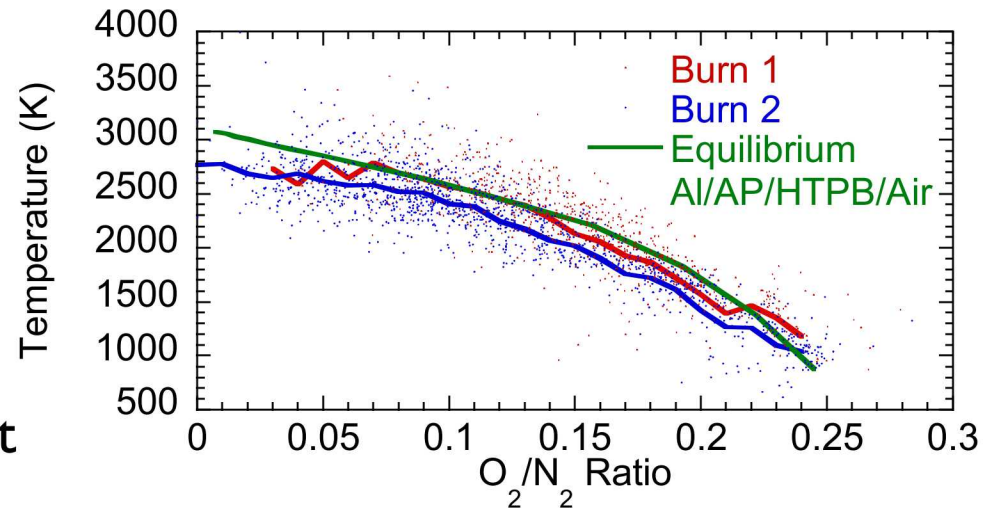

# Future Work: H<sub>2</sub> Vibrational fs/ps CARS

## Future Improvements

- Switch to vibrational CARS for better temperature sensitivity
- Tunable vibrational excitation to H<sub>2</sub>, CO, or other species
- Reduce probe volume size

## H<sub>2</sub> ns CARS

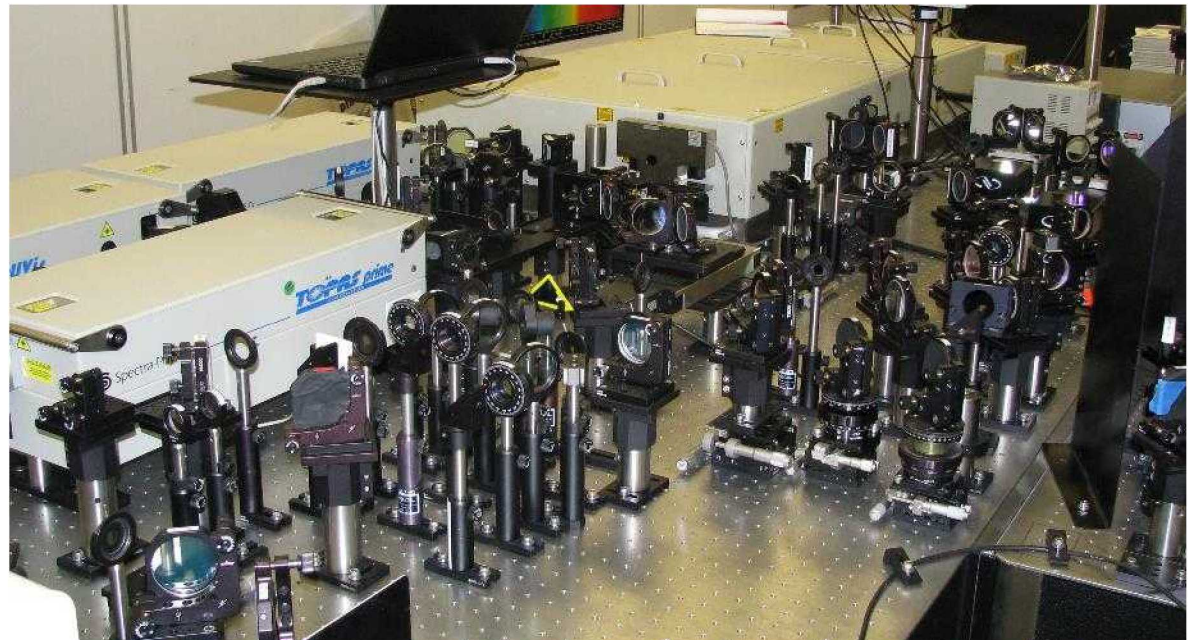
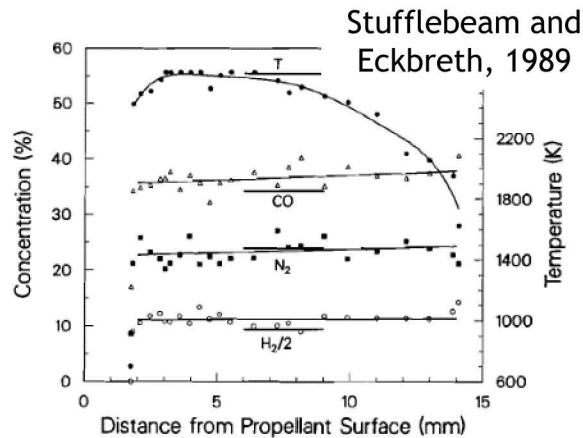
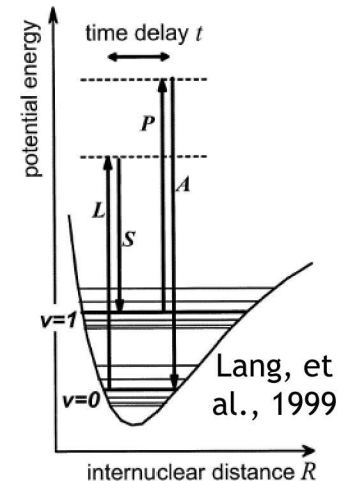
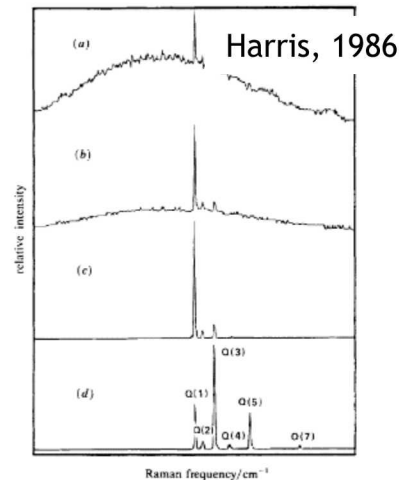

- Beckstead, M.W., Puduppakkam, K., Thakre, P. and Yang, V., 2007. Modeling of combustion and ignition of solid-propellant ingredients. *Progress in Energy and Combustion Science*, 33(6), pp.497-551.
- Edwards, T., Weaver, D.P., Campbell, D.H. and Hulsizer, S., 1986. Investigation of high pressure solid propellant combustion chemistry using emission spectroscopy. *Journal of Propulsion and Power*, 2(3), pp.228-234.
- Parr, T.P. and Hanson-Parr, D.M., 1996, January. Solid propellant diffusion flame structure. In *Symposium (International) on Combustion* (Vol. 26, No. 2, pp. 1981-1987). Elsevier.
- Edwards, T., Weaver, D.P. and Campbell, D.H., 1987. Laser-induced fluorescence in high pressure solid propellant flames. *Applied optics*, 26(17), pp.3496-3509.
- Korobeinichev, O.P., Kuibida, L.V., Paletsky, A.A. and Chernov, A.A., 1996. Study of solid propellant flame structure by mass-spectrometric sampling. *Combustion science and technology*, 113(1), pp.557-571.
- Harris, L.E., 1986. Hydrogen coherent anti-Stokes Raman spectra from CH<sub>4</sub>-N<sub>2</sub>O and nitramine composite flames. *Journal of the Chemical Society, Faraday Transactions 2: Molecular and Chemical Physics*, 82(12), pp.2129-2141.
- Stufflebeam, J.H. and Eckbreth, A.C., 1989. CARS diagnostics of solid propellant combustion at elevated pressure. *Combustion science and technology*, 66(4-6), pp.163-179.
- Guildenbecher, D.R., Cooper, M.A., Gill, W., Stauffacher, H.L., Oliver, M.S. and Grasser, T.W., 2014. Quantitative, three-dimensional imaging of aluminum drop combustion in solid propellant plumes via digital in-line holography. *Optics letters*, 39(17), pp.5126-5129.
- Beiting, E.J., 1985. Coherent interference in multiplex CARS measurements: nonresonant susceptibility enhancement due to laser breakdown. *Applied optics*, 24(18), pp.3010-3017.
- Kearney, S.P. and Guildenbecher, D.R., 2016. Temperature measurements in metalized propellant combustion using hybrid fs/ps coherent anti-Stokes Raman scattering. *Applied optics*, 55(18), pp.4958-4966.
- Lang, T., Kompa, K.L. and Motzkus, M., 1999. Femtosecond CARS on H<sub>2</sub>. *Chemical physics letters*, 310(1-2), pp.65-72.