



2018 European Materials Research Society Spring Meeting

Modulation of two-dimensional hole gas density in an undoped Ge/GeSi heterostructure by Ion Implantation

Po-Yuan Chiu^{1,*}, Chia-You Liu¹, Yen Chuang¹, Charles Thomas Harris²,
Tzu-Ming Lu², and Jiun-Yun Li^{1,3,4}
*: [email: r06943181@ntu.edu.tw](mailto:r06943181@ntu.edu.tw)

¹ Graduate Institute of Electronics Engineering, National Taiwan University, Taipei 10617, Taiwan

² Sandia National Laboratories, Albuquerque, New Mexico 87185, USA

³ Department of Electrical Engineering, National Taiwan University, Taipei 10617, Taiwan

⁴ National Nano Device Laboratories, Hsinchu 30078, Taiwan

Outline

- Motivation
- Epitaxy and Material Analysis
- Device Fabrication
- Electrical Characteristics
- Summary

- Motivation
- Epitaxy and Material Analysis
- Device Fabrication
- Electrical Characteristics
- Summary

Motivation: Group-IV Spintronics



National
Taiwan
University

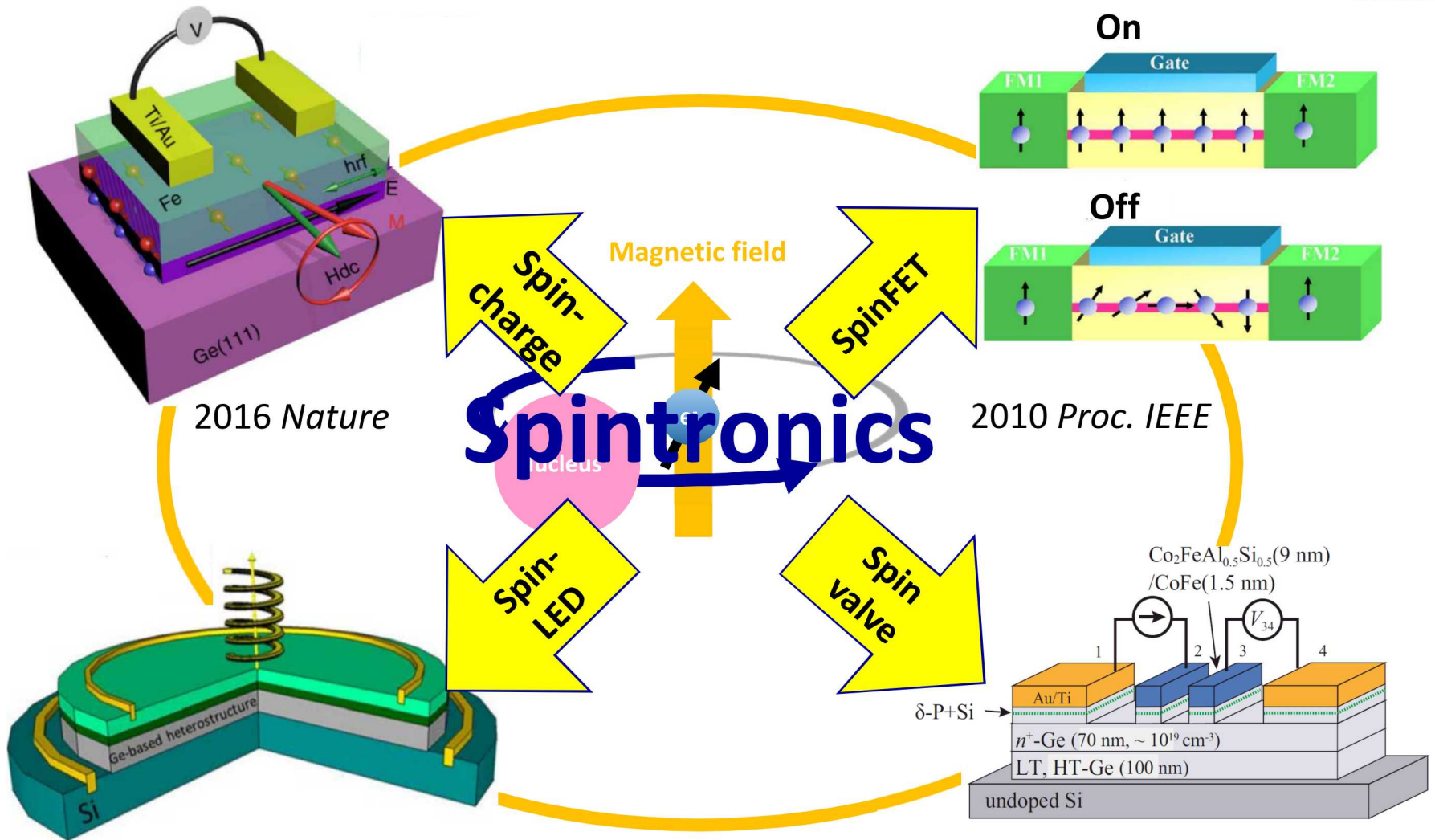

Motivation: Ge Two-Dimensional Hole Gas

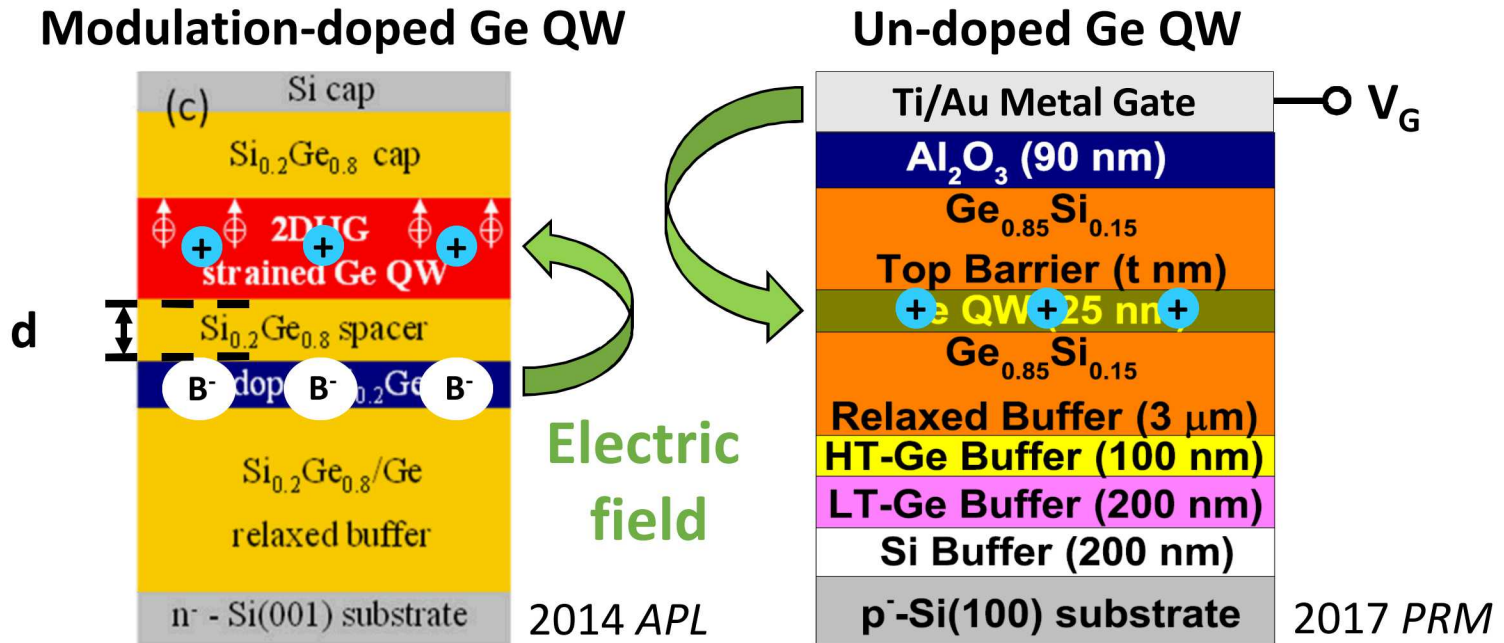

Structures	Modulating 2DHG	Disadvantage
Mod.-doped	Dopant density and distance (Regrow new epitaxial layer)	Impurity scattering → mobility ↓
Un-doped	Gate voltage V_G	Poor oxide/GeSi interface



Motivation: Ge Two-Dimensional Hole Gas

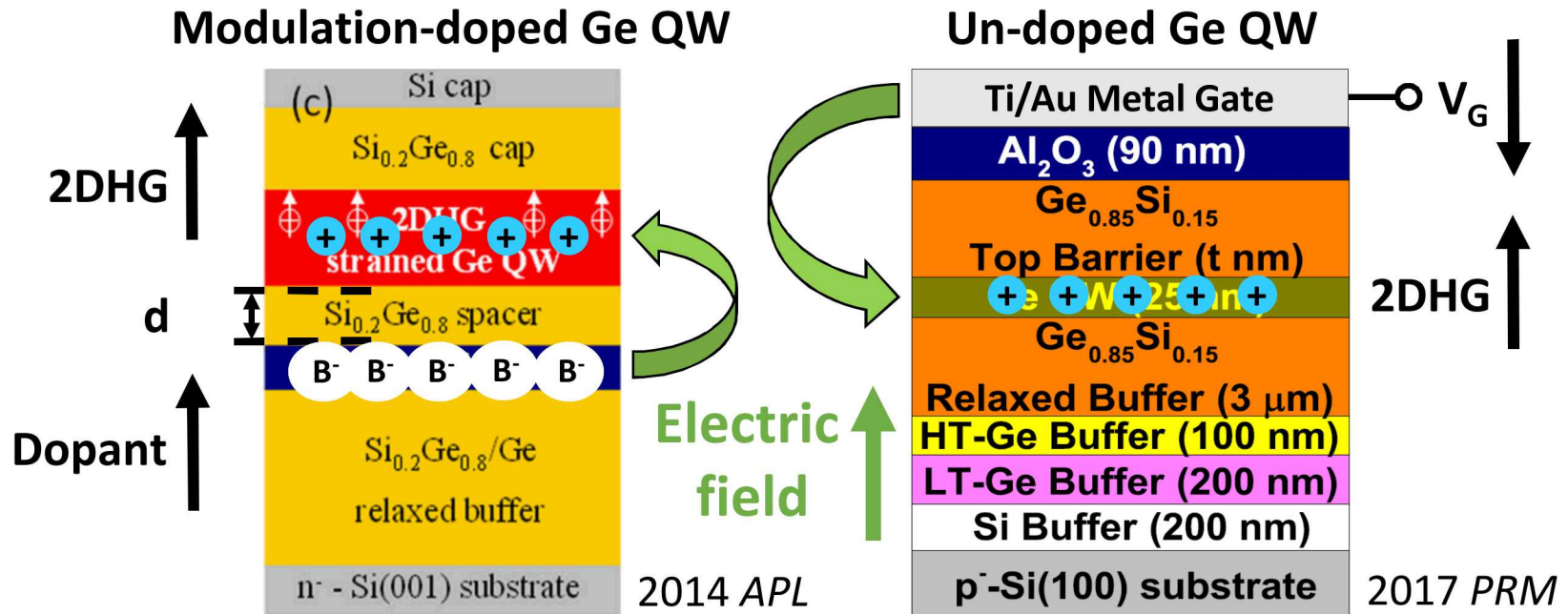

Structures	Modulating 2DHG	Disadvantage
Mod.-doped	Dopant density and distance (Regrow new epitaxial layer)	Impurity scattering → mobility ↓
Un-doped	Gate voltage V_G	Poor oxide/GeSi interface



Motivation: Ge Two-Dimensional Hole Gas

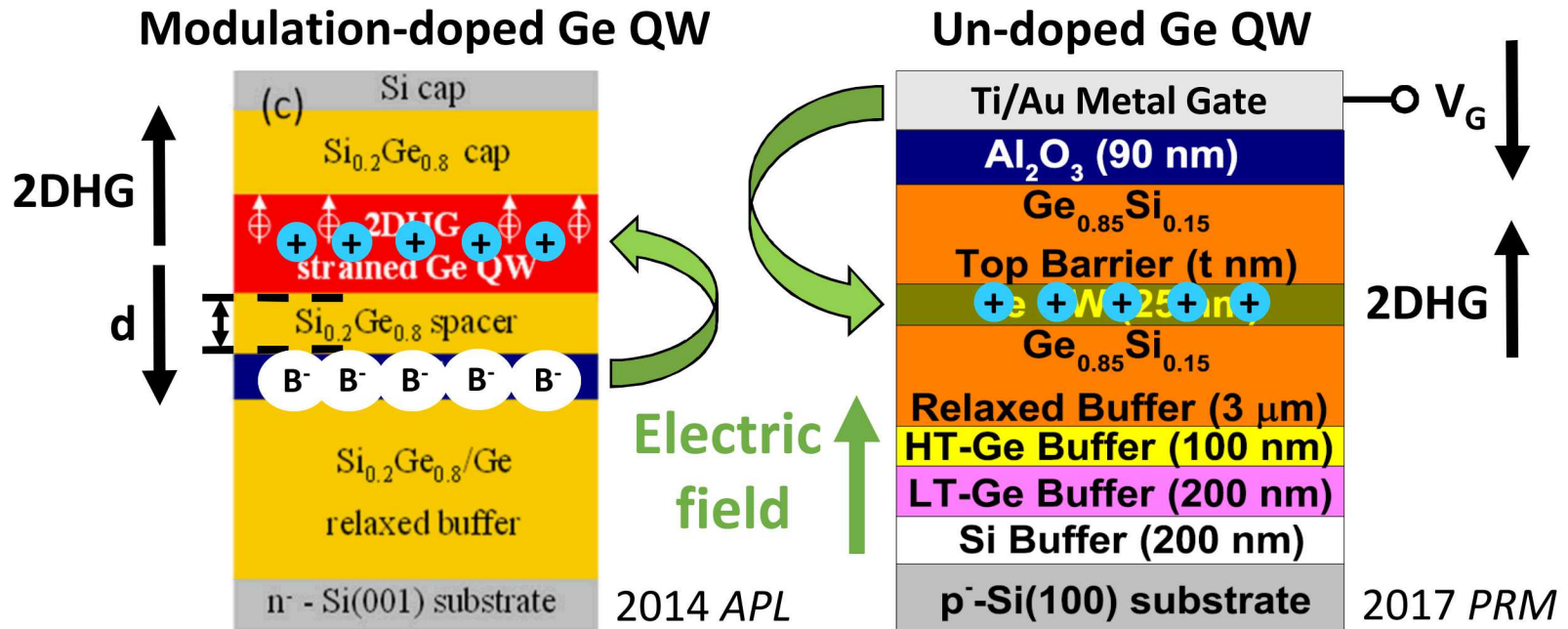

Structures	Modulating 2DHG	Disadvantage
Mod.-doped	Dopant density and distance (Regrow new epitaxial layer)	Impurity scattering → mobility ↓
Un-doped	Gate voltage V_G	Poor oxide/GeSi interface



Motivation: Ge Two-Dimensional Hole Gas

ion implantation for modulation doping

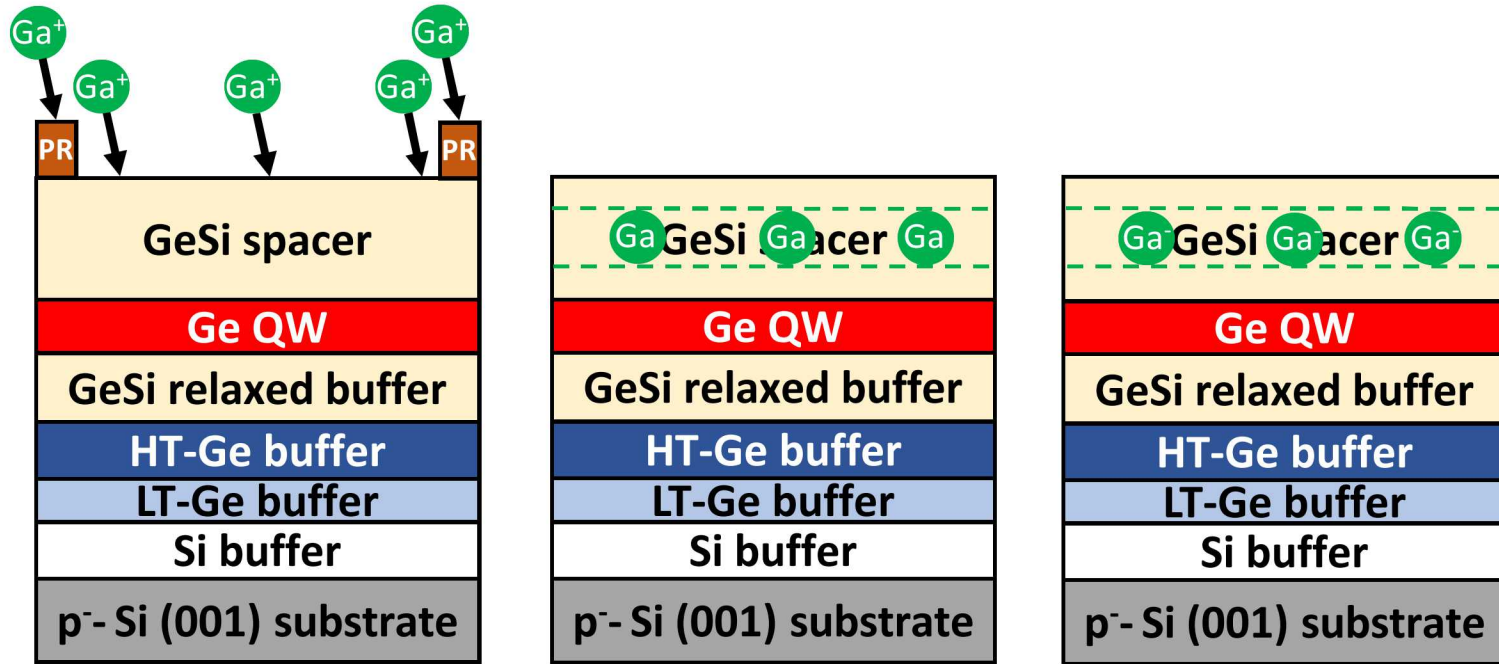

- Gallium ions were implanted into the GeSi top spacer.
- The 2DHG comes from the ex-situ doping layer.
- Modulate the carrier density by changing implantation fluence.

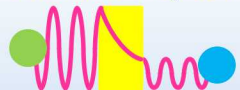

Motivation: Ge Two-Dimensional Hole Gas

ion implantation for modulation doping

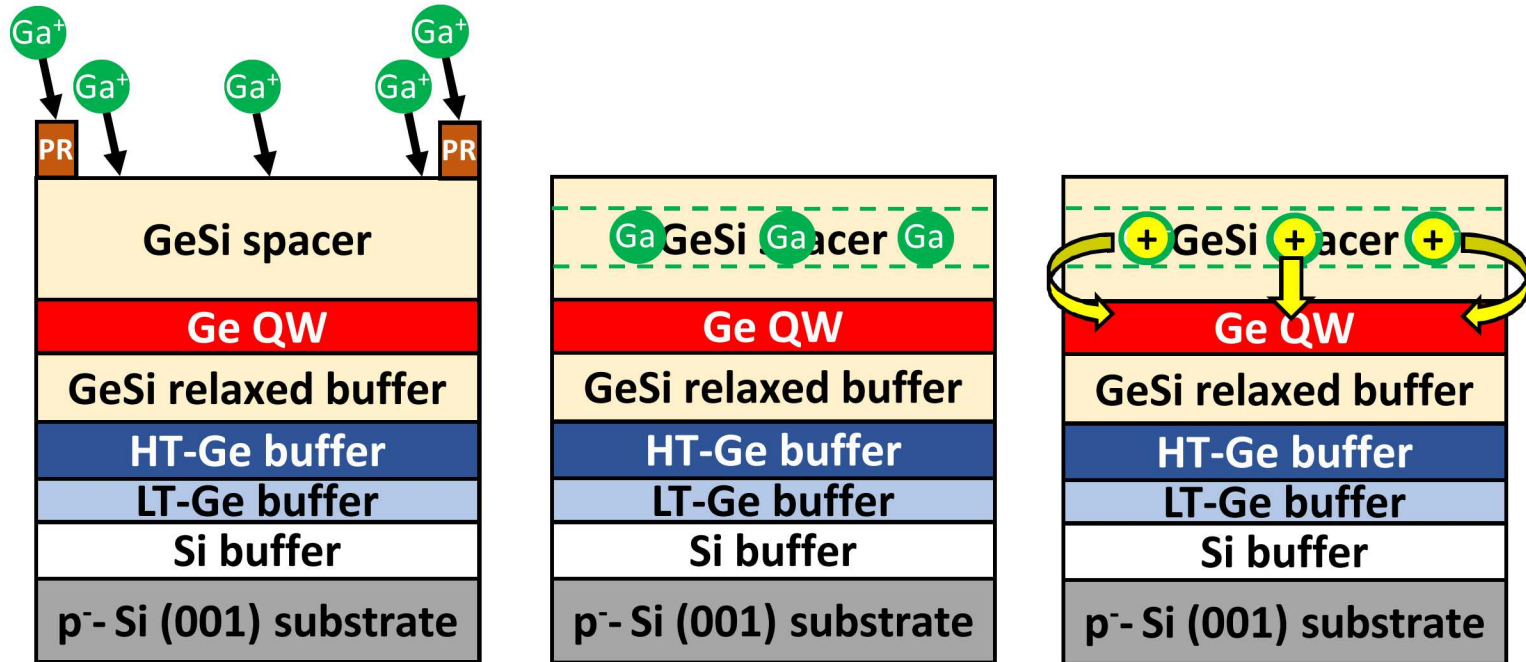

- Gallium ions were implanted into the GeSi top spacer.
- The 2DHG comes from the ex-situ doping layer.
- Modulate the carrier density by changing implantation fluence.

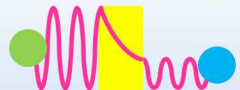

Motivation: Ge Two-Dimensional Hole Gas

ion implantation for modulation doping

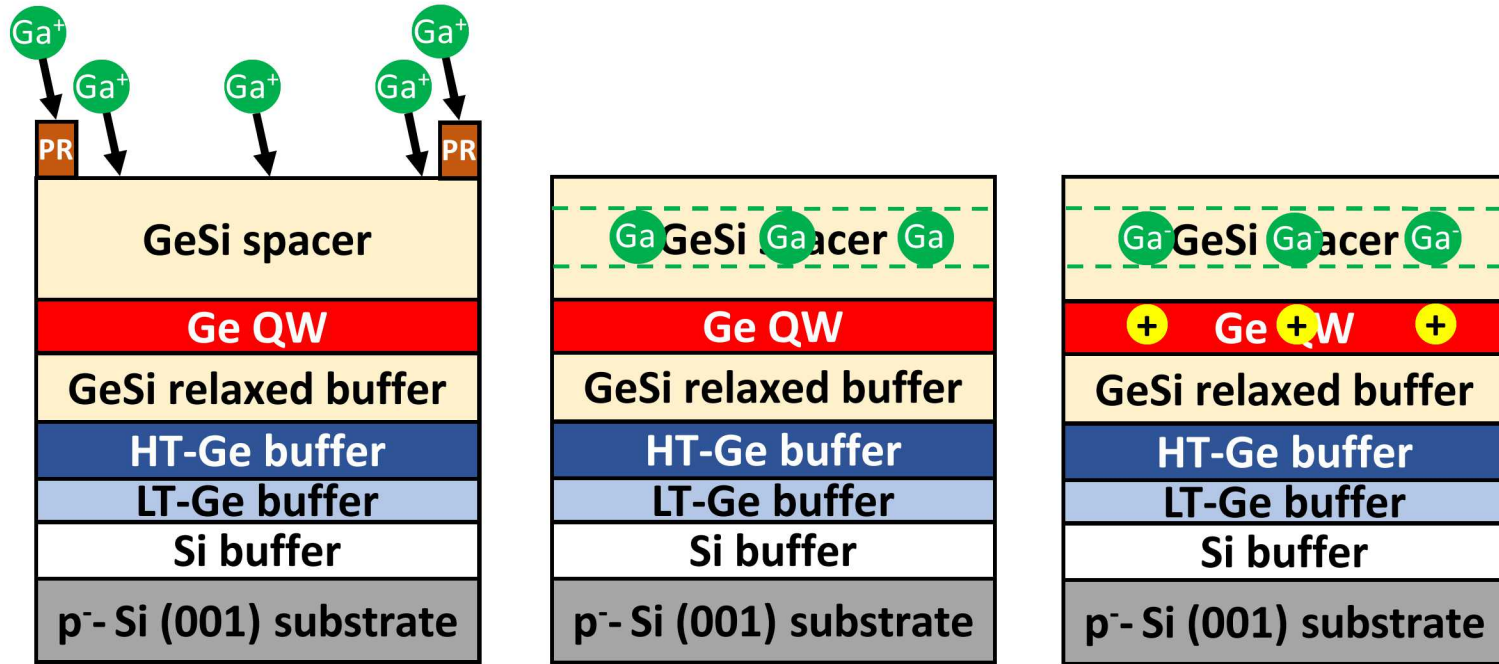

- Gallium ions were implanted into the GeSi top spacer.
- The 2DHG comes from the ex-situ doping layer.
- Modulate the carrier density by changing implantation fluence.



Motivation: Ge Two-Dimensional Hole Gas

ion implantation for modulation doping

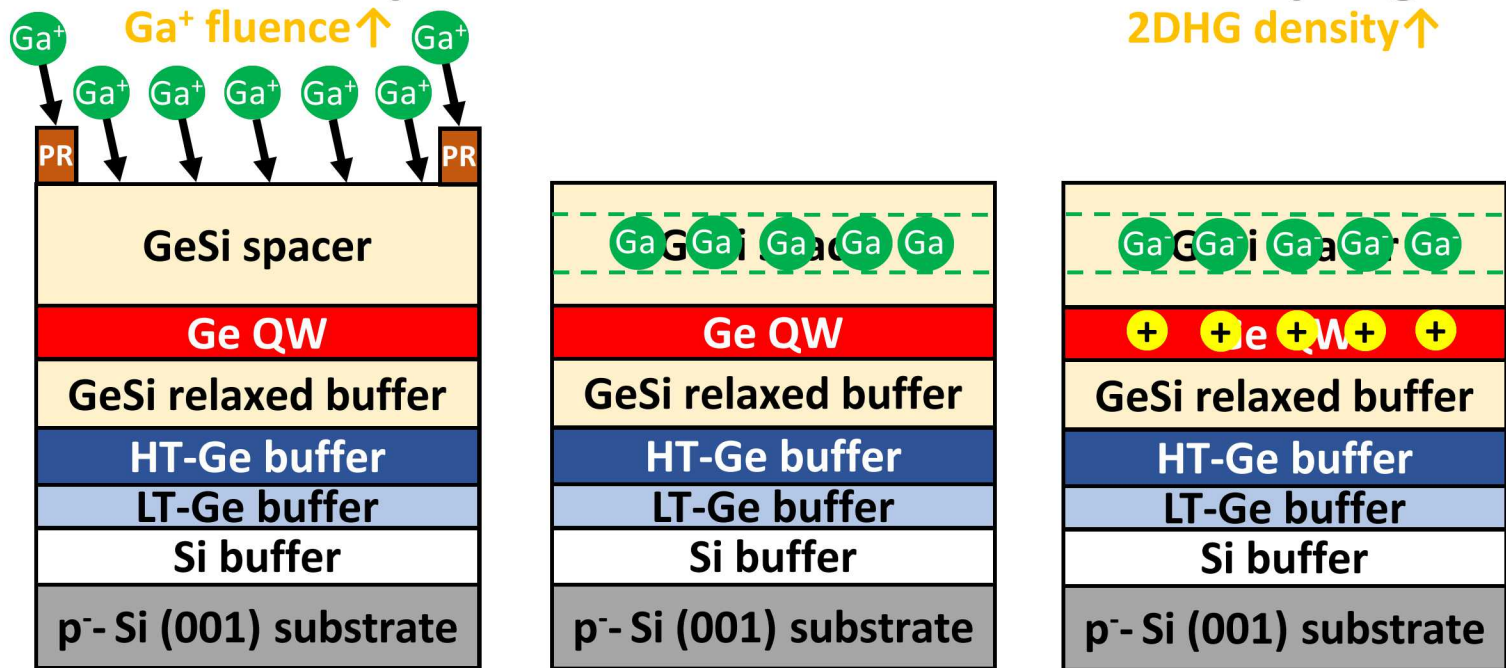

- Gallium ions were implanted into the GeSi top spacer.
- The 2DHG comes from the ex-situ doping layer.
- Modulate the carrier density by changing implantation fluence.

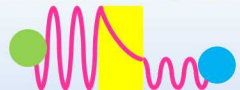

Outline

- Motivation
- **Epitaxy and Material Analysis**
- Device Fabrication
- Electrical Characteristics
- Summary



Epitaxy Structure before Ion Implantation

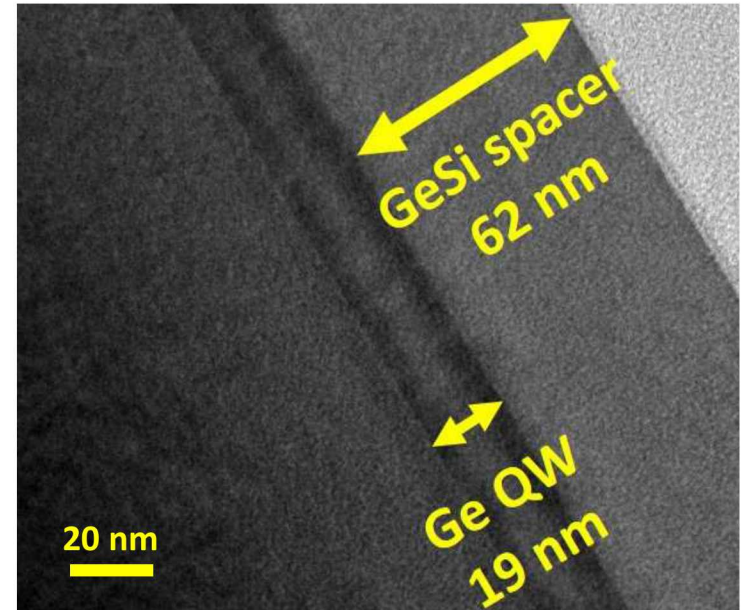
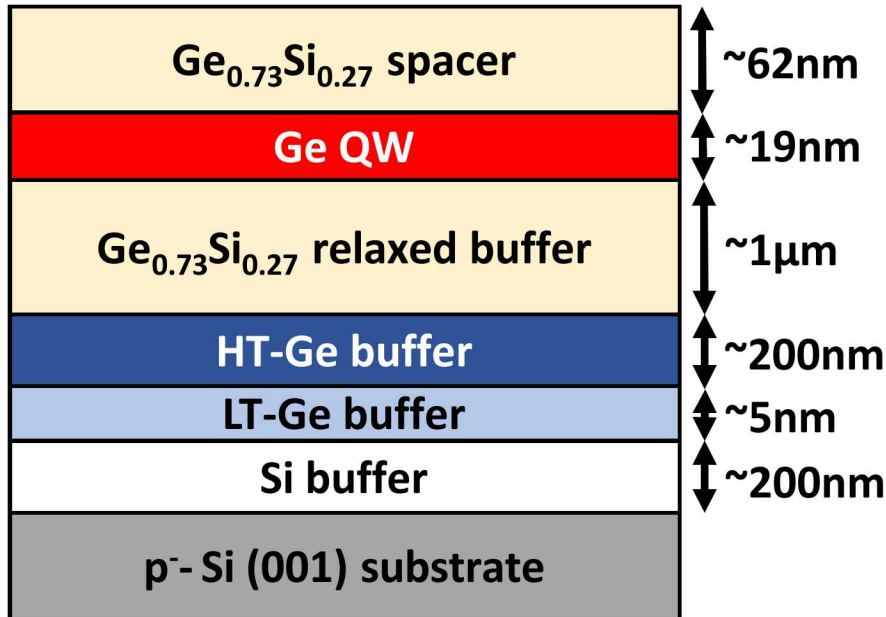

- Reduced pressure chemical vapor deposition (RPCVD)
- Precursor: germane (GeH₄) and silane (SiH₄) at 450°C
- XTEM => no observable threading dislocation ($\leq 10^6 \text{ cm}^{-2}$)

Depth Profile and Strain Condition before Ion Implantation

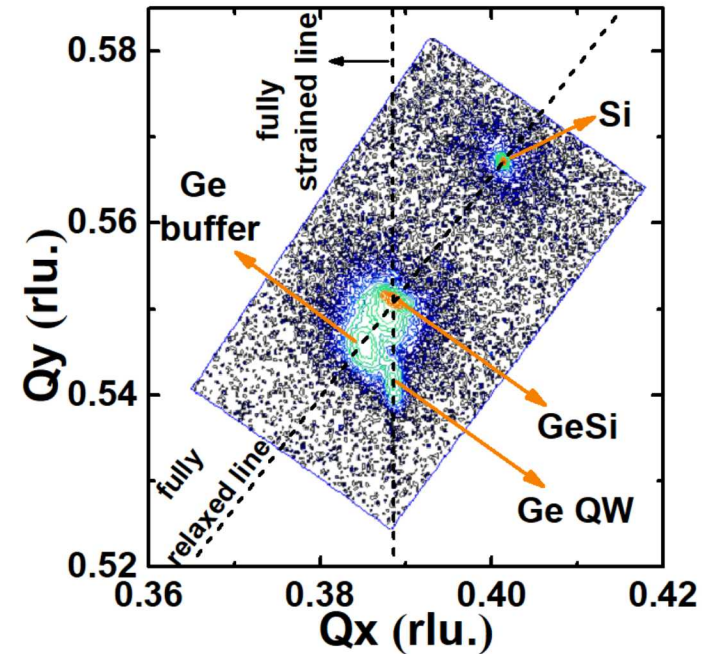
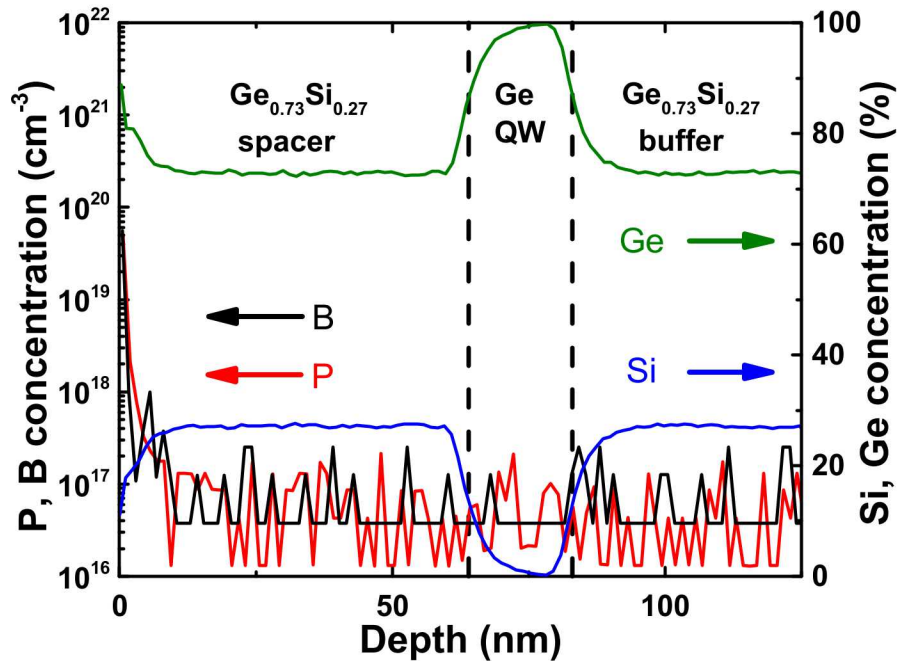

- SIMS: $[\text{Ge}]=73\%$, $[\text{Si}]=27\%$ in GeSi buffer layer
- Boron, phosphorous: detection limit ($< 5 \times 10^{16} \text{ cm}^{-3}$)
- Fully relaxed GeSi buffer layer and fully strained Ge QW layer

Outline

- Motivation
- Epitaxy and Material Analysis
- **Device Fabrication**
- Electrical Characteristics
- Summary

Device Fabrication for Electrical Characteristics

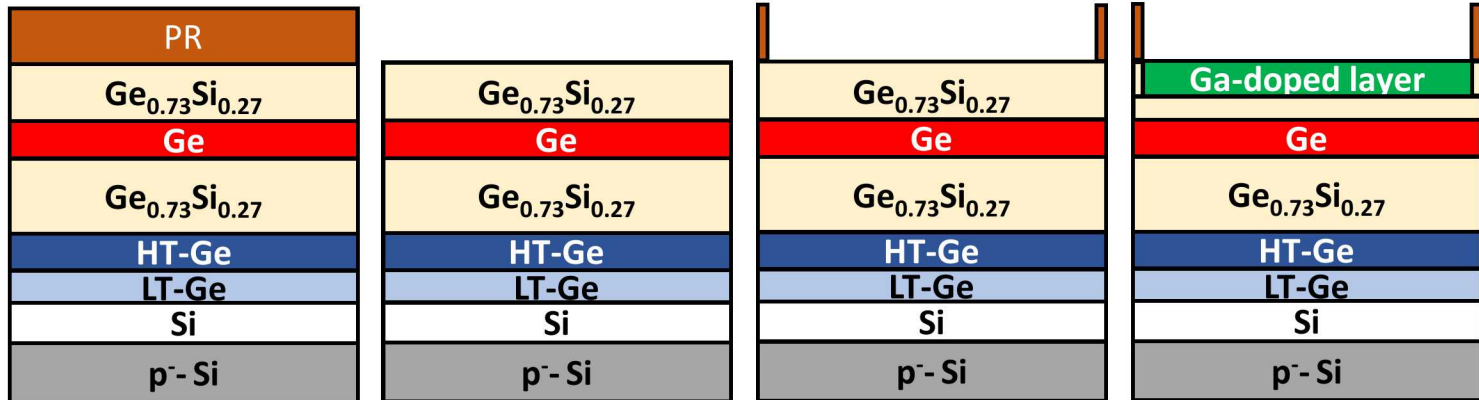
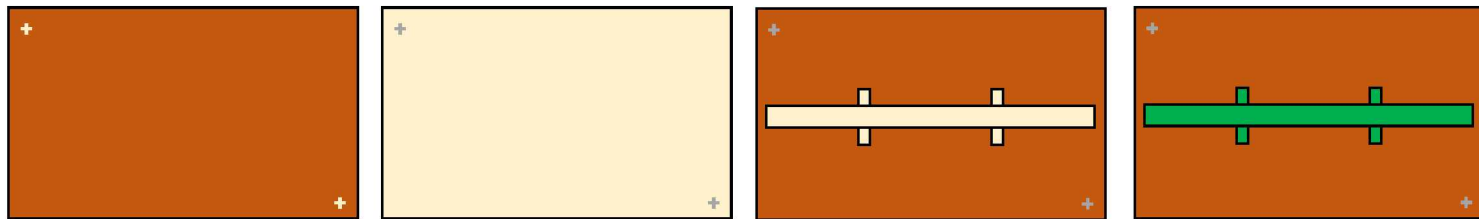

Defining
alignment mark

Reactive ion
etching

Defining
channel region

Ga ion
implantation

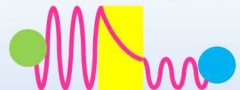

Device Fabrication for Electrical Characteristics

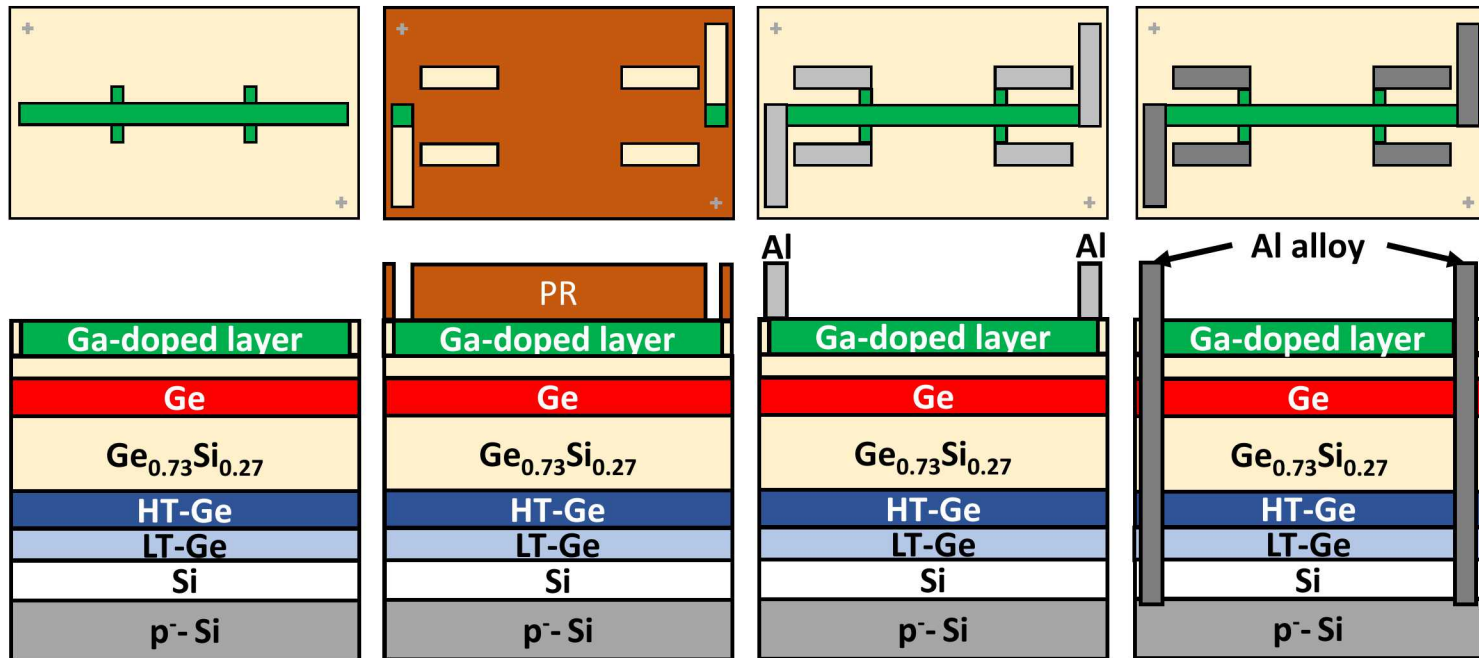

Rapid thermal
annealing
(550°C, 1 hr)

Defining
contact region

Al deposition
(250 nm)

Rapid thermal
annealing
(490°C, 30 s)



Simulation of Gallium Implantation Profile

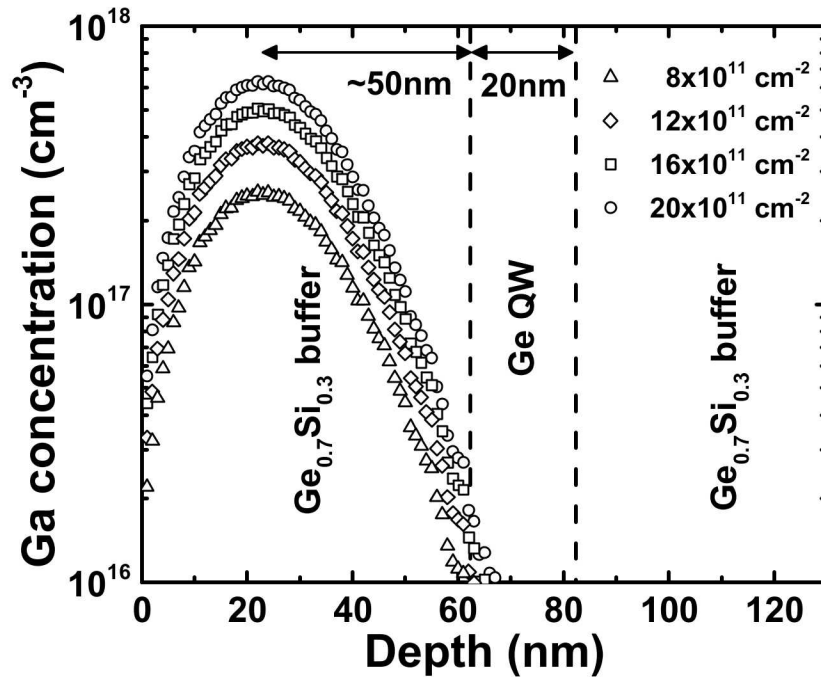

Sample number	Ion fluence (cm ⁻²)
1	8 x 10 ¹¹
2	12 x 10 ¹¹
3	16 x 10 ¹¹
4	20 x 10 ¹¹

Tilt=7° Energy=40 keV

- Distance between gallium (Ga) peaks and QW ↑ (↓) → carrier in Ge QW ↓ (remote scattering ↑)
- Ga fluence ~ 10¹² cm⁻² → typical density of 2DHG



- Motivation
- Epitaxy and Material Analysis
- Device Fabrication
- **Electrical Characteristics**
- Summary

Hall measurement at 1.5 K

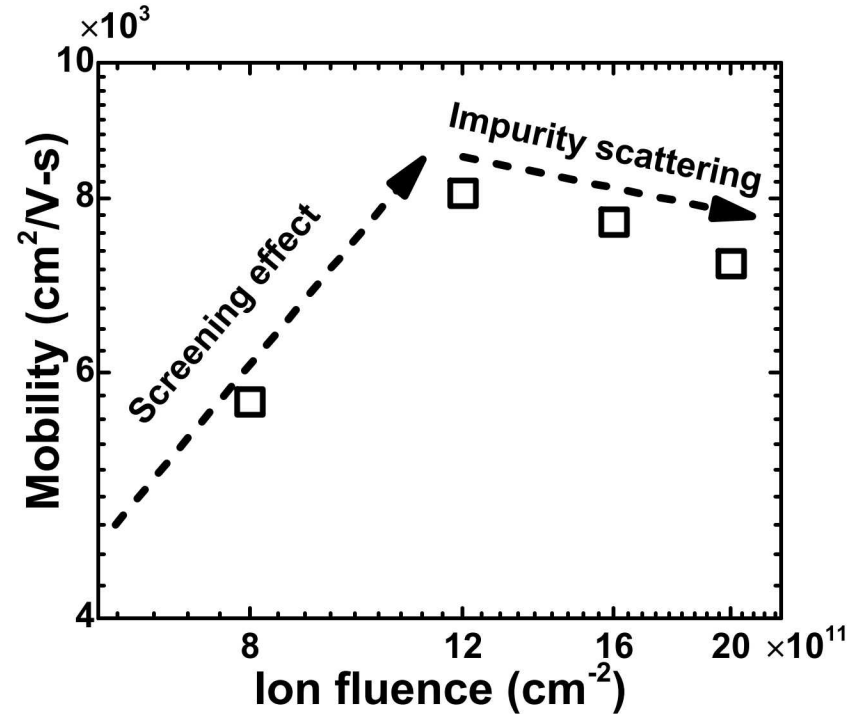
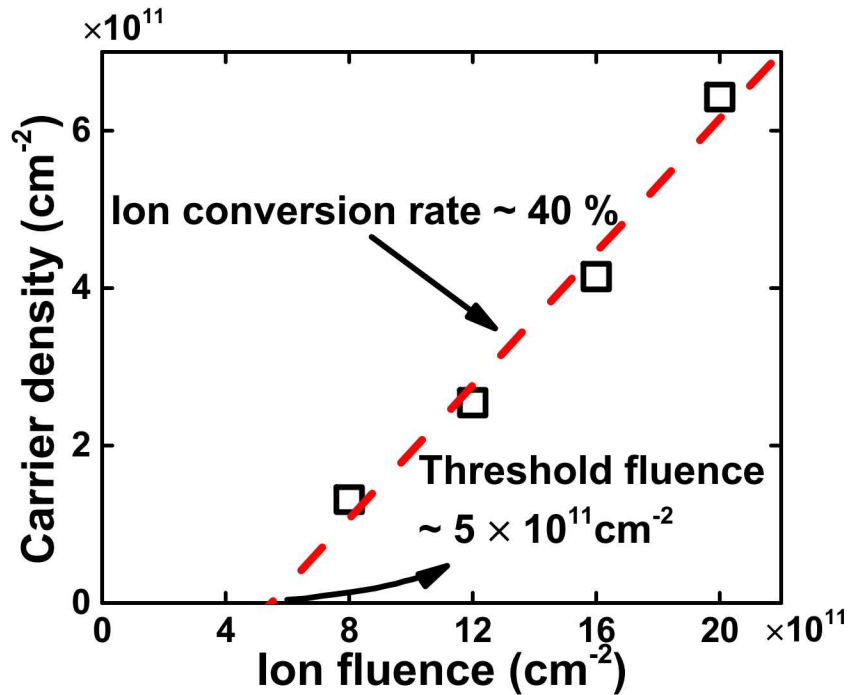

- The carrier density is linear to ion fluence.
- Ion fluence $< 12 \times 10^{11} \text{cm}^{-2}$ \rightarrow screening effect dominate;
 $> 12 \times 10^{11} \text{cm}^{-2}$ \rightarrow impurity scattering dominate.



Quantum Hall effect and Shubnikov de-Hass (SdH) Oscillations

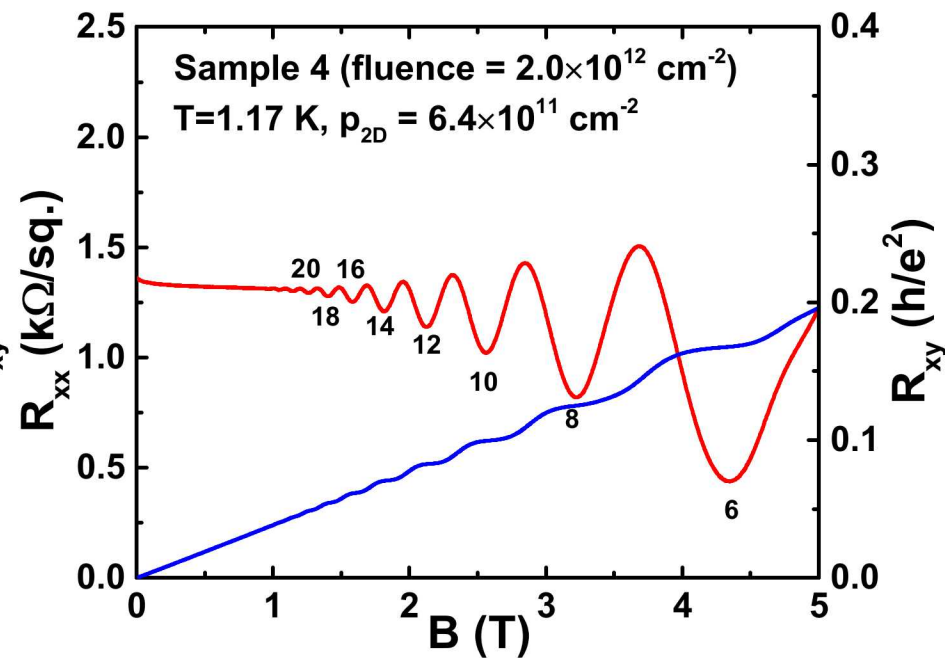
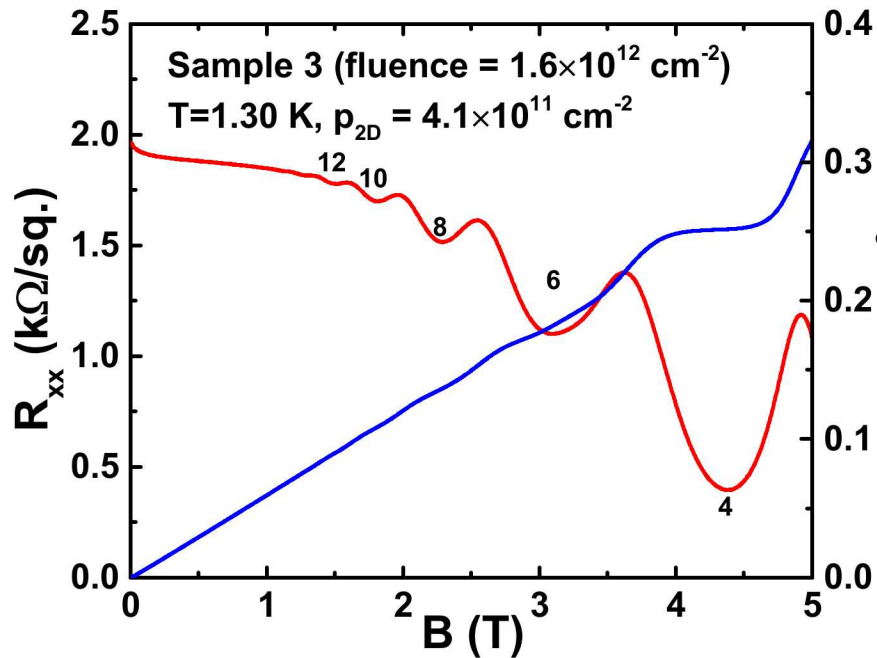

- Quantum Hall plateau \rightarrow 2D carriers
- The SdH oscillations are more obvious in sample 4.
- Fluence $\uparrow \rightarrow$ carrier $\uparrow \rightarrow$ filling factor \uparrow



Temperature Dependence of SdH Oscillations

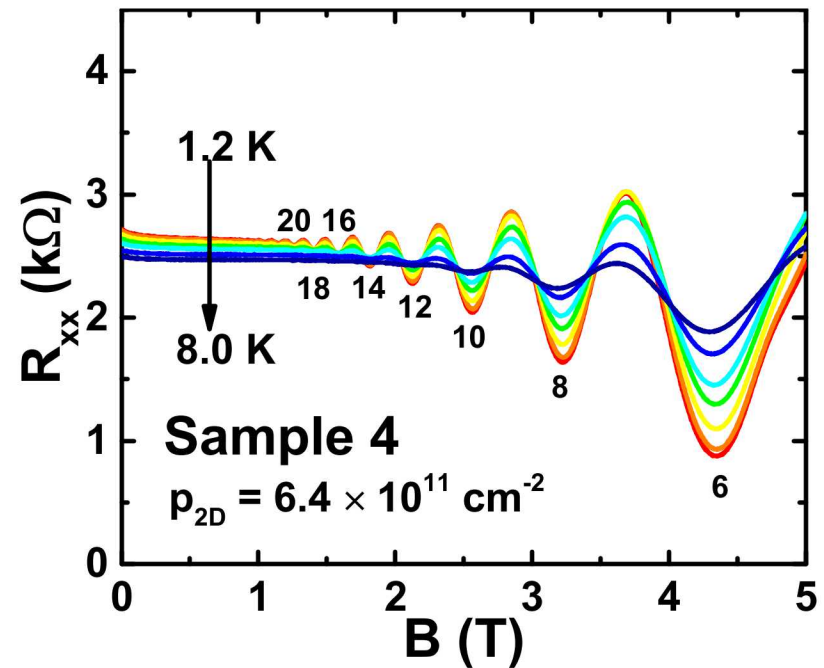
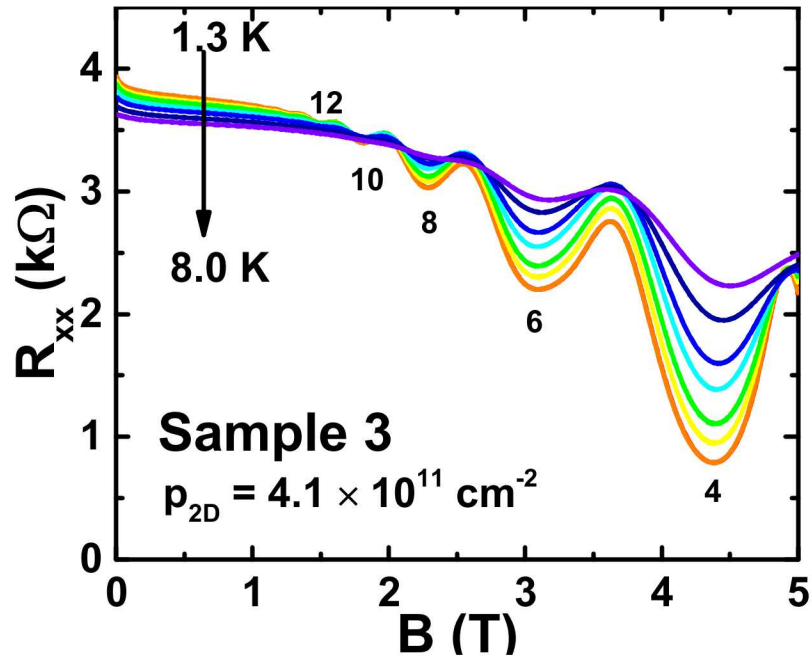

- Effective mass can be extracted from the temperature-dependent SdH oscillations.
- Well-resolved SdH oscillations → good sample quality

Effective Mass

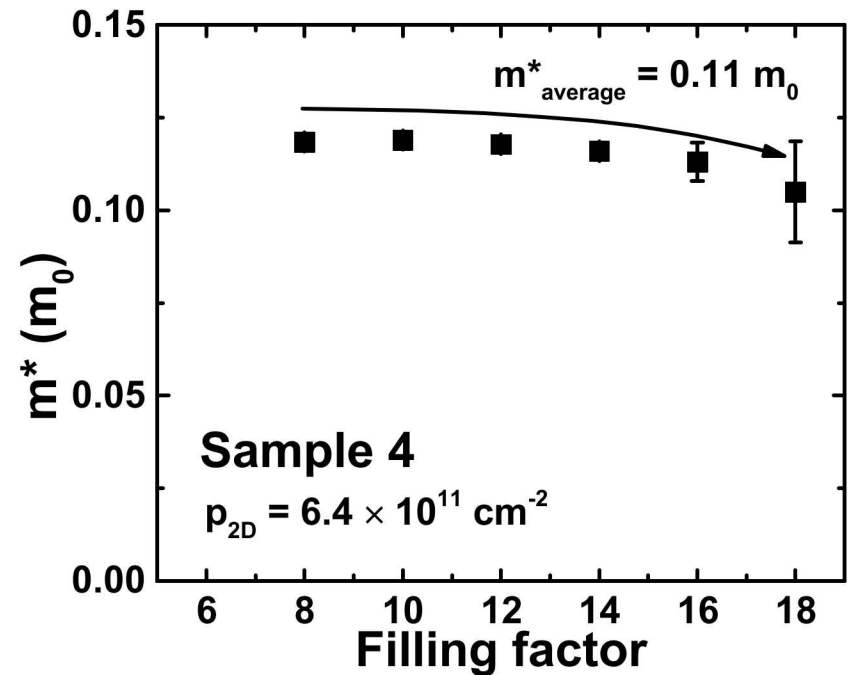
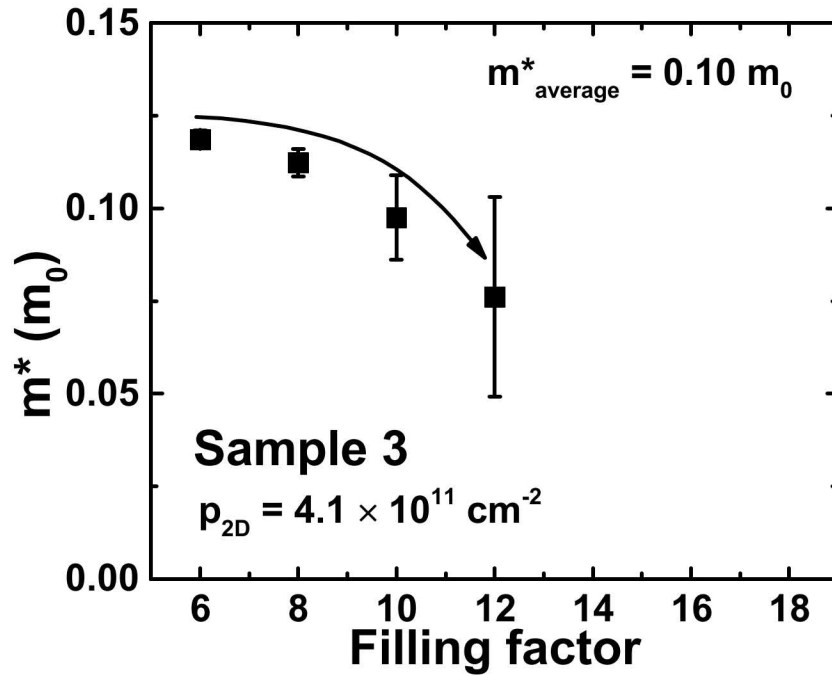

- Magnetic field dependence of effective mass (?)
- Slightly density dependence of effective mass
 - Non-parabolic valence band structure (?)

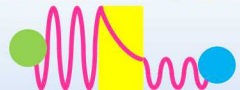

Summary

- Ga ion implantation to realize modulation-doped Ge 2DHG in an undoped Ge/GeSi heterostructure.
- 40 % activation rates of implanted Ga ions were achieved with carrier density of $1.3 \sim 6.4 \times 10^{11} \text{ cm}^{-2}$ and maximum mobility of $8,000 \text{ cm}^2/\text{V}\cdot\text{s}$.
- Well-resolved SdH oscillations and quantum Hall plateaus were observed with effective masses extracted ($m^* \sim 0.11 m_0$).

Acknowledgement

- This work at National Taiwan University has been supported by the Ministry of Science and Technology (106-2112-M-002-009-).
- This work has been supported by the Division of Materials Sciences and Engineering, Office of Basic Energy Sciences, U.S. Department of Energy (DOE). This work was performed, in part, at the Center for Integrated Nanotechnologies, a U.S. DOE, Office of Basic Energy Sciences, user facility. Sandia National Laboratories is a multi-mission laboratory managed and operated by National Technology and Engineering Solutions of Sandia, LLC., a wholly owned subsidiary of Honeywell International, Inc., for the U.S. Department of Energy's National Nuclear Security Administration under contract DE-NA-0003525. The views expressed in the article do not necessarily represent the views of the U.S. Department of Energy or the United States Government.