

# Long wave infrared spectropolarimetric directional reflectometer

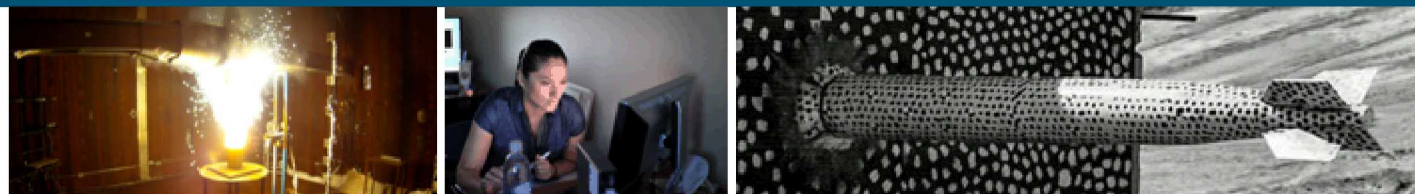

## PRESENTED BY

Charles F. LaCasse, Kyle H. Fuerschbach, Julia M. Craven, Jacob W. Segal, John D. van der Laan, Jeremy B. Wright, Steven M. Grover, Jessica M. Pehr, Thomas A. Reichardt, Thomas J. Kulp



Sandia National Laboratories is a multi-mission laboratory managed and operated by National Technology & Engineering Solutions of Sandia, LLC, a wholly owned subsidiary of Honeywell International Inc., for the U.S. Department of Energy's National Nuclear Security Administration under contract DE-NA0003525.

# The Bidirectional Reflectance Distribution Function

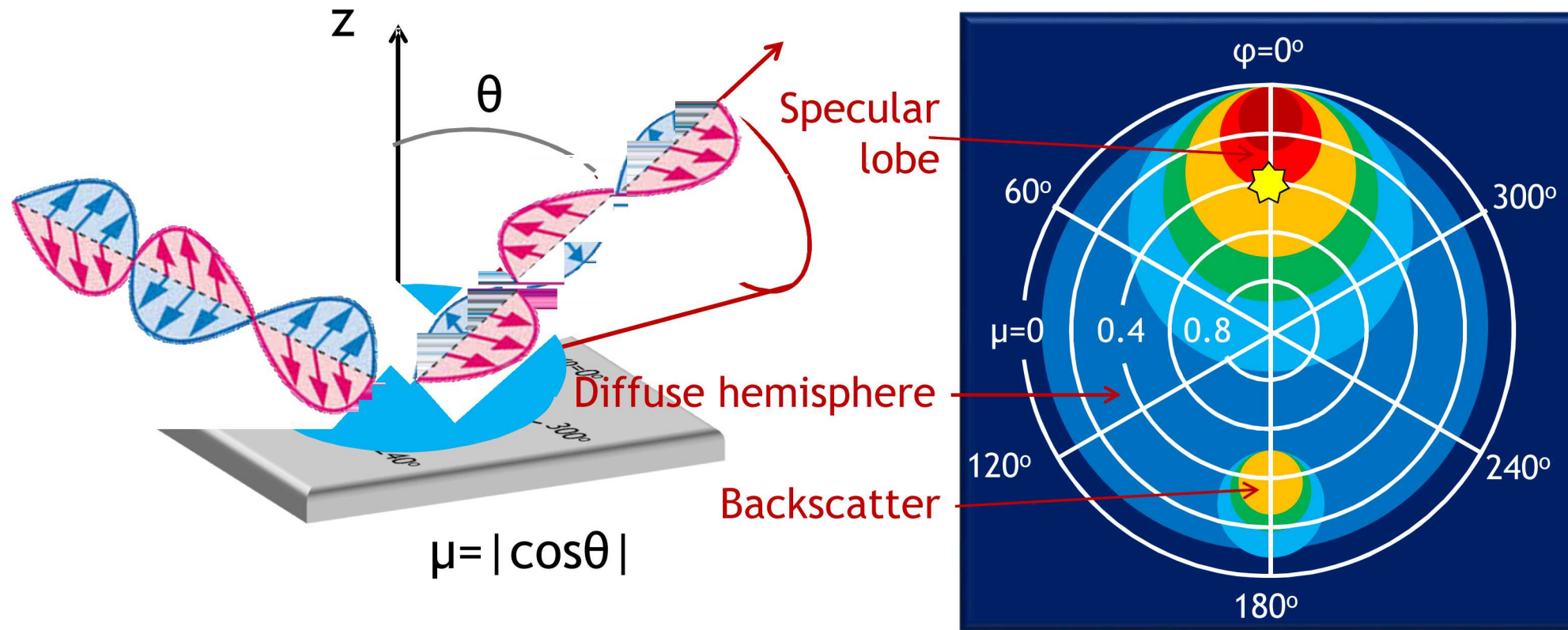

# Radiative-transfer model development

Goal: Improve interpretation of HSI data through use of radiative transfer model

Multi-lab team: PNNL, LANL, LLNL, SNL

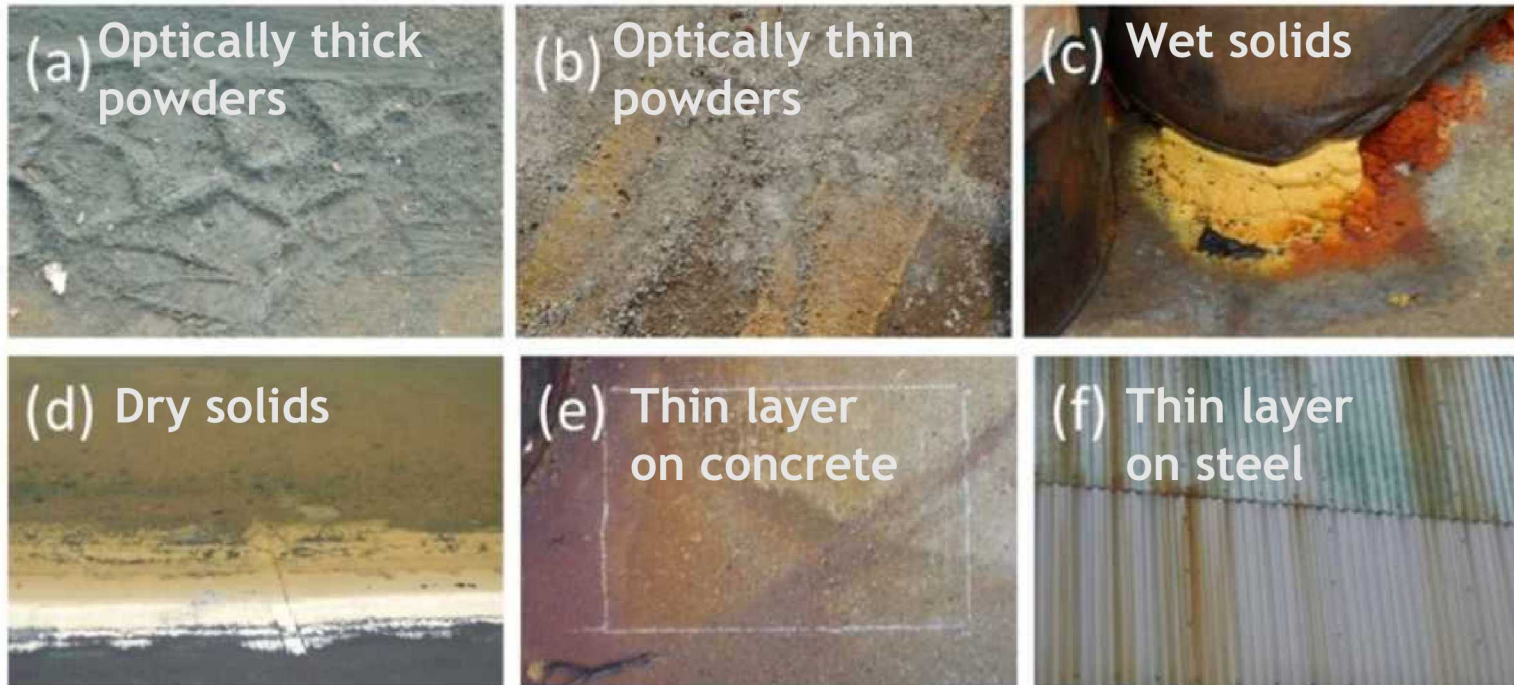

# Measurements to validate model

Observed spectra depend on both intrinsic material properties (i.e. complex index of refraction) and extrinsic material properties (surface morphology)

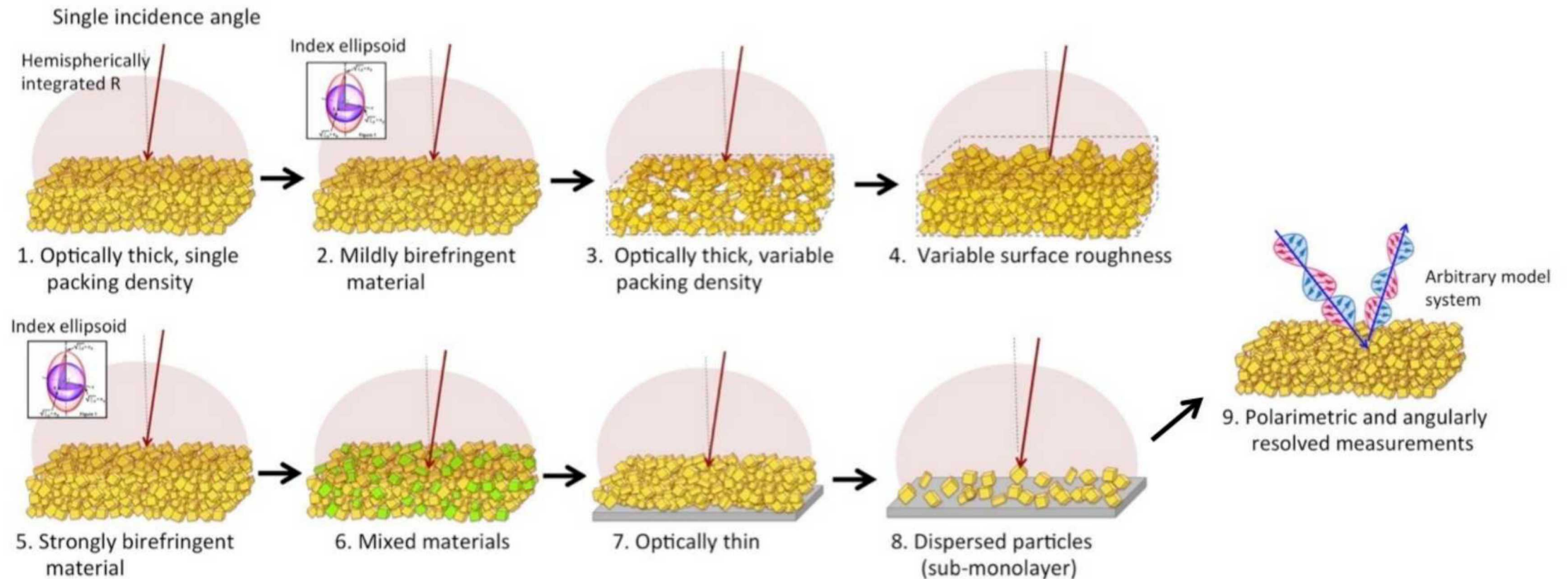

# Instrument concept

Goal: Measurements to support the modeling spiral

- Powder/liquid/film measurements
- Polarimetric measurements
- Spectrally resolved measurements
- LWIR is priority
- Want capability to measure all 4 angles of BRDF to study asymmetric samples



# Design Issues

## Low signal

- Small collection aperture, polarizer loss, blackbody source

## Arm length determines occluded angles

## Polarizer optics are mounted at the base of the periscope

- Retardance from proprietary protected gold mirror coatings is unknown, must be measured

## Polarization optics limit spectral band

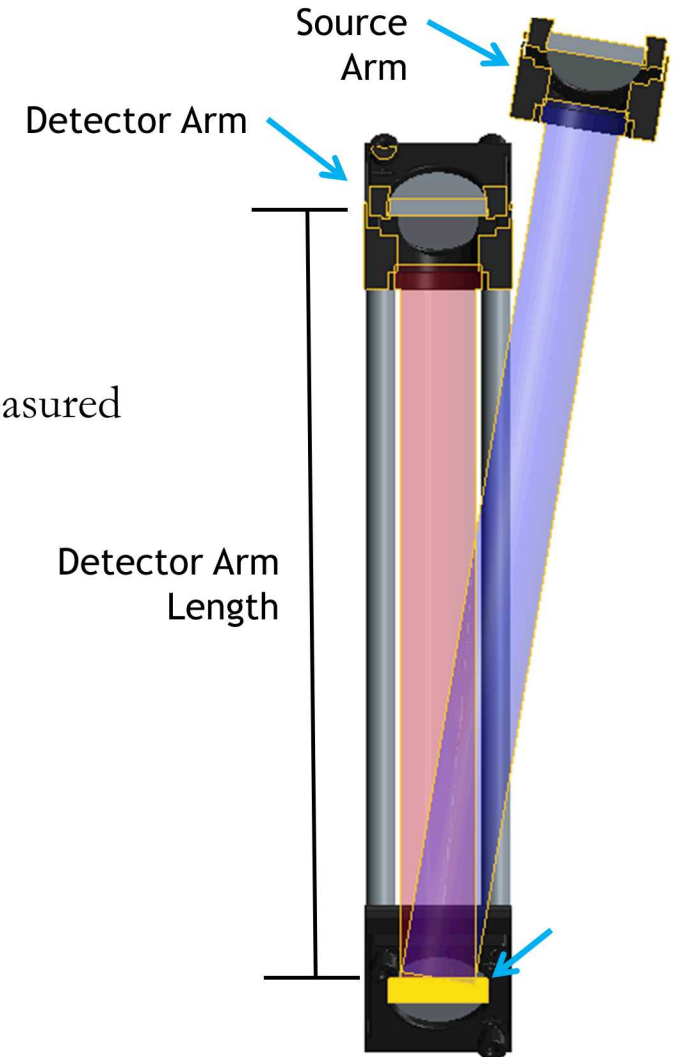

# Instrument Modeling

Radiometric modeling predicts this measurement is hard!

- Broad band source, small solid angles, polarizer loss
- 1% reflective samples -> 10 minutes integration

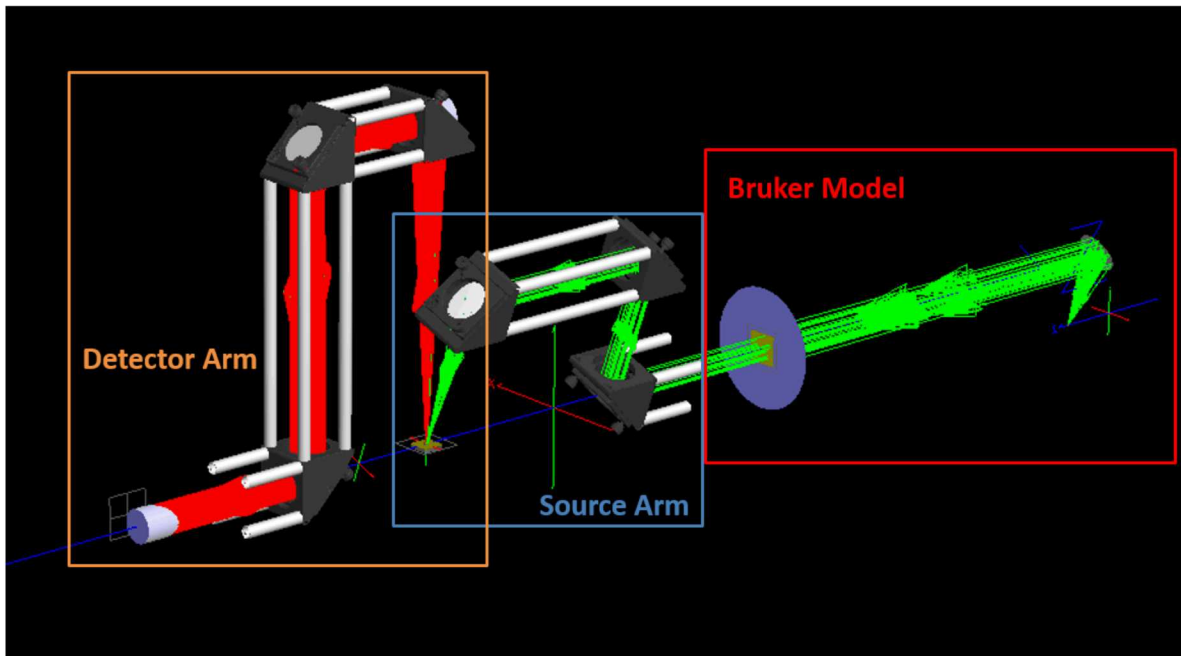

Bruker Model

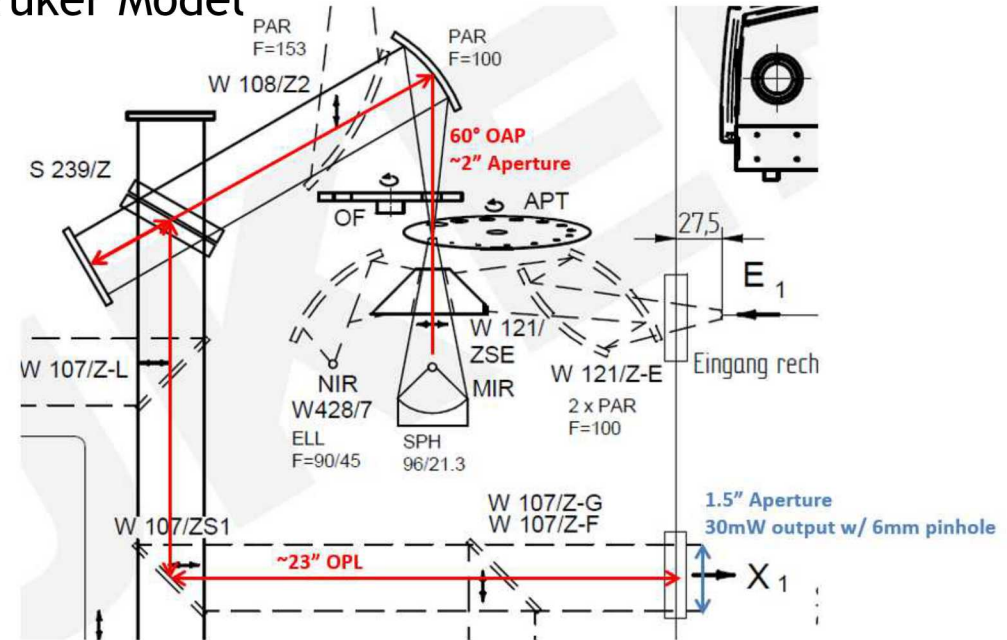

0° AOI

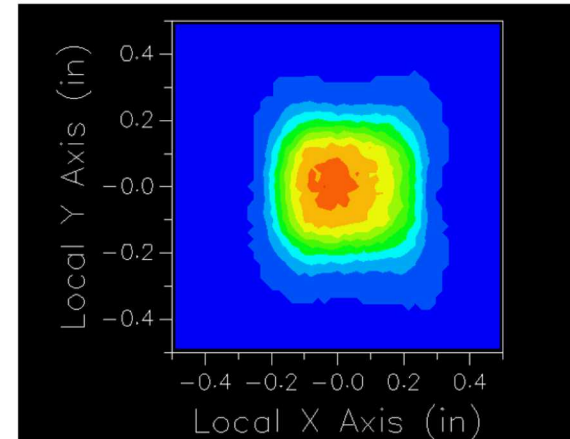

70° AOI

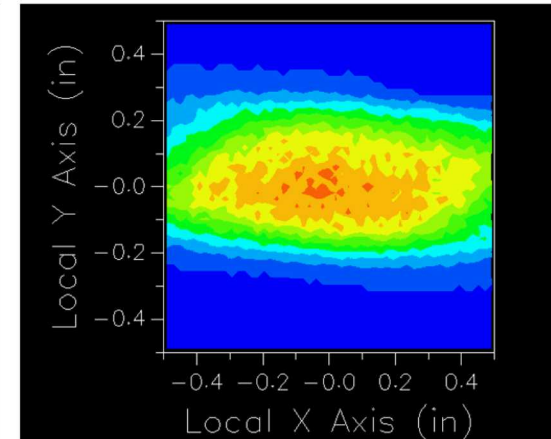

# Instrument

Source Arm Elevation  
Rotation Stage

Detector Arm  
Elevation Rotation  
Stage

Protected Gold  
OPA

Detector

Sample Rotation

Kinematic Alignment  
Mount

Detector Azimuth Rotation

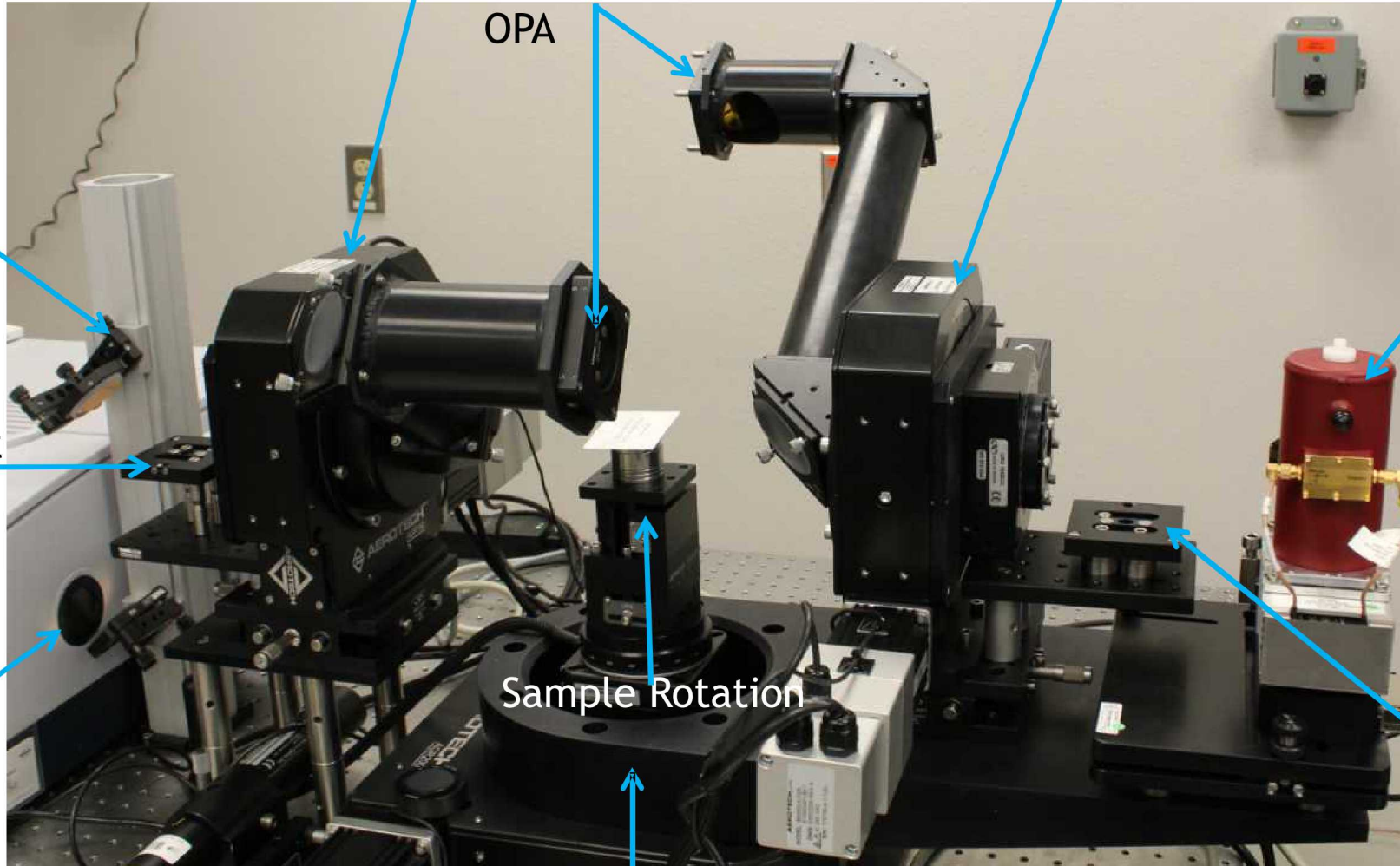

Source Periscope

Kinematic Alignment  
Mount

Source Exit port  
(Bruker Vertex 70)

# Polarimeter in action

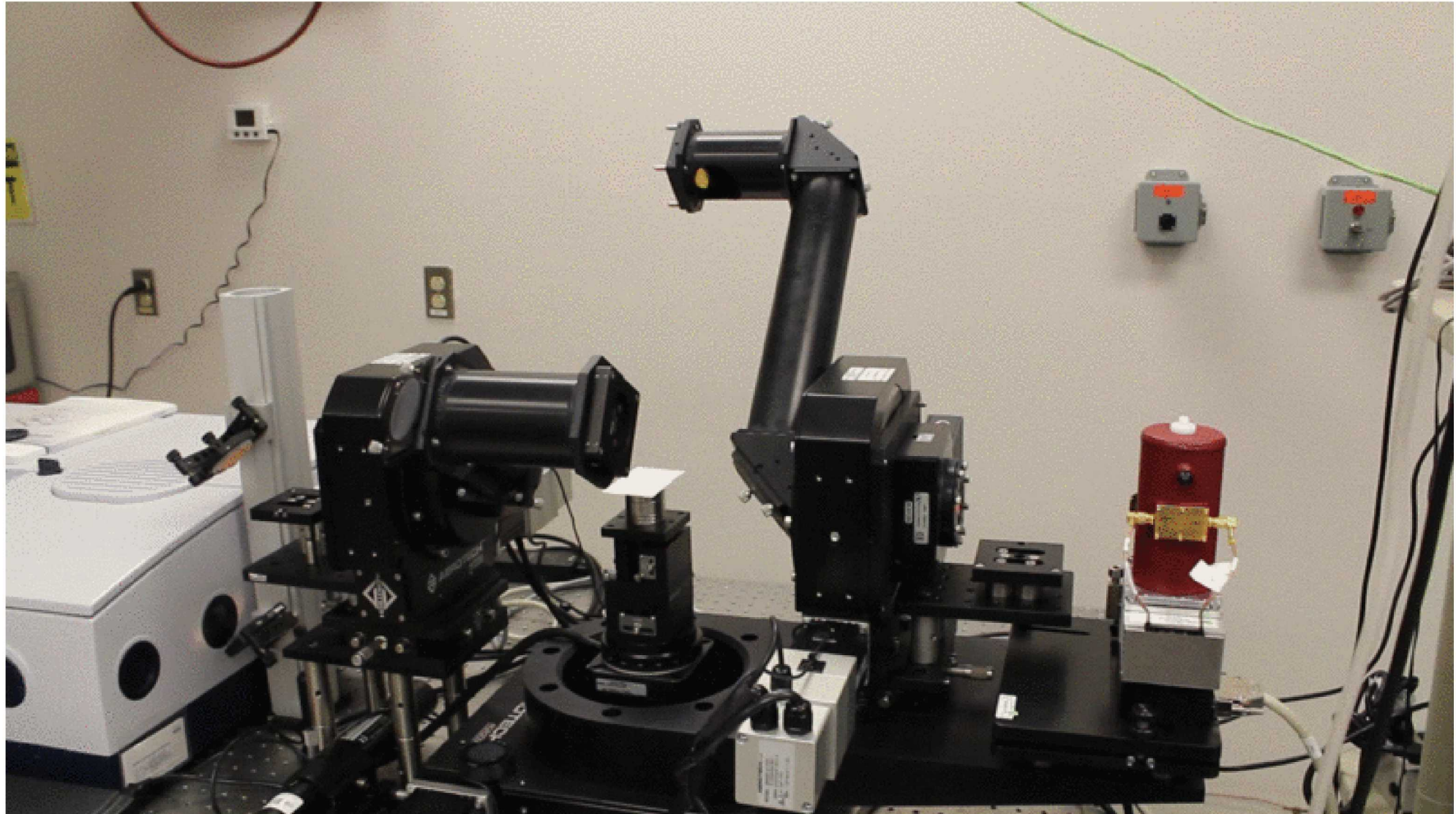

# Reflectance calibration

## Reference method

1. Flux measurements with unknown loss:

$$\rho_{\text{samp}}(\theta_{\text{det}}^{\mathbf{r}}) = \alpha \frac{\Phi_{\text{samp}}(\theta_{\text{det}}^{\mathbf{r}})}{\Phi_{\text{src}}(\theta_{\text{src}}^{\mathbf{r}})}$$

$$\rho_{\text{reference}}(\theta_{\text{det}}^{\mathbf{r}}) = \alpha \frac{\Phi_{\text{reference}}(\theta_{\text{det}}^{\mathbf{r}})}{\Phi_{\text{src}}(\theta_{\text{src}}^{\mathbf{r}})}$$

$\alpha$

- Atmosphere
- Geometrical Loss
- Alignment tolerance

2. Perform reference calibration, not dependent on loss function

$$\rho_{\text{samp}} = \frac{\rho_{\text{reference}} \Phi_{\text{samp}}}{\Phi_{\text{reference}}}$$

3. Reflectance accuracy depends on knowledge of reference sample

## Sample references

### Lab sphere irgold

LASER SOURCE

Spectrally flat at  $94\% \pm 0.5\%$

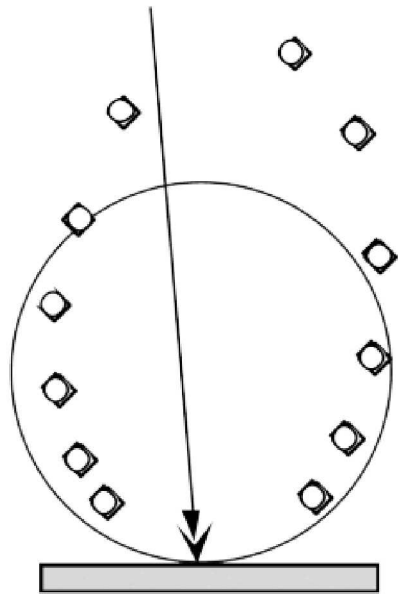

INFRAGOLD

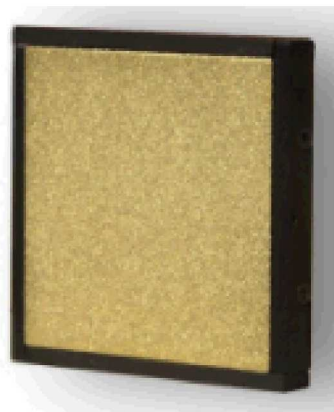

### Thor labs gold coated ground

#### Intensity Distribution at 0° AOI

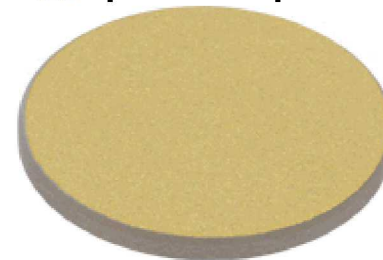
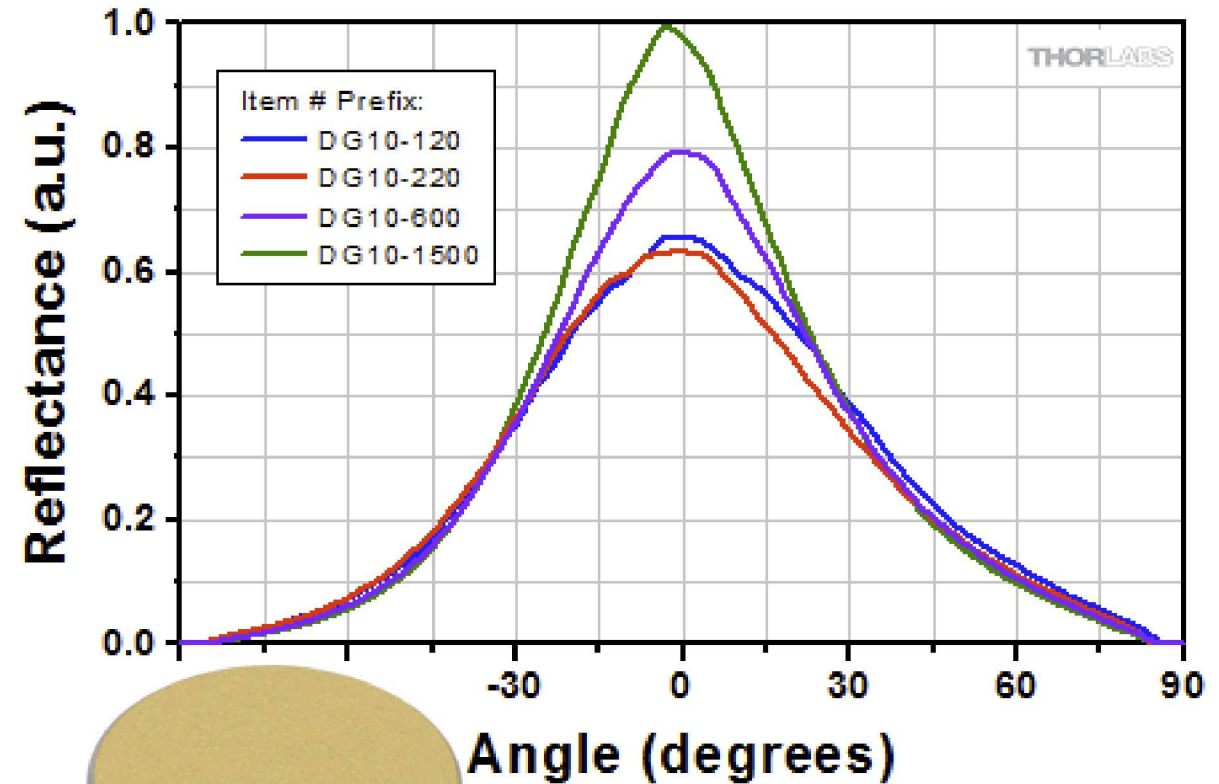

# Polarized reflectance calibration

Need sample with known angularly, spectrally resolved Mueller matrix

- Using known reference captures variability in atmosphere, temperature, etc, in the inversion method

$$\mathbf{W}^{-1} = \mathbf{M}_{\text{ref}} \mathbf{I}_{\text{ref}}^{-1}$$

$$\mathbf{M}_{\text{samp}} = \mathbf{W}^{-1} \mathbf{I}_{\text{samp}}$$

- We currently report only s and p reflection, TBD when we have retarders available
  - It is a challenge to find a calibrated polarization reference...

# Measured Data (120 grit)

Calibrated with Irgold reference

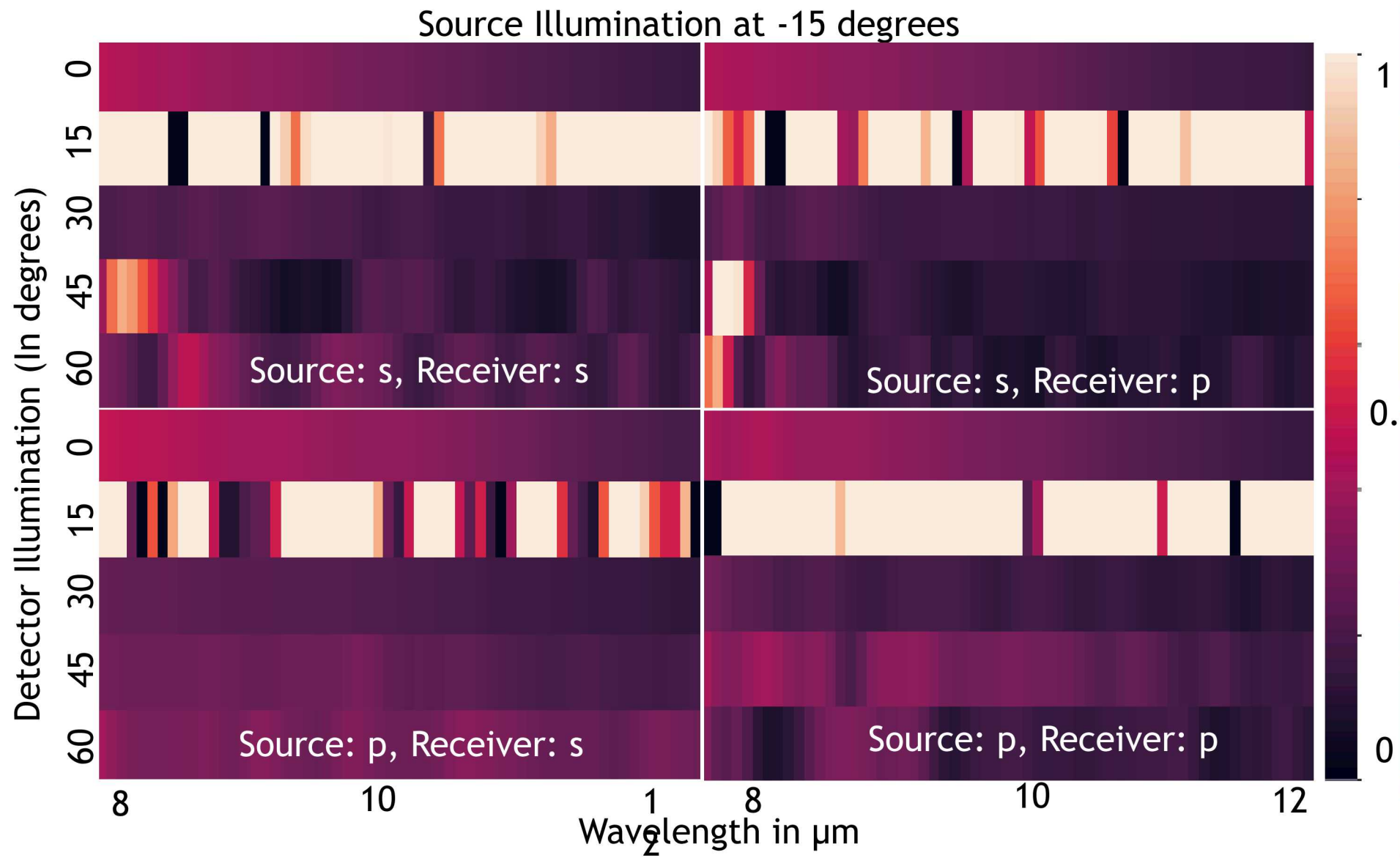

# Measured Data (1500 grit)

Calibrated with Irgold reference

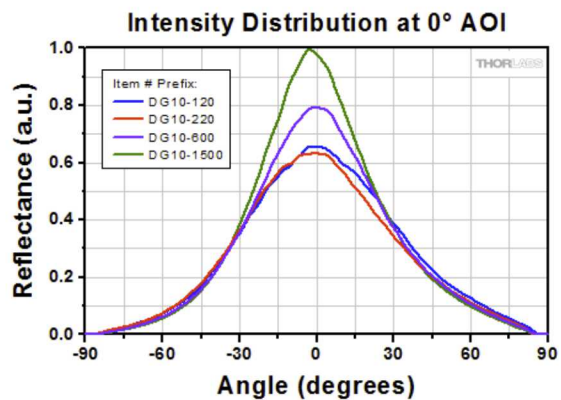

Expected 1500 to be brighter than 120.

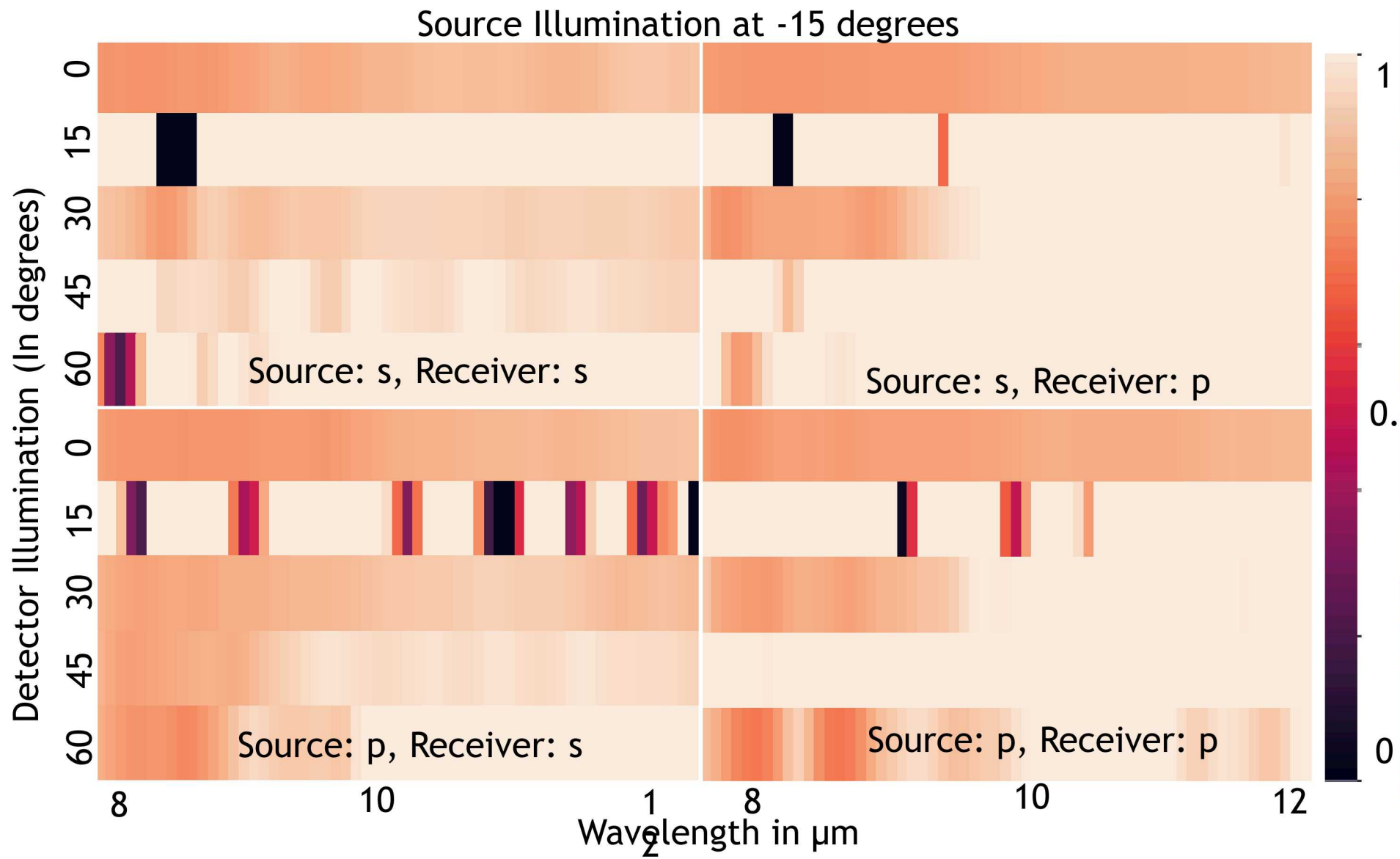

# Measured Data (nhno powder)

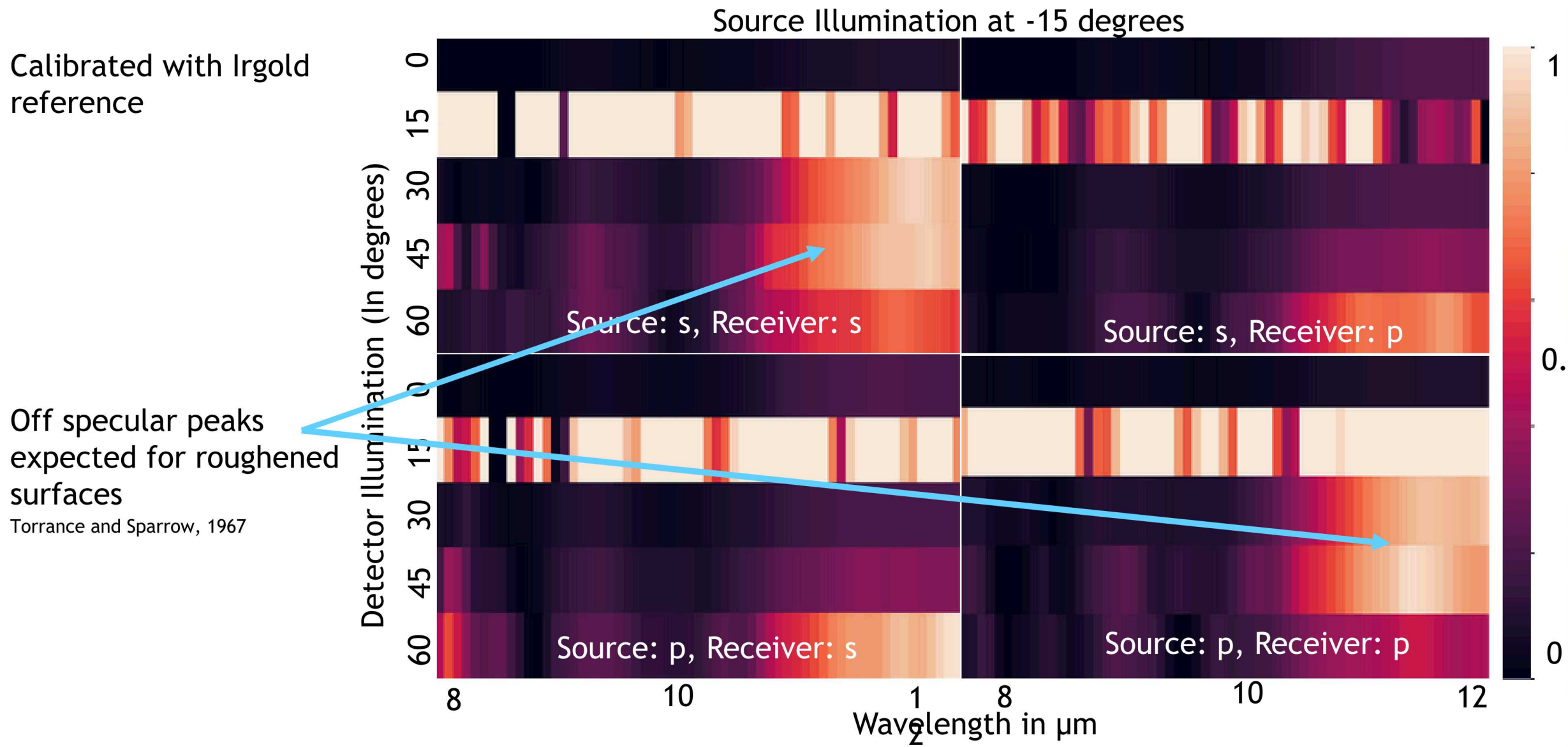

# Validation against SOC 100

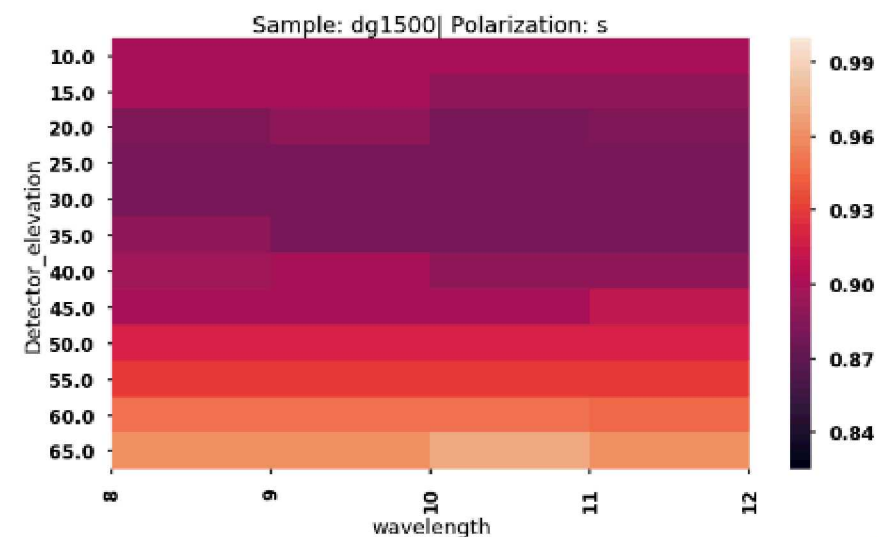
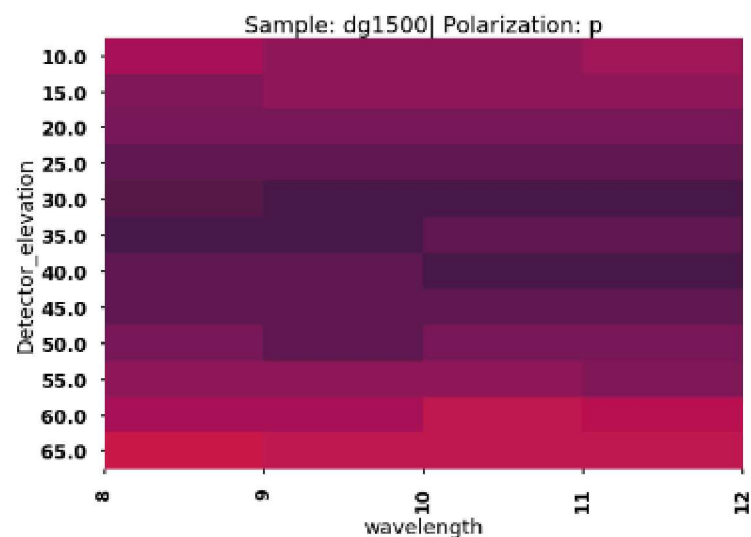
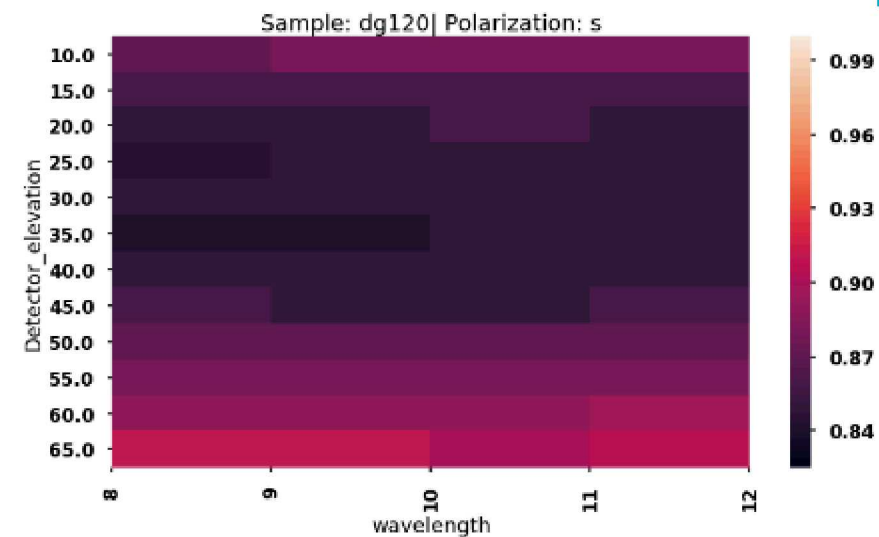
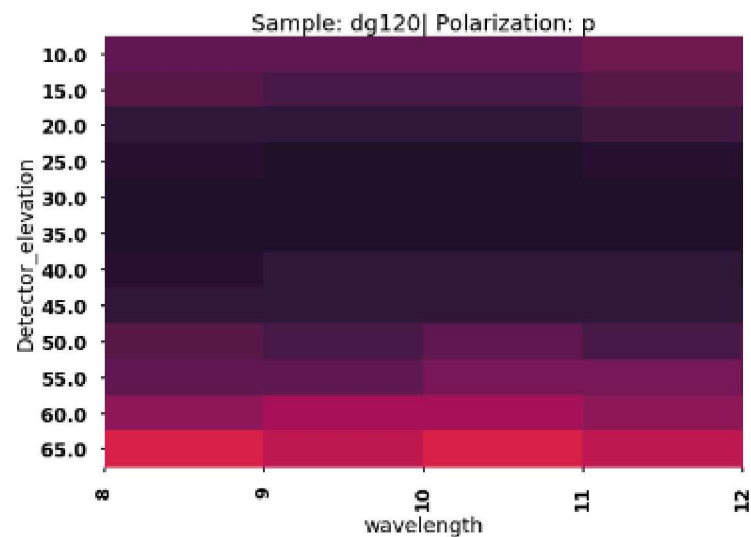

# Summary

## Reference calibration method:

- Compare to flat mirror
  - Can model polarization effects
  - Measurements are only good at specular angles
- Compare to Irgold
  - Good for understanding reflectance of nearly diffuse materials
  - Nonsensical results ( $>1$ ) for samples with large specular component
  - Need to measure polarized reflectance
- Need to move to multi-reference method

