

# Sandia's Hydrogen and Fuel Cells (H<sub>2</sub>FC) Program

*Enabling Hydrogen Technologies with  
Science and Engineering*

Jonathan Zimmerman

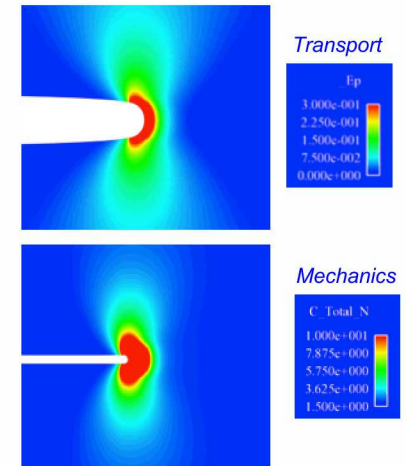
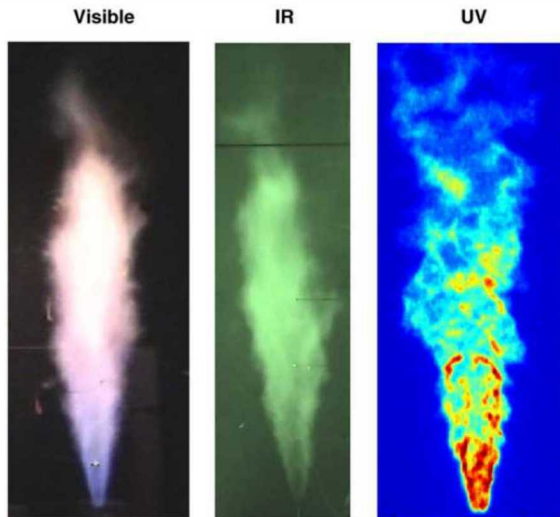

# History of Hydrogen Sciences at Sandia

*Sandia's core mission to support the nuclear deterrent has enabled science and engineering for energy programs*

## EXPERIMENTAL HYDROGEN PIPELINE FACILITY

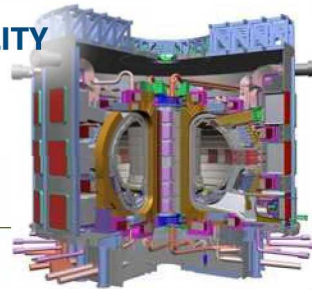
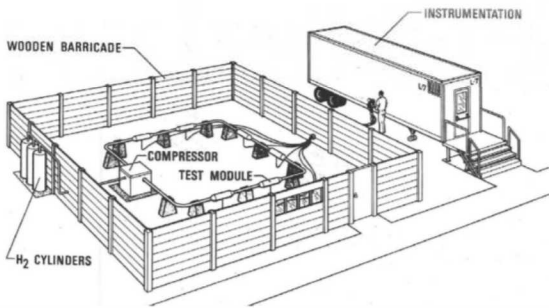

**FUSION ENERGY SCIENCES**

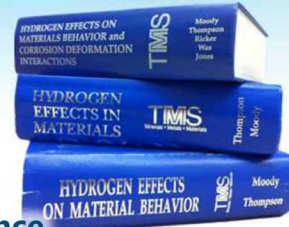

**Conference Organization**

**Lift-Truck Lifecycle**



**H<sub>2</sub> Infrastructure**



1960      1970      1980      1990      2000      2004      2008      2012      2016



**METALLURGY**

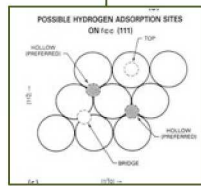

**Embedded Atom Method**



**RATLER**



**AUTOMOTIVE STORAGE**

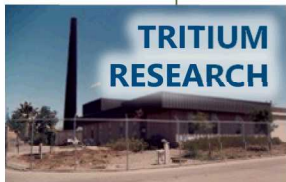

**TRITIUM RESEARCH**

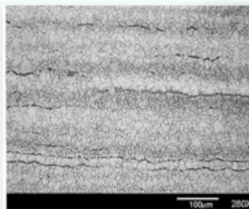

**MINING LOCOMOTIVE**

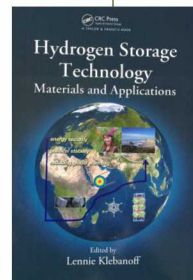
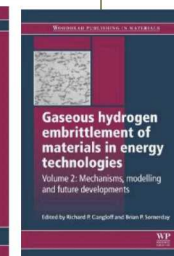
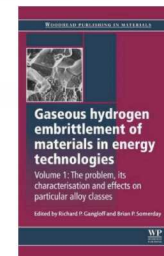

# Sandia's Current Hydrogen Program

## Hydrogen Production

Develop technologies that utilize concentrated solar power for large-scale, renewable production of hydrogen



## Hydrogen Delivery

Identify pathways for reducing cost of steel hydrogen pipelines without compromising reliability and integrity

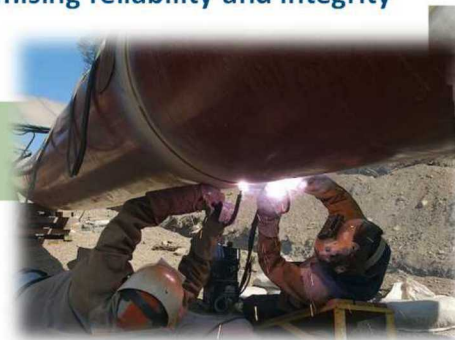

## Hydrogen Storage

Provide fundamental understanding of the phenomena limiting solid-state hydrogen interactions

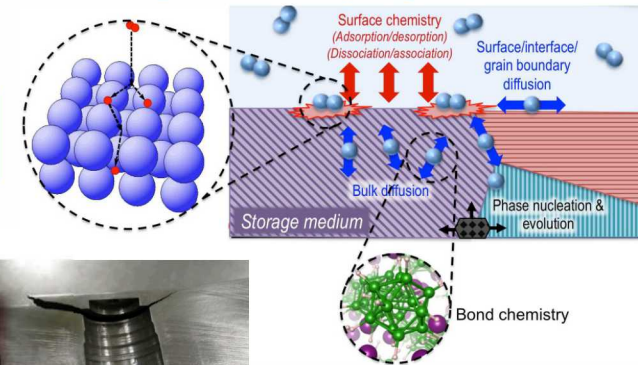

## Safety, Codes and Standards

Facilitate safe deployment of hydrogen technologies with science-based codes and standards

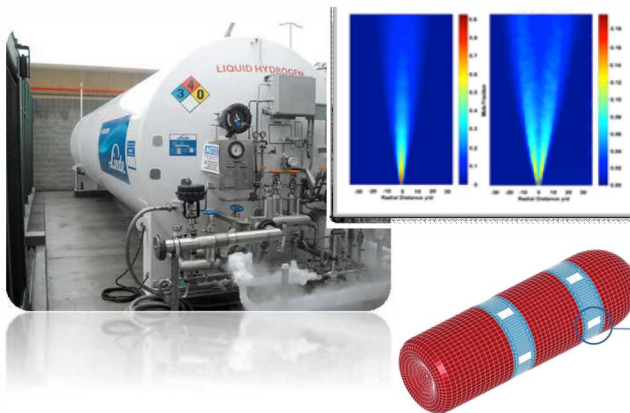

## Fuel Cells

Develop new membrane systems for enhanced electrochemical performance



## Systems Engineering

Demonstrate innovative engineering solutions to harness clean energy technologies



# Capabilities for Hydrogen Research and Development

## Risk Assessment

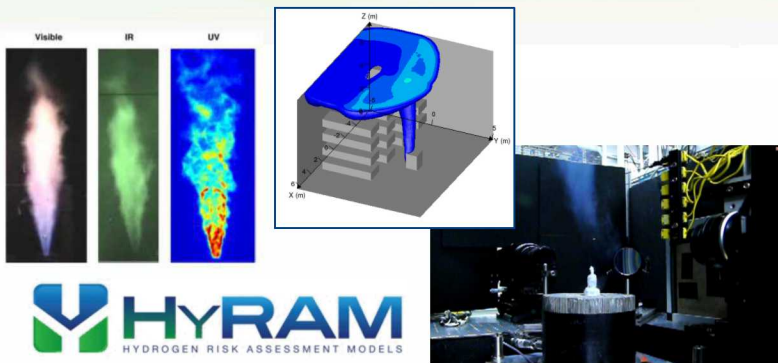

## Solar Thermochemical Hydrogen Production

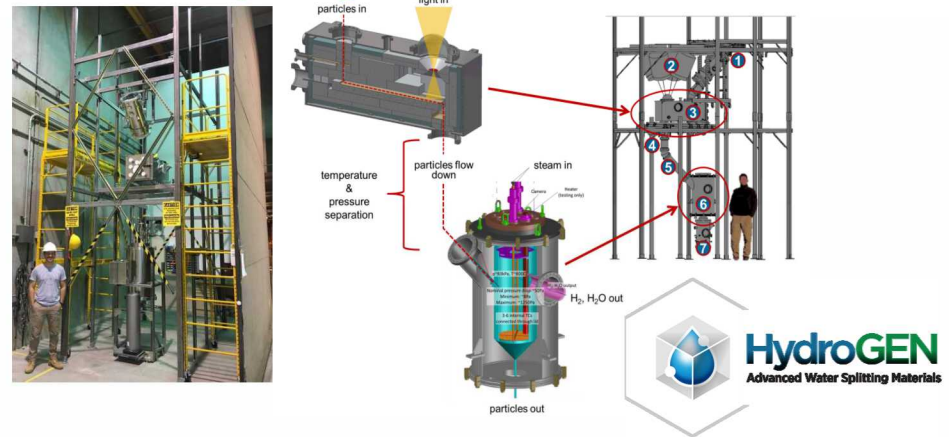

## Infrastructure Research and Station Technology



## Materials Compatibility with Hydrogen



# Capabilities for Hydrogen Research and Development

## Hydrogen Storage Materials

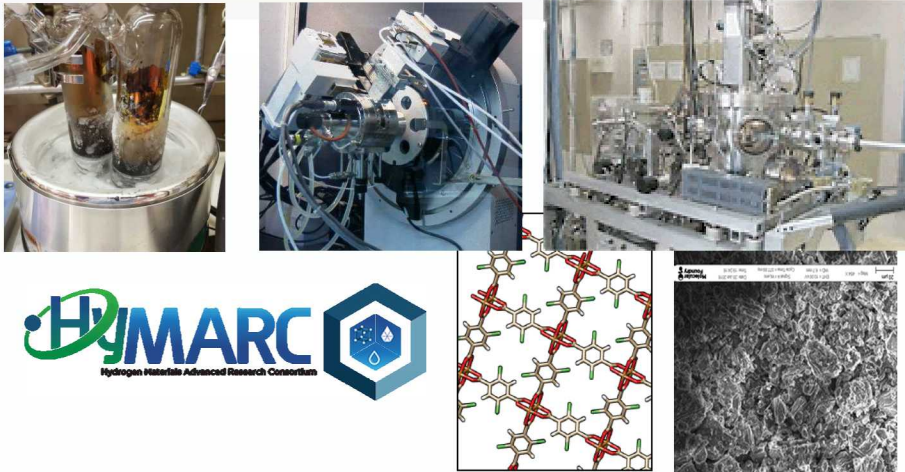

## Fuel Cell Membranes

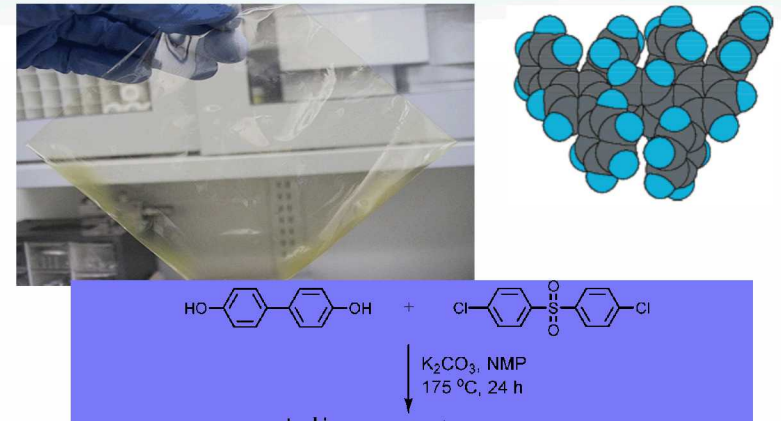

## Systems Engineering

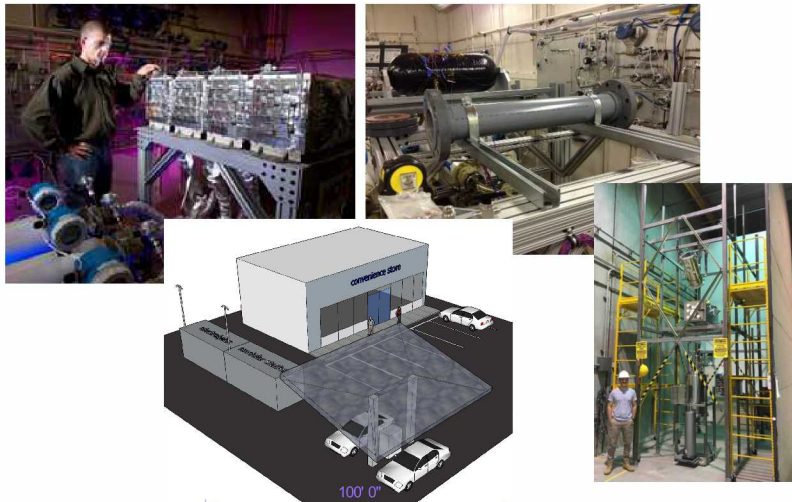

## Infrastructure Scenario and Techno-economic Analysis

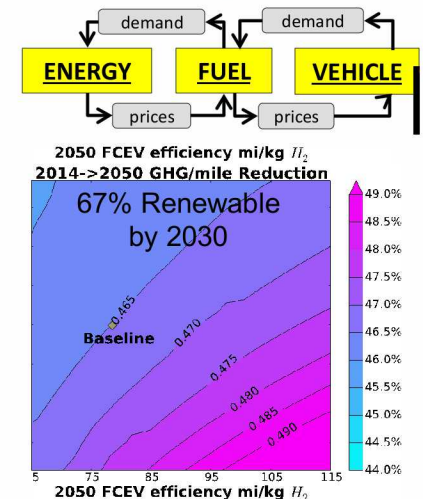
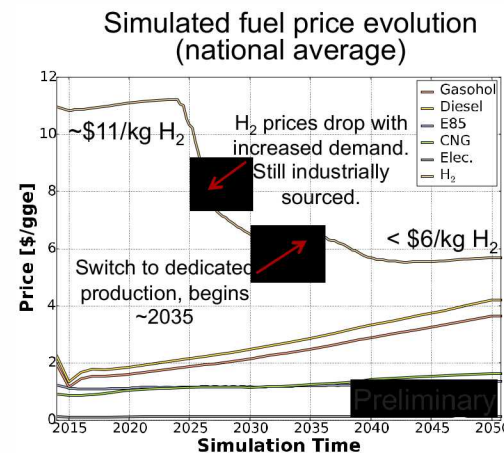

# Capabilities for Hydrogen Research and Development

## Thermal/Fluids Modeling and Simulation

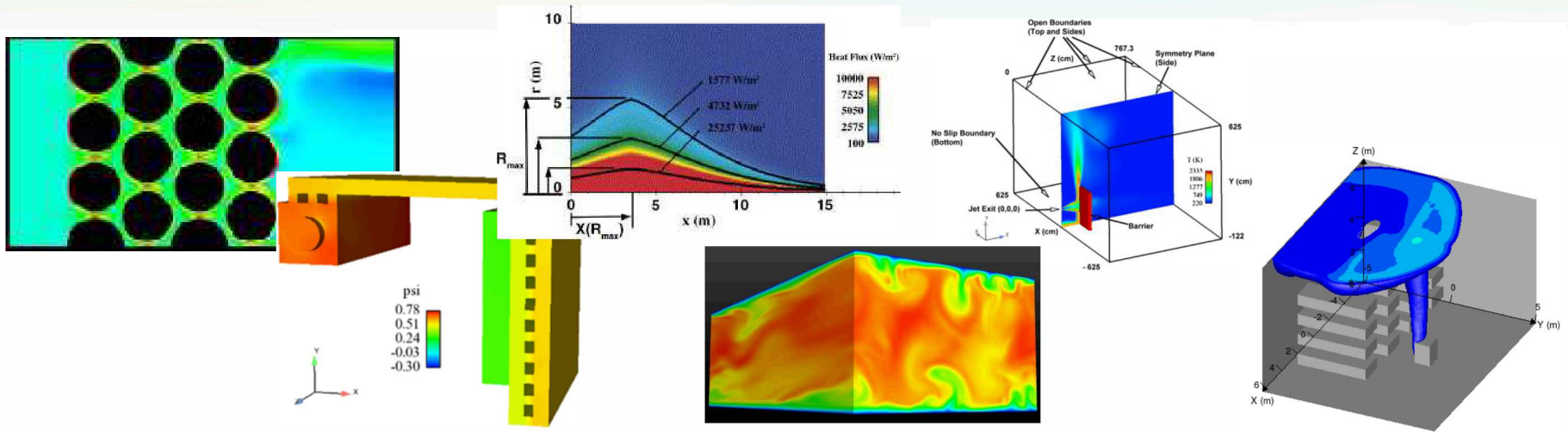

## Infrastructure for High-Performance Computing

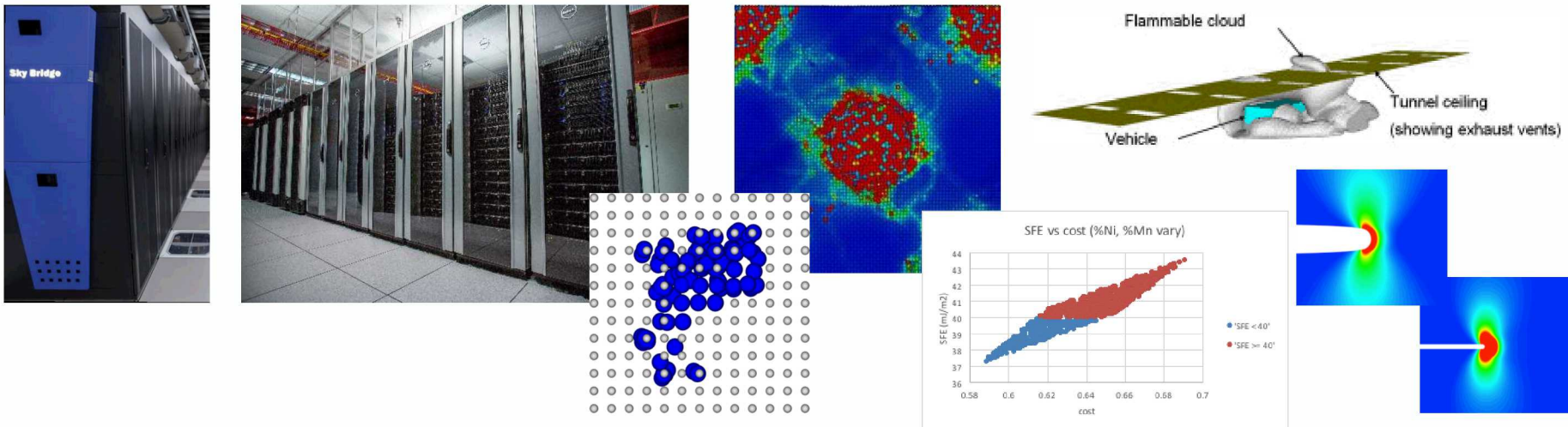

# Capabilities for Hydrogen Research and Development

*Permeation and Thermal Desorption Instruments and Expertise*

*Electron Microscopy-Based Expertise in Interface Science and Material Defects*

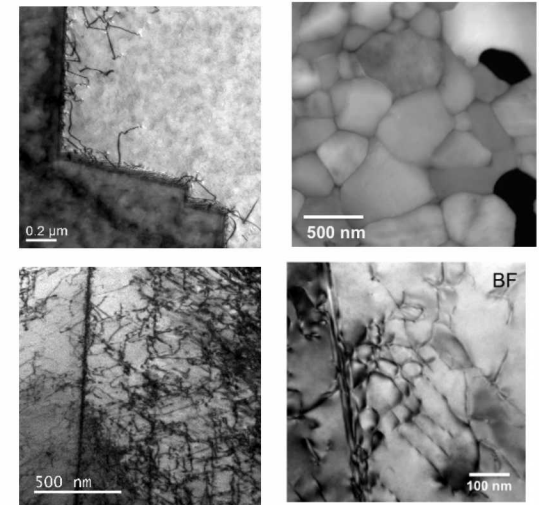
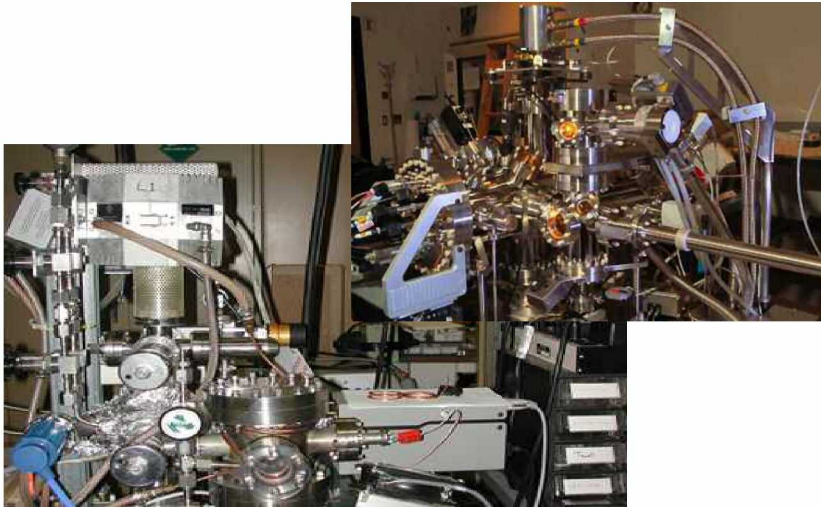

## *Angle-Resolved Ion Energy Spectrometry (ARIES)*

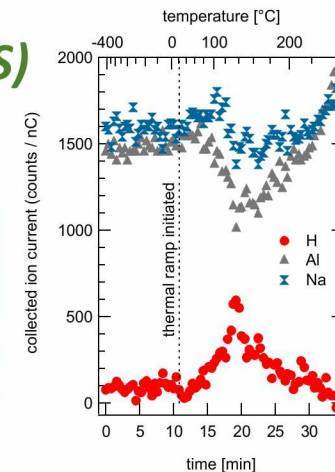
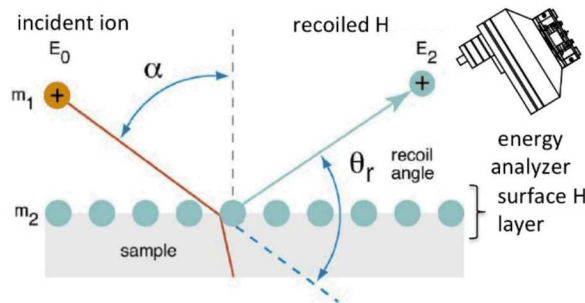

# Hydrogen Science is Key to Developing Predictive Engineering Tools for Safety, Codes and Standards

Radiative properties of H<sub>2</sub> flames quantified

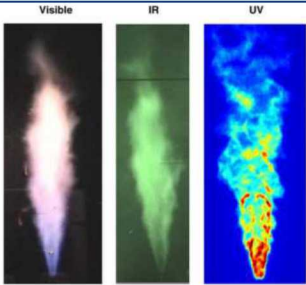

Barrier walls for risk reduction

Ignition of under-expanded H<sub>2</sub> jets

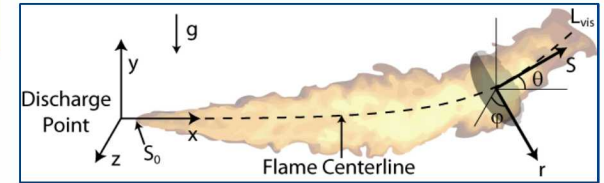
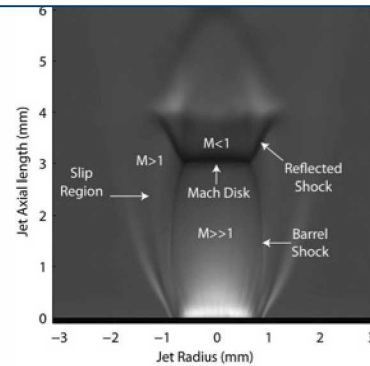

Buoyant jet flame model with multi-source radiation

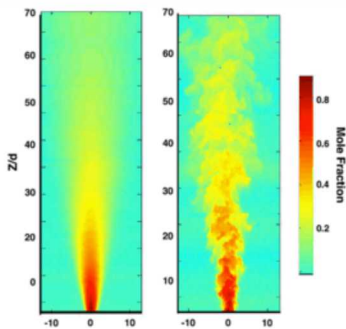

Advanced laser diagnostics applied to turbulent H<sub>2</sub> combustion

Ignition limits of turbulent H<sub>2</sub> flows

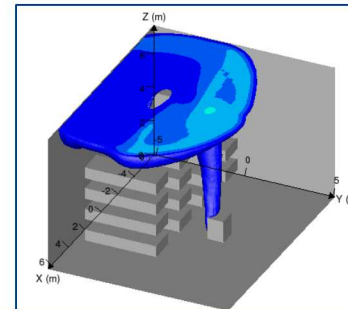
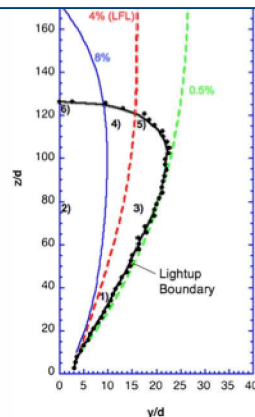

Experiment and simulation of indoor H<sub>2</sub> releases

Laboratory-scale characterization of LH<sub>2</sub> plumes and jets

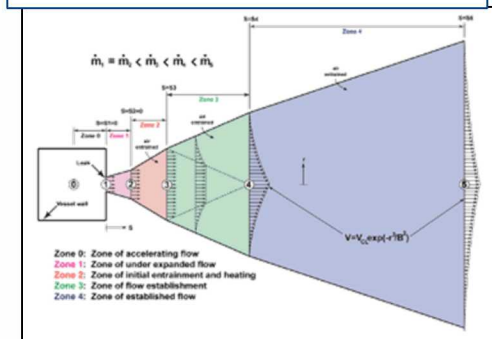

# Making Science Accessible through Integrated Tools

**risk**

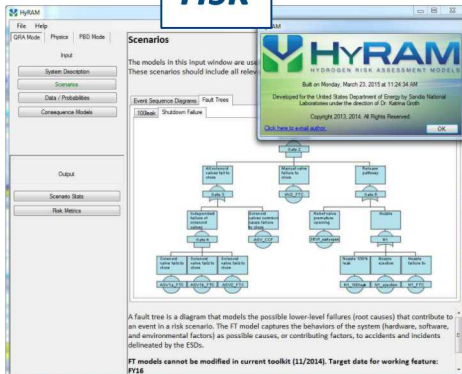

**Develop integrated methods and algorithms**

for enabling consistent, logical and defensible QRA

**application**



**Apply quantitative risk assessment techniques**

in real hydrogen infrastructure and emerging technology

**behavior**

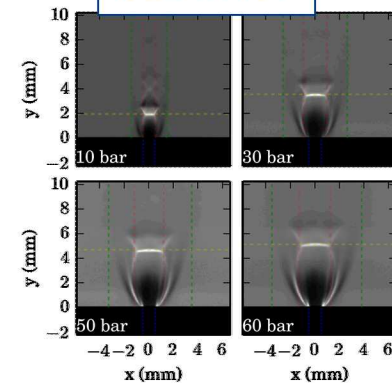

**Develop and validate scientific models**

to accurately predict hazards and harm from liquid releases, flames, etc.

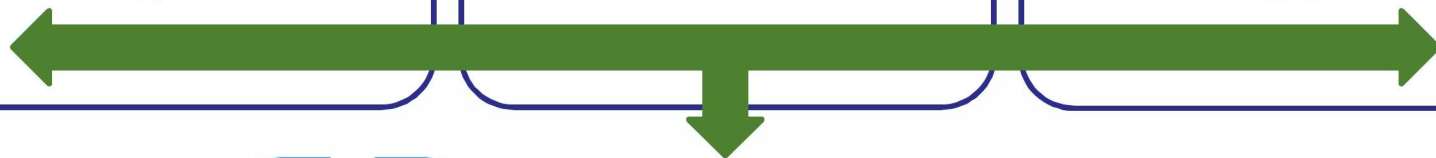

**HYRAM**  
HYDROGEN RISK ASSESSMENT MODELS

[hynam.sandia.gov](http://hynam.sandia.gov)

# International Leadership in Materials Compatibility Enables Innovation of Hydrogen Technologies

Develop test methods

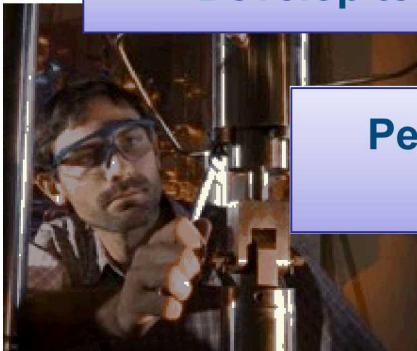

Performance-based testing (compatibility)

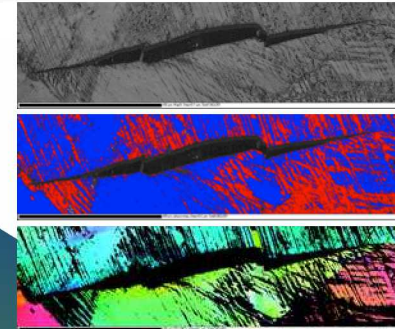
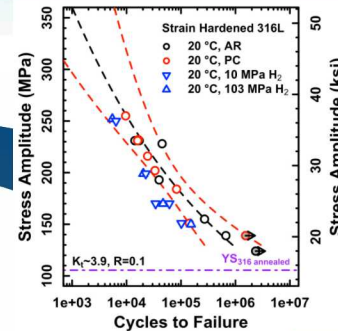

Understanding physics of hydrogen embrittlement

Predictive models

System validation (suitability)

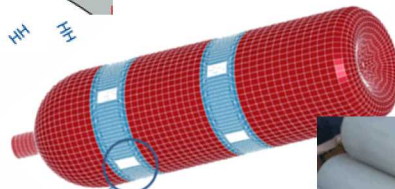
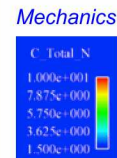
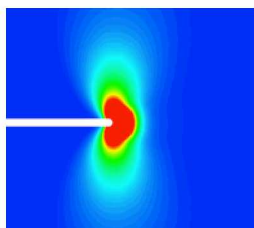
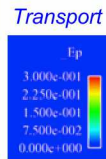
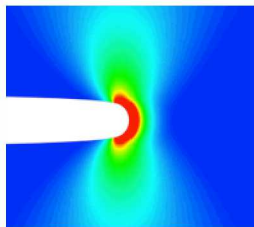
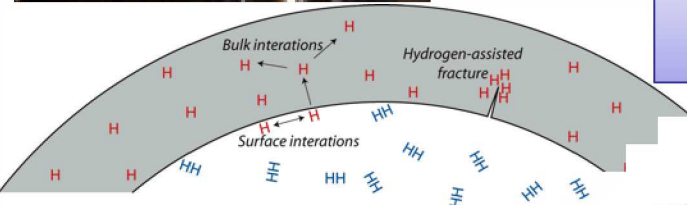

# Evaluating Materials Options and their Hydrogen Compatibility Using Experiments and Modeling

Mechanical testing and characterization to guide commercial alloy selection

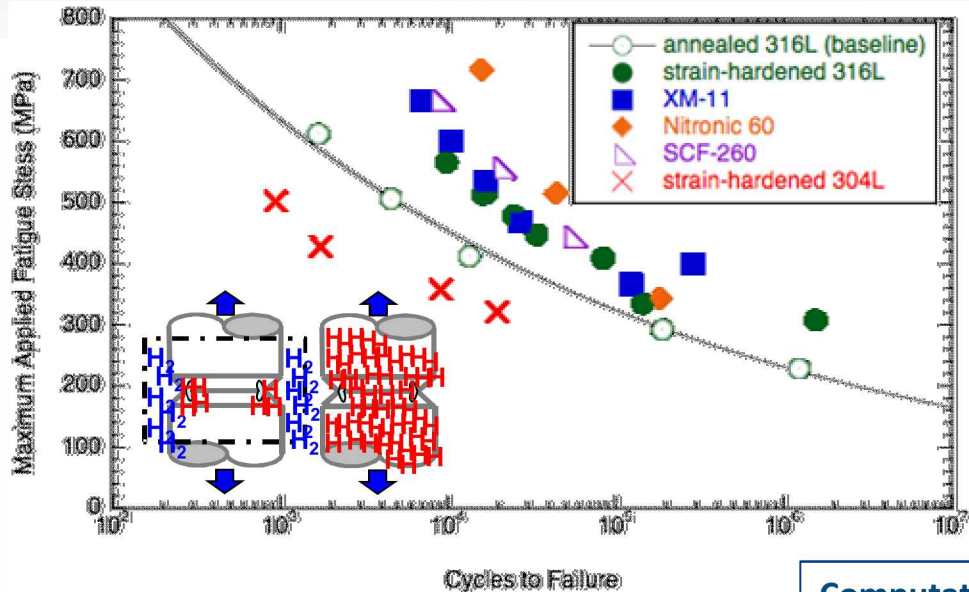
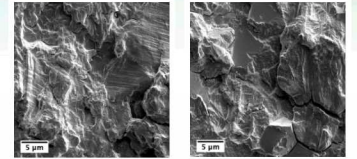

Material	Raw Material Cost	Yield Strength (MPa)	Weight Savings (%)	Relative Material Cost (%)
316L (A)	1.0	170	0	100
316L (CW)	1.2	570	70	36
21Cr-6Ni-9Mn (XM-11)	0.8	540	69	33
304L (CW)	1.0	540	68	26
Nitronic 60	1.0	415	59	48
SCF 260	1.1	965	82	23

Computational approaches to explore alloy compositions through prediction of intrinsic material properties

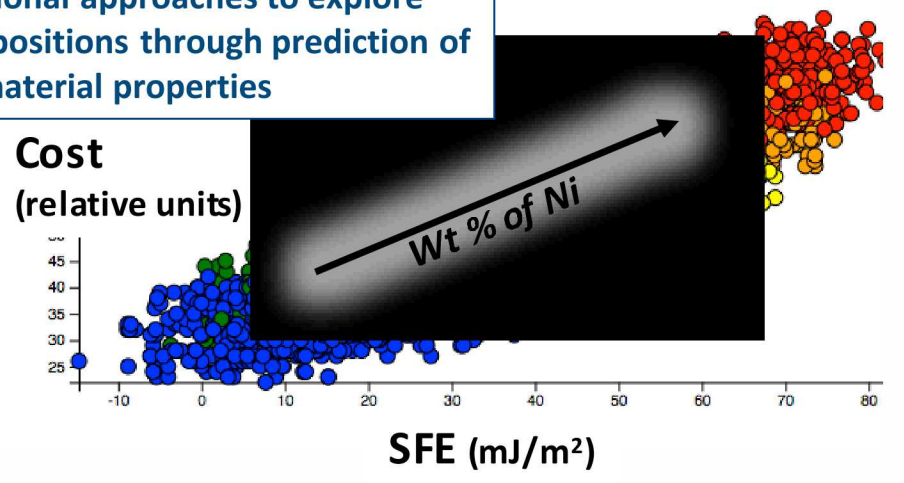
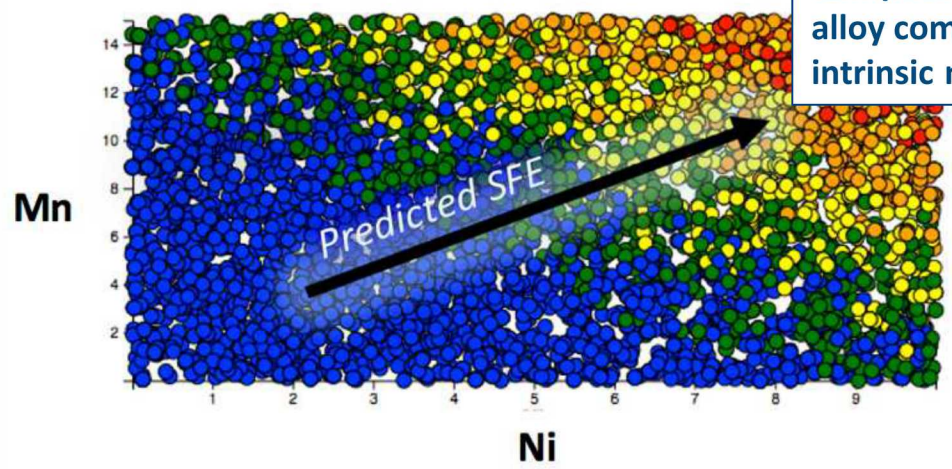

# Hydrogen Fueling Infrastructure Research and Station Technology (H<sub>2</sub>FIRST)

Goal: Leverage capabilities and expertise of national laboratories to address challenges for hydrogen fueling station deployment.

Key areas focused on include:

- Station Design, Status and Requirements
- System Cost and Reliability Engineering
- Station Acceptance and Qualification
- Fuel Containment Detection



**Hydrogen Station Equipment Performance (HyStEP) –**  
*Accelerate commercial hydrogen station acceptance by developing and validating a prototype device to measure hydrogen dispenser performance.*

Today's Problem: Each OEM performs vehicle test fills to validate station



HyStEP acts as FCEV surrogate; operated by testing agency



**Fill safely**

**Follow standards:**

SAE J2601-2014 (fueling protocol)

CSA HGV 4.3 (dispenser test method)

**Test stations**

# Large-Scale Renewable Hydrogen Production using Solar Power Leads to a Sustainable Energy Future

MW scale concentrating solar power provides heat for

1. Metal oxide reduction
2. Oxidation with water *producing H<sub>2</sub>*

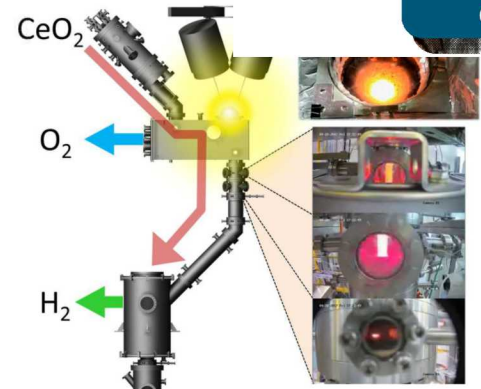
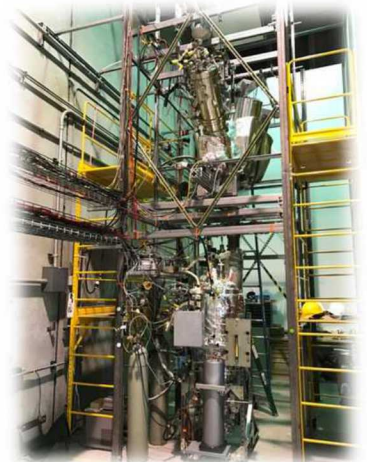
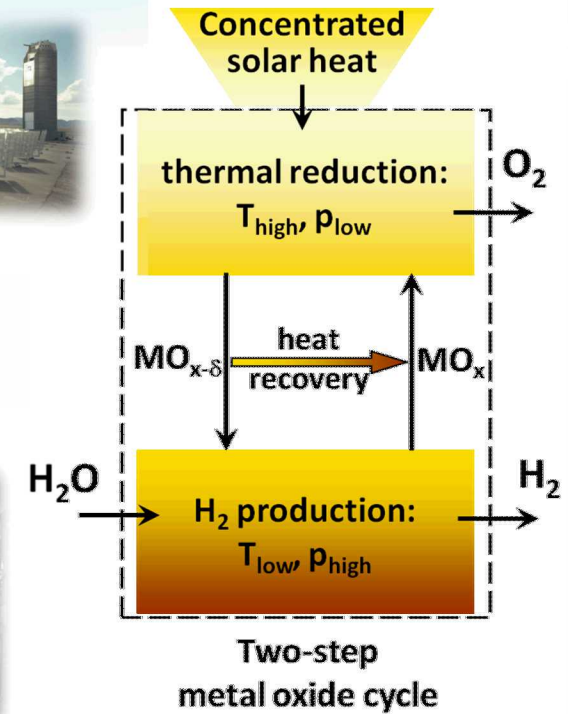
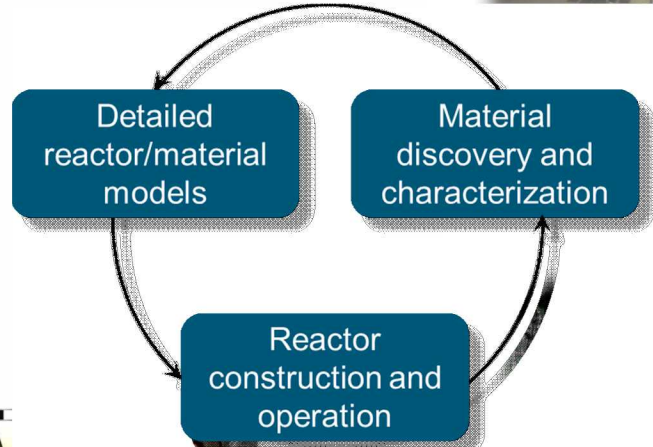
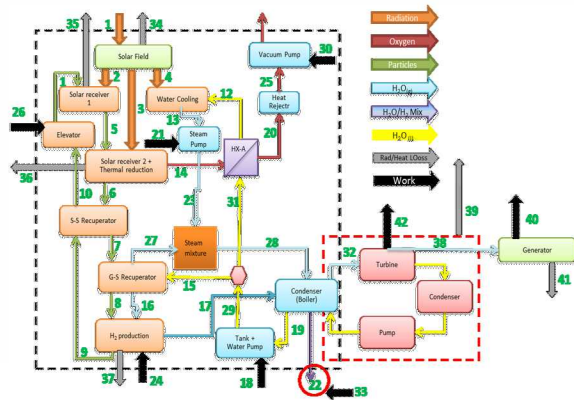

CPR<sup>2</sup> technology produced 2 liters of hydrogen on simulated sun.

*The challenge is to develop efficient and scalable solar-powered reactors up to 100,000 kg/day*



# HydroGEN-Advanced Water-Splitting Materials Consortium

<https://www.h2awsm.org/>



Comprising more than 80 unique, world-class capabilities/expertise in:

## Materials Theory/Computation

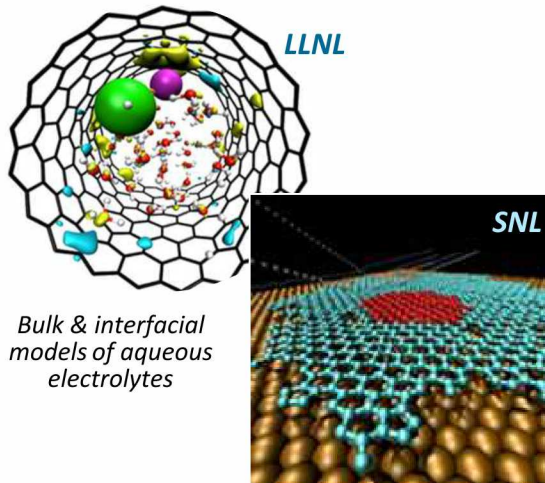

Bulk & interfacial models of aqueous electrolytes

LAMMPS classic molecular dynamics modeling relevant to H<sub>2</sub>O splitting

## Advanced Materials Synthesis

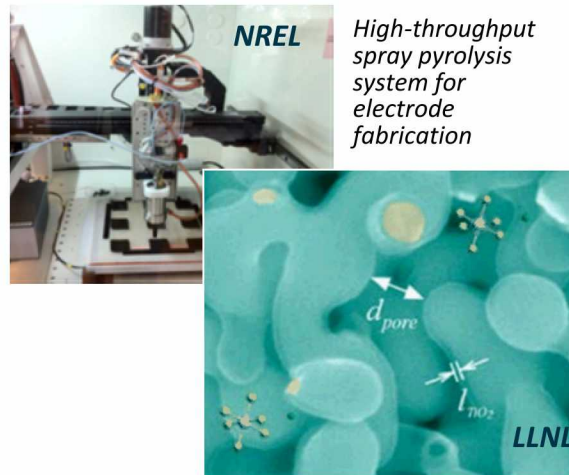

High-throughput spray pyrolysis system for electrode fabrication

Conformal ultrathin TiO<sub>2</sub> ALD coating on bulk nanoporous gold

## Characterization & Analytics

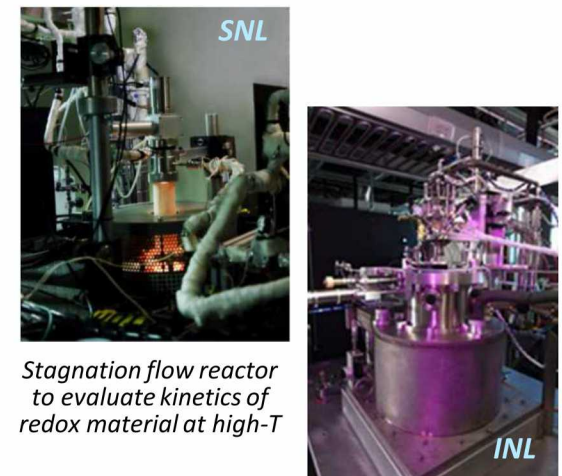

Stagnation flow reactor to evaluate kinetics of redox material at high-T

TAP reactor for extracting quantitative kinetic data

**HydroGEN fosters cross-cutting innovation using theory-guided applied materials R&D to advance all emerging water-splitting pathways for hydrogen production**



# Hydrogen Storage – Advancing solutions for materials

<https://hymarc.org>



**Hydrogen Materials Advanced Research Consortium (HyMARC)** – Develop fundamental understanding of the underlying phenomena limiting solid-state hydrogen storage materials, thereby enabling breakthroughs to new materials meeting all DOE targets.

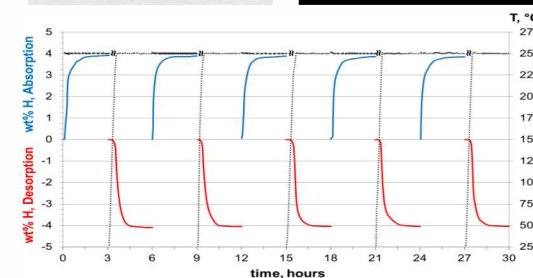
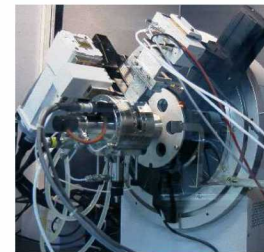
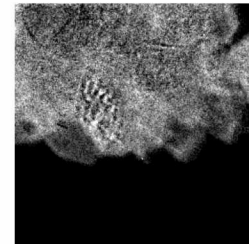
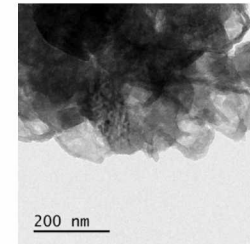
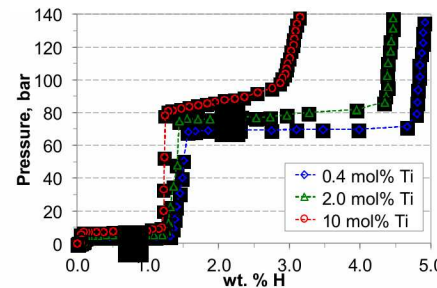
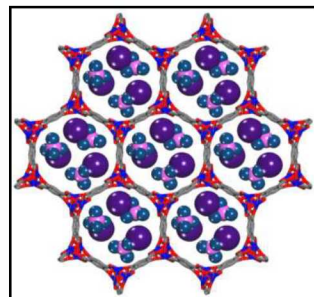
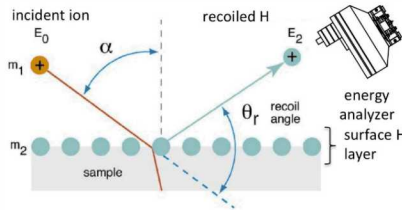
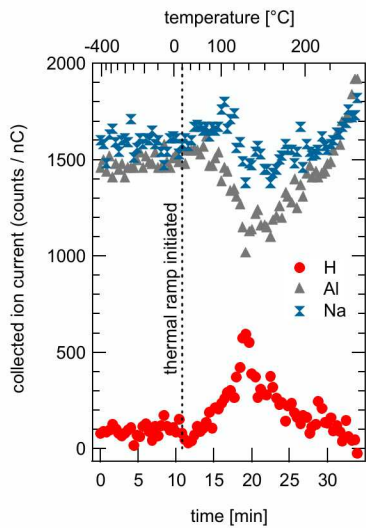
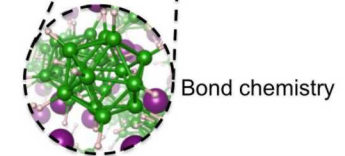
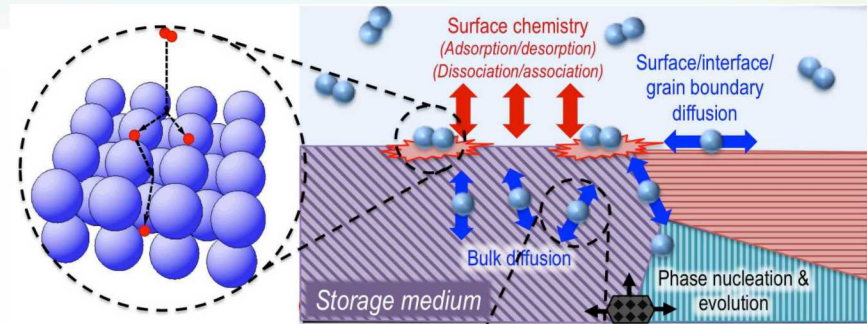

# Early-Market Demonstrations of Hydrogen Tech

## Hydrogen Fuel Cell Mobile Light Tower

- Zero emissions
- Quiet alternative to mobile diesel power



## Hydrogen Fuel Cell Generator for Maritime/Ports

- Quiet, deployable power
- Containerized, clean power

**YOUNG BROTHERS**



## Zero Emission Maritime Vessels

- Green transportation over water
- SF-BREEZE Passenger Ferry
- Zero-V Coastal Research Vessel



# SF-BREEZE high-speed hydrogen fuel cell ferry

## Ferry concept

- Quiet, zero-emissions
- ~150 passenger, >25 kts
- 1,000 kg/day hydrogen demand

## Enables deployment of large-scale hydrogen station

- > 1,200 kg/day capacity
- Cost-effective fuel for vessels, cars, buses, and trucks

## Feasibility study

## funded by

## DOT/MARAD

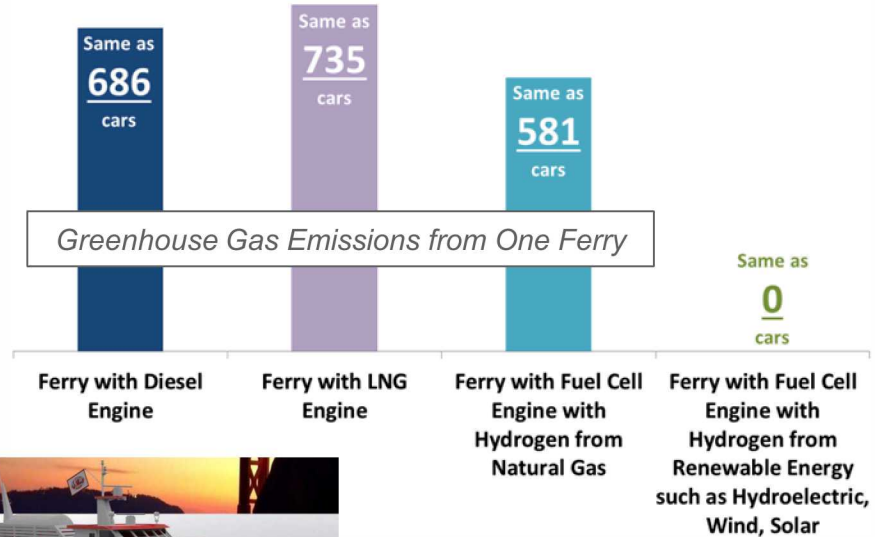

**SANDIA REPORT**  
SAND2016-9719  
Unlimited Release  
Printed September 2016

**Feasibility of the SF-BREEZE:  
a Zero-Emission, Hydrogen Fuel Cell,  
High-Speed Passenger Ferry**

Joseph W. Pratt and Leonard E. Kiebanoff

Passenger ferry

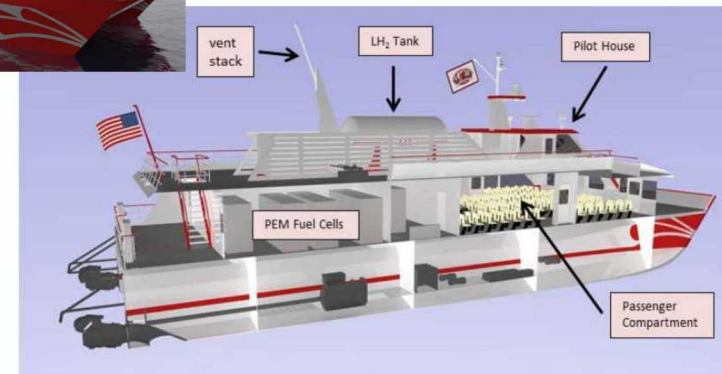

These vessels “have the potential to provide the Bay Area and the country with an entirely new green industry.”  
– letter from Monique Moyer, Director, San Francisco Port

# Zero-V hydrogen fuel cell coastal research vessel

Design and Feasibility study funded by DOT/MARAD

- SNL partnership with Scripps Institution of Oceanography, Glosten and the class society DNV GL.
- Feasibility was found for a
  - 10-knot vessel
  - 2400 nautical mile range,
  - Able to perform 14 Scripps science missions
  - Refueled with ~11,000 kg of liquid hydrogen at 4 different ports of call along the U.S. west coast.
- Zero emissions on the vessel itself
- Successful project has implications for large hydrogen fueled vessels such as cargo vessels and cruise ships.



Table VI: Zero-V Overall Design Specifications

Hull Type	Trimaran
Material	Aluminum
Length	170 ft.
Beam	56 ft.
Draft	12 ft.
Freeboard	9 ft.
Displacement	1,175 LT
Cruise Speed	10 knots
Range	2,400 nm
Endurance	15 days
Station Keeping	Dynamic positioning
Berths	18 Staterooms (8 double, 2 single) 11 Crew (single)
Air Emissions	Water vapor

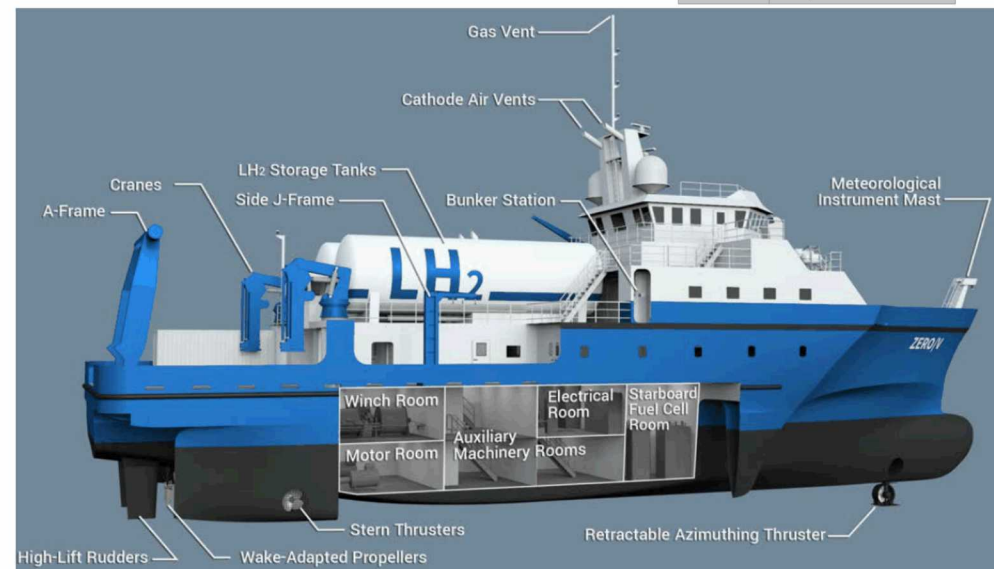
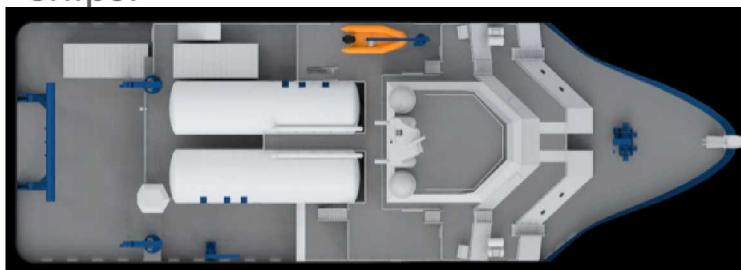

# Customers and Partners



# H2@Scale: Conceptual Low-Carbon Energy System\*

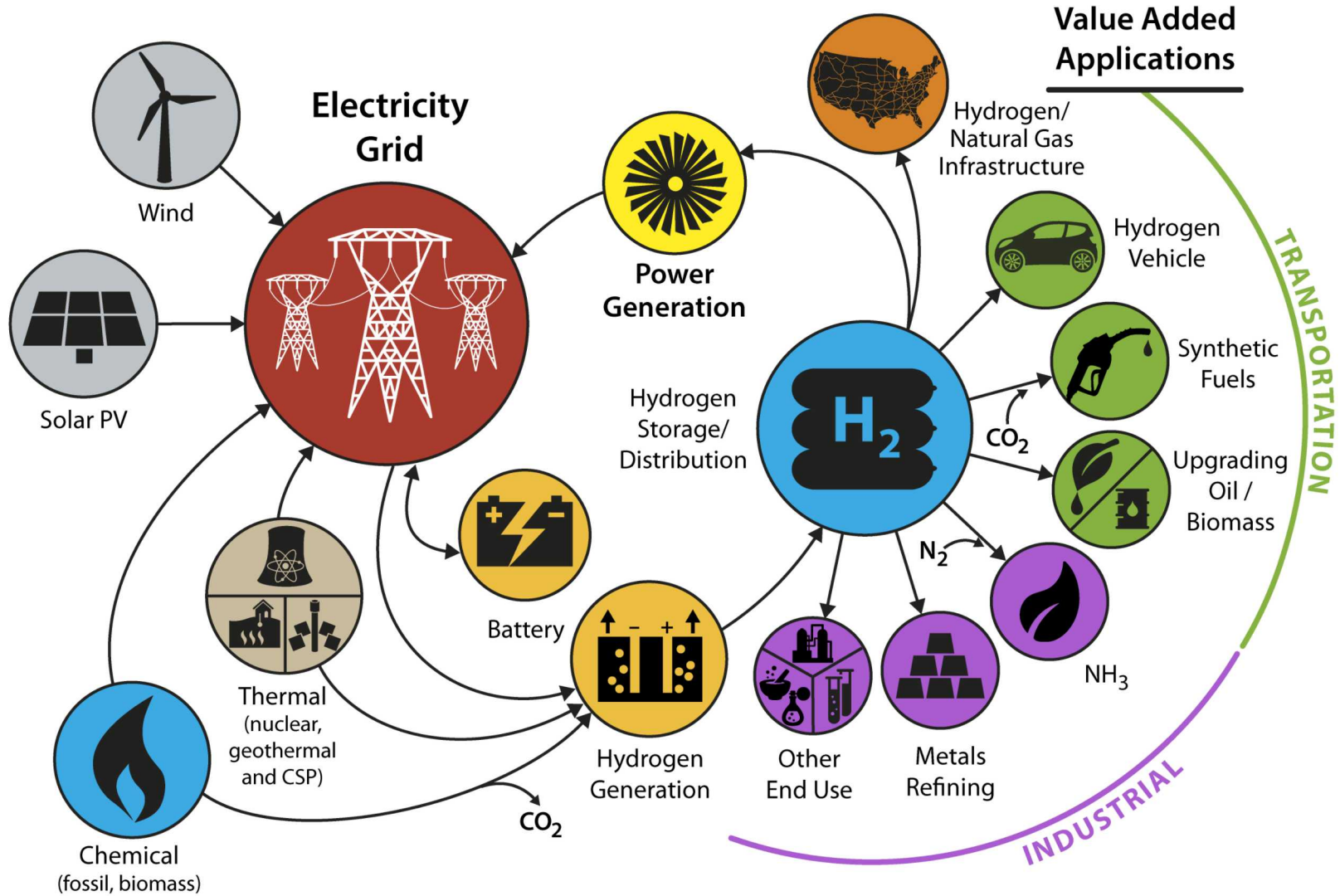

\*Illustrative example, not comprehensive; from H2@Scale Big Idea Concept, Pivovar et al