



U.S. DEPARTMENT OF
ENERGY

SAND2018-5467PE
Nuclear Energy

Spent Fuel and Waste Science and Technology: Disposal Research Highlights

(DPCs, Salt R&D, GDSA)

Robert MacKinnon
SFWST R&D working group meeting
Las Vegas, Nevada
May 22, 2018



Selected Highlights in Disposal Research: DPCs

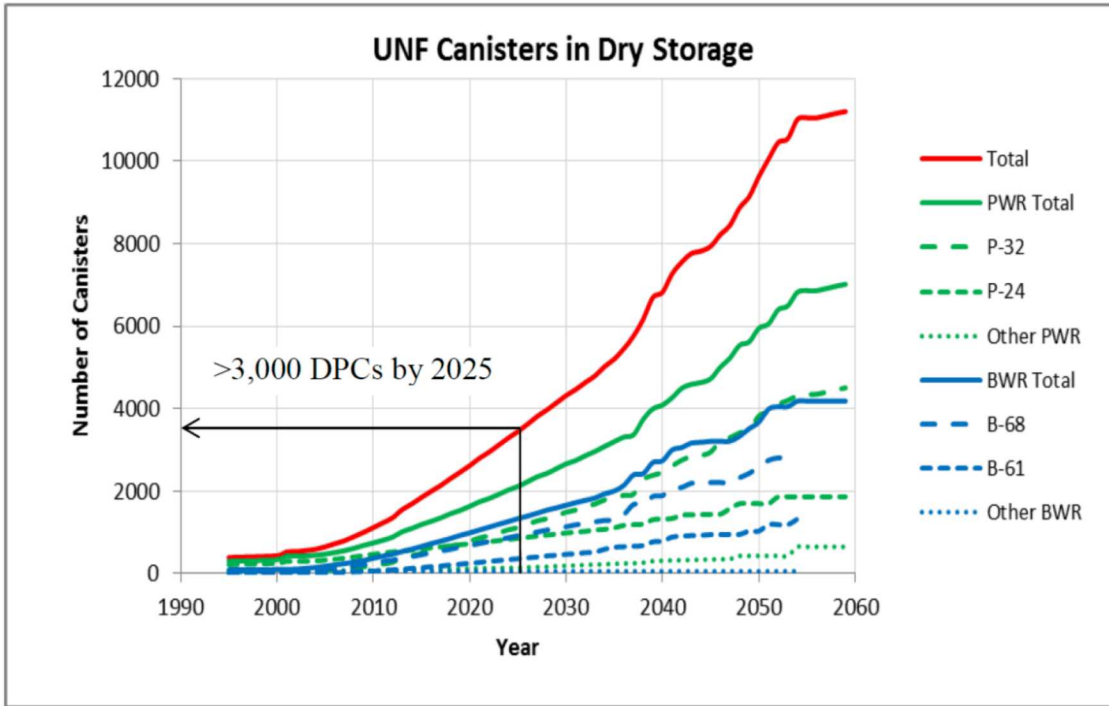

Dry storage canister projection for the U.S., using the TSL-CALVIN logistical simulator (Nutt et al. 2012) and assuming existing power reactors are operated with life-extension licenses

Dual Purpose Storage Cask*

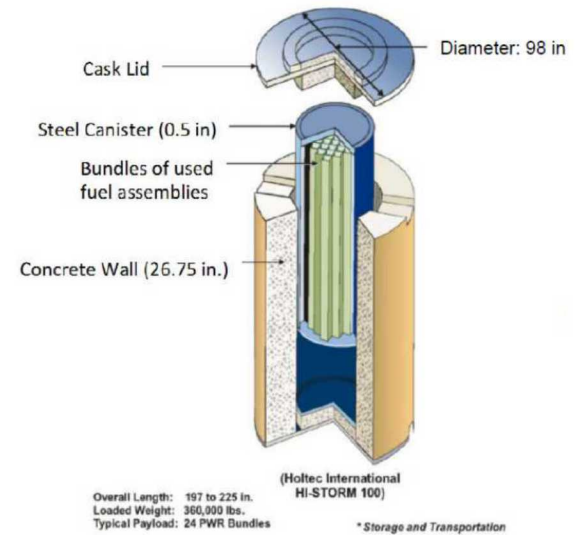

Example of a dual-purpose canister inside a storage overpack (cask) (modified from Easton 2011)

Selected Highlights in Disposal Research: DPCs

■ Technical evaluation results:

- Safety of workers and the public
- Engineering feasibility
- Thermal management
- Postclosure criticality control

No implementation barriers
although all existing DPCs may
not be disposable depending
on the disposal concept *

■ Most favorable concepts: salt and hard rock-unsaturated

- Mainly due to postclosure criticality control (thermal strategy for any medium can be developed)

■ Additional considerations important for direct disposal:

- Disposal overpack reliability estimates can be improved
- DPC design features will impact structural longevity
- Investigate DPC modifications for criticality control (e.g., fillers)
- Investigate screening postclosure criticality on low risk (instead of low probability)

Selected Highlights in Disposal Research: DPCs

- **Technical/Programmatic Solutions for Direct Disposal of SNF in DPCs**
 - Analysis effort
 - Stakeholder engagement
 - Engineering and resource analysis support
- **Probabilistic Post-Closure DPC Criticality Consequence Analysis**
 - Scoping phase
 - Preliminary analysis phase
- **DPC Filler and Neutron Absorber Degradation R&D**
- **Multi-Physics Simulation of DPC Criticality**
 - Scoping phase
 - Preliminary analysis phase



Selected Highlights in Disposal Research: Salt R&D

■ Salt's Benefits as a medium for disposal:

- Impermeable to flow in far field ($\leq 10^{-20} \text{ m}^2$)
- High thermal conductivity ($\sim 5 \frac{\text{W}}{\text{m}\cdot\text{K}}$)
- Relatively dry
- Biologically simple
- Creep closure and healing of excavations/fractures
- Easily mined via continuous miner

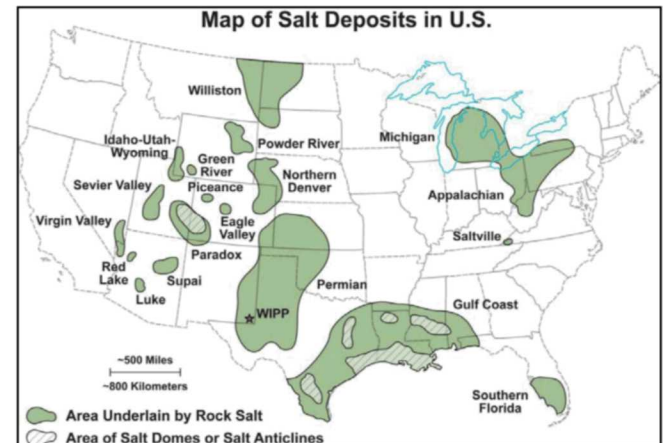

■ Where to Contribute to Salt Technical Basis?

- Disposal of heat-generating waste vs. WIPP
- Bedded vs. domal salt



Selected Highlights in Disposal Research: Salt R&D

Salt R&D is focused on field testing

- Shakedown heater test in existing boreholes (now)
- Heater test in new built-for-purpose boreholes (later this FY)
- Larger scale follow-on demonstrations

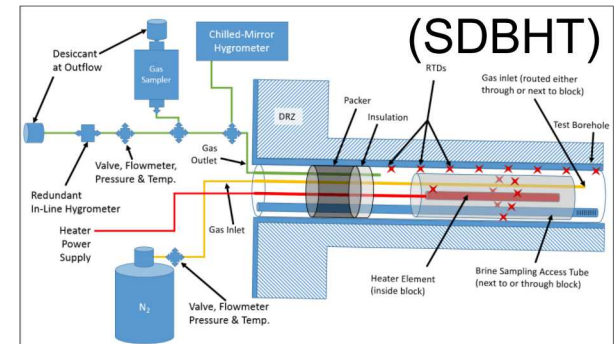

All Salt R&D efforts support field testing

- Numerical modeling to design and interpret results of field test - LANL (FEHM) & LBL (TOUGH-FLAC)
- Laboratory testing to analyze brine/gas/solid samples collected during field test - SNL (solids and liquids) & LANL (liquids and gases)

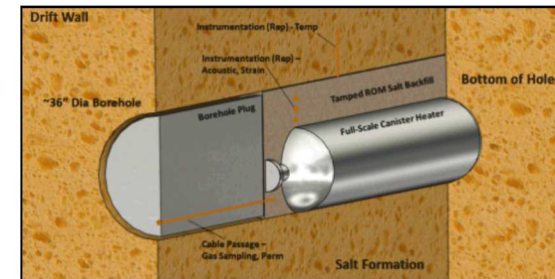

Selected Highlights in Disposal Research: GDSA

- **Objective:** Direct and improved solution to the coupled governing equations over a large heterogeneous domain, including
 - Quantification and propagation of uncertainties, both aleatory and epistemic
 - Direct representation in PA model of significant coupled multi-physics processes in three dimensions (3-D)
 - Realistic spatial resolution of features and processes
 - *Explicit representation of all waste packages*

Key points:

- Less reliance on assumptions, simplifications, and process abstractions
- Adopt a numerical solution and code architecture that can evolve throughout the repository lifecycle (decades!) and is able from the outset to use the most advanced hardware and numerical solvers available

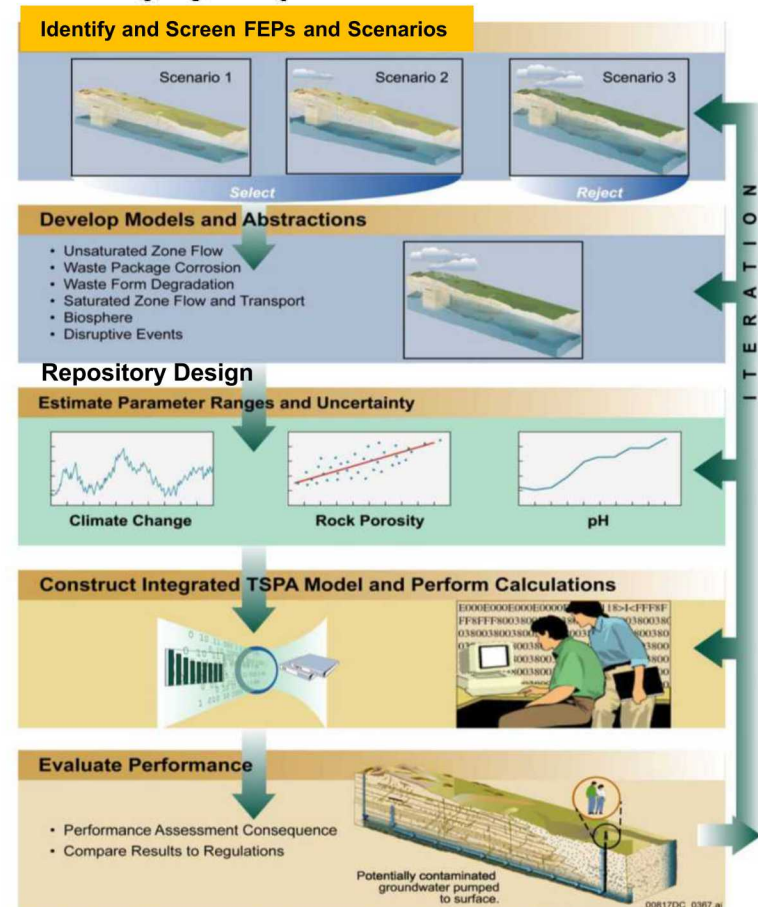



Selected Highlights in Disposal Research: GDSA

GDSA = Geologic Disposal Safety Assessment

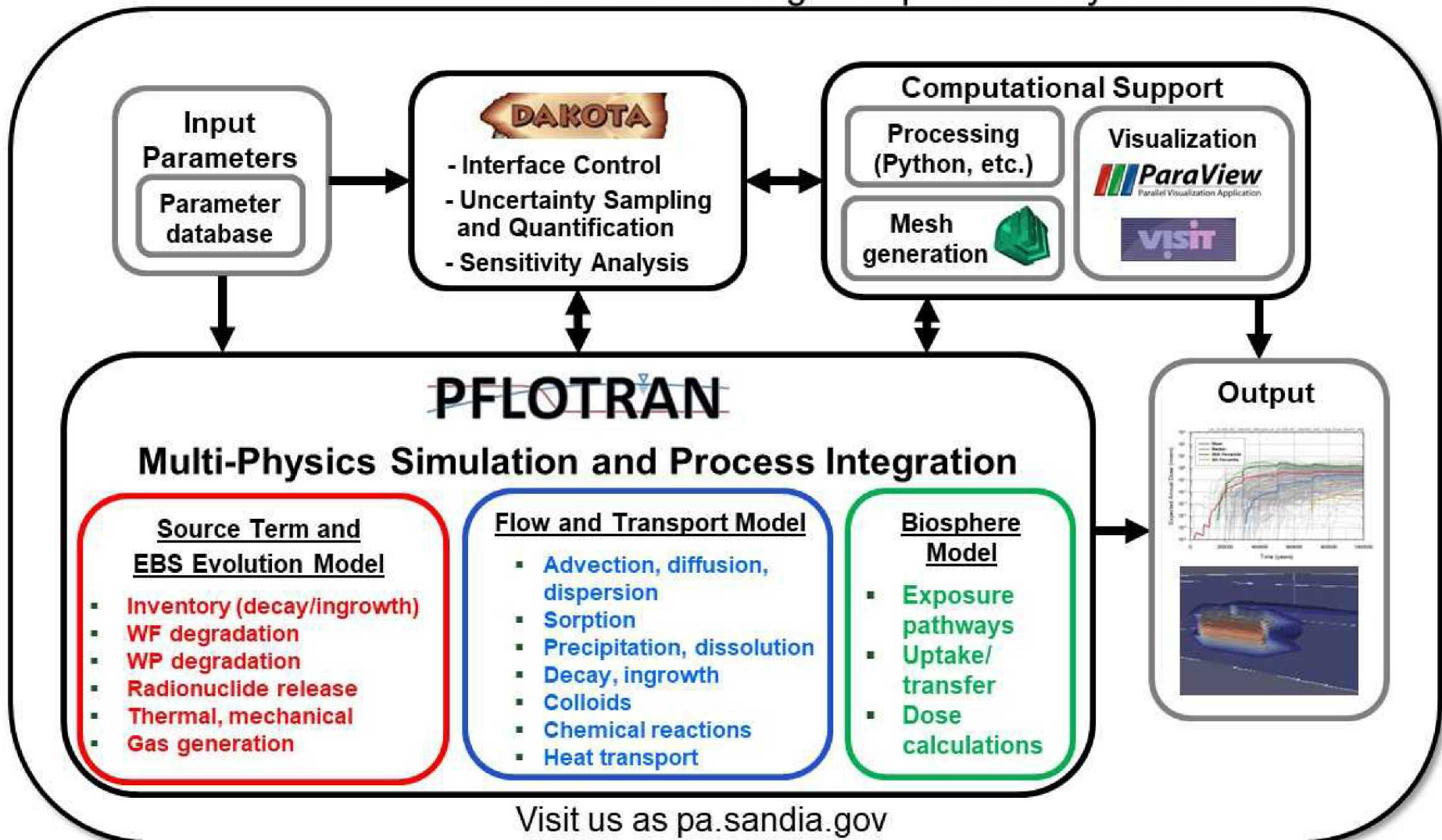

Visit us at pa.sandia.gov