

*Exceptional service in the national interest*

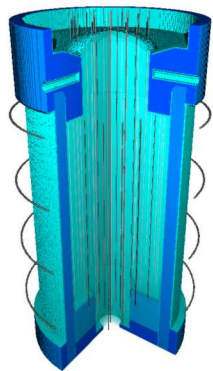
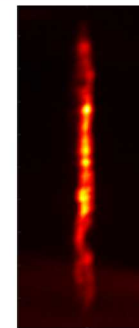
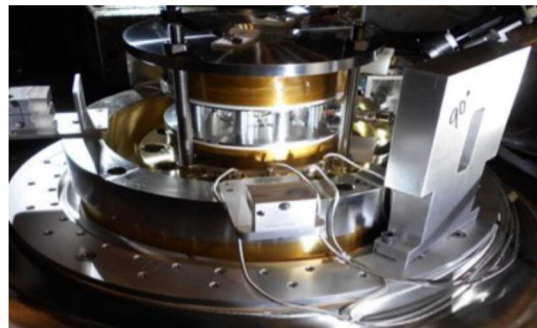
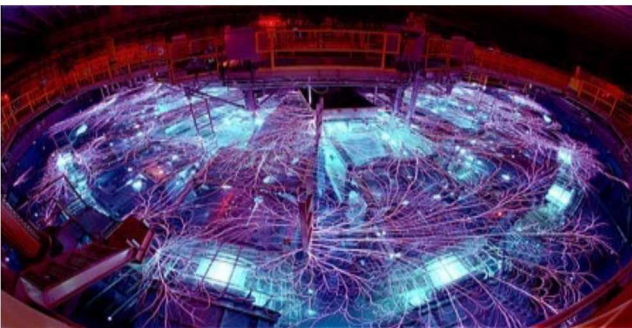

# Progress and Plans in Magnetized Liner Inertial Laser Fusion Research

磁化衬板惯性激光融合研究进展与计划

Kyle Peterson

ICMRE 2018

# MagLIF is a broad collaboration

MagLIF是一个广泛的合作

D. Ampleford, T.J. Awe, C.J. Bourdon, G.A. Chandler, P.J. Christenson, M.E. Cuneo, M. Geissel, M. Glinsky, M.R. Gomez, K.D. Hahn, S.B. Hansen, E.C. Harding, A.J. Harvey-Thompson, M.H. Hess, C.A. Jennings, B. Jones, M. Jones, P.F. Knapp, D.C. Lamppa, J.S. Lash, M.R. Martin, T.N. Nagayama, K.J. Peterson, J.L. Porter, P. Rambo, G.A. Rochau, D.C. Rovang, C.L. Ruiz, S.E. Rosenthal, M.E. Savage, P.F. Schmit, J. Schwarz, D.B. Sinars, S.A. Slutz, I.C. Smith, W.A. Stygar, R.A. Vesey, M. Weis, E.P. Yu., G. Logan

***Sandia National Laboratories***

R. Paguio, K. Tomlinson, H. Huang, M.S. Wei

***General Atomics***

J. Davies, R. Betti, P.Y. Chang, G. Fiksel, D. Barnak, V. Glebov, E.M. Campbell, A.B. Sefkow

***Laboratory for Laser Energetics***

B. Pollock, D. Strozzi, C. Goyon, J. Moody, S. Khan, D. Hinkel, M.C. Herrmann

***Lawrence Livermore National Laboratory***

# Summary

## 概要

- The performance of MagLIF targets has improved to produce  $1.1e13$  neutrons from deuterium fuel
  - Improvements to laser heating
  - Improved liner stability with higher velocity
  - Higher fuel density with less convergence
- We are working to develop platforms capable of delivering more drive current, higher initial magnetic fields, and more preheat energy simultaneously to test performance scaling on Z
- A significant effort is underway to understand sources of mix and impact on performance
- Significant variability in performance is observed in some of our experiments, we are working to understand this
- We are evaluating ignition scale laser energy coupling (30kJ) at NIF

# Magneto-inertial fusion attempts to operate in an intermediate fuel density space between MCF and ICF

磁惯性聚变试图在中间的燃料密度空间中运行

## Strategy:

- Reduce fuel density to suppress radiation losses
- Use a magnetic field to suppress the thermal conduction losses during compression
- Reduce required target convergence

## Requirements:

- Magnetized fuel
- Pre-heated fuel
- Compression system
  - Pre-heated and pre-magnetized plasma compressed until fusion is achieved

CG-100-0126 (11-05)

### Magnetized Target Fusion

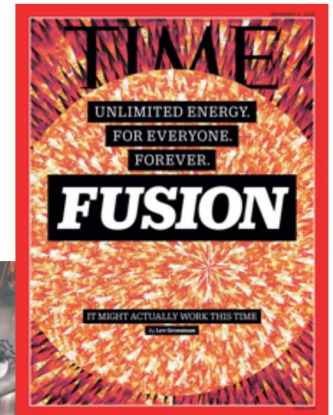
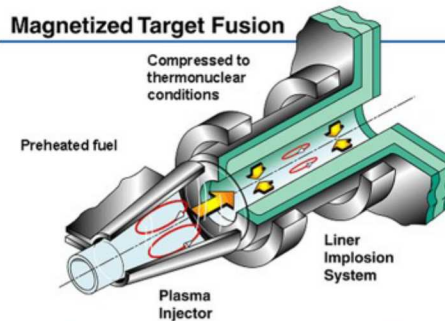

General Fusion

# Magneto-inertial fusion utilizes magnetic fields to relax the stagnation requirements of ICF

磁惯性融合利用磁场来缓解ICF的停滞需求

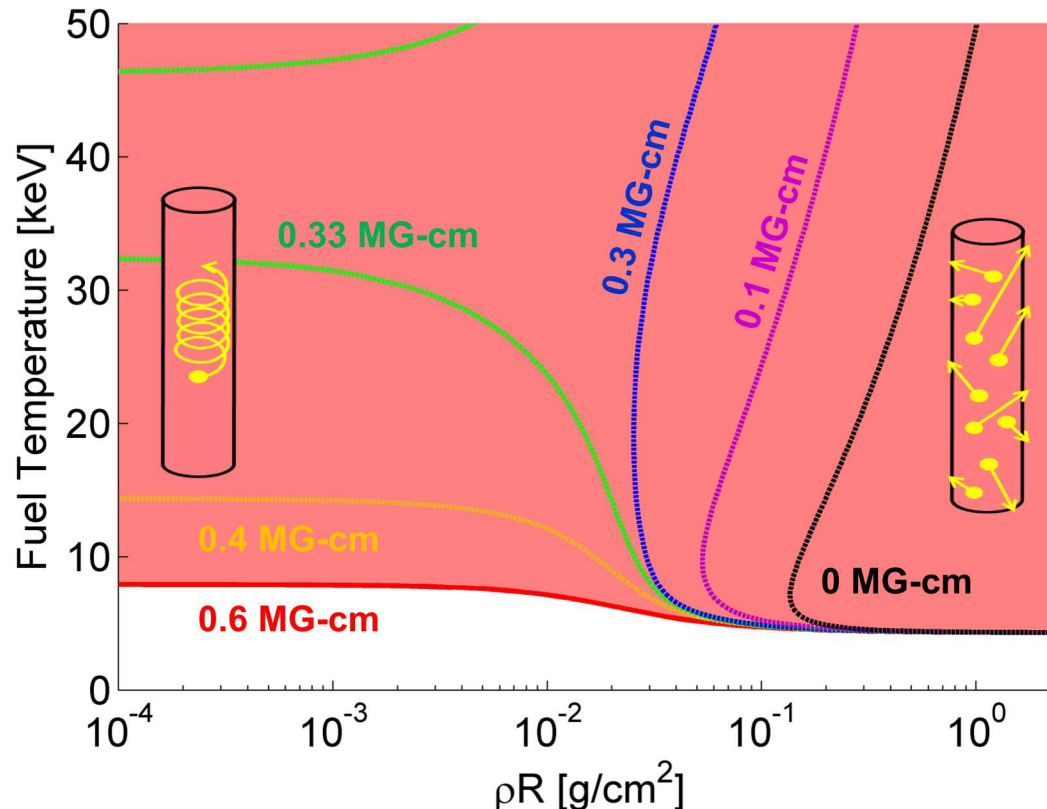

- With a high enough magnetic-field-radius product, charged fusion products become trapped
- This relaxes the areal density requirement of the fuel
- Good performance is possible over a much larger region of parameter space

# Magnetized Liner Inertial Fusion relies on three stages to produce fusion relevant conditions

磁化衬里惯性聚变依靠三个阶段产生融合相关条件

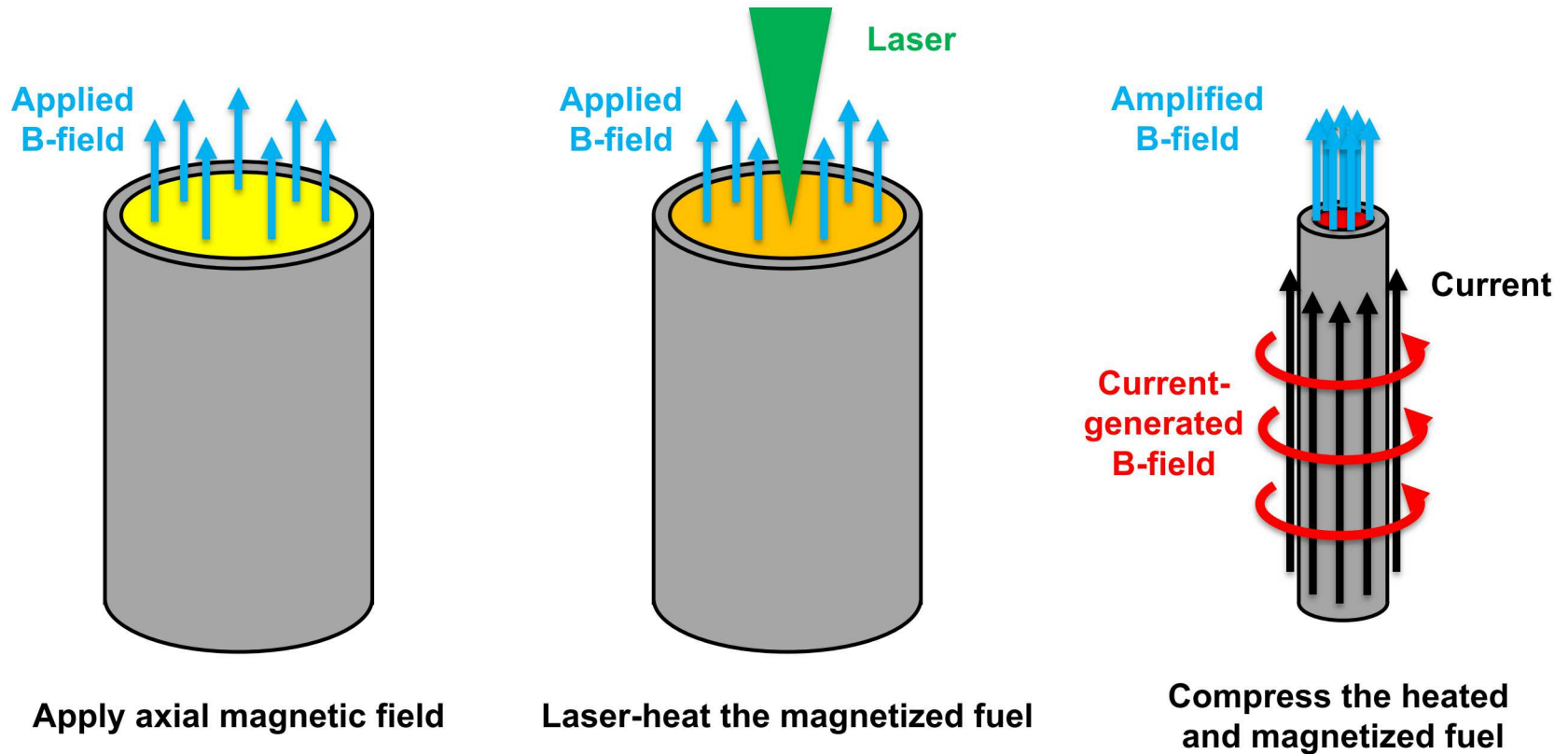

# An axial magnetic field is applied with external field coils before the implosion occurs

在内爆之前，外部磁场线圈施加轴向磁场

Helmholtz-like coils apply 10-30 T in 3.5 ms

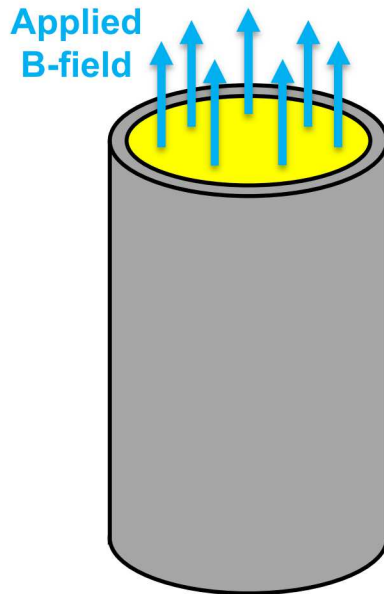

Apply axial magnetic field

- Metal cylinder contains 0.7 mg/cm<sup>3</sup> of deuterium gas
- 10 mm tall, 5 mm diameter, 0.5 mm thick

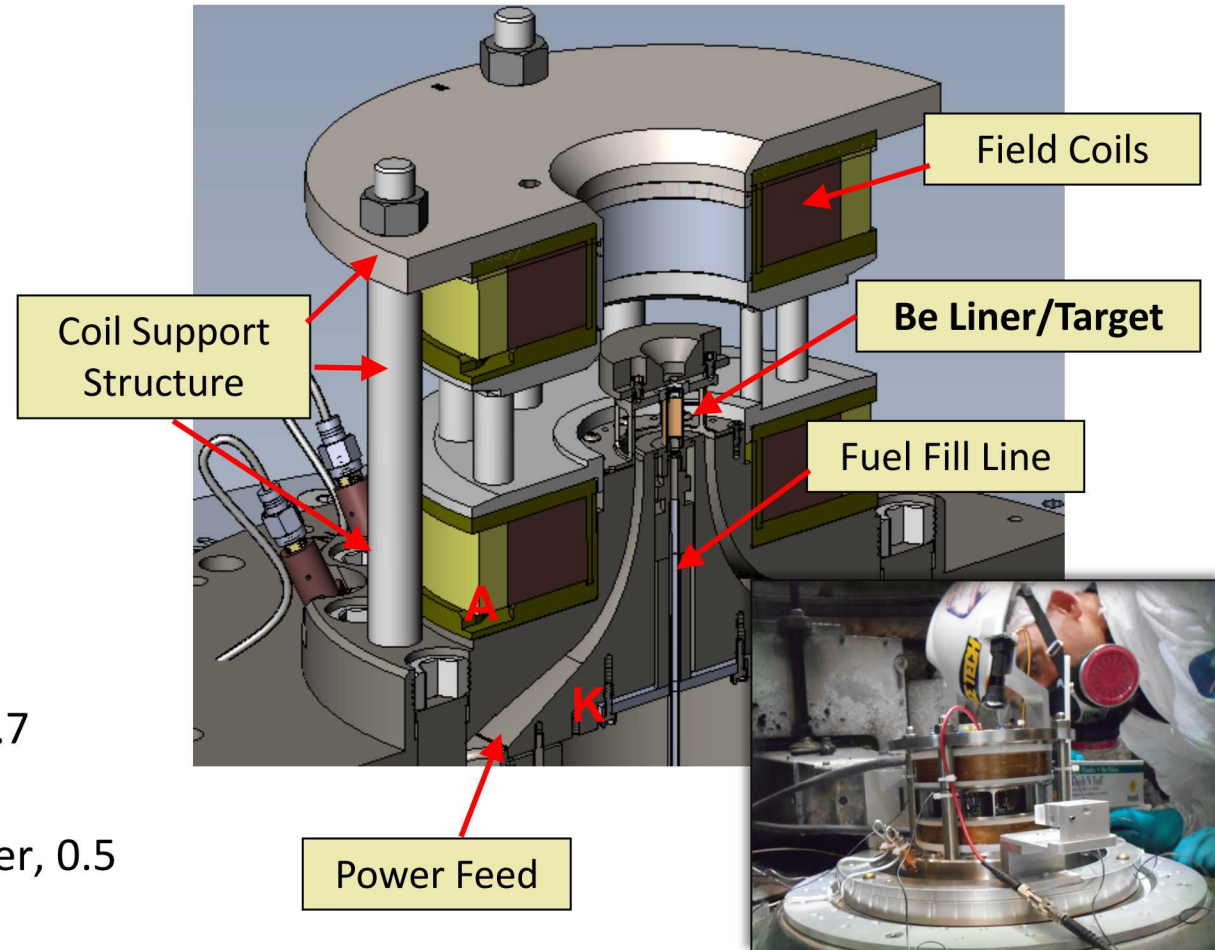

# A laser is used to heat the fuel at the start of the implosion

在内爆开始时使用激光来加热燃料

527 nm, 2 ns, 1-4 kJ laser used to preheat the fuel

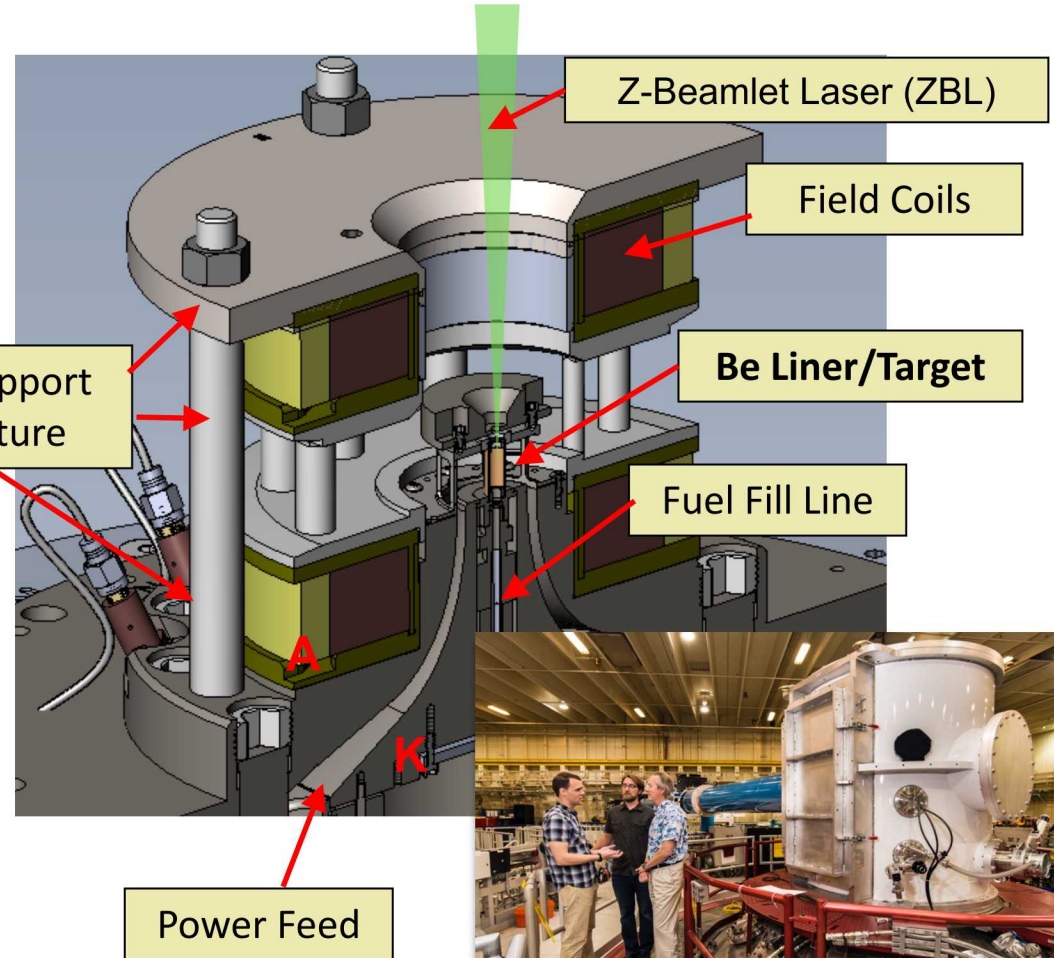
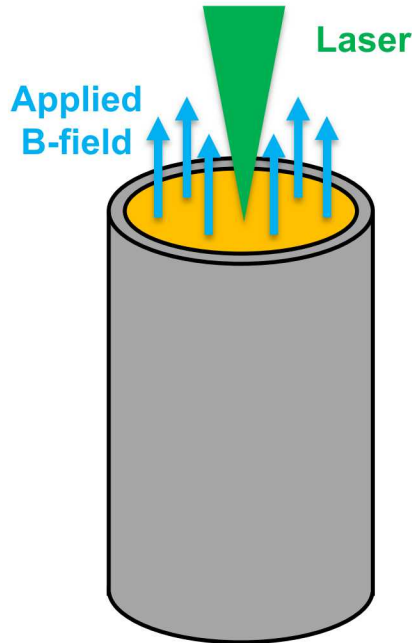

Laser-heat the magnetized fuel

- Laser must pass through 1-3  $\mu\text{m}$  thick plastic window
- Significant laser energy can be deposited in the plastic

# The current from the Z machine is used to implode the target

来自Z机器的电流用于内爆目标

Z drives axial ~17 MA axial current, risetime is 100 ns

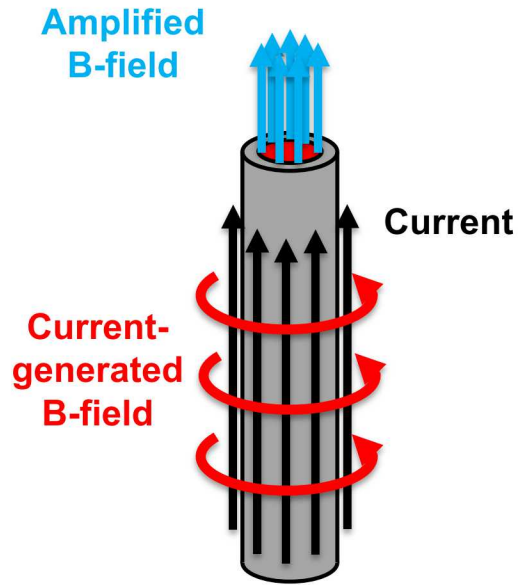

Compress the heated and magnetized fuel

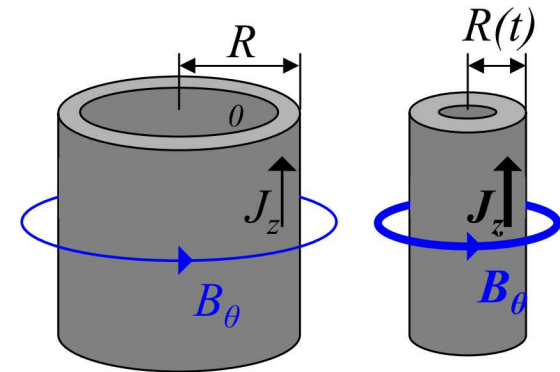
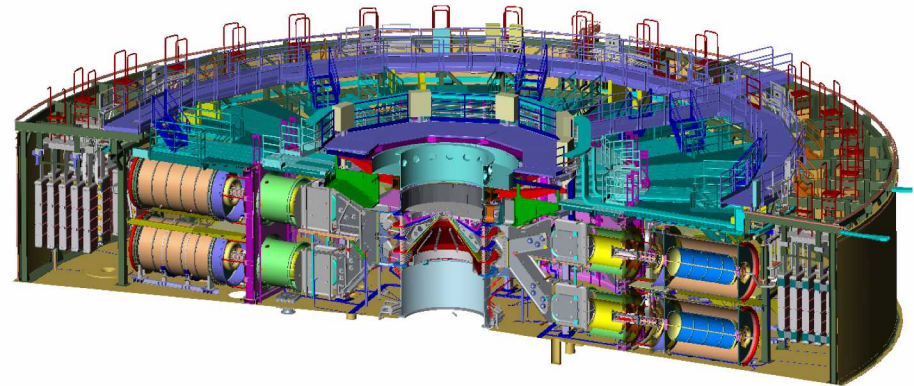

- Metal cylinder implodes at ~70 km/s
- Fuel is nearly adiabatically compressed
- Axial magnetic field is compressed to 1-10 kT

$$P = \frac{B^2}{8\pi} = 105 \left( \frac{I_{MA}/26}{R_{mm}} \right)^2 \text{ MBar}$$

# Fully-integrated (Bz+Laser+Z) 3-D HYDRA calculations illustrate the stages of a MagLIF implosion

全集成 (Bz + 激光 + Z) 三维HYDRA计算说明了MagLIF内爆的阶段

DB: hydrg00333.root  
Cycle: 333 Time: 0.065021

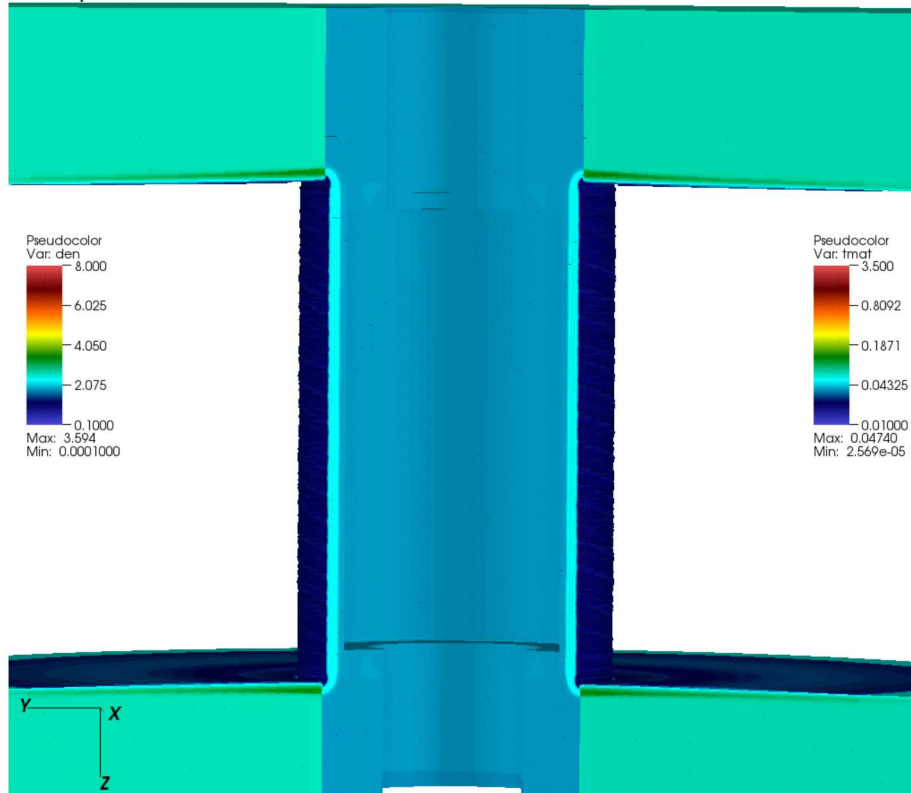

Simulation by A. Sefkow

1-D picture\*

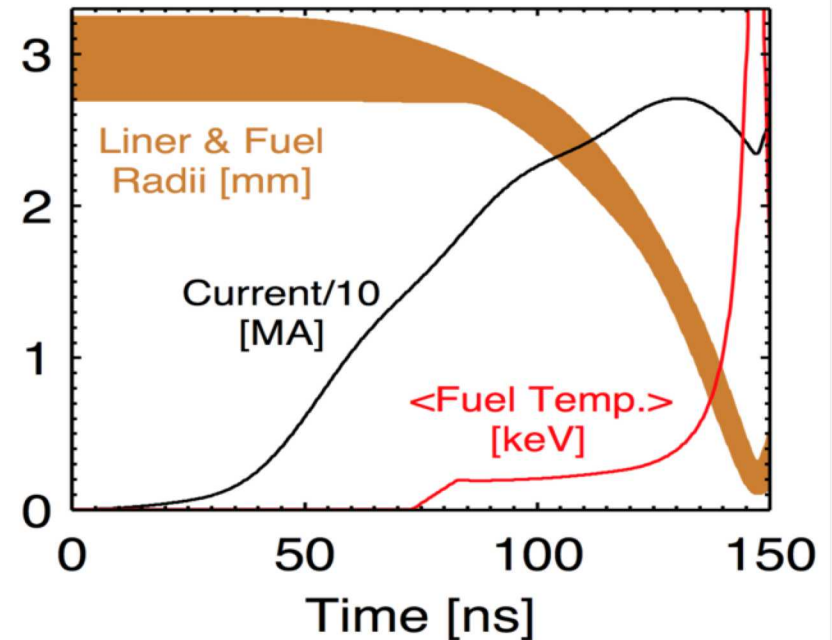

# Initial integrated experiments on Z demonstrated that the fundamental concepts of MagLIF work

Z初步的综合实验证明了MagLIF的基本概念

High Convergence Implosion

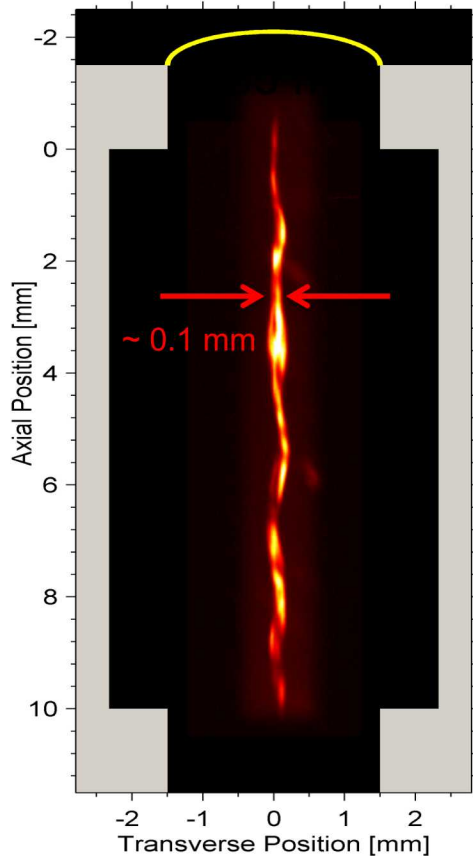

6+9 keV Emission Image  
CR > 40

B-field Flux Compression & Magnetic trapping of charged particles

Secondary DT Spectrum

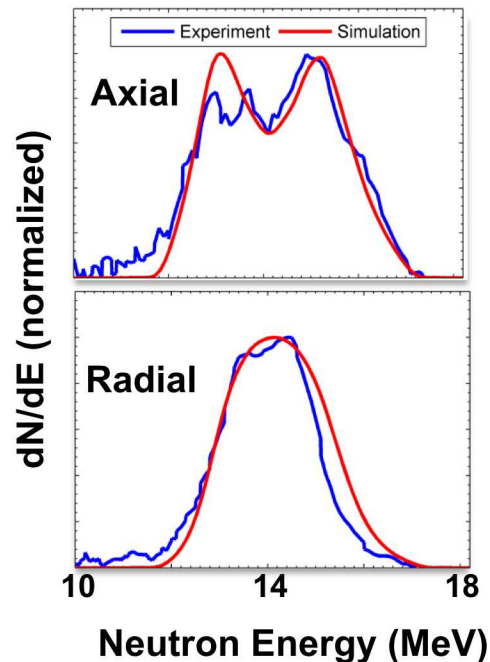

DT Secondary Spectra  
BR > 0.35 MG-cm

Thermonuclear Neutrons

Reactivity Scaling vs.  $T_i$

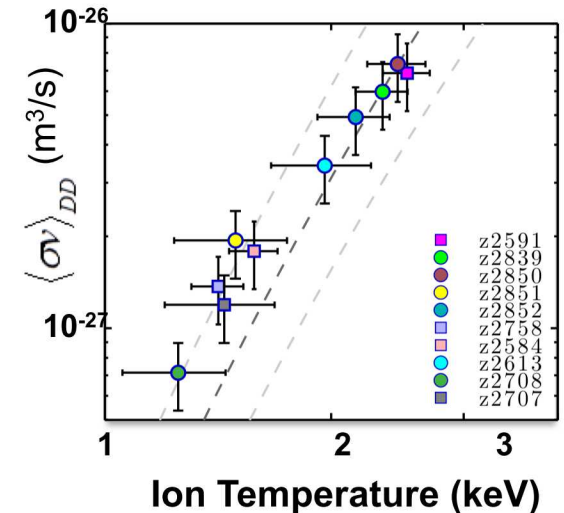

$$Y_{DD} = \frac{1}{2} n_D^2 \langle \sigma v \rangle_{DD} V \tau$$

Yield, Volume, Duration  
Consistent with DD reactivity

# We have verified that good performance requires both applied B-field and laser heating

我们已经证实，良好的性能需要应用B场和激光加热

Significant yields and temperatures only w/ applied  $B_z$  and preheat

	No B-field	B-field	
No Laser Heating	$3 \times 10^9$	$1 \times 10^{10}$	DD Neutron yield
Laser Heating	$4 \times 10^{10}$	$3 \times 10^{12}$	

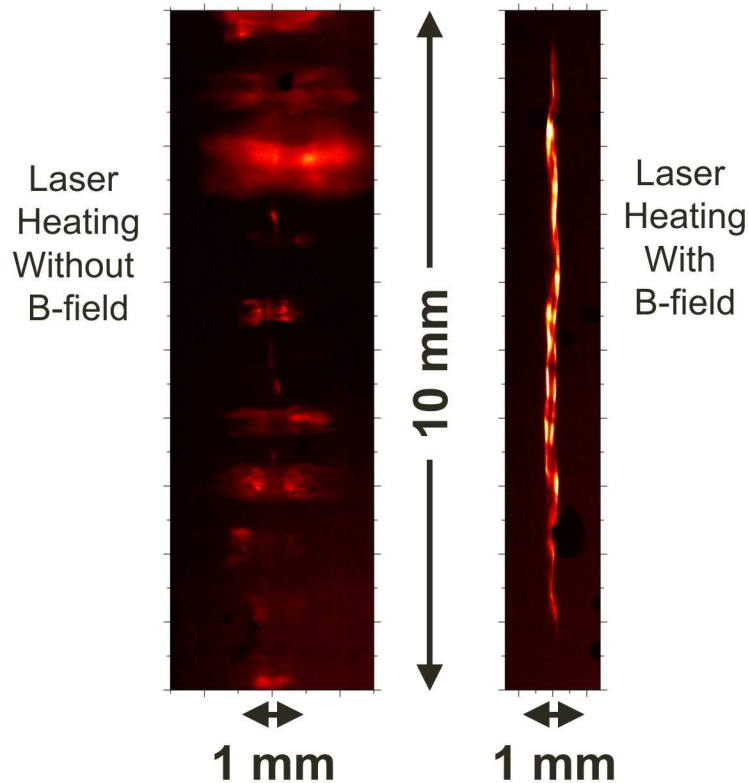
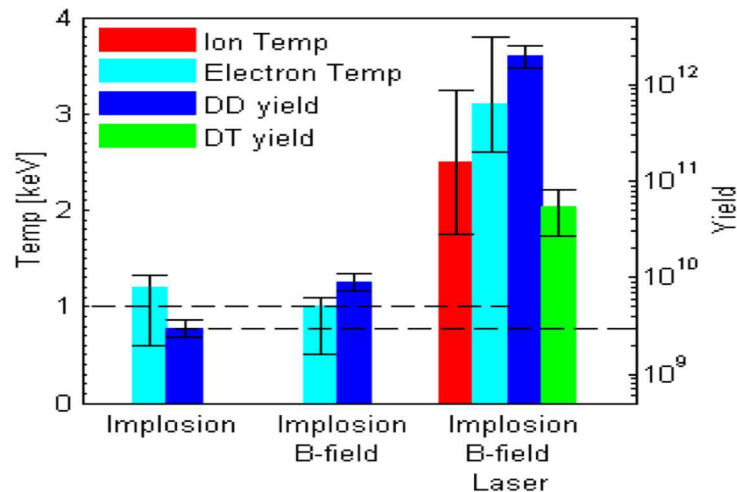

$3 \times 10^{12}$  is a DT-equivalent yield of ~0.6 kJ

# Our initial experiments had significant uncertainty in the coupled laser energy

我们最初的实验在耦合激光能量方面有很大的不确定性

- Significant laser plasma interactions (LPI), not modeled in our codes
- No beam smoothing
- Several independent laser heating experiments suggested low laser energy coupling to fuel
  - Window transmission
  - X-ray emission
  - VISAR blastwave analysis
- Initial experiments assumed to be preheat starved

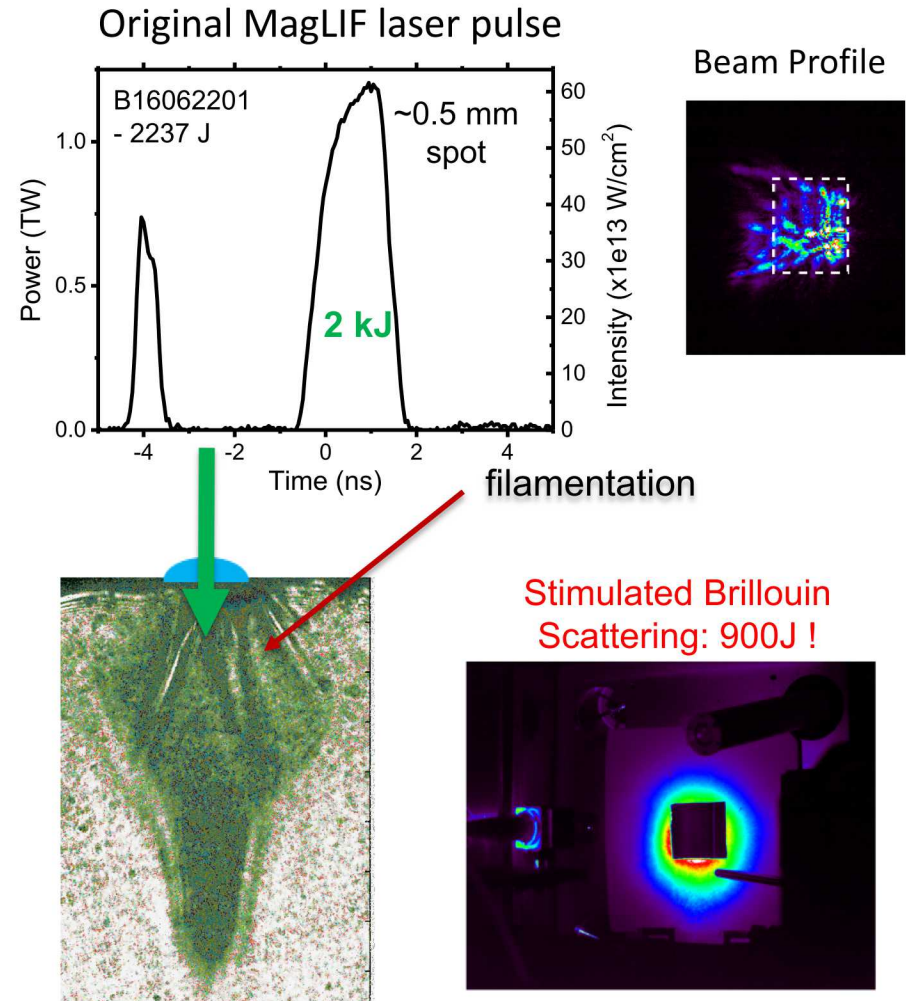

# Phase plate beam smoothing and reduced intensities led to significant improvements in fuel pre-heating

相位板光束平滑和强度降低导致燃料预热显著提高

## Optical Blastwave Measurements

### Original MagLiF Configuration

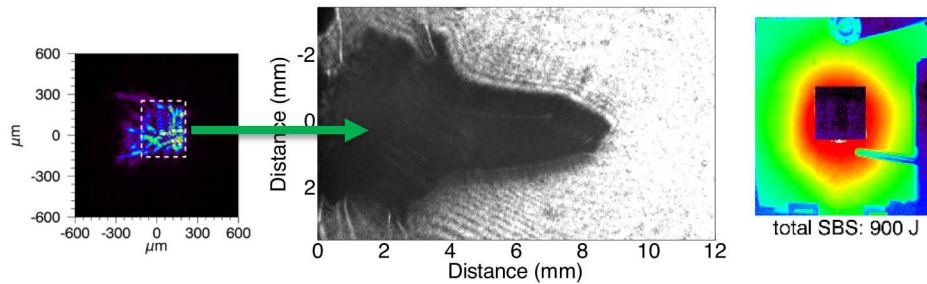

### Laser Config A

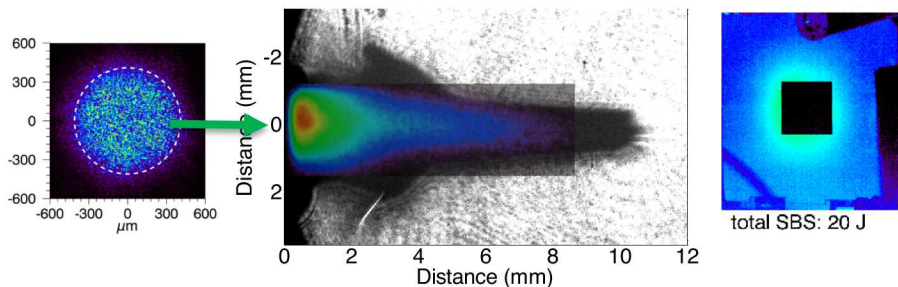

- 1100  $\mu\text{m}$  Distributed Phase Plate
- Lower laser intensity
- 80 J pre-pulse, 1500J 4ns main pulse

- Reduced SBS from  $\sim 50\%$  to  $< 3\%$
- Enhanced penetration depth with **reduced** laser energy

Simulations matched total energy deposited, but still did not match energy deposition profile

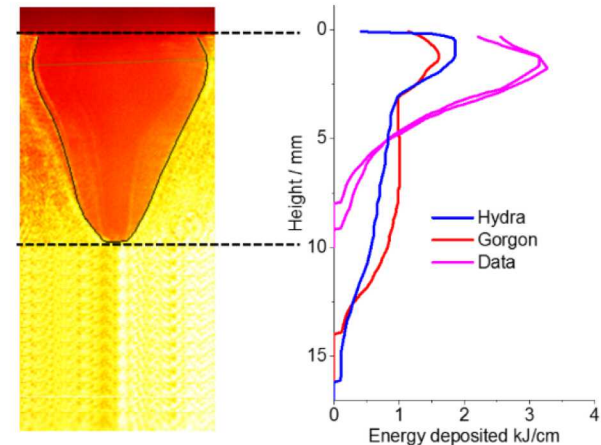

# These improvements led to modest improvements in performance, but significantly increased variability

这些改进导致性能略有改善，但显著提高了可变性

- Initial experiments with low preheat were reasonably reproducible and consistent with simulations
- As preheat was increased, significant variation in performance was observed
  - Laser preheat configuration ?
  - Liner instabilities (CR>40) ?
  - Mix cliff ?

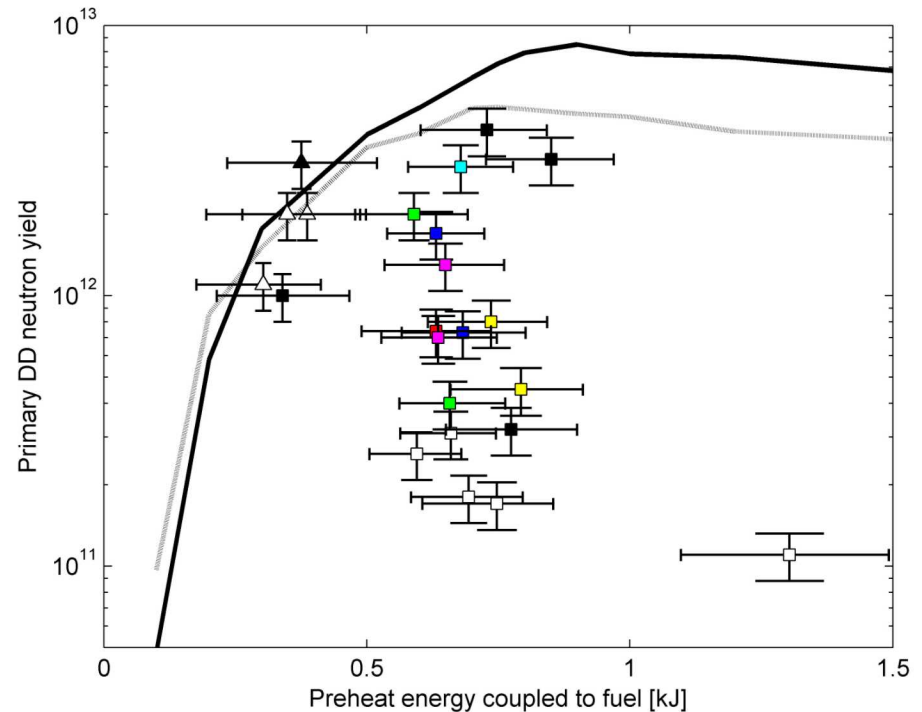

# Some shot-to-shot variation is observed in laser heating when phase plates are used. Are these differences significant?

在使用相位板时激光加热中观察到一些镜头间的变化。这些差异是否显著？

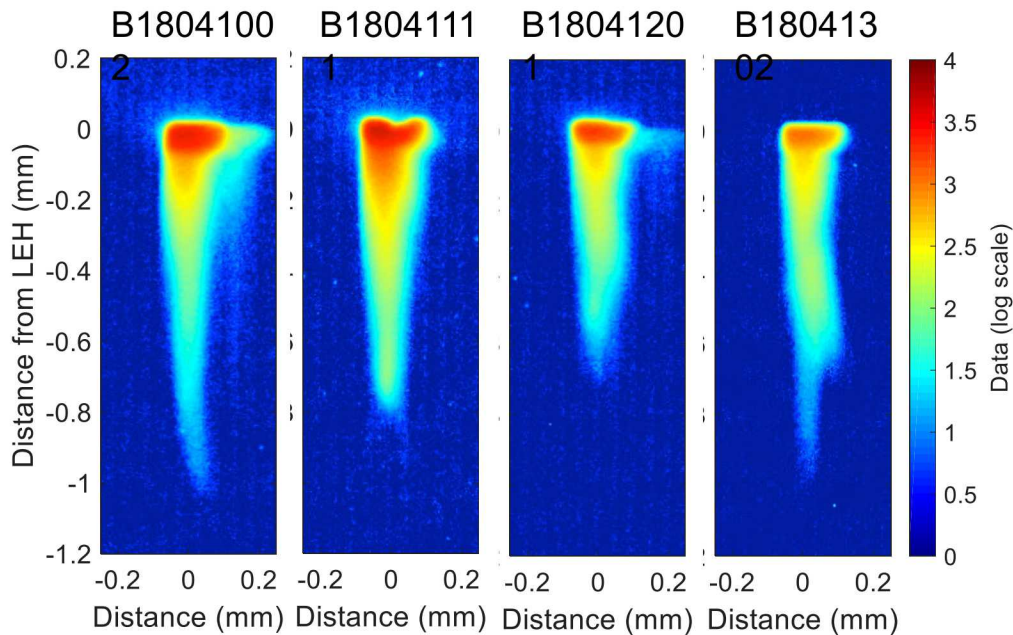

100  $\mu$ m pinhole filtered with 1 mil kapton

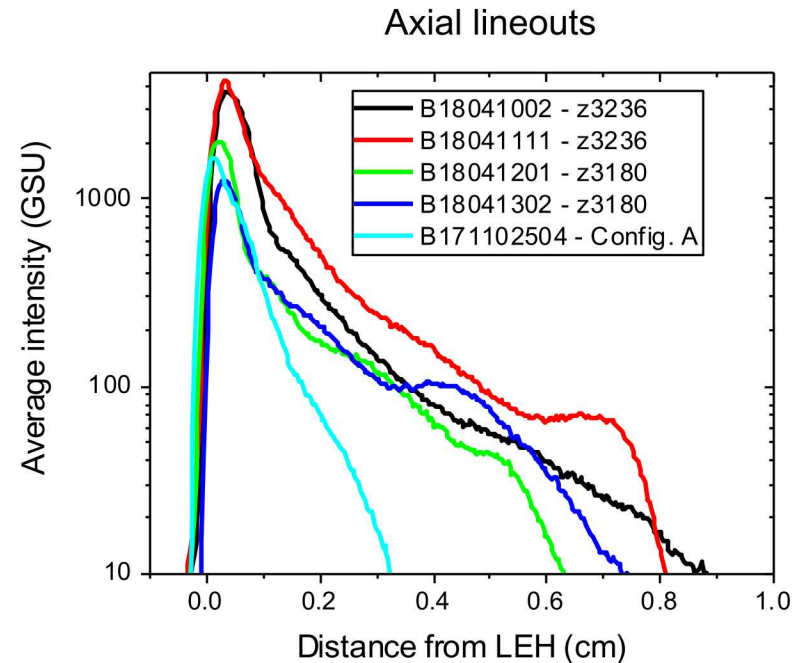

# Several potential sources of performance variation due to laser heating are being explored

正在探索由激光加热引起的几种潜在的性能变化来源

- Dust is one of the leading hypotheses
- Simulations suggest  $>50 \mu\text{m}$  dust particles can substantially affect laser deposition
- Significant number of dust particles  $10\text{-}100 \mu\text{m}$  in size have been observed on windows
- Chances of interaction increase with larger laser spot size
- New protocols are being put in place to control and monitor dust in our experiments



Dust particles measured on typical window

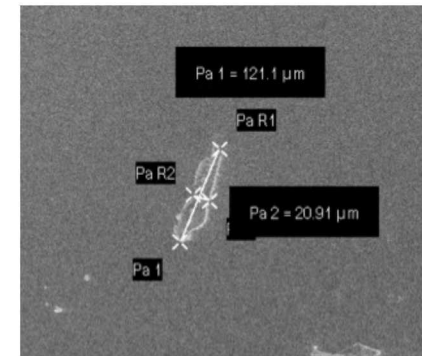

2D Hydra simulation

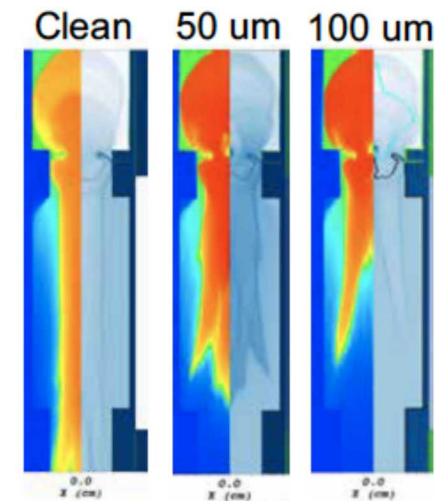

# OMEGA-EP experiments showed increased dwell time between laser prepulse and main pulse was needed

OMEGA-EP实验显示需要增加激光脉冲和主脉冲之间的停留时间

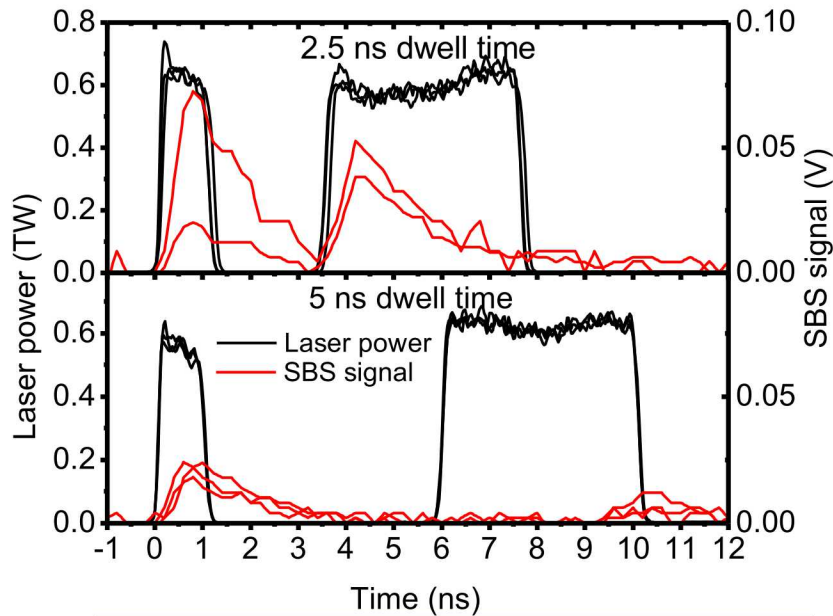

Laser power and SBS signals for two different pulse shapes

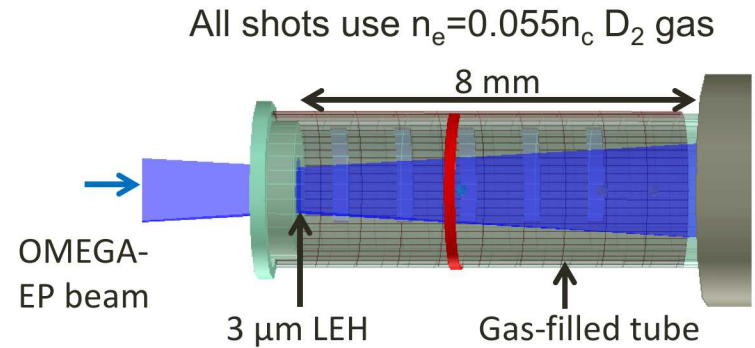

# Longer delay times were recently enabled by co-injection of the Z Petawatt laser.

通过共同注入Z Petawatt激光器最近实现了更长的延迟时间。

- Utilize 10-20J Z-Petawatt laser pulse to disassemble window
- Entire 6 ns ZBL laser window available for fuel heating
- Significantly improved energy coupling and reduced LPI effects

Optical Shadowgraph  
@ +20ns

Time integrated  
pinhole camera

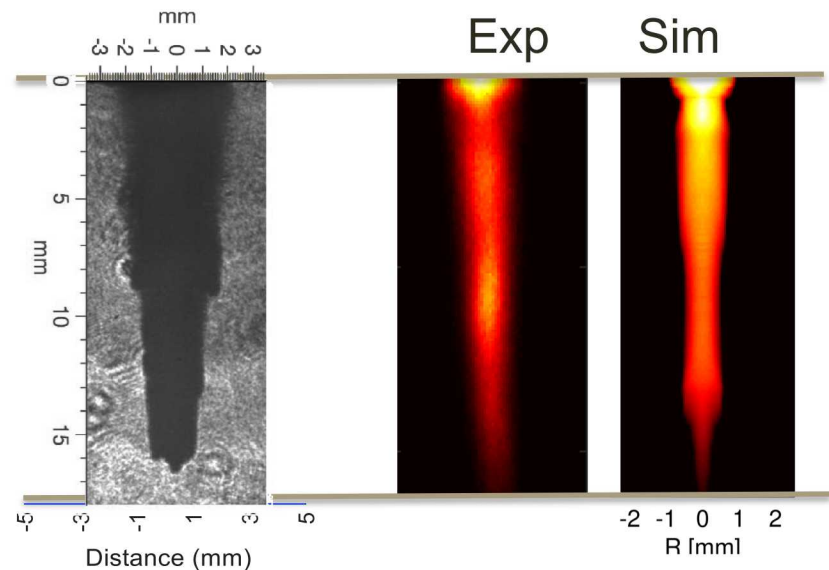
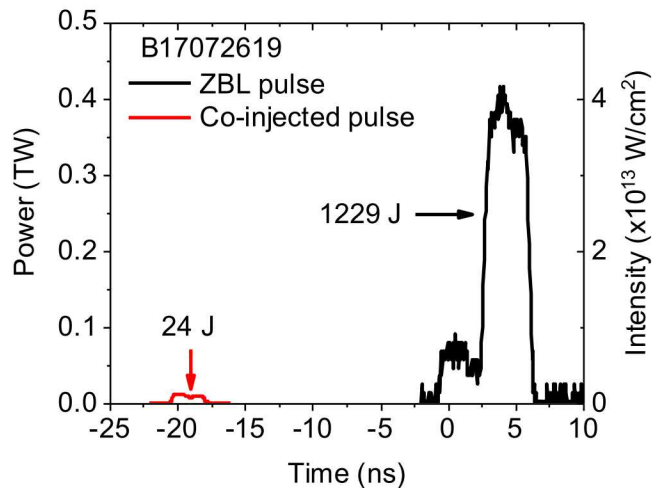

# Co-injection also mitigates window mix, consistent with simulations

与模拟一致，共注射还可以缓解窗口混合

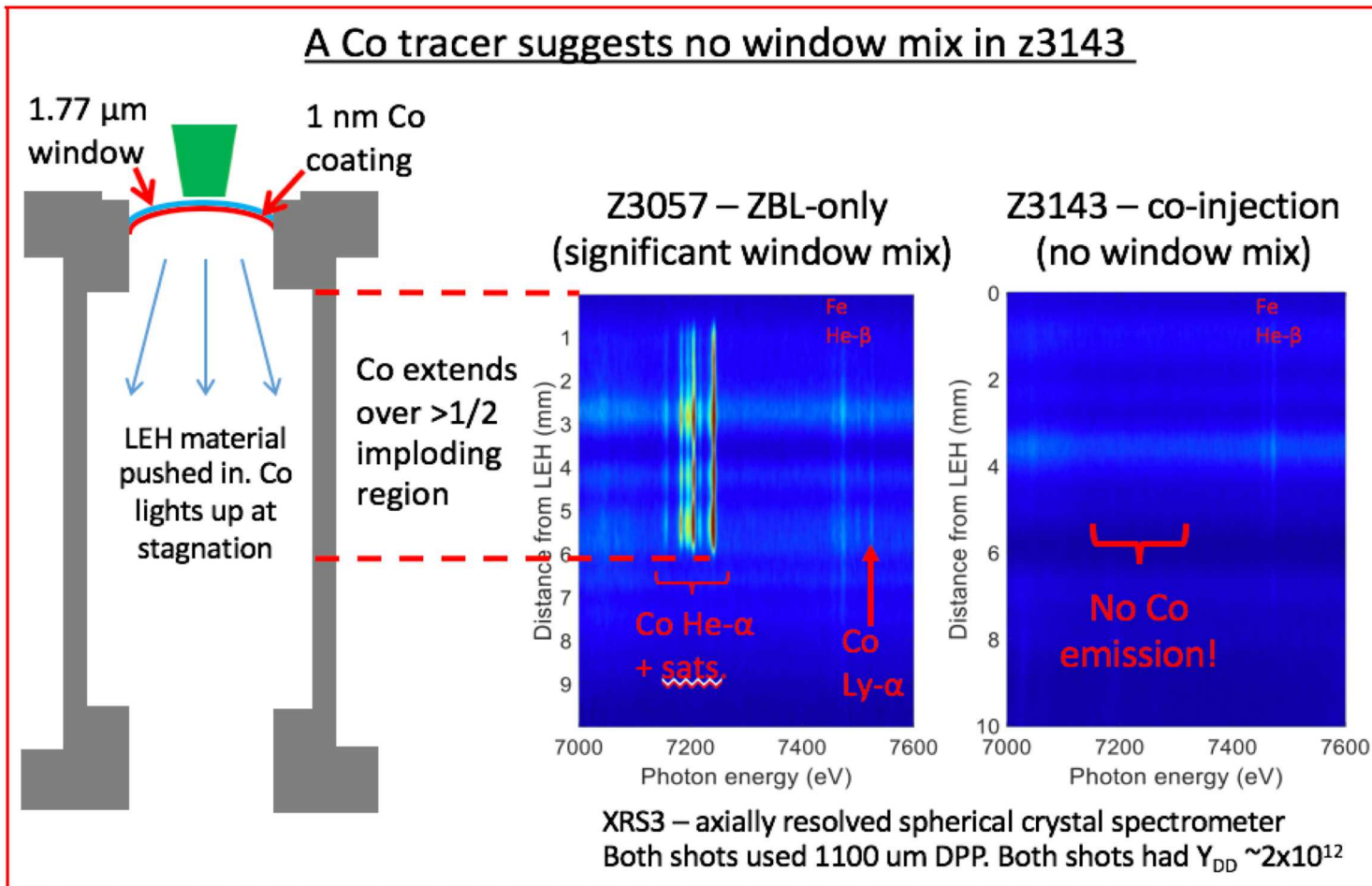

# We are still working to understand the full impact of 3D instabilities on performance

我们仍在努力理解3D不稳定性对性能的全面影响

- Spectroscopic measurements suggest relatively high levels of mix
- Experiments with higher convergence generally have poorer performance
- Disruption due to instabilities?
- 3D simulations have matched experimental observables with quasi-2D pressure profiles
- Thicker liners (less feedthrough) have **decreased** performance

>6keV, time time integrated high resolution X-ray self-emission stagnation image

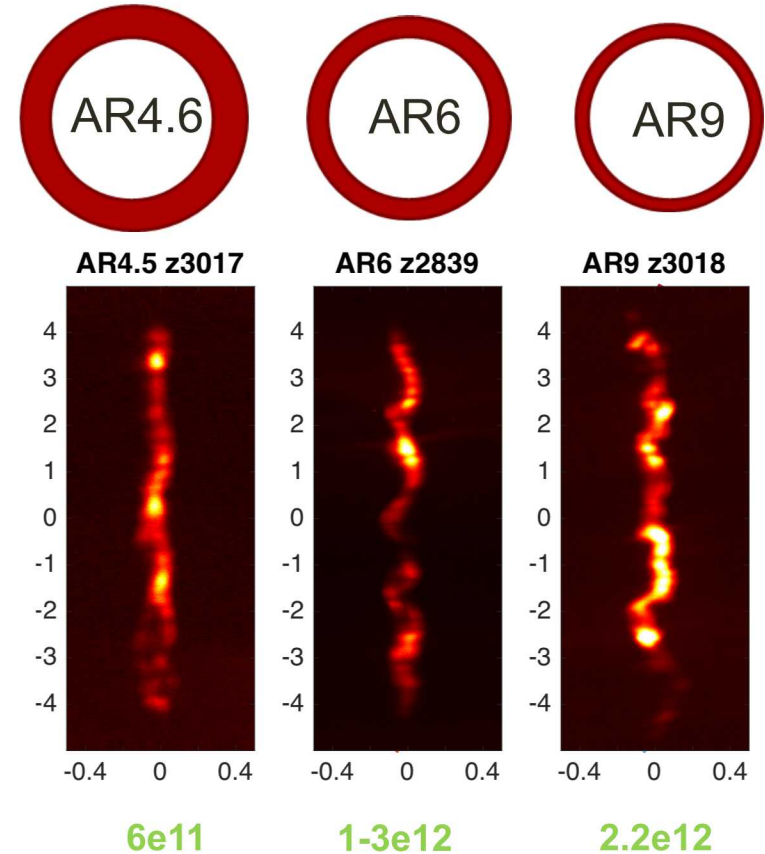

AR = Liner Radius/Liner Thickness

# Significant improvements in liner stability have been demonstrated with thick dielectric coatings

厚电介质涂层已经证明了衬管稳定性的显著改进

>6keV X-ray self-emission stagnation images

- Thick plastic coatings applied to outside surface mitigate electro-thermal instability growth
- Coated AR-9 targets have shown excellent stability and shot-to-shot reproducibility (~15%)
  - Higher magnetization observed ( BR ~ 400 kG cm )

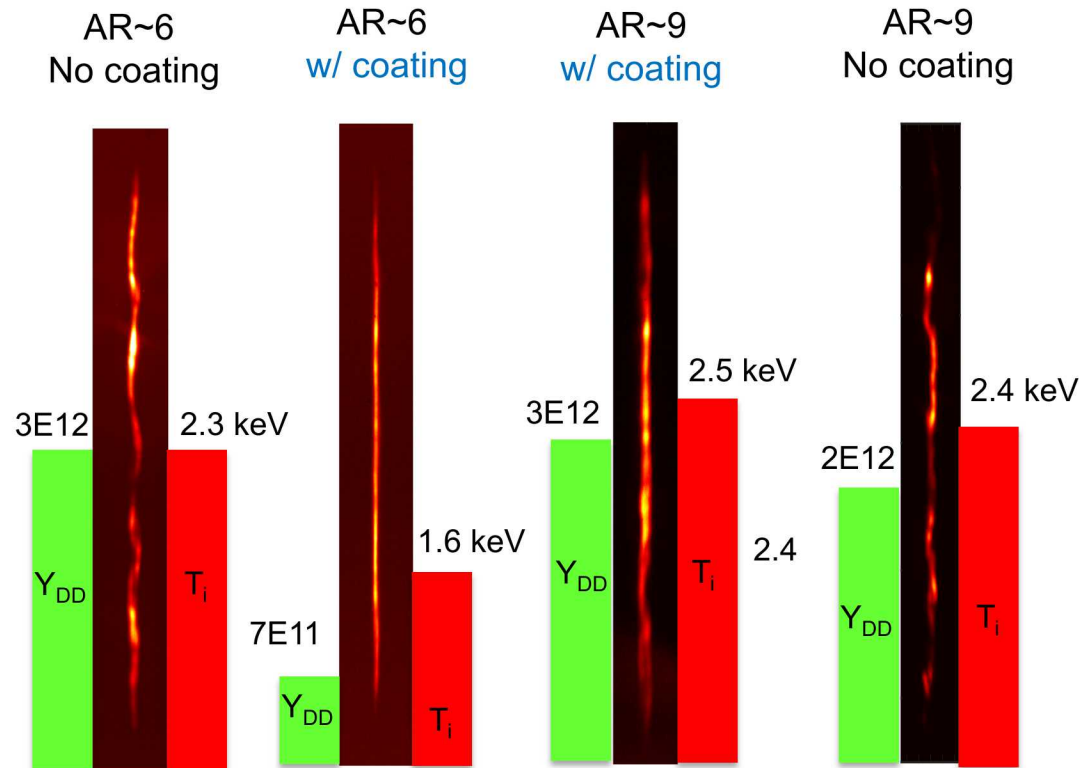

Observed differences in liner morphology do not appear to be strongly affecting stagnation performance

# We recently demonstrated $1.1e13$ DD neutrons with improvements to preheating and liner stability

我们最近证明  $1.1e13$  DD 中子具有改进的预热和衬管稳定性

	z3236 (preheat 18A)
Main pulse laser energy	261 + 2240 J
Gas pressure	90 psi (1 mg/cc)
LEH window	2 mm diam. 1.77 $\mu$ m
Dopant	1 nm Co on LEH
DD	$1.1e13 \pm 20\%$
DD/DT	100 +/- 28%
Tion (Ntof)	3.1 keV +/- 20%

10T, 17 MA Current Pulse

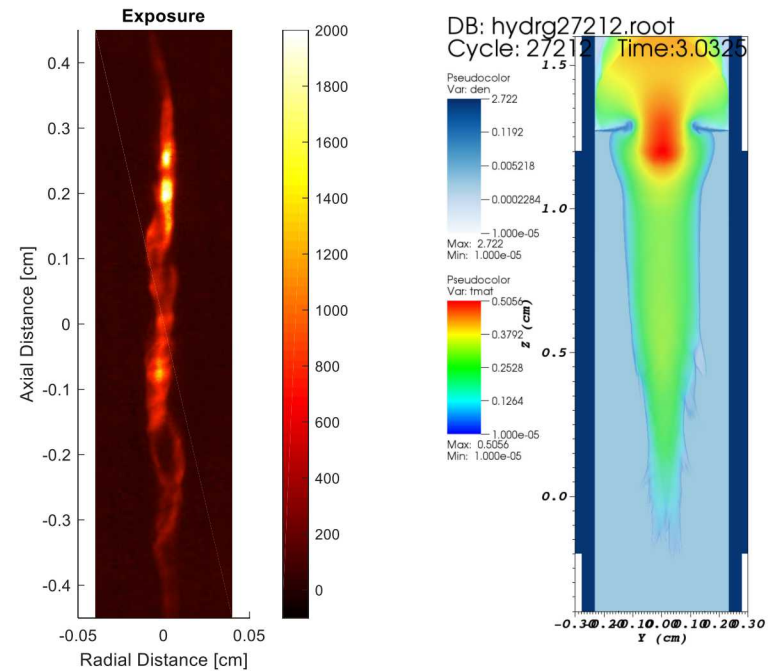

- AR9 Coated/Stabilized Liner
- Higher density fuel (1.0 mg/cc)
  - Lower convergence
- Greater coupled preheat energy
  - 1.5kJ with co-injection
- **Still need to reproduce this result**

# Simulations suggest that increased initial magnetization levels are best path for increased performance on Z

仿真表明，提高初始磁化水平是提高Z性能的最佳方法

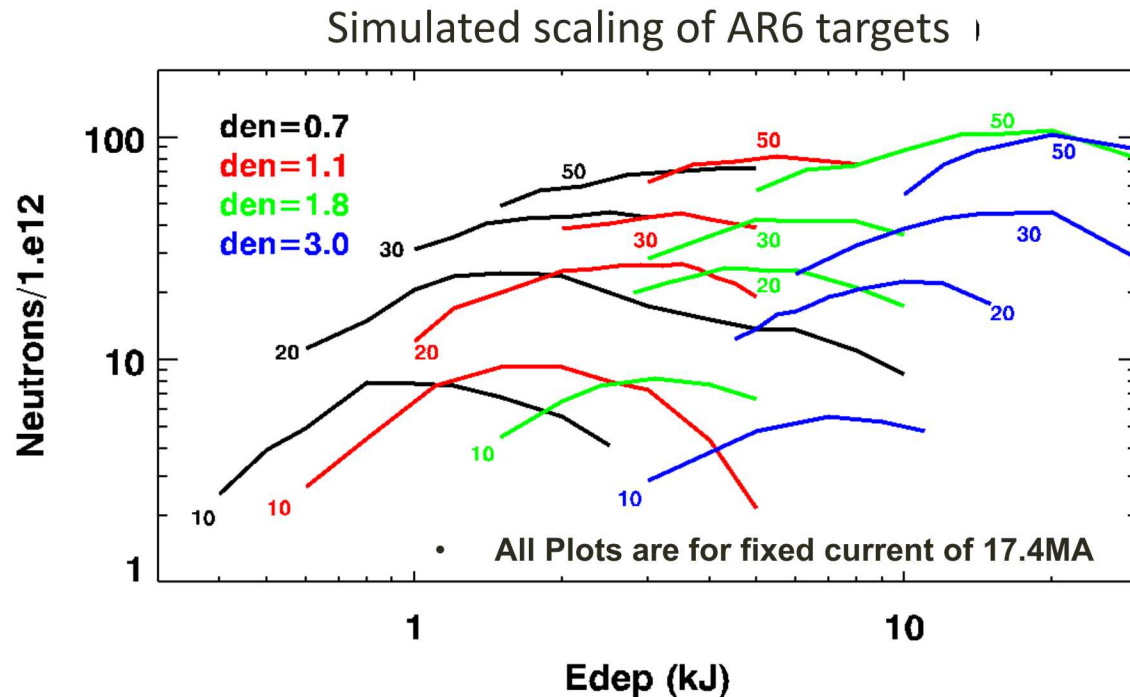

- Key MagLIF scaling issues can be studied without more drive current
- Larger fields increase the burn time
- Higher fuel densities lower convergence

# Performance optimized scaling is only achieved when field, fuel density, preheat energy, and current are all scaled simultaneously

只有在现场，燃料密度，预热能量和电流都同时缩放的情况下，才能实现性能优化的缩放比例

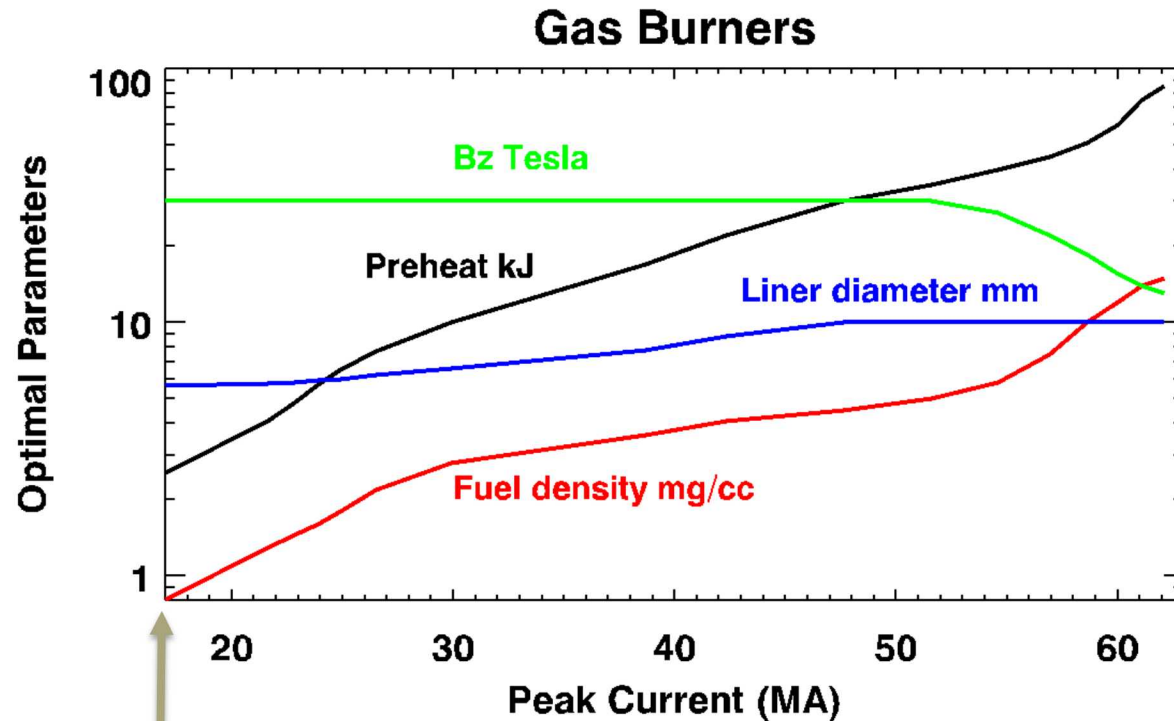

According to simulations, we have not yet been able to test optimal conditions yet on Z

# Thus far, experiments with increased drive current have not led to increases in performance

迄今为止，增加驱动电流的实验并未导致性能的提高

- 10-20% increase in peak current has been demonstrated with 10 T
- 19+ MA, 13-17T fields (non-uniform)
- Integrated tests thus far have not shown improvement in performance
  - **Increased convergence**

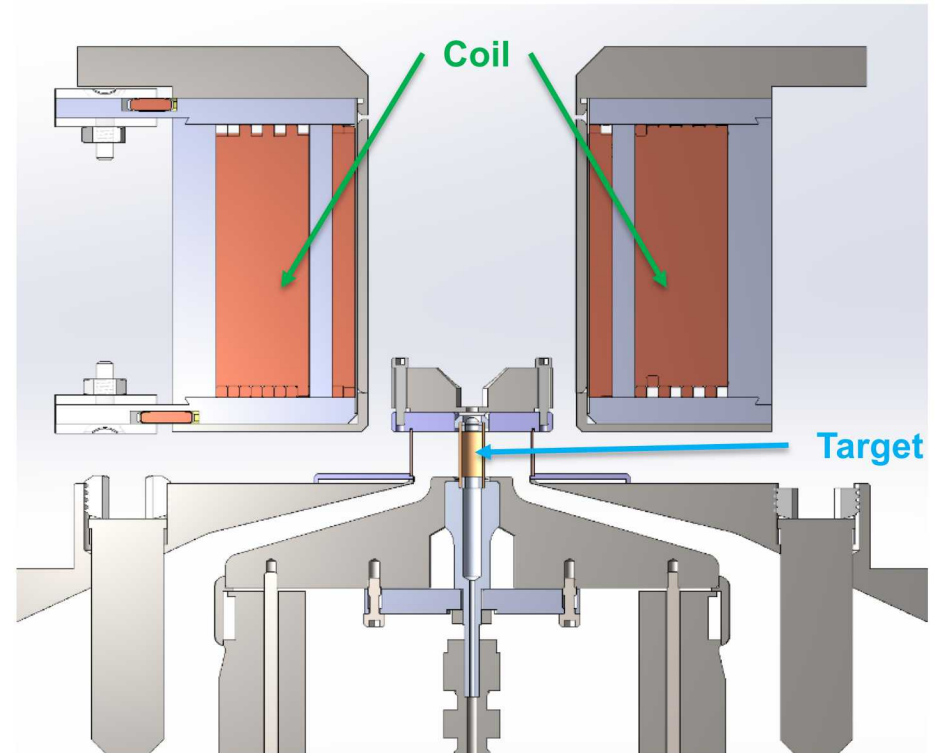
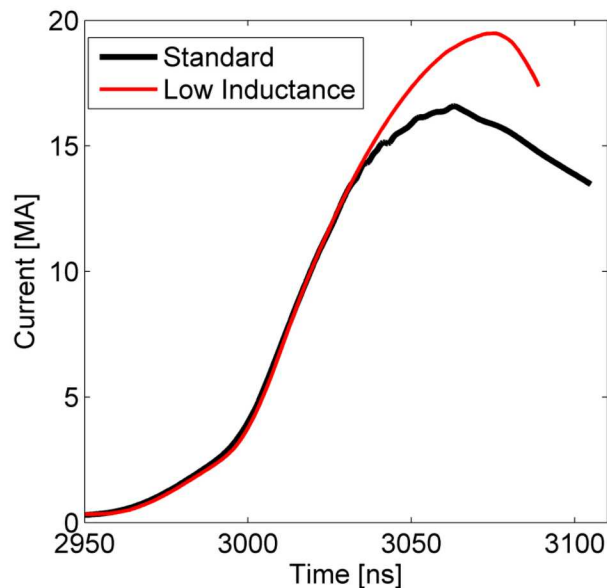

# Experiments with identical coil designs show expected performance trend with field strength

Stagnation Column

Tren

具有相同线圈设计的实验显示了预期的场强性能趋势

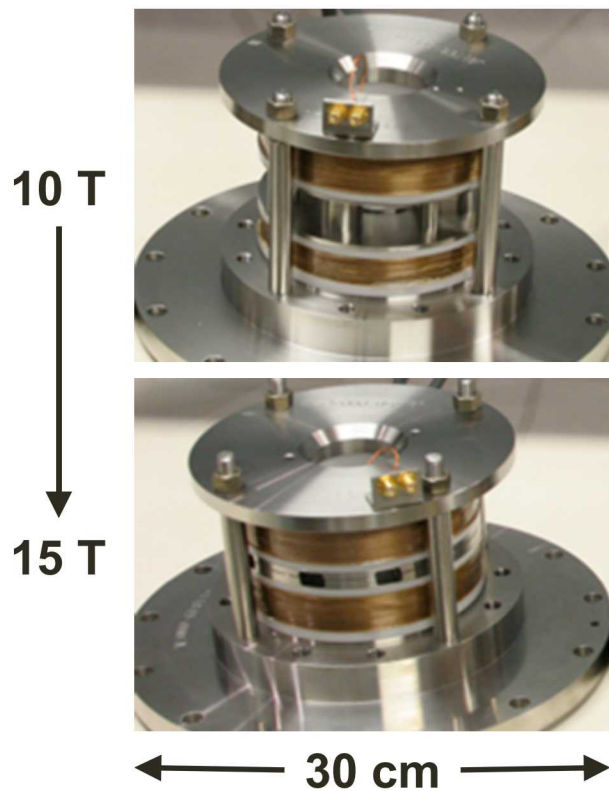

Standard coil, high inductance feed, 17MA peak current

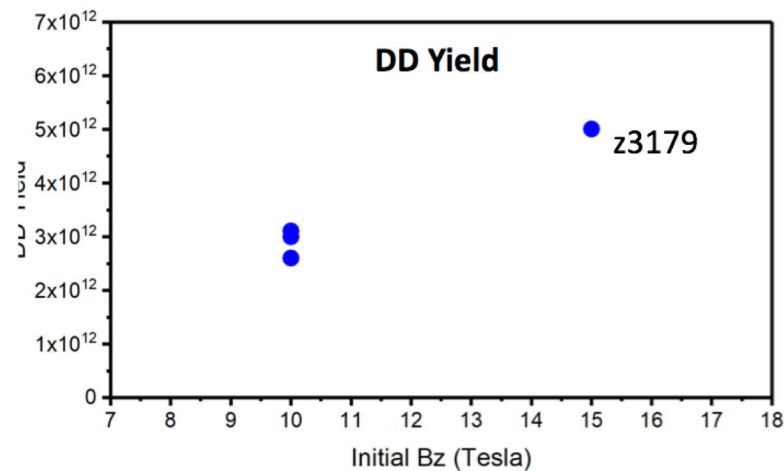
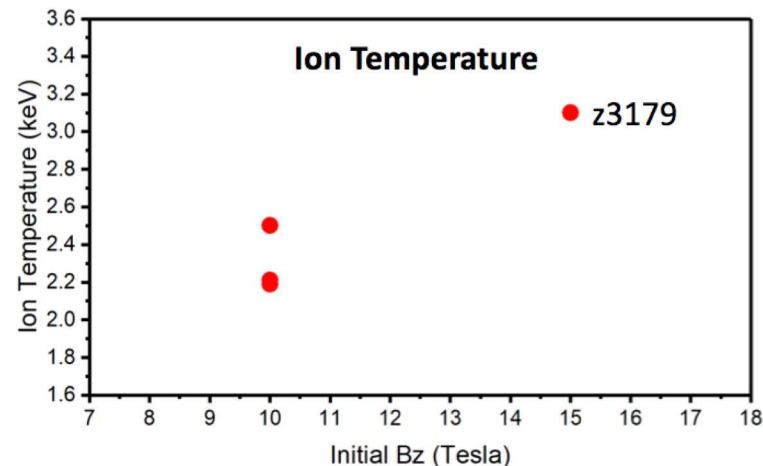
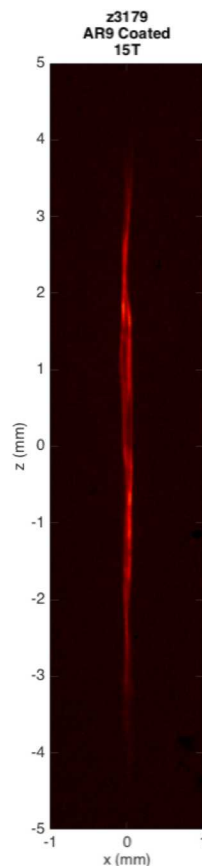

# Initial experiments testing scaled preheating at NIF have been promising

在NIF测试预热的初始实验一直很有前景

3.2 mg/cc cryogenic D2

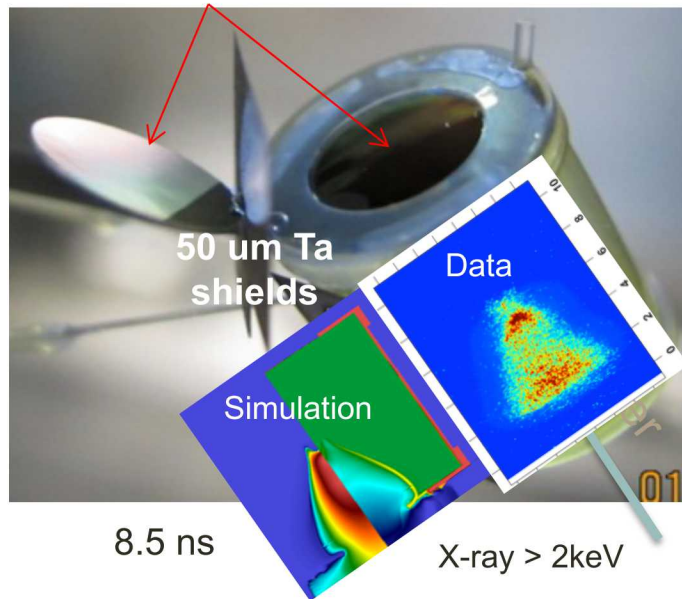

experiment

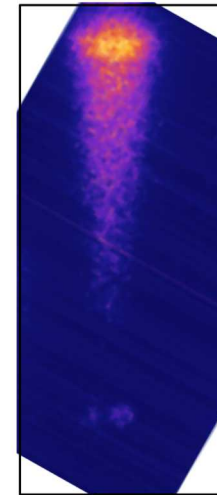

simulation

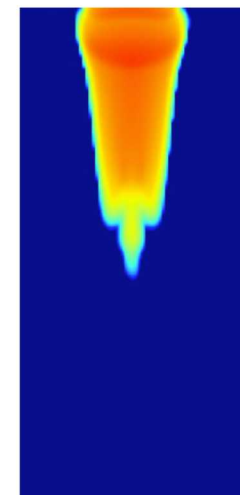

Time dependent laser propagation is in remarkable agreement with pre-shot simulation predictions

**Primary Objective: Assess whether or not laser preheating is a viable scaling path for magnetized target fusion (MagLIF)**

- Demonstrated 24 kJ absorption into warm hydrocarbon surrogate
- Demonstrated 16 kJ into 4.8 mg/cc D2
- Next steps: warm hydrocarbon with 30 Tesla, 22 kJ into D2, verify transport

# Sandia is also collaborating with LLE to develop a scaled MagLIF platform on OMEGA which strongly complements research done at Z

桑迪亚还与LLE合作在OMEGA上开发一个规模化MagLIF平台，该平台强化了Z

## Laser-driven MagLIF on OMEGA

- 10× smaller (test platform scaling)
- More data: 2 shot days on OMEGA returns more data than a years worth of shots on Z
- Access to diagnostics with greater dynamic range
- Ability to probe magnetic field with proton radiography (impossible on Z)

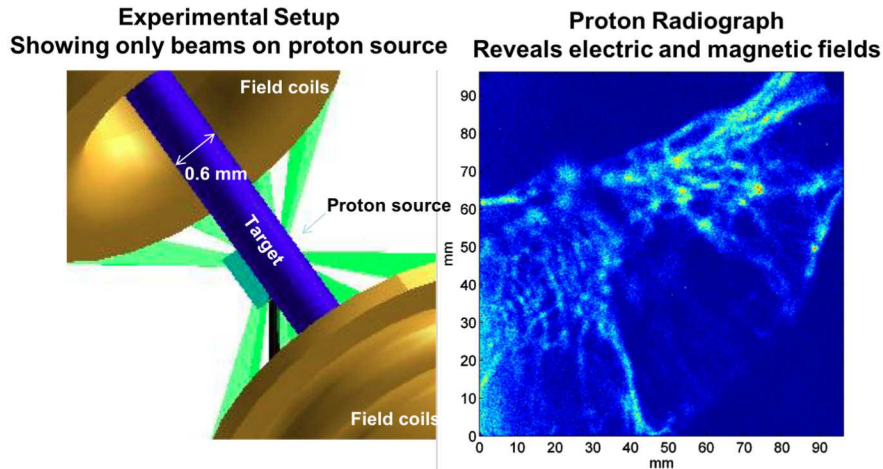
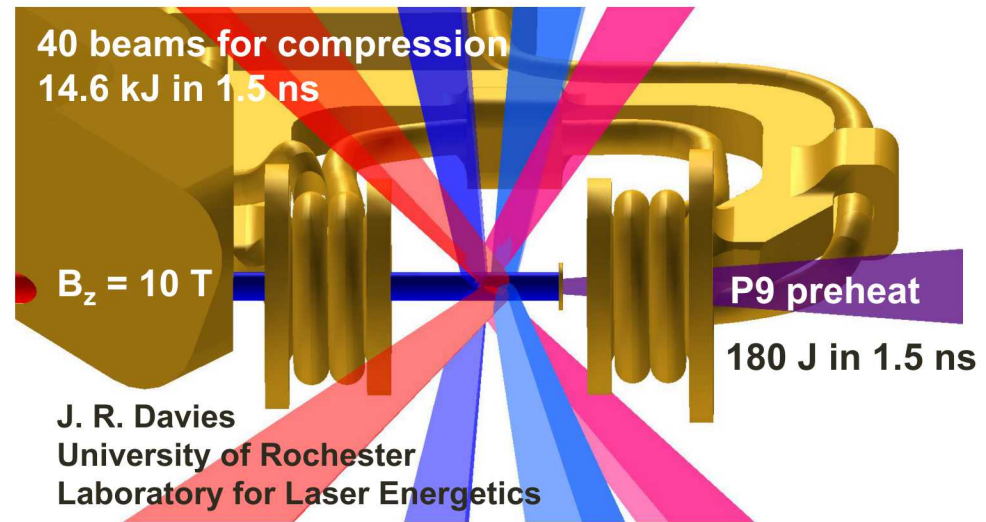

14 MeV protons generated by D-<sup>3</sup>He fusion are used to probe the electric and magnetic fields in the compressed, magnetized target on Omega

# Summary

## 概要

- The performance of MagLIF targets has improved to produce  $1.1e13$  neutrons from deuterium fuel
  - Improvements to laser heating
  - Improved liner stability with higher velocity
  - Higher fuel density with less convergence
- We are working to develop platforms capable of delivering more drive current, higher initial magnetic fields, and more preheat energy simultaneously to test performance scaling on Z
- A significant effort is underway to understand sources of mix and impact on performance
- Significant variability in performance is observed in some of our experiments, we are working to understand this
- We are evaluating ignition scale laser energy coupling (30kJ) at NIF
- 由于错误翻译, 我对任何混淆抱歉

# Backups

# In order to test scaling on Z, we are working on a couple of different approaches to increase the initial B-field

为了测试Z的缩放比例，我们正在研究几种不同的方法来增加初始B场

New low inductance coil, operation up to 25 T



Coil design courtesy of Derek Lamppa

Slotted helical liners "Automag"

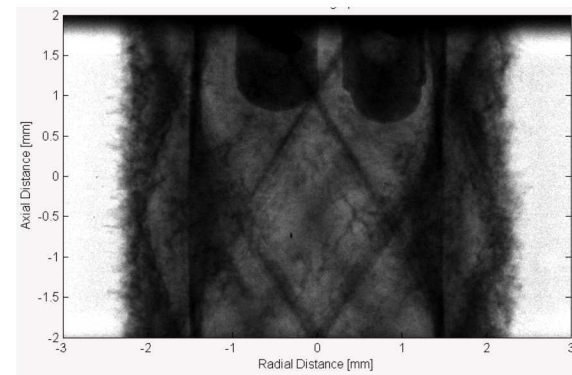
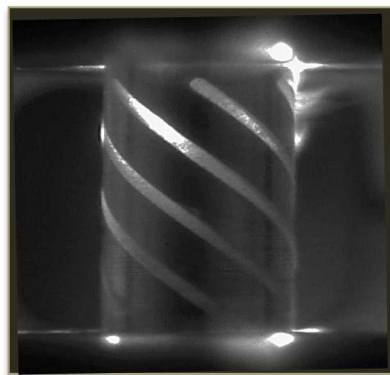
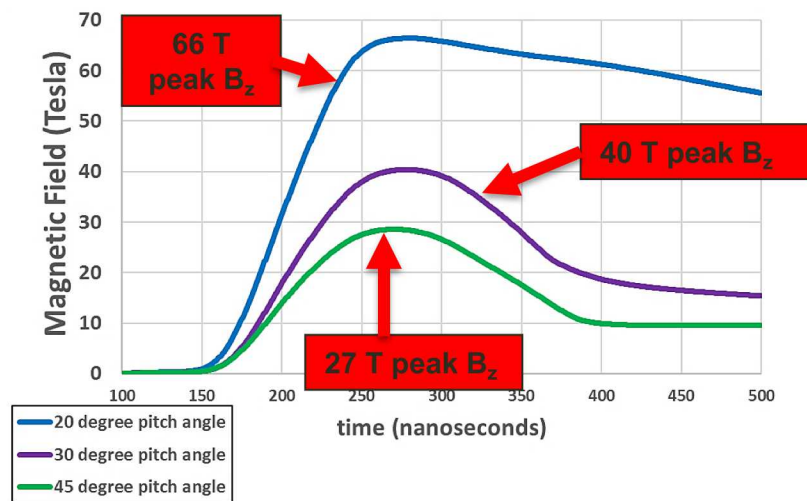

# We are developing two different approaches in order to deposit >2kJ of laser energy in the fuel

我们正在开发两种不同的方法，以便在燃料中沉积 > 2kJ 的激光能量

## Cryogenic Targets

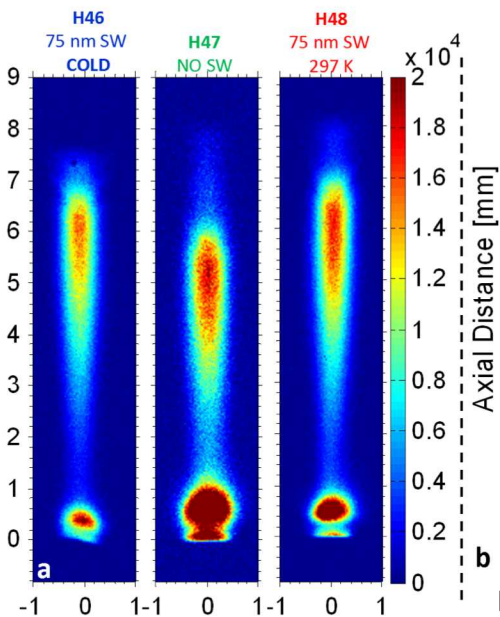
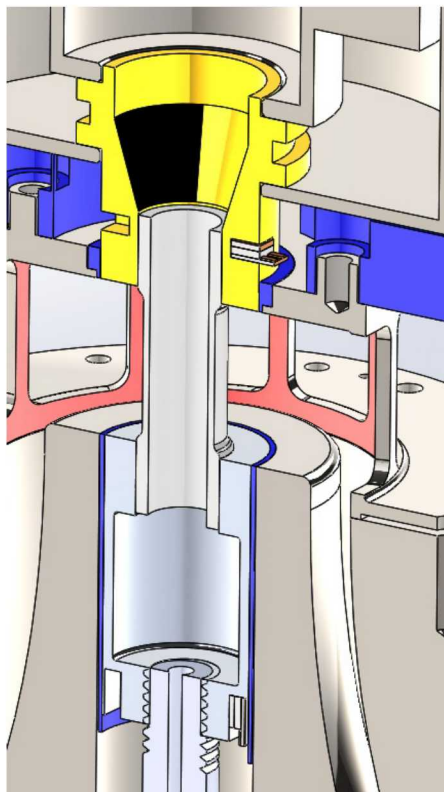

## Lasergate

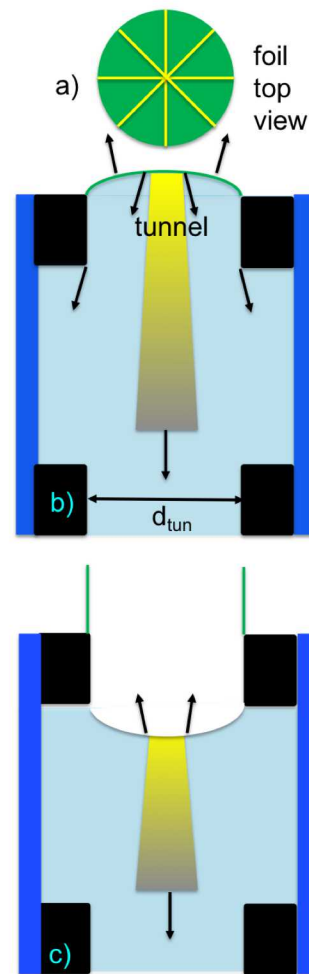

# With its long preheat stage, MagLIF is highly susceptible to fuel impurities (mix)

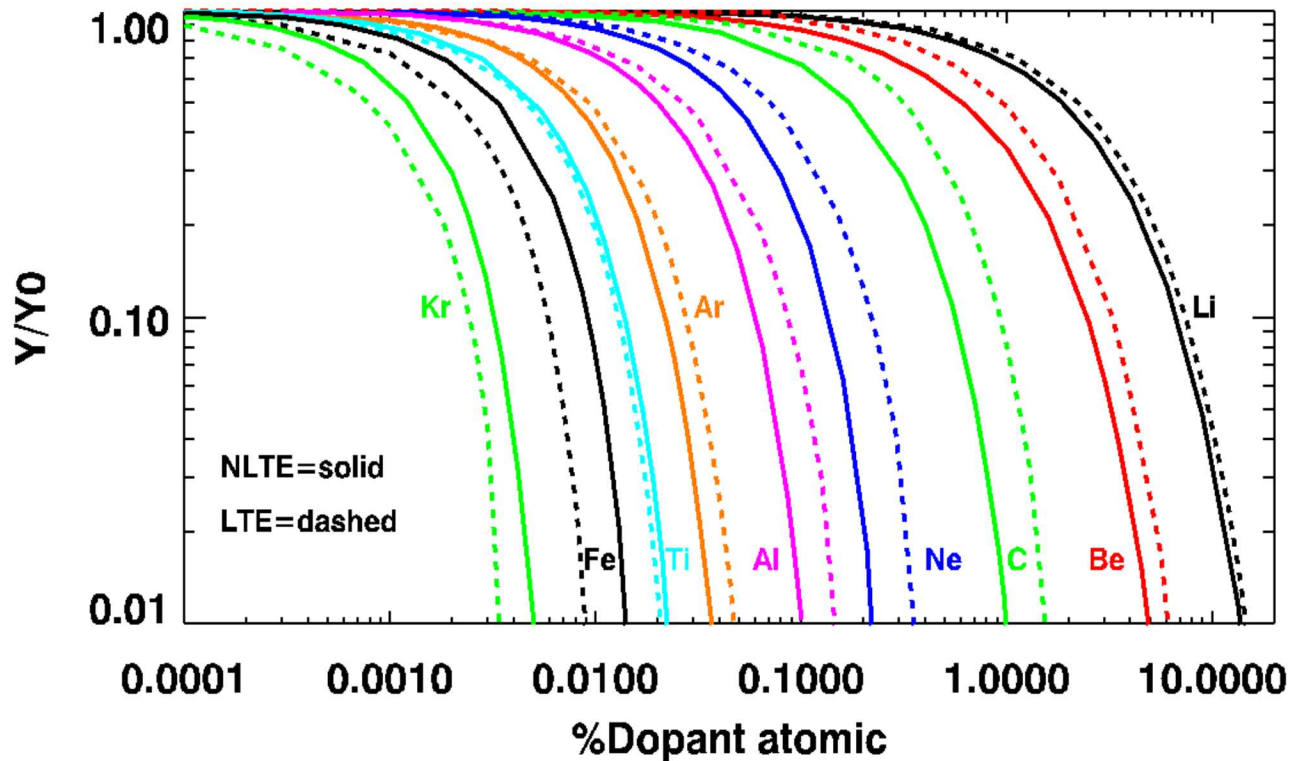

Even small high-Z fractions lead to catastrophic radiative losses during the ~50 ns preheat stage.

*Are we on a mix cliff?*

# Hard x-ray imaging shows contiguous hot-spot on high performing experiments

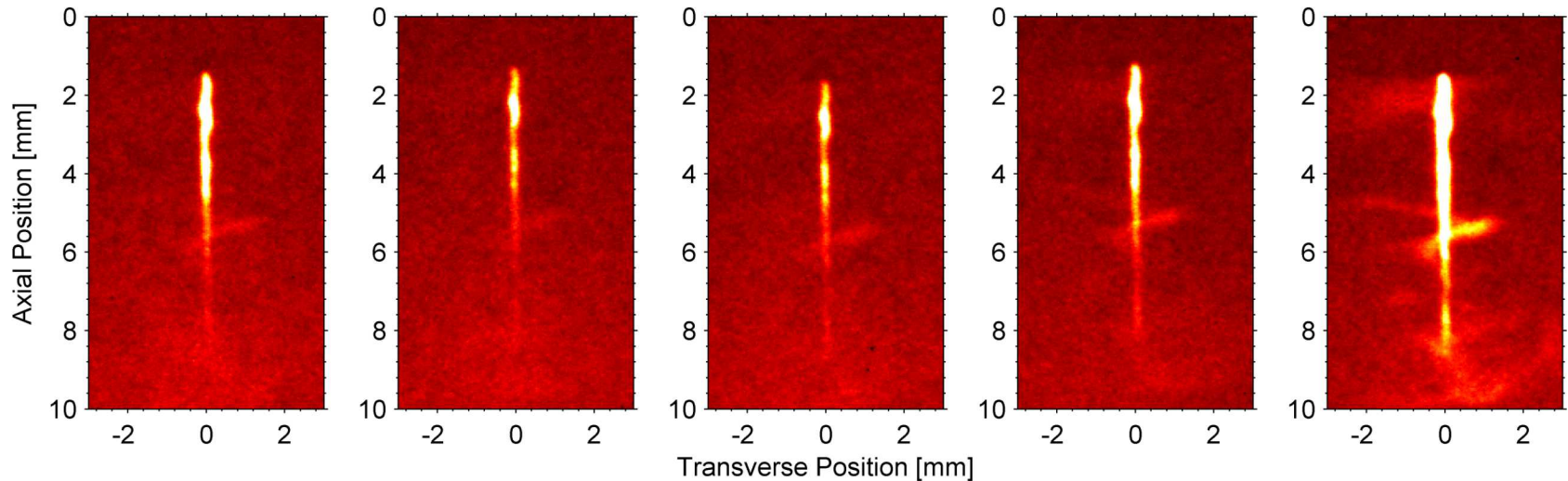

- Helical emission structure from the outside of the liner

# Spectroscopy is being used to infer the plasma temperature, density, and mix fractions

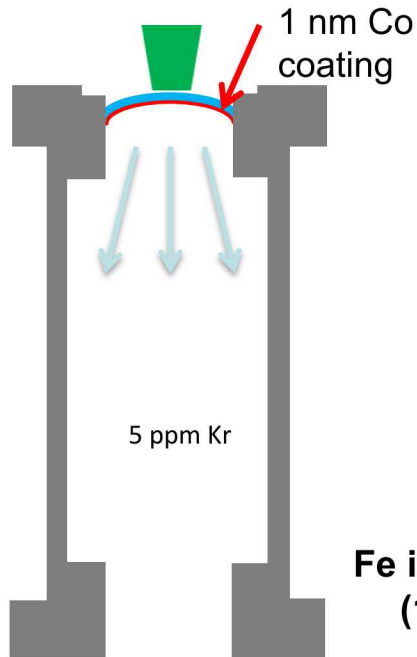

- Fe impurities from the Be liner/endcap mix into the stagnation column
- 5 ppm Kr dopant premixed into fuel
- Localized Co dopants

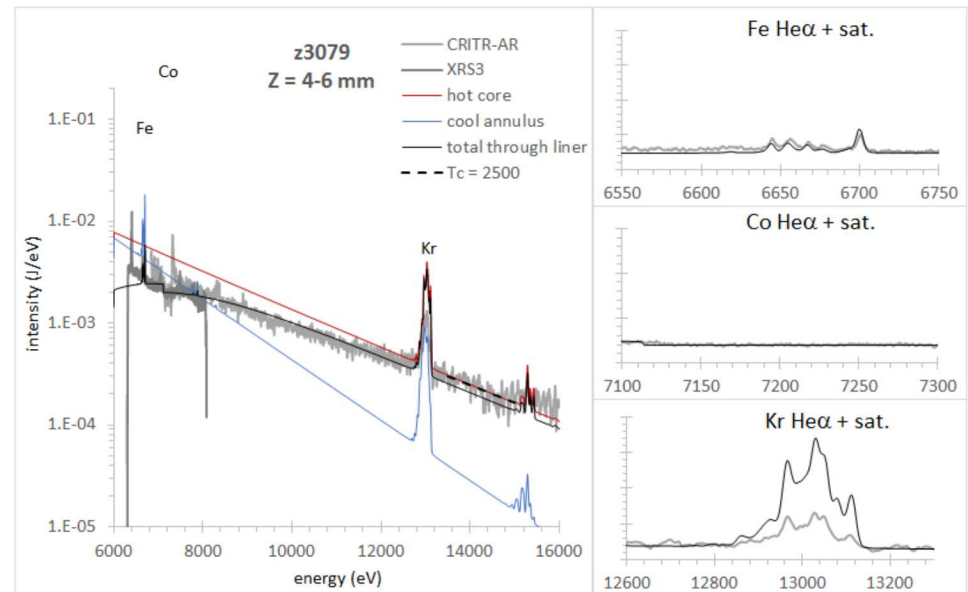
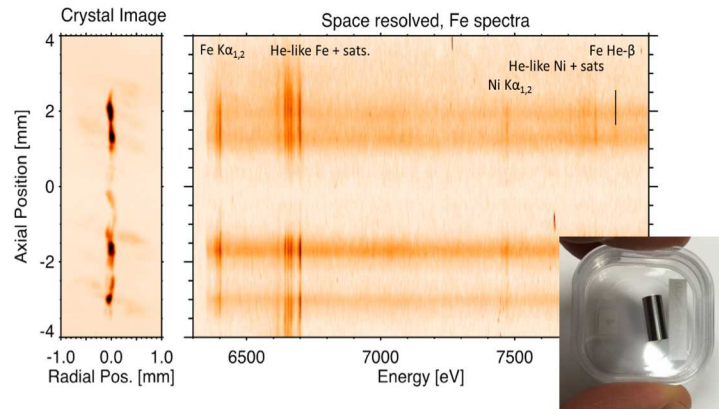

# Fe spectra and imaging data together form a physical picture in which there exists a hot core inside cold, compressed Be.

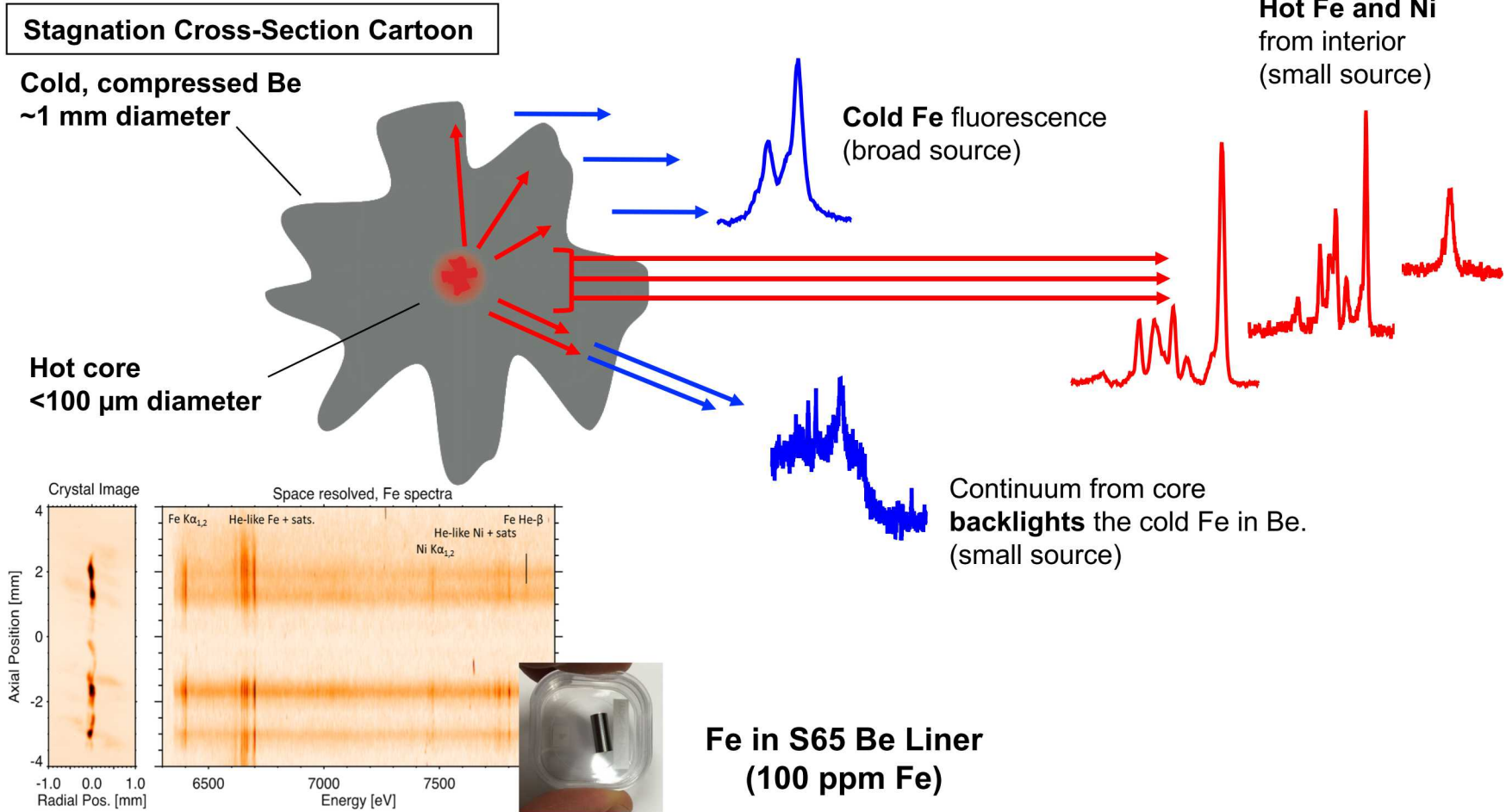

# Simulated primary neutron yields are highly sensitive to the coupled preheat energy

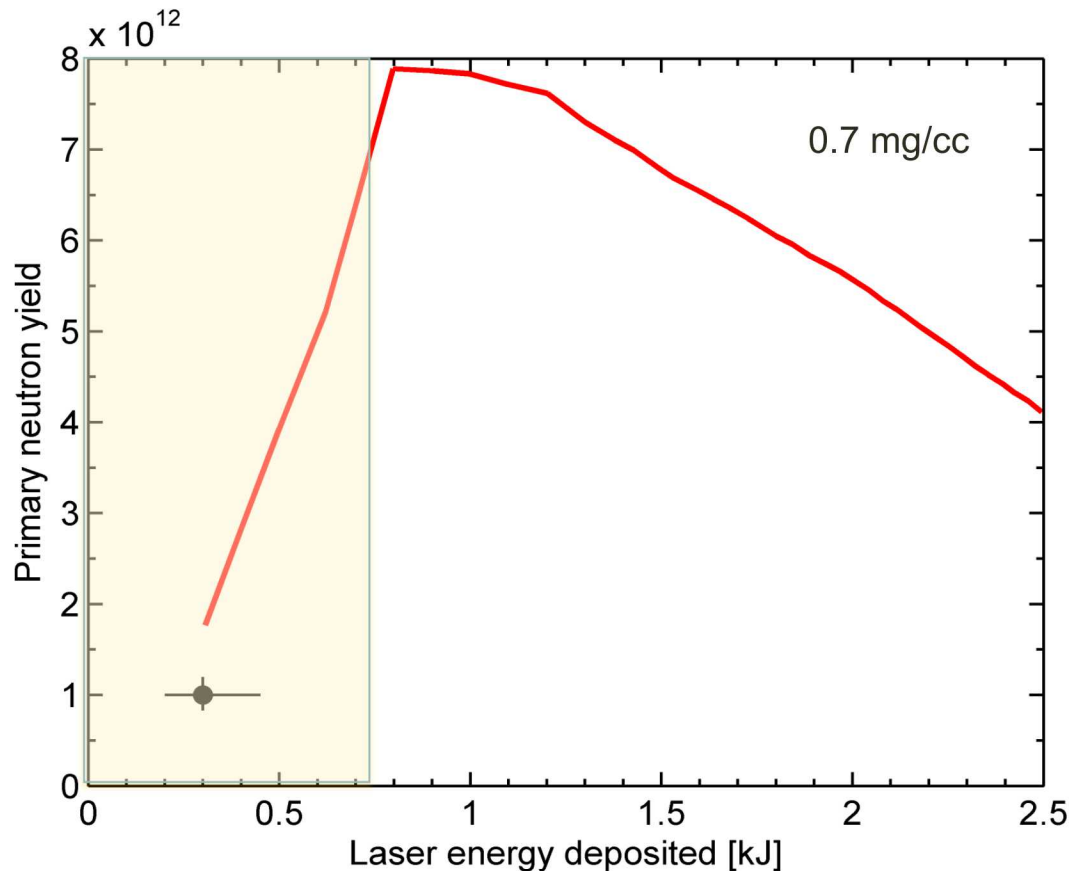

- With sufficient magnetization, yield is strong function of preheat energy

Assumes 10T, 17 MA, 2D clean implosion (No mix, 3D, etc)

# Simulated primary neutron yields are highly sensitive to the coupled preheat energy

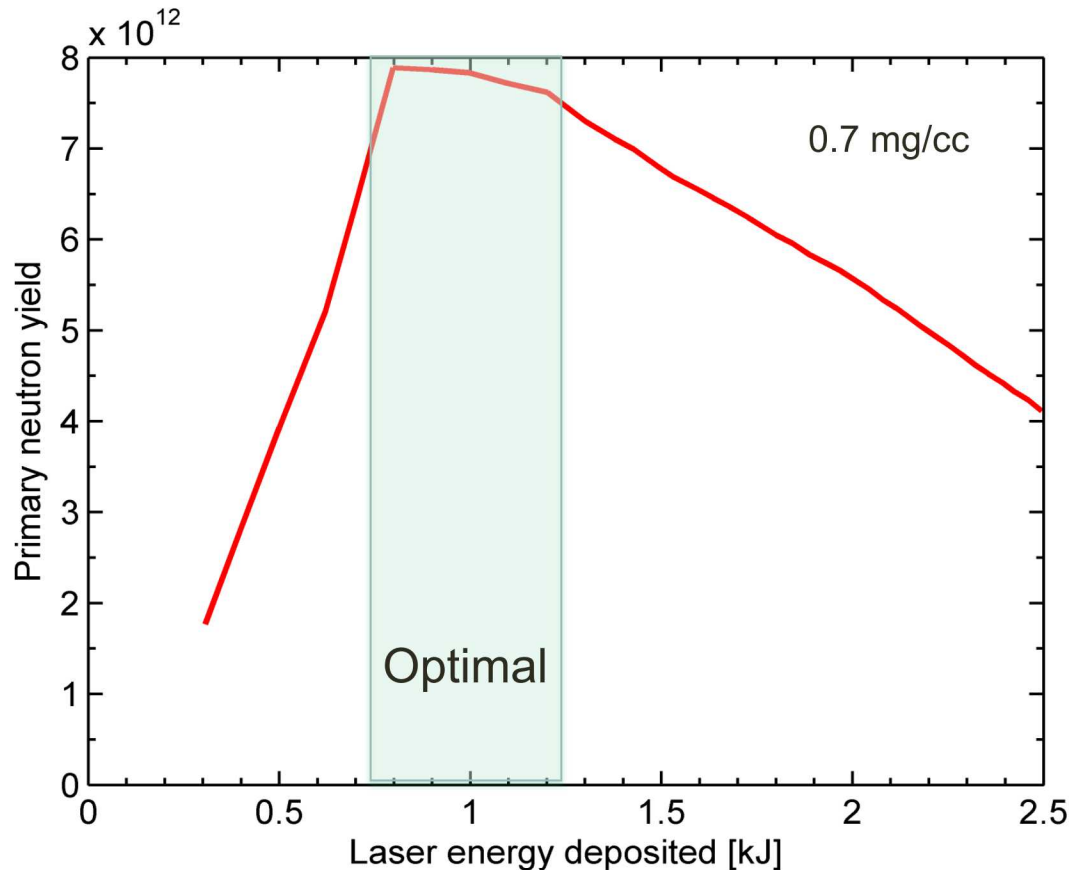

- With sufficient magnetization, yield is strong function of preheat energy
- Simulations predict maximum DD yields of  $6-8 \times 10^{12}$  (clean) with a coupled energy of  $\sim 1$  kJ

Assumes 10T, 17 MA, 2D clean implosion (No mix, 3D, etc)

# Simulated primary neutron yields are highly sensitive to the coupled preheat energy

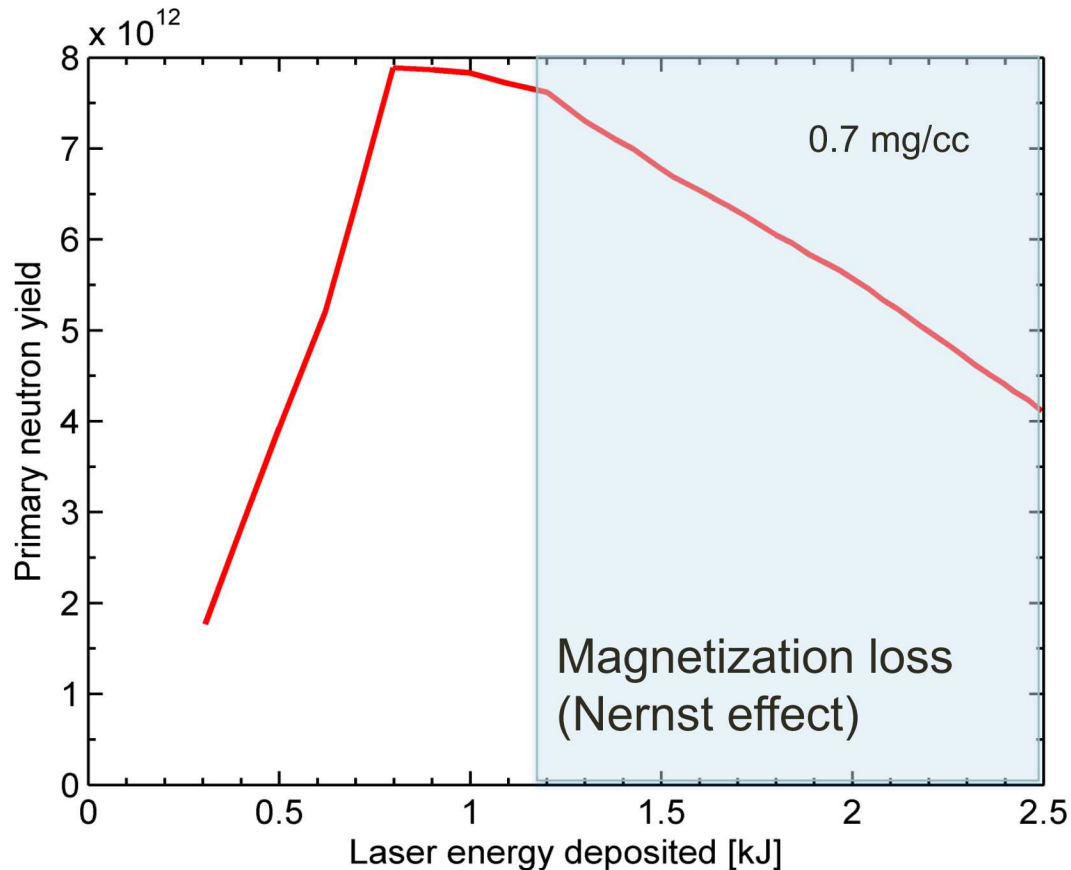

- With sufficient magnetization, yield is strong function of preheat energy
- Simulations predict maximum DD yields of  $6-8 \times 10^{12}$  (clean) with a coupled energy of  $\sim 1$  kJ
- Larger coupled energies reduce yield due to Nernst effect

Assumes 10T, 17 MA, 2D clean implosion (No mix, 3D, etc)

First MagLIF experiment

S

X-ray imaging

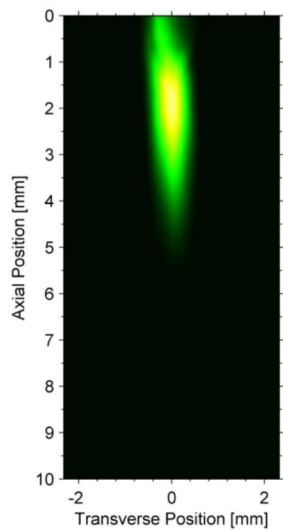

LEH window transmission

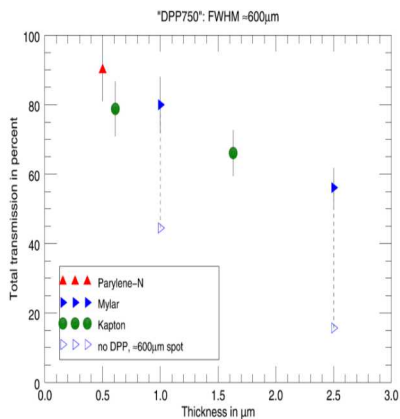

Distributed phase plates

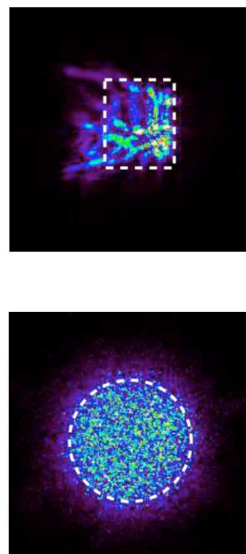

SBS backscatter

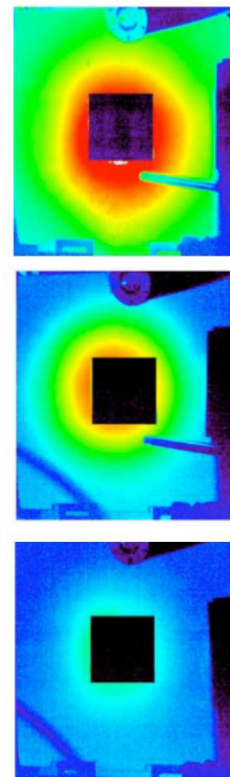

Multi-frame Shadowgraphy

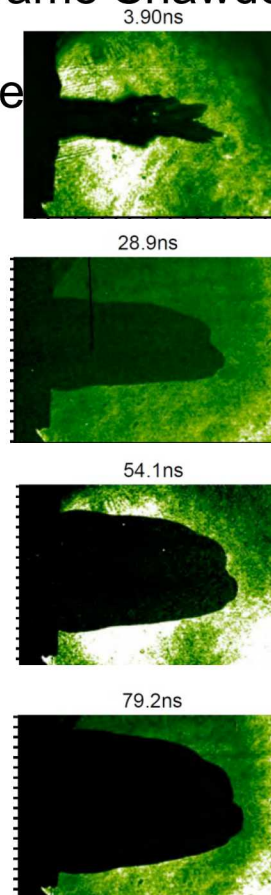

FY14

FY15

FY16

FY17

FY18

# In order to improve preheat energy coupling and understanding, laser heated gas cell experiments in the PECOS chamber have been performed

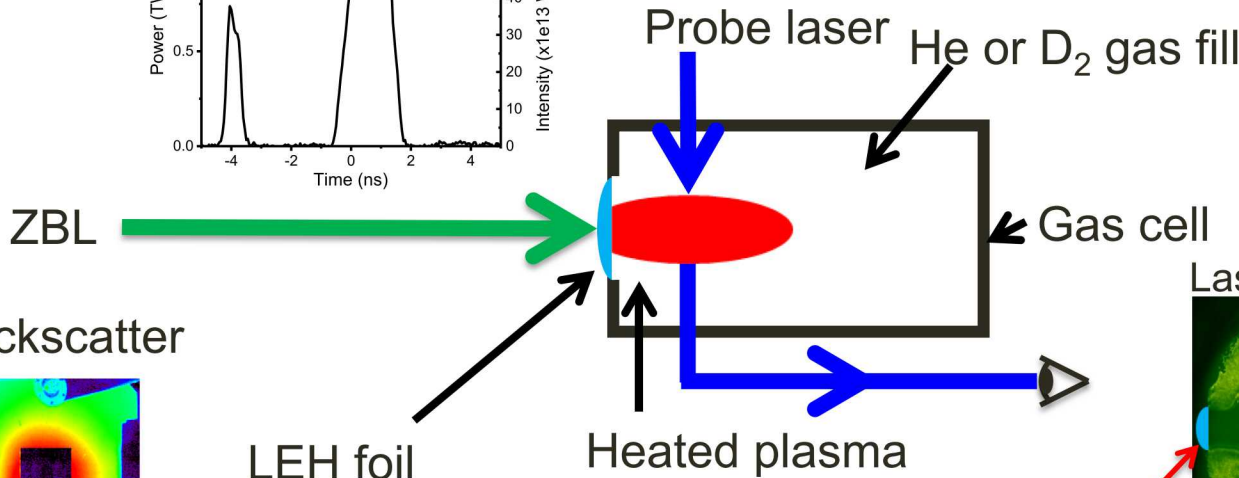
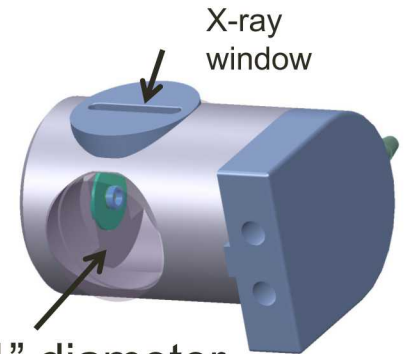
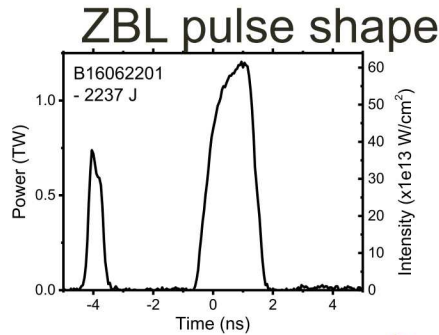
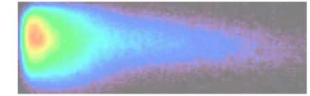

Backscatter

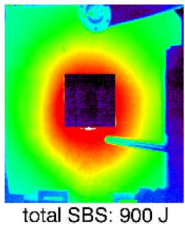

LEH foil  
(1.5  $\mu$ m  
polyimide)

Laser shadowgram

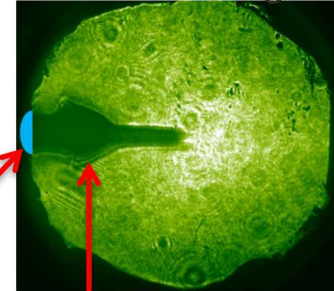

LEH foil  
Heated plasma

# First ever tritium experiment was conducted on Z in August 2016

- **Motivation:** We need to develop experience with tritium and it can benefit our scientific understanding through higher yields (50 -100x) and higher energy spectrum neutrons (14 MeV)
- **Approach:** We safely conducted a tritium experiment on Z using a trace amount of tritium (0.1% T), applied engineering controls (e.g. containment) and thorough planning
- **Outcome:** Neutron diagnostics measured a primary DT neutron signal for the first time on Z and tritium was not detected above background levels using surface and airborne monitoring techniques

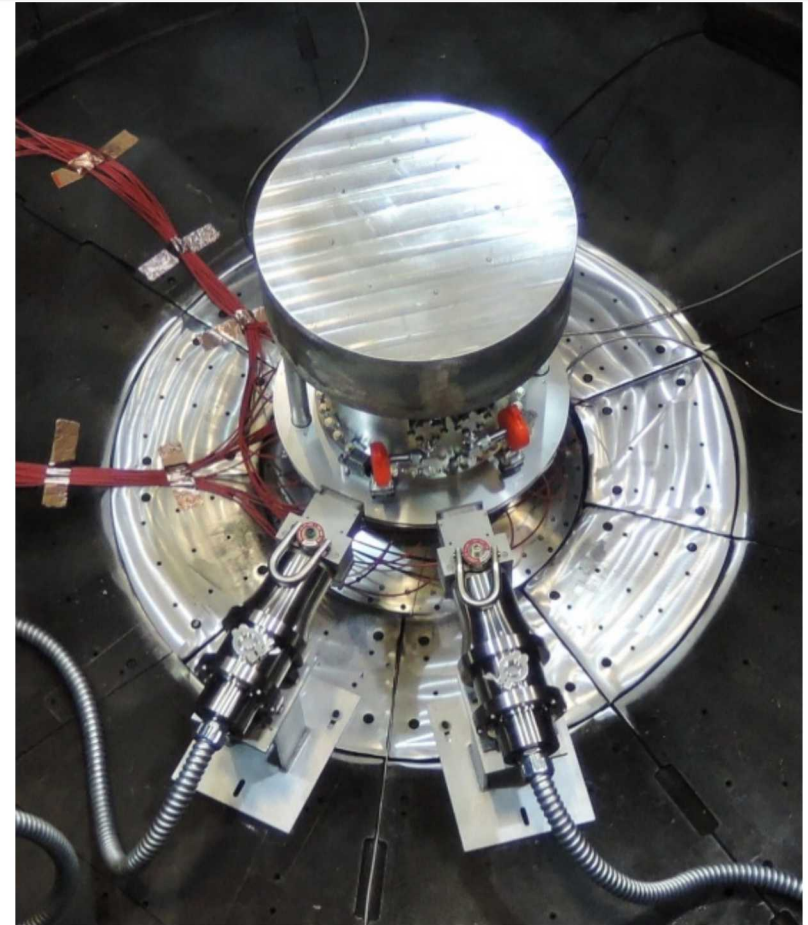

Experimental configuration for first ever tritium experiment on Z

The observables are well modeled by 2-D and 3-D simulations if we assume  $\sim 200$  J of laser energy coupled\* to the target

Imaging

Radiography

Comparison to z2591 Observables

Data

Sim

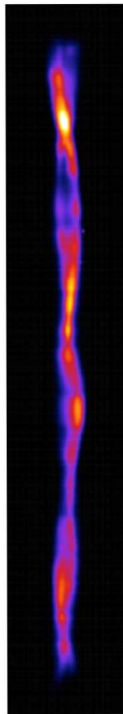
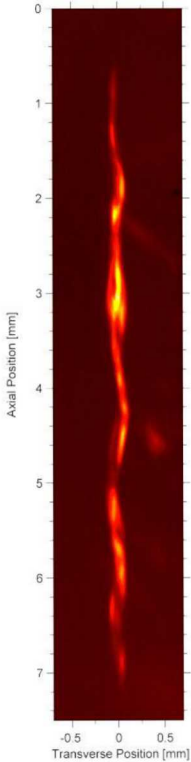

Z2613

A. Sefkow simulations

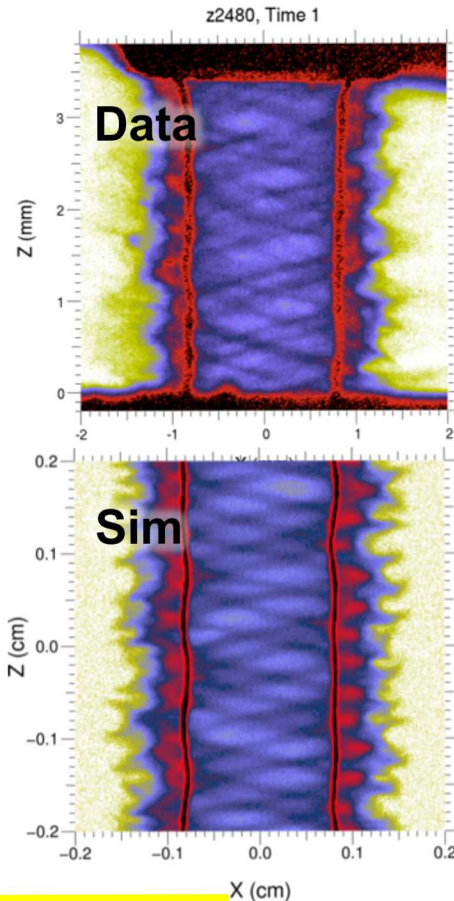

Parameter	Measured/inferred	Post-shot simulations
$r_{\text{stag}}^{\text{hot}}$	$44 \pm 13 \mu\text{m}$	$40 \mu\text{m}$
$\langle T_i \rangle^{\text{DD}}$	$2.5 \pm 0.75 \text{ keV}$	$3.0 \pm 0.5 \text{ keV}$
$\langle T_e^{\text{spec}} \rangle$	$3.0 \pm 0.5 \text{ keV}$	$2.7 \pm 0.5 \text{ keV}$
$\rho_{\text{gas}}^{\text{stag}}$	$0.3 \pm 0.2 \text{ g cm}^{-3}$	$0.4 \pm 0.2 \text{ g cm}^{-3}$
$\rho R_{\text{gas}}$	$2 \pm 1 \text{ mg cm}^{-2}$	$2.6 \pm 1.0 \text{ mg cm}^{-2}$
$\rho R_{\text{liner}}^{\text{stag}}$	$900 \pm 300 \text{ mg cm}^{-2}$	$900 \text{ mg cm}^{-2}$
$\langle p^{\text{stag}} \rangle$	$1.0 \pm 0.5 \text{ Gbar}$	$1.5 \pm 0.3 \text{ Gbar}$
$E_{\text{gas}}^{\text{stag}}$	$4 \pm 2 \text{ kJ}$	$7 \pm 2 \text{ kJ}$
$\langle B_z^f r_{\text{stag}} \rangle$	$(4.5 \pm 0.5) \text{e}5 \text{ G cm}$	$4.8 \text{e}5 \text{ G cm}$
$Y_n^{\text{DD}}$	$(2.0 \pm 0.5) \text{e}12$	$(2.5 \pm 0.5) \text{e}12$
$Y_n^{\text{DD}}/Y_n^{\text{DT}}$	$40 \pm 20$	$41-57$
$t_{\text{burn}}^{\text{FWHM}}$	$1.5 \pm 0.1 \text{ ns (x-ray)}$	$1.6 \pm 0.2 \text{ ns}$

Delivered laser energy is 2.5 kJ

\*Thick window (3.5 micron experiments)

# The observables are also well modeled by 3-D simulations if we assume ~500 J of laser energy coupled\* to the target

## Imaging

## Radiography

## Comparison to z2613 Image

Data

Sim

Data

Sim

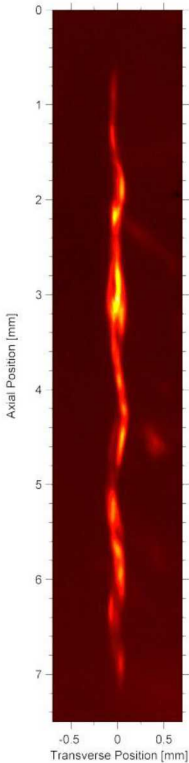

Z2613

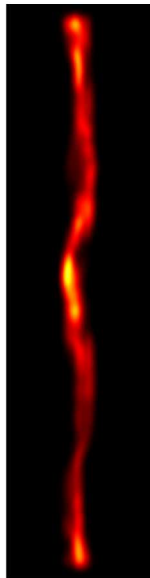

C. Jennings simulations

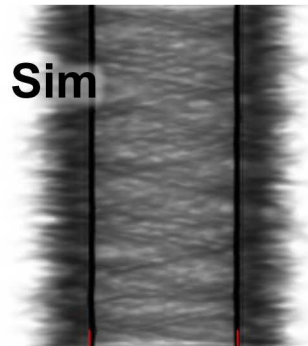
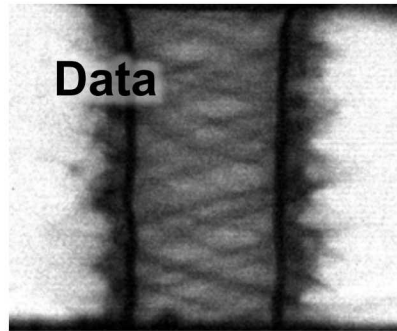

Parameter	Measured/inferred	Post-shot simulations
-----------	-------------------	-----------------------

- FWHM  $91 \pm 40$  mm  $121 \pm 40$  mm

### Sim. Values:

- Burn weighted, time integrated ion temp: **3.5 keV**
- Continuum emissivity (~9keV) weighted, time integrated electron temperature: **3.3 keV**
- Iron contaminant in Be emissivity weighted, time integrated electron temperature: **1.8 keV**
- Continuum emissivity (~9keV) weighted, time integrated fuel density:  **$0.33 \text{ g cm}^{-3}$**
- DD Yield:  **$4.e12$**
- FWHM neutron pulse: **1.7ns**
- Liner  $\rho R$  integrated along a single azimuth and axially averaged. Increases from  **$520 \pm 60 \text{ mg cm}^{-2}$**  to  **$980 \pm 110 \text{ mg cm}^{-2}$**  over the FWHM of the neutron pulse.

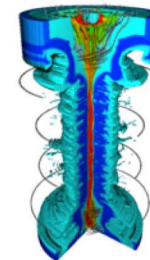

# Bayesian inference tools are now being applied to better quantify stagnation performance ( $P\tau$ , BR) and identify important correlations

Hotspot Parameters

$$\{T_i\} = \{T_e\}$$

$$\{\tau_\nu^\ell\}$$

$$\{P_{HS}\}$$

$$\{f_{mix}\}$$

$$\{Z_{mix}\}$$

$$\{R_{HS}\}$$

$$\overline{BR}$$

$$\tau_{burn}$$

$$\delta h$$

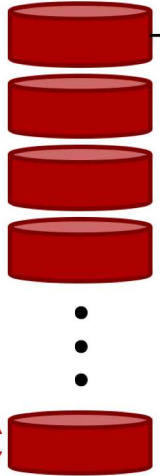

**X-ray Emission:**

$$Y_\nu = A_{f-f} \sum_{n=1}^N e^{-\tau_\nu^\ell} \tau_{burn} 2VP_{HS}^2 \int_0^1 \tilde{r} d\tilde{r} \frac{g_{FF}(Z)}{(1 + \langle Z \rangle)^2} \sum_i f_i \tilde{j}_i \frac{e^{-h\nu/T}}{T^{3/2}}$$

$$\tilde{j}_i \equiv \frac{j_i}{j_D} = Z_i^2 + \frac{A_{f-b} Z_i^4}{A_{f-f} T} e^{Ry Z_i^2 / T}$$

**Neutron Emission:**

$$\frac{dN_{DD}}{dE} = \sum_{n=1}^N \frac{P_{HS}^2 V \tau_{burn}}{(1 + \sum_i f_i Z_i)^2} \int_0^1 \tilde{r} d\tilde{r} \frac{(\sigma v)_{DD}}{T_i^2} I_o(E)$$

$$*I_o(E) = e^{-\frac{2E}{\sigma^2} (\sqrt{E} - \sqrt{E})^2}$$

$$Y_{DD} = 3.2 \times 10^{12} \pm 20\%$$

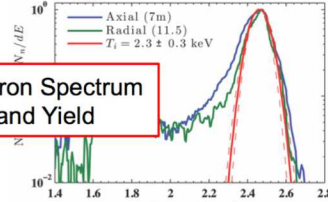

Neutron Spectrum and Yield

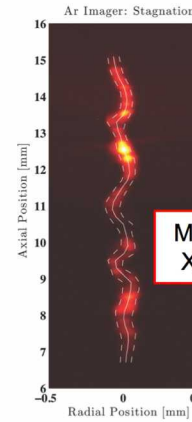

Monochromatic X-ray Imaging

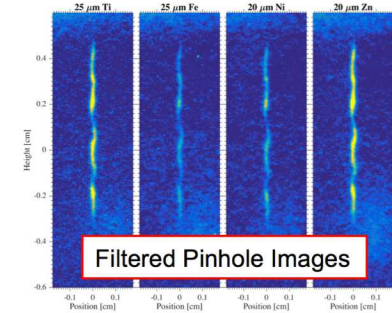

Filtered Pinhole Images

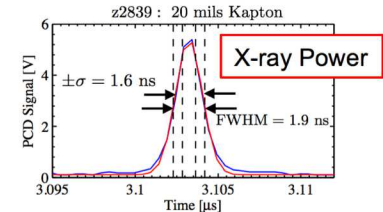

X-ray Power

$$Y_\gamma = 10 \text{ J} \pm 20\%$$

Prior

Data

Posterior

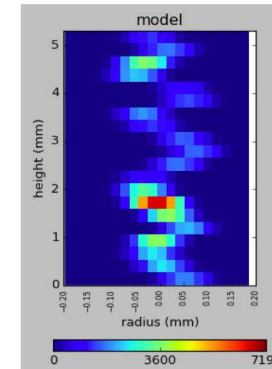
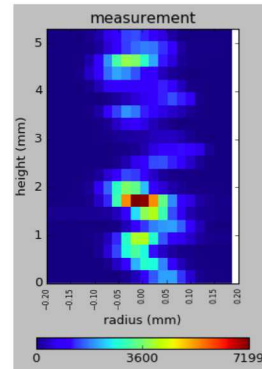
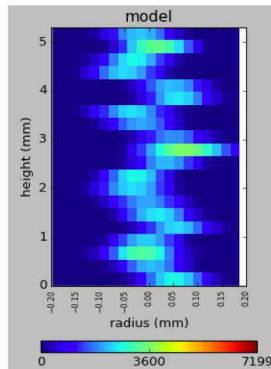

Spherical Crystal Imager Example

# Performance can also be improved with with increased load current, but the convergence ratio goes up

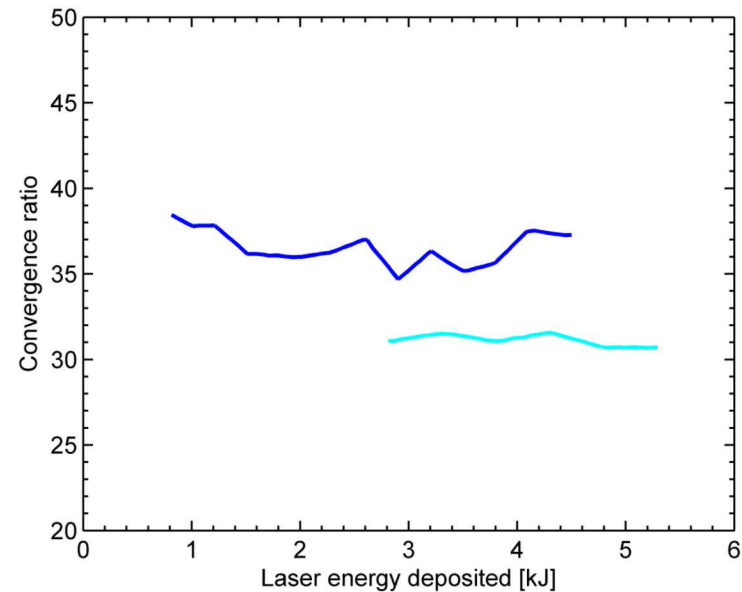
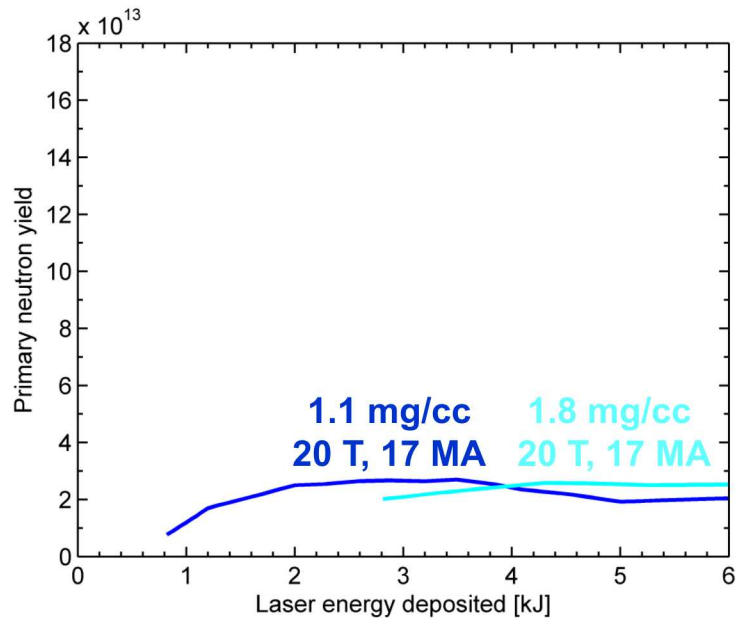

# Performance can also be improved with with increased load current, but the convergence ratio goes up

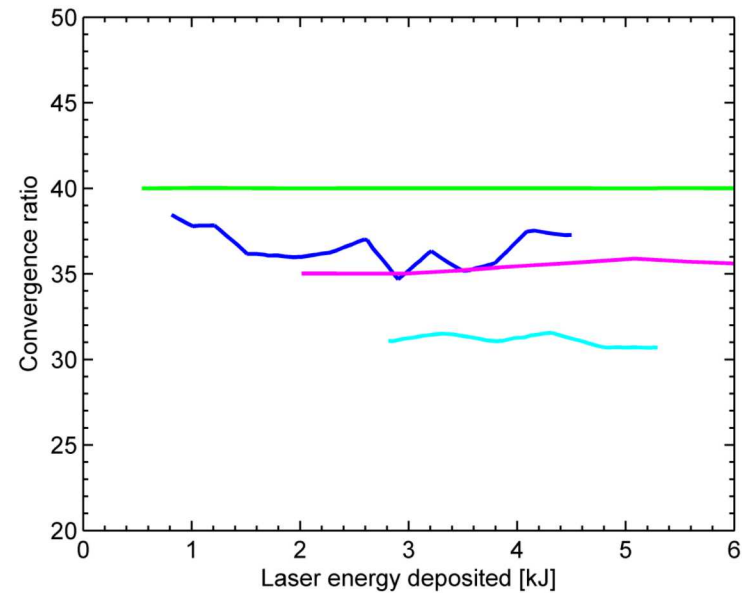
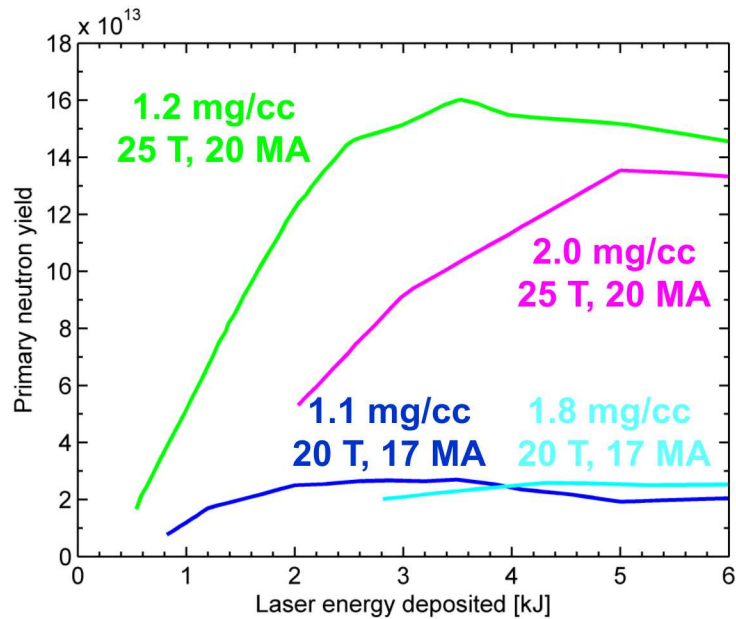

# 2D MHD simulations of our standard MagLIF configuration match experiments to within 2-3x

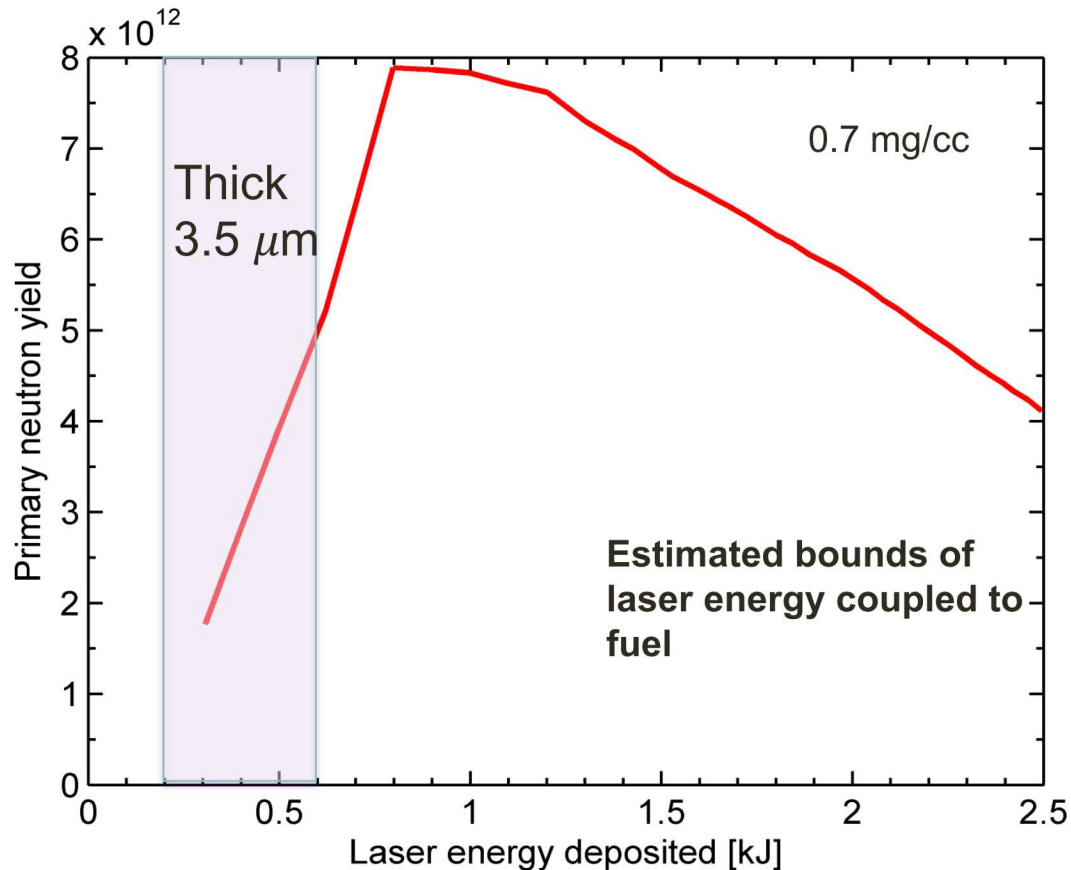

- 200-600J estimated coupled with thick (3.5  $\mu\text{m}$ ) windows

Assumes 10T, 17 MA, clean implosion (No mix, 3D, etc)

# 2D MHD simulations of our standard MagLIF configuration match experiments to within 2-3x

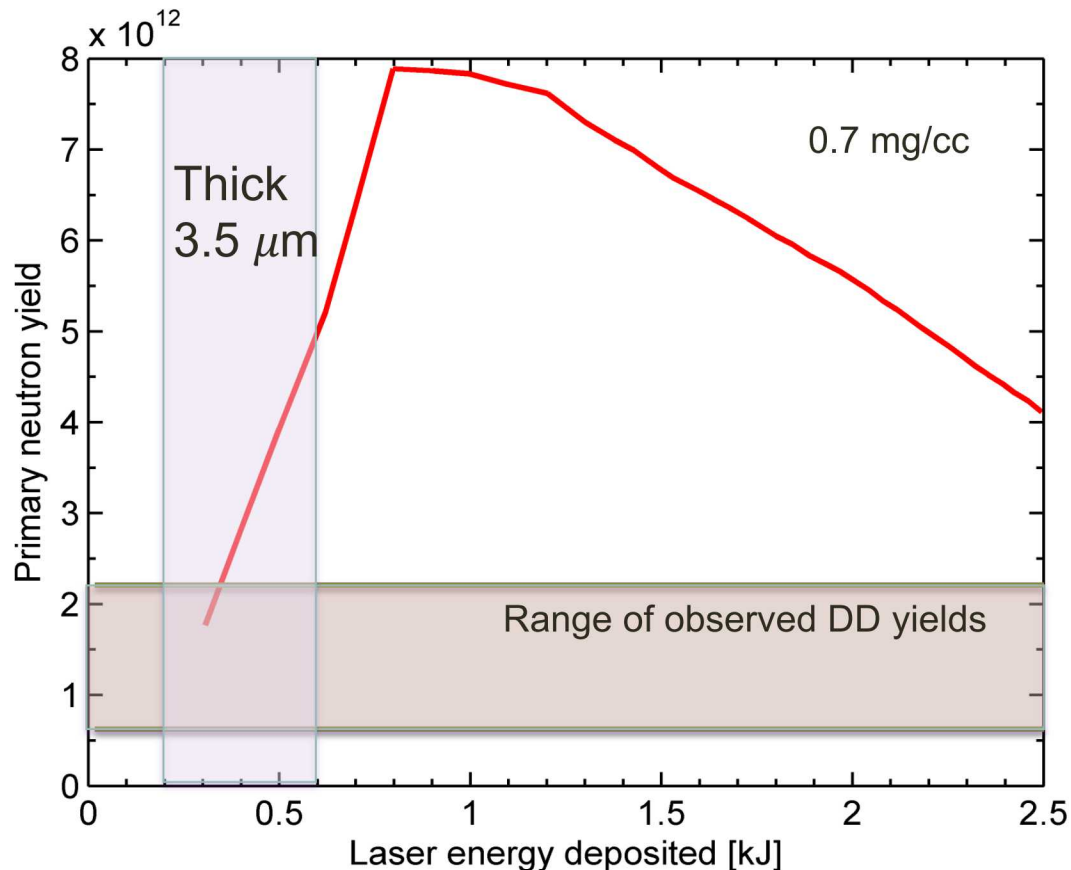

- 200-600J estimated coupled with thick (3.5  $\mu\text{m}$ ) windows
  - Initial experiments produced up to  $2 \times 10^{12}$  primary DD neutrons

Assumes 10T, 17 MA, clean implosion (No mix, 3D, etc)

# 2D MHD simulations of our standard MagLIF configuration match experiments to within 2-3x

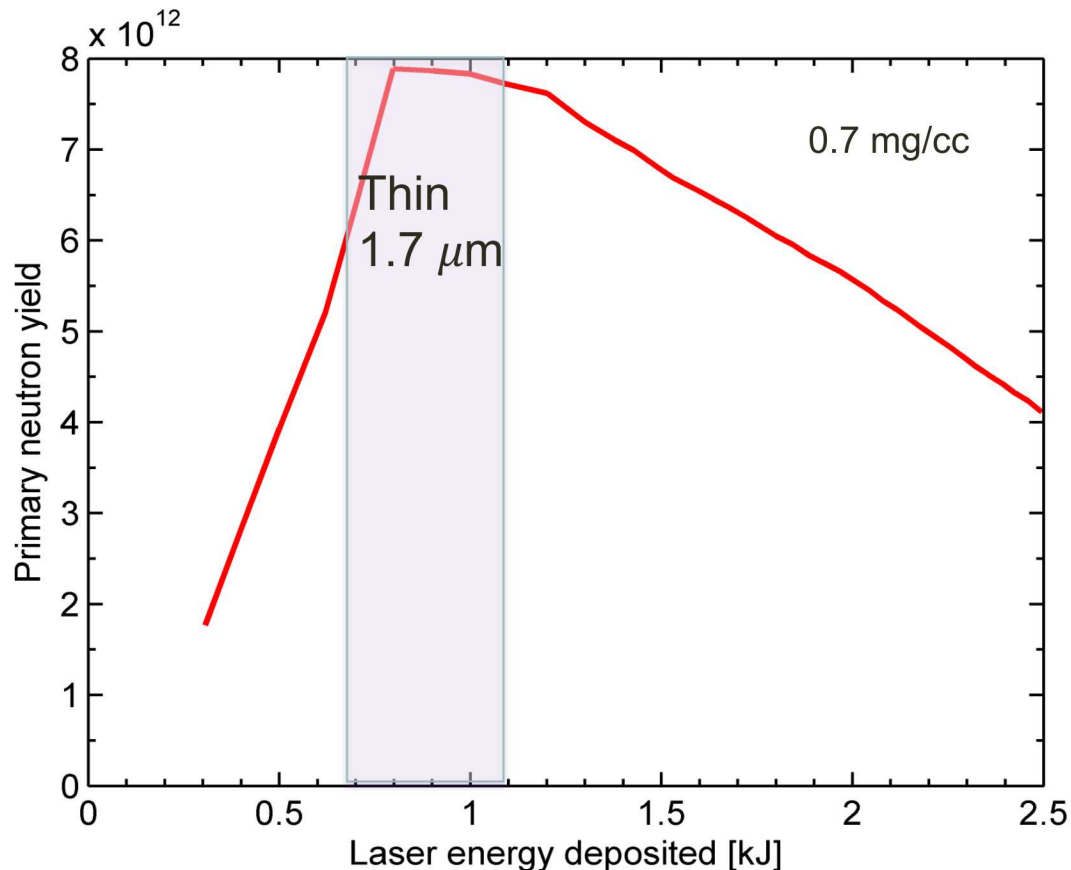

- 200-600J estimated coupled with thick (3.5  $\mu\text{m}$ ) windows
- 600-1200J estimated for thin windows (1.7  $\mu\text{m}$ )

Assumes 10T, 17 MA, clean implosion (No mix, 3D, etc)

# 2D MHD simulations of our standard MagLIF configuration match experiments to within 2-3x

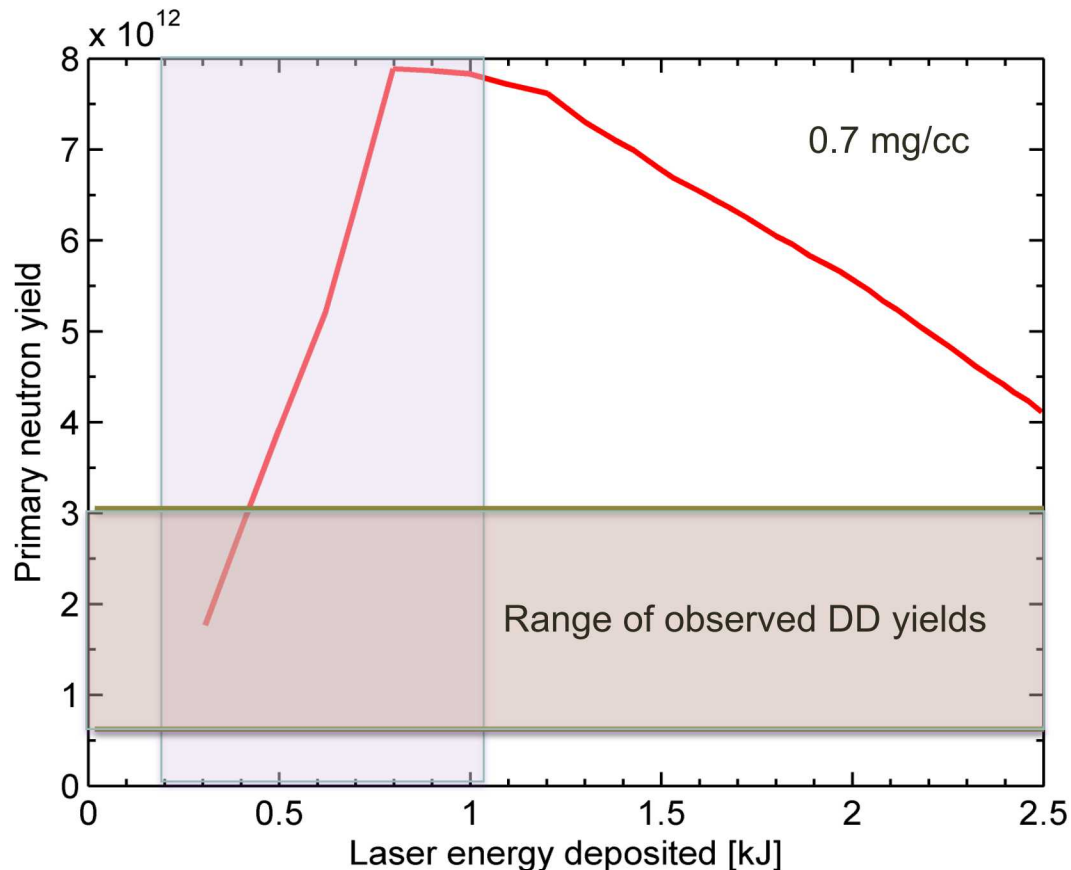

- 200-600J estimated coupled with thick ( $3.5 \mu\text{m}$ ) windows
- 600-1200J estimated for thin windows ( $1.7 \mu\text{m}$ )
- Similar performance obtained with both thin and thick windows
  - Thin windows more susceptible to high Z target components (mix)
  - Increased laser energy (4kJ) decreased performance

Assumes 10T, 17 MA, clean implosion (No mix, 3D, etc)

# Changes in laser preheat configurations have dramatically impacted the profile of energy deposition and window mix

## No Phase Plate

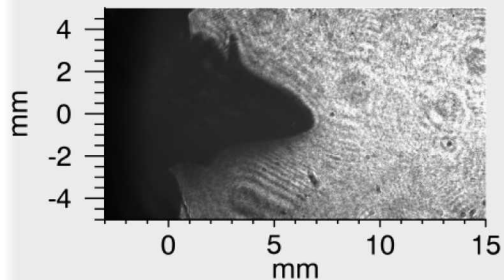

## Some Window Mix

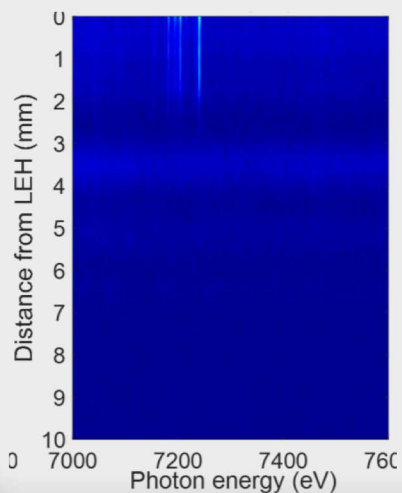

## Phase Plate

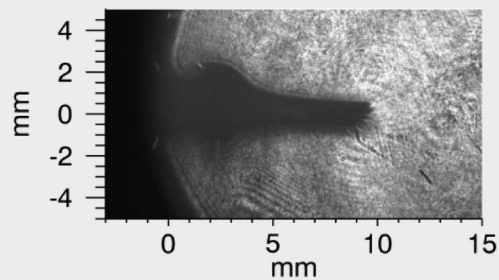

## Lots of Window Mix

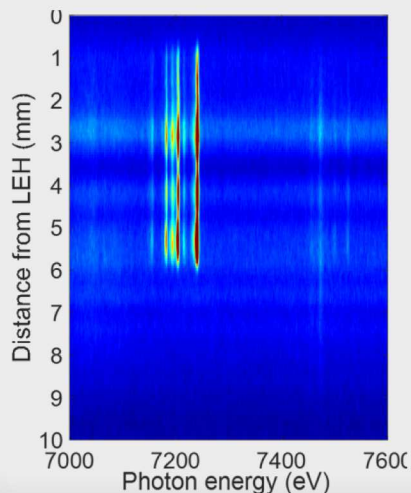

## Co-Injection w/ Phase Plate

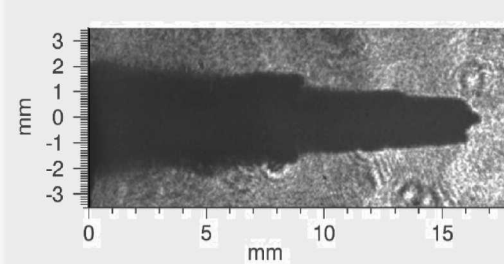

## Minimal Window Mix

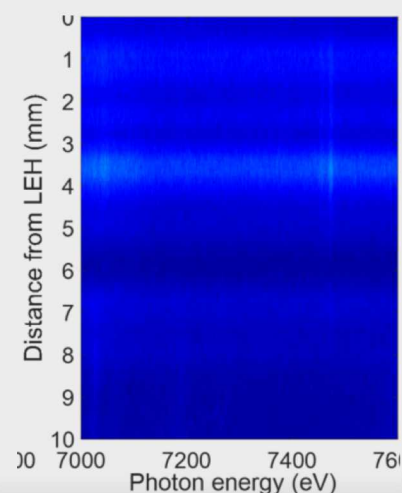

# OMEGA experiments show dramatic differences in $2\omega/3\omega$ laser propagation

SSD on  $3\omega$ , 1.5 ns,  $2.1 \times 10^{14}$  W/cm<sup>2</sup> SSD off

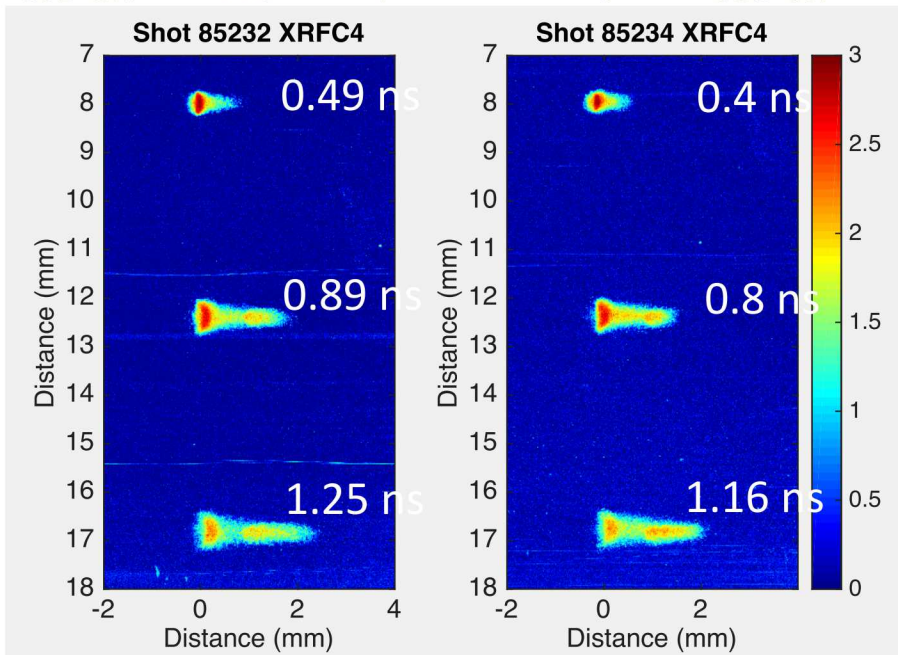

SSD off  $2\omega$ , 1.5 ns,  $\sim 2 \times 10^{14}$  W/cm<sup>2</sup> SSD

