

# RN Release Modeling

Presented by

Larry L. Humphries

[llhumph@sandia.gov](mailto:llhumph@sandia.gov)

# MELCOR Radionuclides and Decay Heat Release Models

---

- Four basic release models, with options
  - CORSOR, fractional release rate =  $A \exp(B T)$
  - CORSOR-M, fractional release rate =  $k_0 \exp(-Q/RT)$ 
    - Extended in MELCOR 1.8.5 from the original form to include release of classes 7 (Mo), 9 (La), and 11 (Cd)
  - CORSOR-Booth, based on Cesium diffusion  $D_0 \exp(-Q'/RT)$ 
    - Options for high- or low-burn-up fuel
  - Modified CORSOR-Booth
- Generalized Release Model
- Triso Fuel Release Model
- Structural Release of Ag-In-Cd control rod material

# MELCOR CORSOR-Booth

---

- Diffusion coefficient is a function of activation energy and temperature
  - D is scaled by the grain radius, a, to obtain D'
  - D't is unitless
- Cs release fraction, f(x), from approximate solution of Fick's law for spherical fuel grains
- Diffusion coefficient integrated over time is used in evaluation

$$D = D_0 e^{-\frac{Q}{RT}} \text{ and } D' = \frac{D}{a^2}$$

$$f(x) = 6 \sqrt{\frac{x}{\pi}} - 3x \quad \text{for } x < \frac{1}{\pi^2}$$

$$f(x) = 1 - \frac{6}{\pi^2} e^{-\pi^2 x} \quad \text{for } x > \frac{1}{\pi^2}$$

$$x = D't \sim \sum D' \Delta t$$

$$\text{ReleaseRate}_{Cs} = \frac{[f(\sum_{t+\Delta t} D' \Delta t) - f(\sum_t D' \Delta t)]}{(1 - RFRAC) \Delta t} V \rho$$

$$\text{Release Rate}_k = \text{ReleaseRate}_{Cs} \cdot S_k$$

# CORSOR-Booth Potential Underflow Issue

$$\text{ReleaseRate}_{Cs} = \frac{[f(\sum_{t+\Delta t} D' \Delta t) - f(\sum_t D' \Delta t)]}{(1 - RFRAC) \Delta t} V \rho$$

$$f\left(\sum_{t+\Delta t} D' \Delta t\right) - f\left(\sum_t D' \Delta t\right) = \frac{6}{\pi^2} \left[ e^{-\pi^2 \sum_t D' \Delta t} \right] - \left[ e^{-\pi^2 \sum_{t+\Delta t} D' \Delta t} \right]$$

- $\sum_t D' \Delta t$  increases monotonically
- MELCOR no longer evaluates exponent when  $\sum_t D' \Delta t > 5$ 
  - Returns a 0 release rate thereafter
  - Underflow occurs even sooner
- Consequently, release of Cs stops even though ‘theory’ would never allow depletion of Cs
  - All other radionuclides similarly stop releasing since they are scaled to Cs release
- Current model implementation breaks down for large diffusion times
  - CORSOR Booth probably not valid for large diffusion times

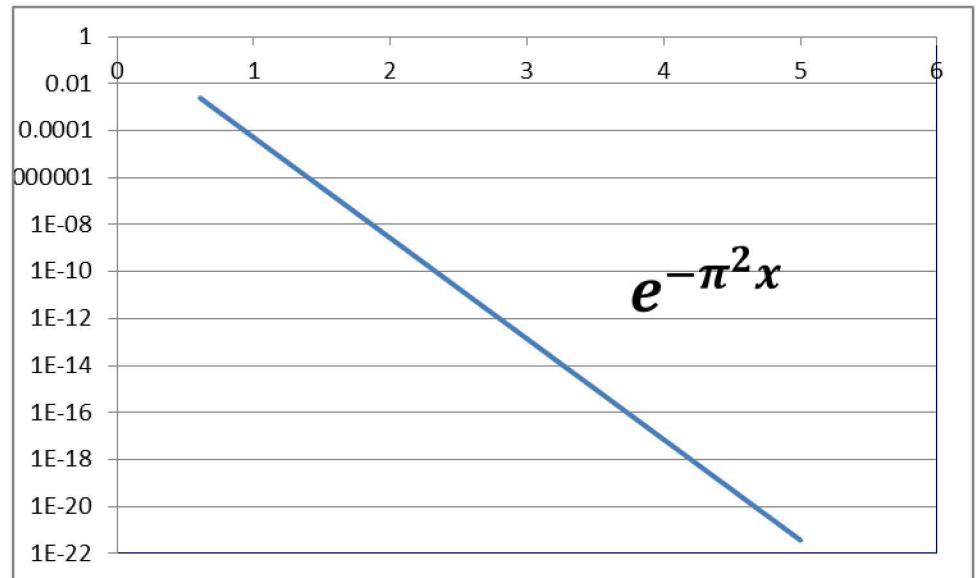

# CORSOR-Booth Inconsistency in Release fraction variables

RFRAC and  $f(x)$  are inconsistent representations of the release fraction

$$\mathbf{ReleaseRate}_{Cs} = \frac{[f(\sum_{t+\Delta t} D' \Delta t) - f(\sum_t D' \Delta t)]}{(1 - RFRAC) \Delta t} V \rho$$

- MELCOR has an inconsistent representation of the Cs release fraction ( $f$  and RFRAC)
  - Function  $f$  represents the Cs release fraction based on a Fick's law solution for fuel grains in a spherical geometry
  - Internally, MELCOR stores a variable RFRAC representing the fraction of Cs remaining in a component
    - Can be different due to modifications made due to gaseous mass transfer
  - Neither is tied to actual Cs mass inventories
- Equations for  $\frac{df}{dt}$  can be written in a form that uses the MELCOR internal RFRAC variable,
  - Calculation more consistent
  - Reduces some round-off issues

$$\mathbf{ReleaseRate}_{Cs} = \frac{V \rho}{(1 - RFRAC)} \frac{dRFRAC}{dt}$$

$$f(t) = 1 - \frac{6}{\pi^2} e^{-\pi^2 D' t} \text{ for } D' t > \frac{1}{\pi^2}$$

$$\frac{df}{dt}(t) = 6 D' e^{-\pi^2 D' t} \text{ for } D' t > \frac{1}{\pi^2}$$

$$\frac{df}{dt}(t) = \pi^2 D' (1 - f) \text{ for } D' t > \frac{1}{\pi^2}$$

$$\frac{dRFRAC}{dt}(t) = \pi^2 D' (1 - RFRAC) \text{ for } D' t > \frac{1}{\pi^2}$$

# CORSOR Booth – Numerical Problems with Derivative of Diffusion Approximation

- Approximation for diffusion release fraction is not continuous
  - Slight differences in release fraction
  - Significant discontinuity in derivative at  $D't=1/\pi^2$ 
    - Error on order of 50%
    - May have implications in fitting
      - Fitting should be cover entire range
    - Discontinuity in calculated release rate may be misinterpreted
- Considering using diffusion series solution

$$f(x) = 1 - \frac{6}{\pi^2} \sum_{n=1}^{\infty} \frac{1}{n^2} e^{-n^2 \pi^2 D't}$$

- gives better agreement at discontinuity
  - 3 or 4 terms is all that is needed for continuous derivative that is not infinite.
- However, many terms are required to obtain correct behavior as  $x \rightarrow 0.0$ 
  - Booth approximation for diffusion release fraction gives correct results in limit
  - 10 terms may be sufficient

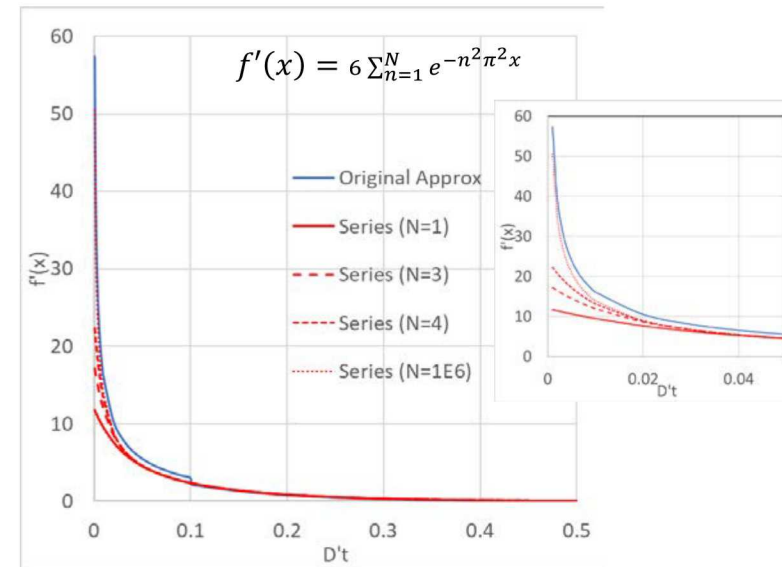
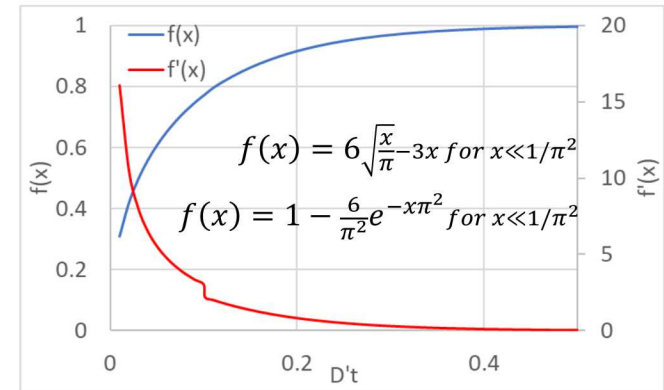

# CORSOR Booth – Diffusion

## Implementation

---

- The Booth scaling factors were derived to fit diffusion coefficients to be used for independent diffusion calculations for each class, not as multipliers to the CS release rates as it has been applied in the past. Consequently, a new Booth model has been developed
- New ORNL-Booth Model (to be released)
  - Proposed implementation (ICRLSE=7,-7)
  - Diffusion coefficients scaled to Cs diffusion coefficients and independent diffusion calculation for each class
    - Consistent with how diffusion coefficients were fit to data

$$= \int_0^{D't} \frac{f'_k}{1 - f_k} \cdot (1 - f_k)$$

- Existing Modified ORNL-Booth Model
  - Modified Booth Implementation(ICRLSE=5,-5)
  - Scale RN releases rates to Cs Booth diffusion release rate

$$= \int_0^{D't} S_k \frac{f'_{Cs}}{1 - f_{Cs}} \cdot (1 - f_k)$$

# Corrected Booth Modeling

## Using Scaled Diffusion Coefficients

- MELCOR diffusion coefficients scaled with ORNL Data

$$- D_{class} = S_{class} D_0 e^{-\frac{Q}{RT}}$$

- Perform diffusion calculation for each class using appropriate diffusion coefficient

$$- ICRLSE=7,-7$$

Diffusion Coeff, $D_0$	$1 \times 10^{-6} \text{ m}^2/\text{sec}$
Activation Energy, $Q$	$3.814 \times 10^5$ Joule/mole
$S_{XE}$	1
$S_{Cs}$	1
$S_{Ba}$	$4 \times 10^{-4}$
$S_I$	0.64
$S_{Te}$	0.64
$S_{Ru}$	0.0025
$S_{Mo}$	0.2
$S_{Ce}$	$4 \times 10^{-8}$
$S_{La}$	$4 \times 10^{-8}$
$S_{Cd}$	.25
$S_{Sn}$	.16

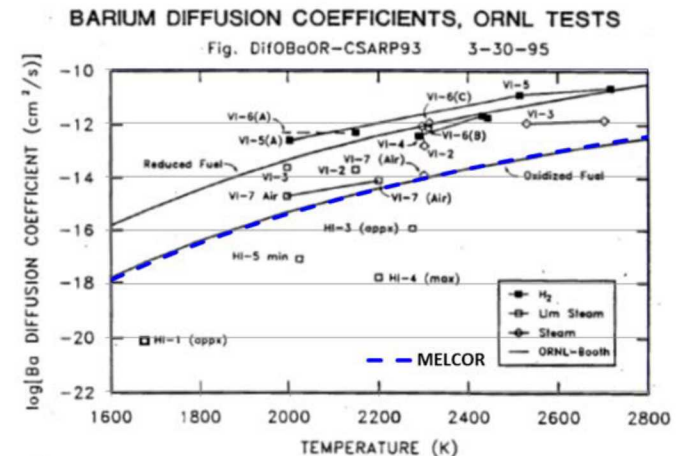
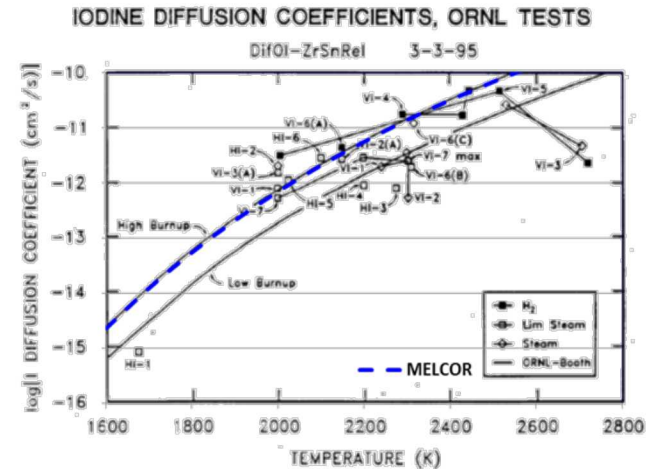

# Validation of corrected Booth-Diffusion Model

Barium

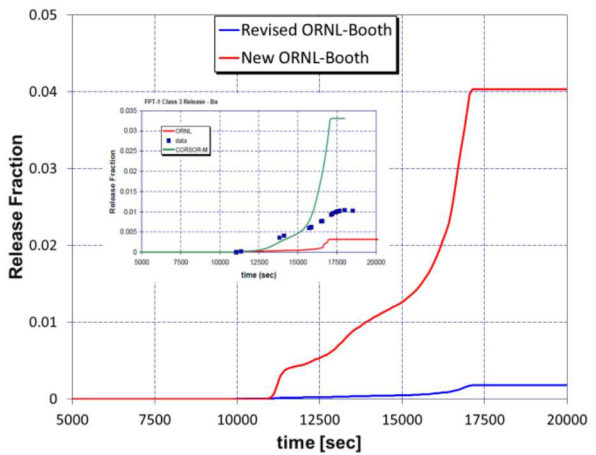

Iodine

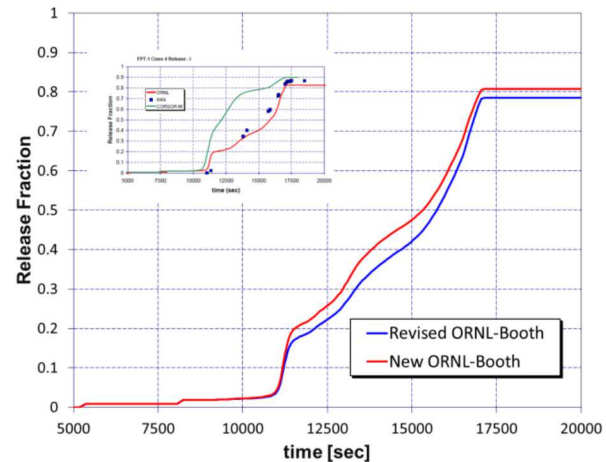

- Validation of model against FPT-1 experiment
  - ‘New ORNL-Booth’ (ICRLSE=-7,7) represents modeling based on scaling diffusion coefficients
  - Release is only changed for those RNs with diffusion scale factors much less than unity
    - Comparison of Barium release
      - Diffusion coefficient is orders of magnitude smaller than Cs (scale factor =  $4 \times 10^{-4}$ )
      - Predicts larger release fraction than observed
        - » May need to be adjusted
      - Predicts much larger release fraction than ‘Revised ORNL-Booth’ (ICRLSE=-5,5) though relative error is about the same
      - Note inconsistencies in ‘Total’ and ‘Total Released’ in text output
        - » Round-off issues leads to 30% error
        - » May account for error in release fraction (in part)

RELEASED RADIOACTIVE RADIONUCLIDE MASS AUDIT - MASSES IN KG

CLASS	TOTAL RELEASED	AEROSOL MASSES		VAPOR MASSES		DEP MASS	FILTERS	CHEM AB	PHYSDEP
		GAS	LIQUID	GAS	LIQUID				
XE	2.819E-02	0.000E+00	0.000E+00	2.819E-02	0.000E+00	0.000E+00	0.000E+00	0.000E+00	0.000E+00
CS	9.708E-03	1.181E-02	0.000E+00	4.256E-03	2.224E-20	0.000E+00	5.242E-03	0.000E+00	2.095E-04
BA	4.704E-04	6.211E-04	0.000E+00	1.826E-04	0.000E+00	0.000E+00	2.878E-04	0.000E+00	0.000E+00

- Comparison of I<sub>2</sub> Release
  - Very Slight differences
  - Diffusion coefficient scale factor close to unity (0.65)

# CORSOR-Booth

## Gaseous mass transport

$$\dot{m}_k = \left[ Nu \frac{D_{k,gas}}{D_{fuel}} \right] \cdot A_{fuel} \cdot \left( \frac{P_{k,eq}}{RT} - \rho_{k,free} \right) \quad \text{Gas-phase mass transfer from heat transfer analogy (free stream density of all RNs assumed zero)}$$

- CORSOR-Booth Model (ICRLSE=3,-3)
  - Mass transfer term removed from effective release rate before scaling other RNs

$$ReleaseRate_{Cs} = \frac{[f(\sum_{t+\Delta t} D' \Delta t) - f(\sum_t D' \Delta t)]}{(1-RFRAC)\Delta t} V \rho$$

$$DIFF_{Cs} = \left[ \frac{1}{ReleaseRate_{Cs}} - \frac{1}{\dot{m}_{Cs}} \right]^{-1}$$

$$DIFF_k = DIFF_{Cs} \cdot S_k$$

- Revised CORSOR-Booth Model (ICRLSE=5,-5)
  - Mass transfer term not removed from Cs release rate
    - Assumes ReleaseRate only accounts for diffusion

$$DIFF_k = ReleaseRate_{Cs} \cdot S_k$$

- Mass transfer term added back to each RN  $\dot{m}_k = [1/DIFF_k + 1/\dot{m}_k]^{-1}$

# Gaseous Transport of RNs relative to Moles of UO<sub>2</sub> in Volume

- Note that RM indicates Cs release rate is fractional release multiplied by  $\rho V$ 
  - Where V is volume and  $\rho$  is UO<sub>2</sub> molar density
  - New model uses actual class inventory
- Note however that release rate is divided by  $\rho V$  before multiplying by RN inventory to obtain mass released
- Even so, scaling by  $\rho V$  is important in comparing diffusion release rate with gas release rate

## Old Modeling

$$ReleaseRate_{Cs} = \frac{[f(\sum_{t+\Delta t} D' \Delta t) - f(\sum_t D' \Delta t)]}{(1 - RFRAC_{Cs}) \Delta t} \rho V$$

$$\dot{f}_k \text{ (fraction/s)} = \frac{\dot{m}_{tot,k}}{\rho V} \left[ F - \frac{P_{k,bulk}}{P_{k,eq}} \right]$$

$$\dot{m}_k = [1/DIFF_k + 1/\dot{m}_k]^{-1}$$

## New Modeling

$$ReleaseRate_{Cs} = \frac{[f(\sum_{t+\Delta t} D' \Delta t) - f(\sum_t D' \Delta t)]}{(1 - RFRAC_k) \Delta t} Mass_{k,component}$$

$$\dot{f}_k \text{ (fraction/s)} = \frac{\dot{m}_{tot,k}}{Mass_k} \left[ F - \frac{P_{k,bulk}}{P_{k,eq}} \right]$$

$$\dot{m}_k = [1/DIFF_k + 1/\dot{m}_k]^{-1}$$

# CORSOR-Booth Strictly Valid in Fuel

---

- CORSOR-Booth release rate is dependent on the release history (diffusion dependence) since concentration differentials vary over time.
  - Release fraction for fuel is well characterized and does not involve any material that has moved
  - All other components associated with ‘transported’ fuel material as a result of melting (conglomerate) or loss of structural support PD
  - MELCOR ‘blends’ release fractions after transport but the results may not be meaningful
    - Consider blending material which has had no release with material that has almost complete release. Averaging over mass makes little sense.
    - Would require tracking distributions of release fractions for each component
- Alternative would be to allow CORSOR-Booth in fuel material but other release models for other components
  - CORSOR-M and CORSOR release rates are strictly temperature dependent.
  - Include resistance from gas-phase mass transport.

# Modification for Te Release

---

- The presence of unoxidized zirconium can lead to a reduction in release rate of the tellurium class.
  - Te reacts with Zr forming products with low vapor pressure
  - The release rate of Te is reduced by a release rate multiplier (with a default value of  $1/40 = 0.025$ ) until the mass of unoxidized intact metal cladding falls below a cut-off fraction (default value of 0.7) of the total mass of intact cladding (including the oxide mass).
- The parameters are sensitivity coefficients
  - array 7105 for CORSOR and CORSOR-M
  - Array 7107 for CORSOR-Booth

*T. Nakamura and R. A. Lorenz, "Effective Diffusion Coefficients Calculated from ORNL FP Release Test Results," Oak Ridge National Laboratory Research Paper (April 1989).*

# Comparison to Experiment

---

- Original CORSOR-Booth class scaling factors were modified based on ORNL-VI results
  - Dominate Cs species changed from CsI to  $\text{Cs}_2\text{MoO}_4$
  - FP releases adjusted based on Phebus-FPT1
    - Data on several species
    - Improved early release rates and total release
  - Results compared again to ORNL-VI, VERCORS
    - Only Cs from VERCORS-2, others also from VERCORS-4
- Results using modified ORNL-Booth scaling much improved over original CORSOR-Booth

# PHEBUS Facility

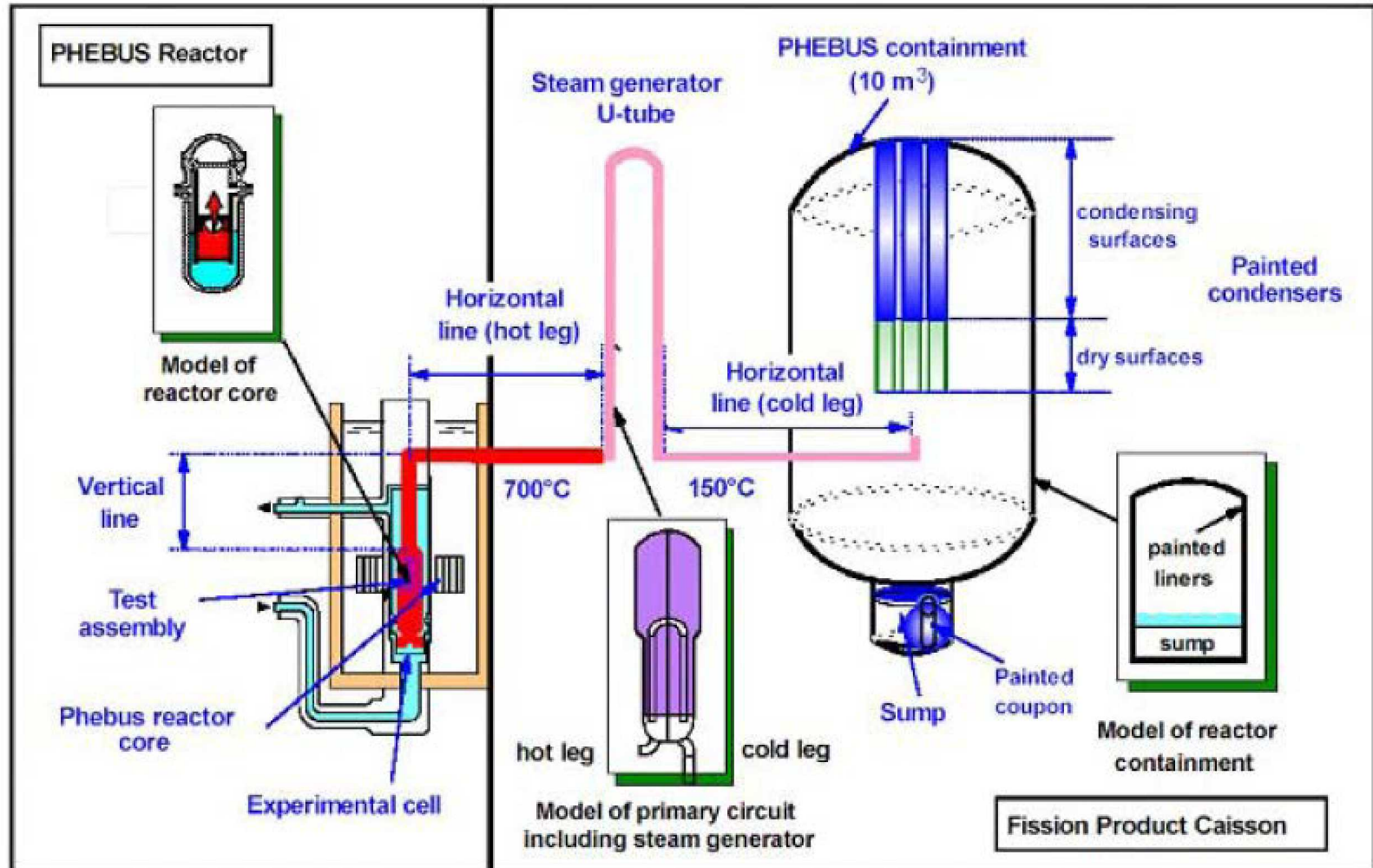

# FPT-1 Cs Release

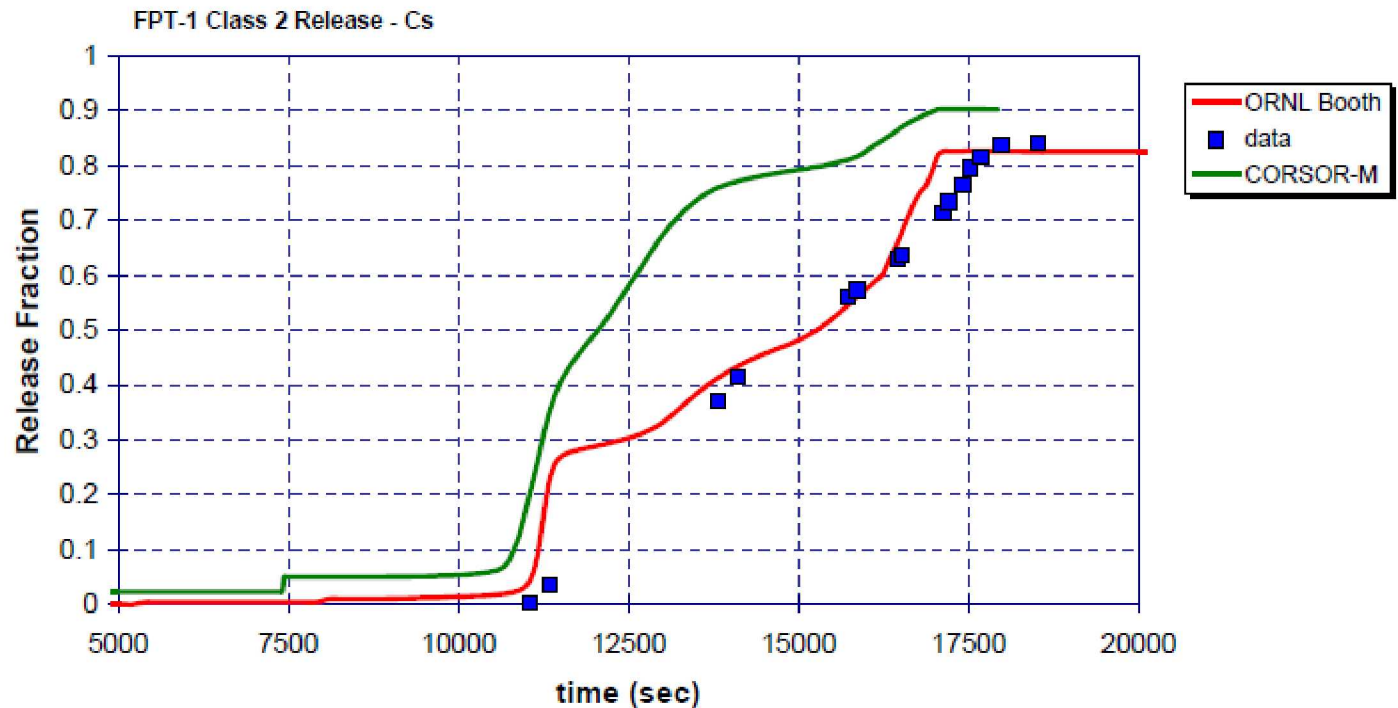

# FPT1 Ba, I, Te and Mo Release

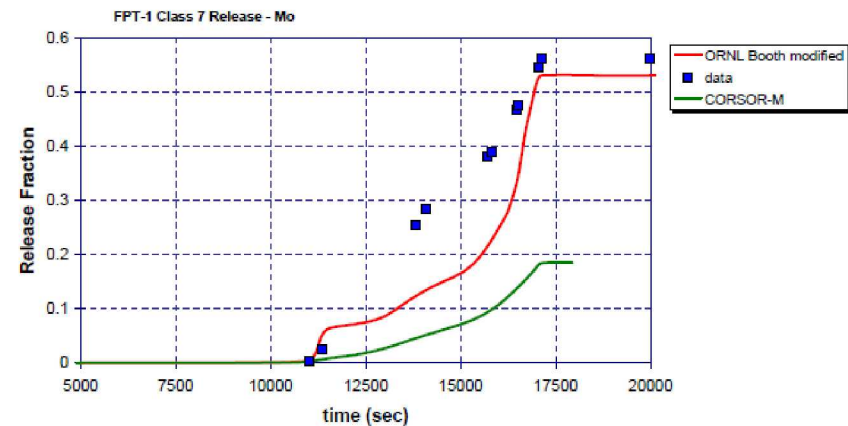
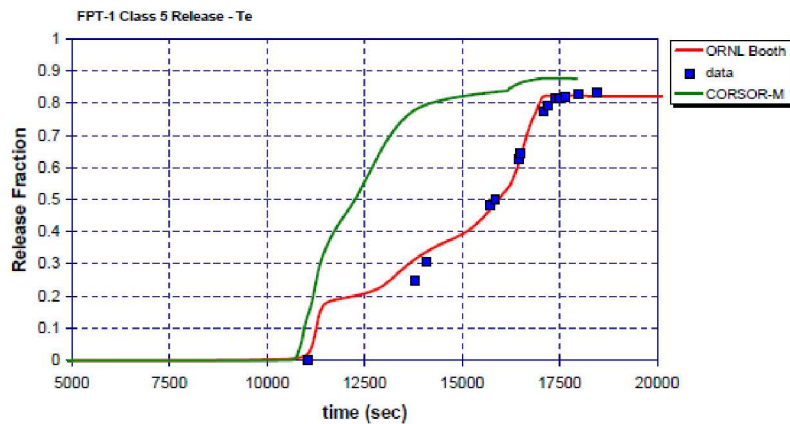
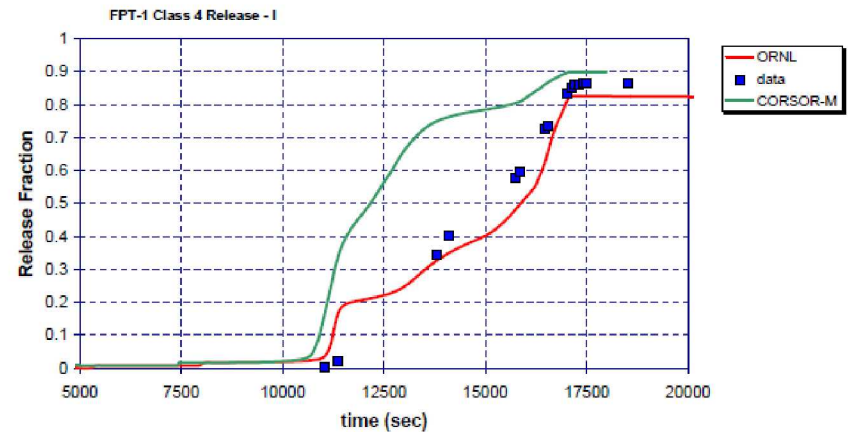
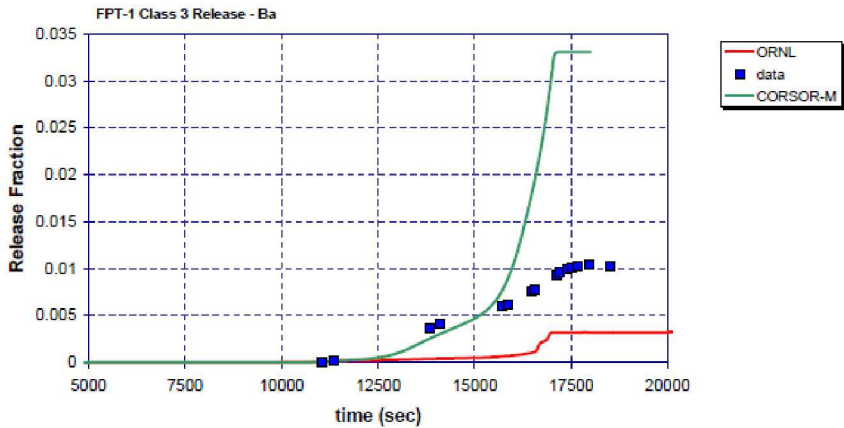

# VERCORS Facility

*G. Ducros et al. / Nuclear Engineering and Design 208 (2001) 191–203*

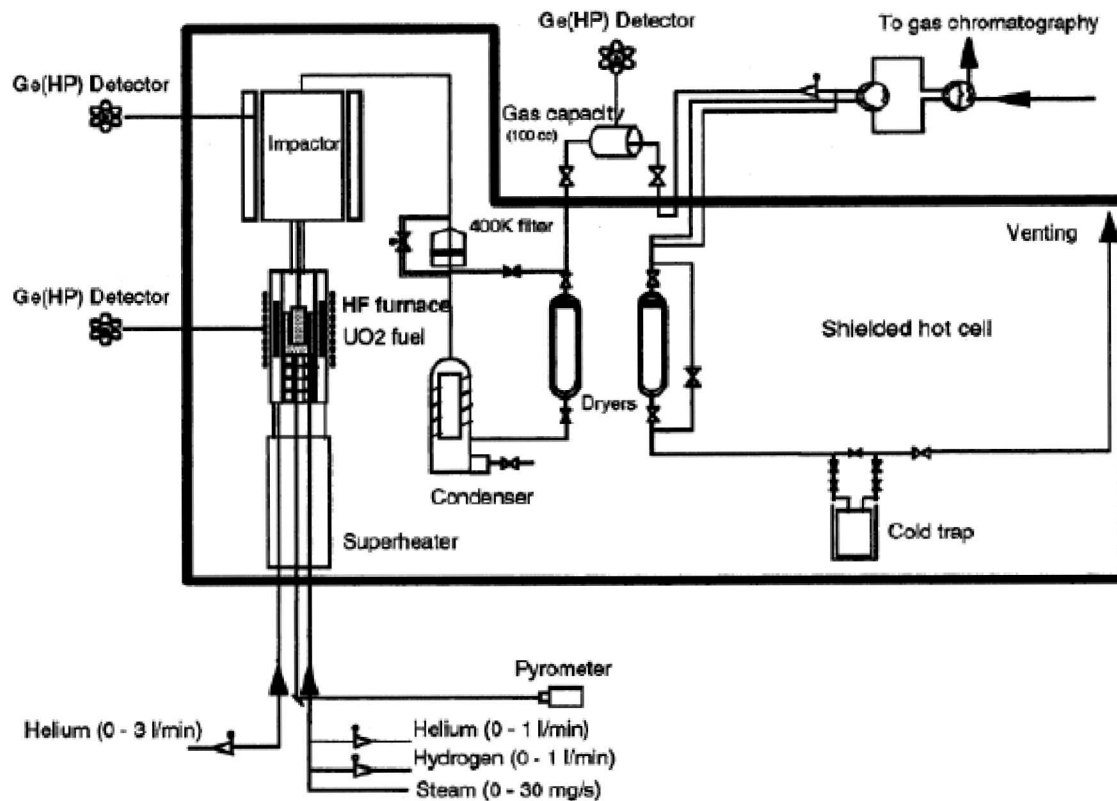

# VERCORS 2 Cs

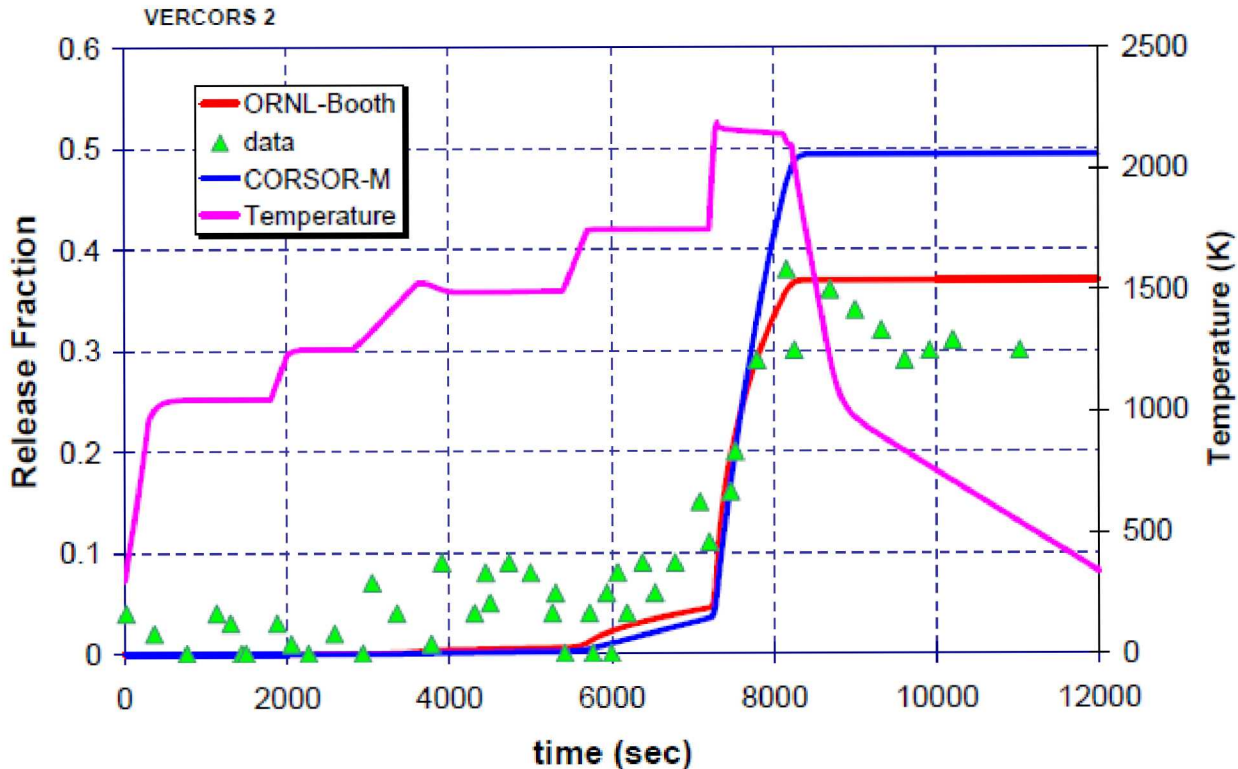

# VERCORS 4 Cs

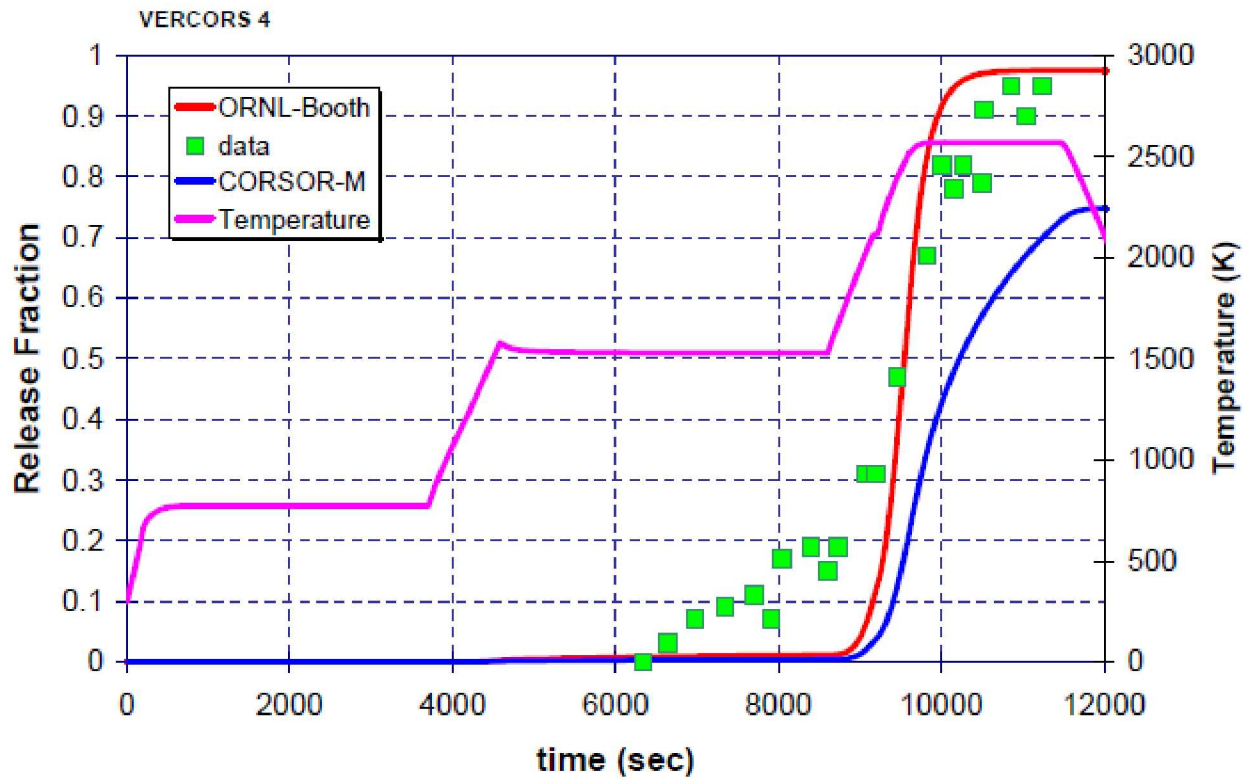

# VERCORS-4 Other FPs

Te

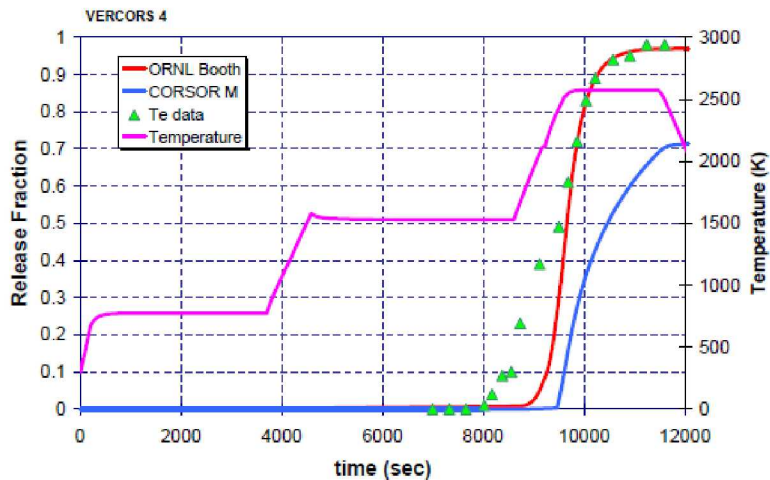

Ba

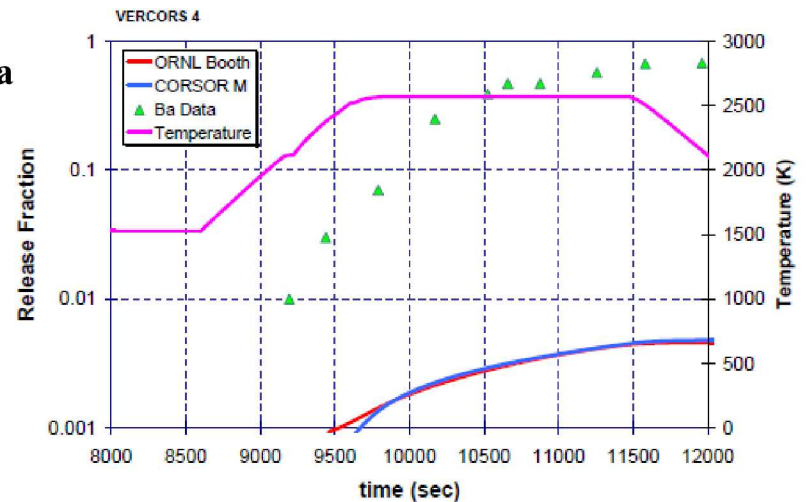

Mo

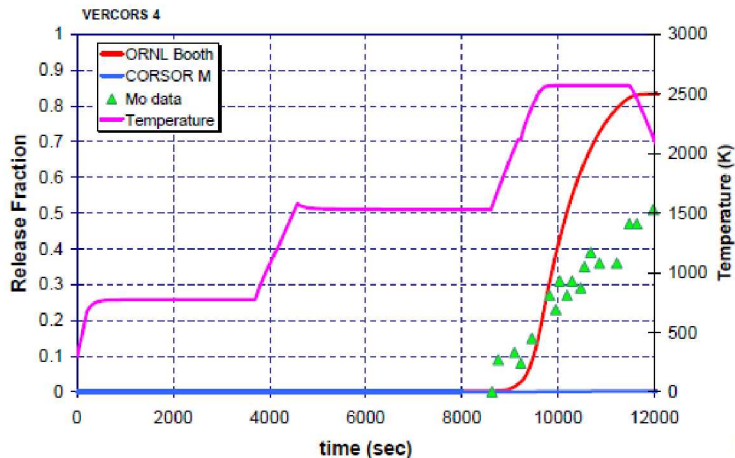

I

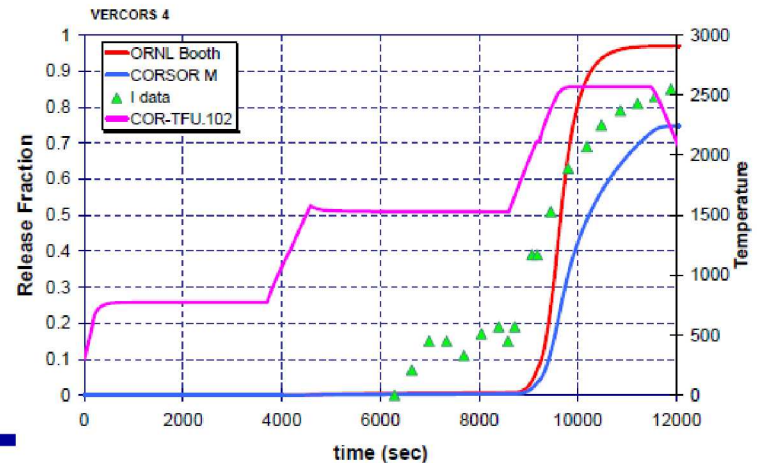

# Generalized Fission Product Release Model

- A cumulative burst fission product release fraction is described by the following equation:

$$FB_{j,i} = a\_burst_j(c_0 + c_1 * T_i + c_2 * T_i^2 + c_3 * T_i^3)$$

Where

$T_i$  is the fuel temperature that existed during the time interval  $Dt_i$

$c_0, c_1, c_2, c_3$  are constant coefficients provided in user input

$a_j$  is a constant class dependent coefficient provided in user input.

- A cumulative diffusive fission product release fraction is described by the following equation:

$$FD_{j,i} = b\_diff_j(FD_{j,i-1} + (1 - FB_{j,i-1} - FD_{j,i-1}) \cdot [1 - e^{-kd_{j,i} \Delta t_i}])$$

Where

$FD_{j,i}$  is the cumulative fraction of diffusive fission product released up to time  $t_i$

$B\_diff_j$  is a constant class dependent coefficient provided in user input

$FD_{j,i-1}$  is the cumulative fraction of diffusive fission product released up to time  $t_{i-1}$

$FB_i$  is the cumulative fraction of burst fission product released up to time  $t_i$

$[1 - e^{-kd_{j,i} \Delta t_i}]$  is the fractional release due to diffusion during the time interval  $Dt_i$

$kd_{j,i}$  is the release rate coefficient for fission product class  $j$  calculated using the temperature,  $T_i$ , that existed during the time interval  $Dt_i$

$$kd_{j,i} = A_j e^{-B_j / (RT_i)}$$

Where  $A_j$  and  $B_j$  are class dependent coefficients provided in user input.

# Generalized Fission Product Release Model

- The total cumulative fission product release fraction at time  $t_i$  for fission product  $j$  is determined by:

$$F_{j,i} = d\_total_j \cdot (FB_{j,i} + FD_{j,i})$$

- The cumulative release fraction cannot exceed the amount of fission product available

$$FB_{j,i} = FB_{j,i-1} \text{ and } FD_{j,i} = FD_{j,i-1} \text{ when } FD_{j,i} \geq 1.0$$

- The derivative of the cumulative burst release with respect to time cannot be less than zero; if the temperature decreases, the cumulative burst release remains constant.

$$FB_{j,i} = FB_{j,i-1} \text{ when } T_{i-} \geq T_{B-max} \text{ or } T_{melting}$$

- The cumulative burst release reaches its maximum when the fuel temperature reaches  $T_{B-max}$  or  $T_{melting}$  whichever is lower

$$FB_{j,i} = FB_{j,i} \text{ when } T_i \geq T_{B-max} \text{ or } T_{melting}$$

# HTGR Fission Product Release

---

- HTGR release includes phenomena not in LWRs
  - Failure and release is spread out over time
    - Low level release during operation
      - Circulating activity
    - Accident release time is much longer: 50-100 hrs
  - Dust present in primary system
- Phenomena considered
  - TRISO particle failure
  - Release
  - Dust generation and transport
  - U contamination of matrix

# TRISO Particle

---

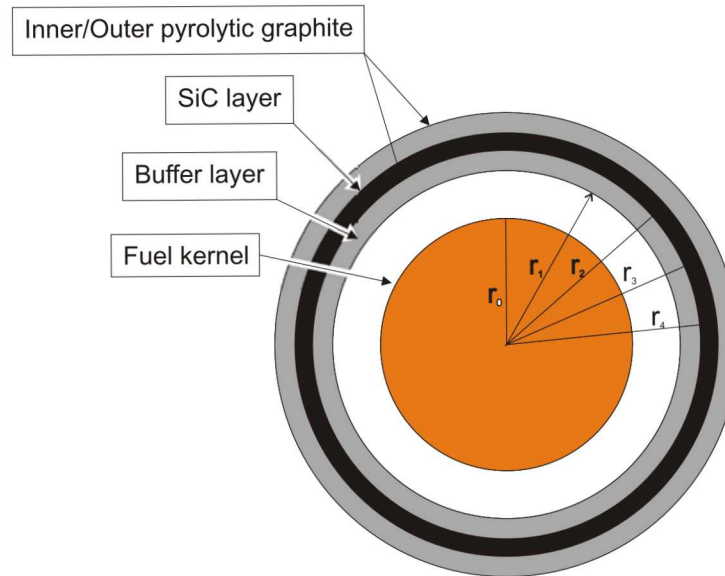

# MELCOR Approach for FP Model

---

- Input required from other codes
  - FP inventory – ORIGEN
  - Power shape, axial and radial profiles
  - Reactivity feedback parameters for point kinetics
- For HTGR, require some other initial input
  - Some from experimental data, ie
    - Initial particle failure fraction
    - Dust generation rate
  - Distribution of dust and FP
    - In particle, kernel vs buffer
    - In primary system, dust distribution

# HTGR Evaluation Process

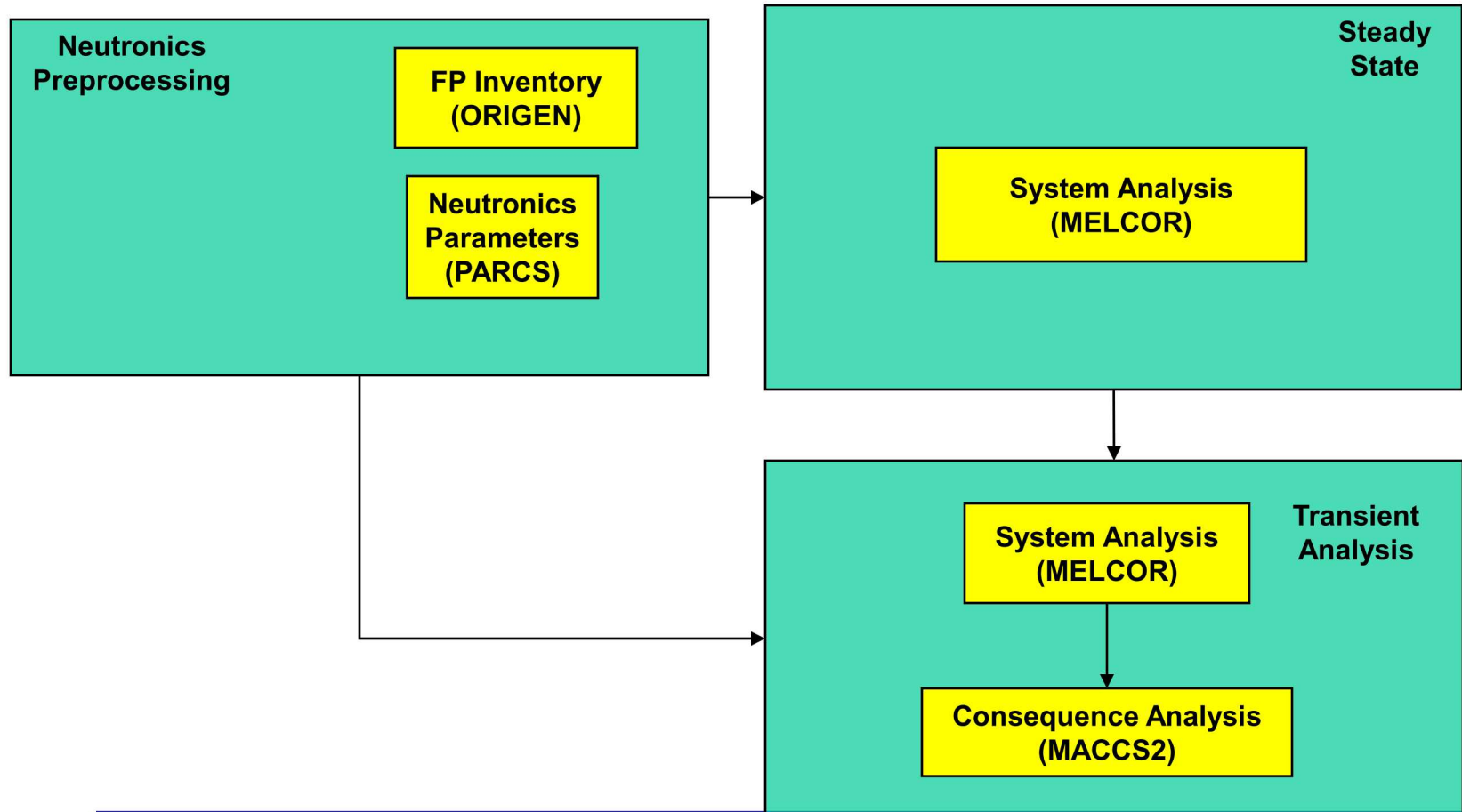

# MELCOR Initial Operation Phase

---

- Do “accelerated” normal operation run with MELCOR to get FP and dust distribution
  - This problem would be run long enough to establish trends and/or equilibrium for burnup cycle (~3 yrs)
  - Some FP release during operation
  - Dust generated at given rate in core
  - Transported and deposited using MELCOR CVH/RN packages
- Scale to desired operating time (~10 yrs)
- Use as starting conditions for accident scenario

# MELCOR Transient Phase

---

- Use steady state results and provided inventory, neutronic results, etc. at start of accident scenario
- Transient calculation using
  - FP release model
  - Transport of FP and resuspended dust via MELCOR CVH/RN packages
  - User input Failure Curve
    - Particle failure fraction vs temperature, or
    - Failure surface from PARFUME

# MELCOR FP Model - Release

---

- Kernel release to buffer region
  - Diffusion
  - Recoil
- Release from intact particles
  - controlled by SiC layer
- Release from failed particles
  - FP in buffer layer + further release from kernel
  - Can be further holdup in matrix
- U contamination of matrix in manufacture

# FP Diffusion Model

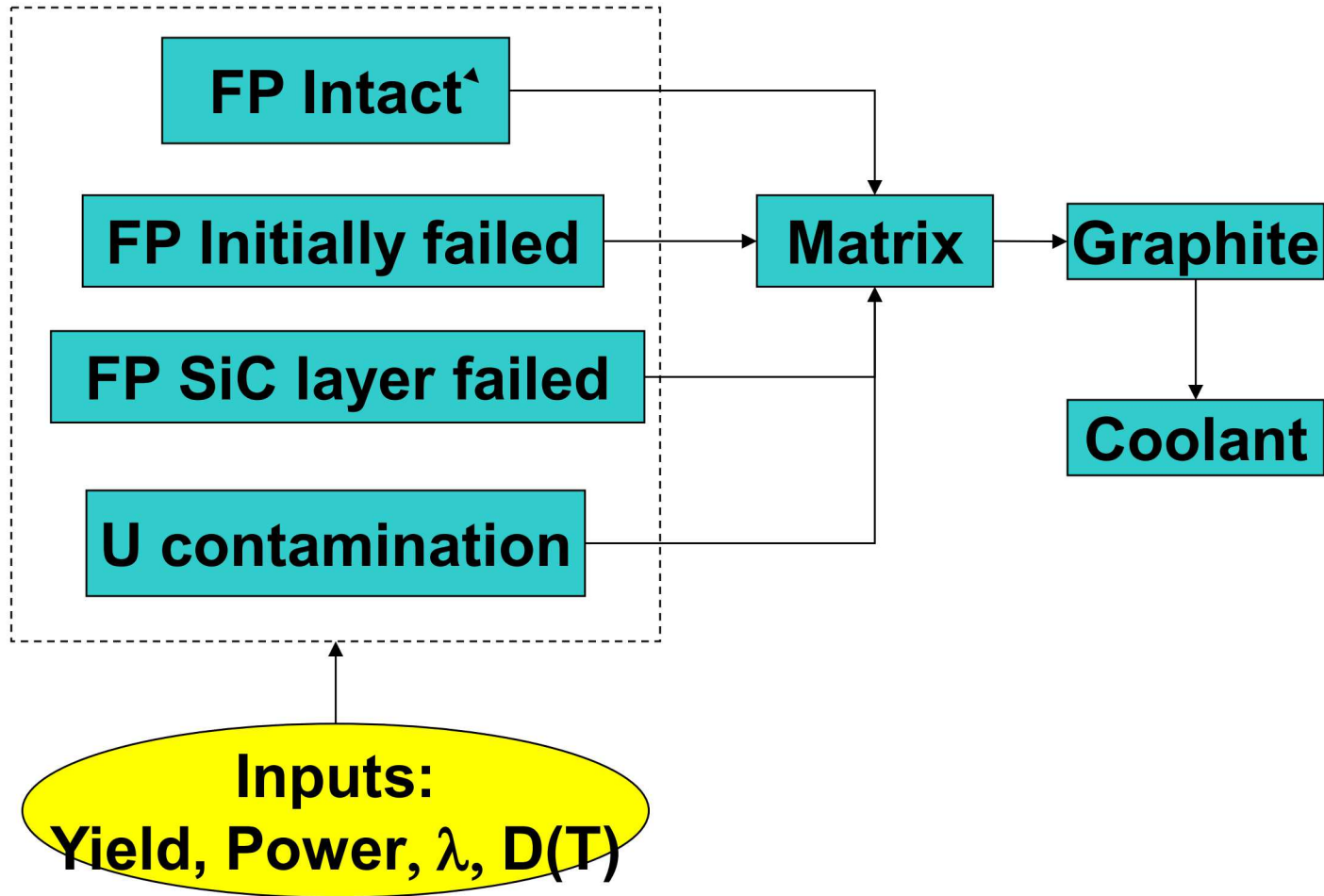

# Cesium Diffusion in Intact TRISO

---

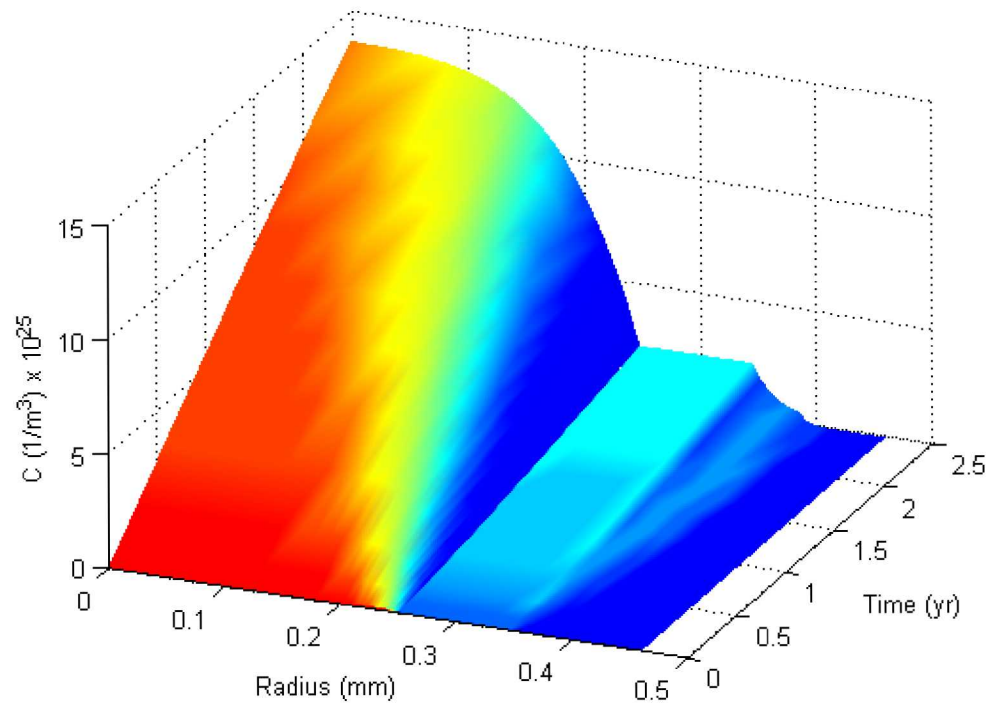

# MELCOR FP Model - Dust

---

- Dust generation
  - No verified analytic models available currently
  - Only experimental evidence from GT-MHR, AVR
  - Parametric model in MELCOR
- Dust transport and distribution
  - Need initial distribution in primary system for accident
    - MELCOR transport calculation for operation
    - Provided by user
  - Resuspension
    - Current models not well developed
    - Force balance/parametric liftoff model
  - FP adsorption on dust

# Total Release from Failed Particles

---

- Particles fail at different times during accident
  - Convolution integral of failure rate and release fraction

$$F_{tot}(t) = \int_0^t \frac{dF_W(\tau)}{d\tau} F_R(t - \tau) d\tau$$

where  $F_{tot}$  = Total release fraction

$F_W$  = Failure fraction

$F_R$  = Release fraction of particle

# Total Release contd

---

- Convolution integral collapses to simple integral if:
  - Release approximates a delta function
  - Release is treated as kernel release
    - To buffer for intact particles
    - To coolant for failed particles

# DLOFC Cs Release for Convolution and Failure Fraction times Kernel Release Fraction

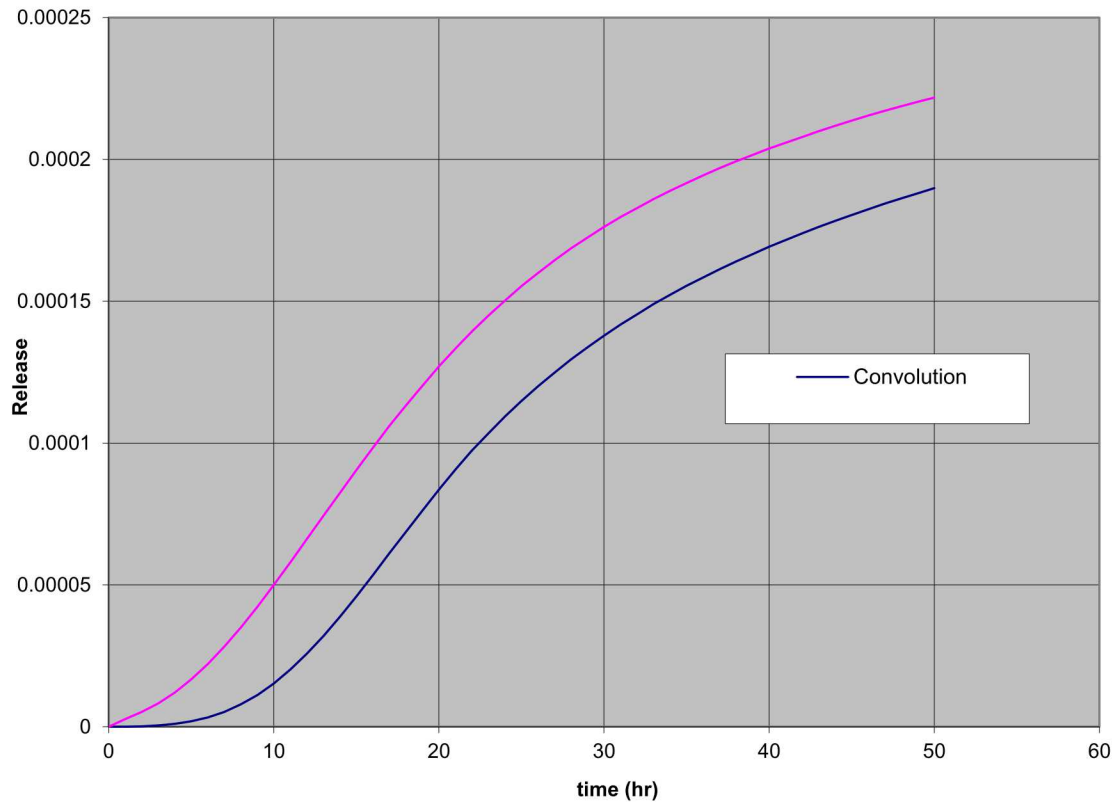

# Ag/In/CD Release From Control Rods

- FPT-1 Post-test analysis demonstrated the importance of predicting structural aerosol release of CR materials
- MELCOR has a single alloy material to represent all three component materials
  - Vapor pressure of alloy taken as the component with smallest vapor pressure
  - Composition of remaining unvaporized alloy does not change
    - In reality, cadmium would vaporize quickest, followed by indium, then silver, and the composition of the molten alloy would change.
- MELCOR assumes vaporization controlled by mass diffusion in the gas
  - Cooling by vaporization ignored
  - Condensation of vapor not allowed

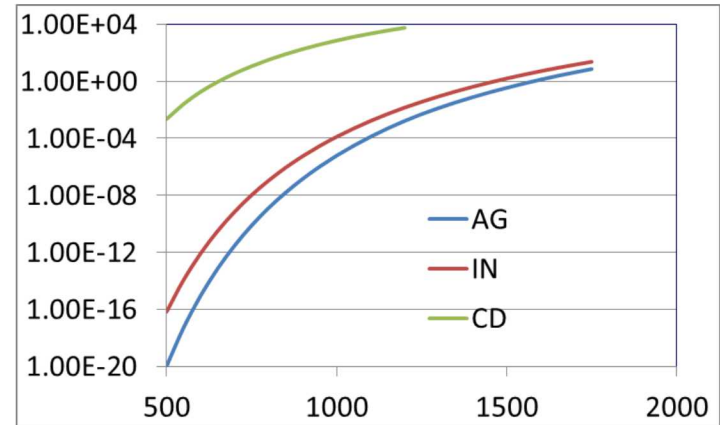

$$\dot{m}_{vap} = h_m A_c M_{Ag} \left( \frac{P_v(T_c)}{RT_c} - \frac{P_{Ag}(T_b)}{RT_b} \right)$$

*Mass transfer analogy*

# Ag/In/CD Release From Control Rods

---

- Model is not enabled by default COR\_CR record

*COR\_CR ACTC*

- User must also specify three new RN classes AG-CR, IN-CR, CD-CR

– Vapor pressure (C7110), diffusion coefficients (C7111), and molecular weights (C7120) must also be defined

## (1) IAICON

Turns on the silver release model

### (a) 0 or NACT

Model is not active. No additional fields are required.

### (b) 1 or ACTC

Model is active, vaporization is allowed from candling material only

### (c) 2 or ACTDC

Model is active, vaporization is allowed from both candling material and conglomerate

(type = integer / character\*5, default = 0, units = none)

The following fields are required if and only if IAICON = ACTC or 1, ACTDC or 2. If they are not set, then the default values will be used:

## (2) ARATIO

The area ratio of break area to control rod internal cross-sectional area. This cannot be greater than 1.

(type = real, default = 0.1, units = none)

## (3) AKFRCT

The flow loss coefficient used in the release velocity calculation. If input, this will override the value calculated according to the formula given in the reference manual.

(type = real, default = 0.32\*(1.0 - ARATIO), units = none)