

Model Reduction for Large-Scale Computational Simulations

Jeffrey A. Fike, Irina K. Tezaur, Kevin T. Carlberg

Uncertainty Quantification (UQ) methods seek to assess the effects of uncertainties on the predicted performance of a system.

Sampling-based UQ methods require many system analyses, but high-fidelity simulations of complex systems may take on the order of weeks on thousands of processors.

Our goal is to investigate the feasibility of using reduced-order models as surrogates for the high-fidelity analysis in order to reduce the computational cost of UQ

- Need sufficient accuracy, stability, and computational efficiency

Reduced-order modeling capabilities have been embedded in two high-fidelity analysis codes:

- **Albany**, a Multi-Physics Finite Element Code
- **SPARC**, a Computational Fluid Dynamics Code

Non-Linear Model Reduction Using Discrete Projection

Offline Stage

Step 1: Collect training data:

- Run Full-Order Model (FOM) to generate snapshots of the state

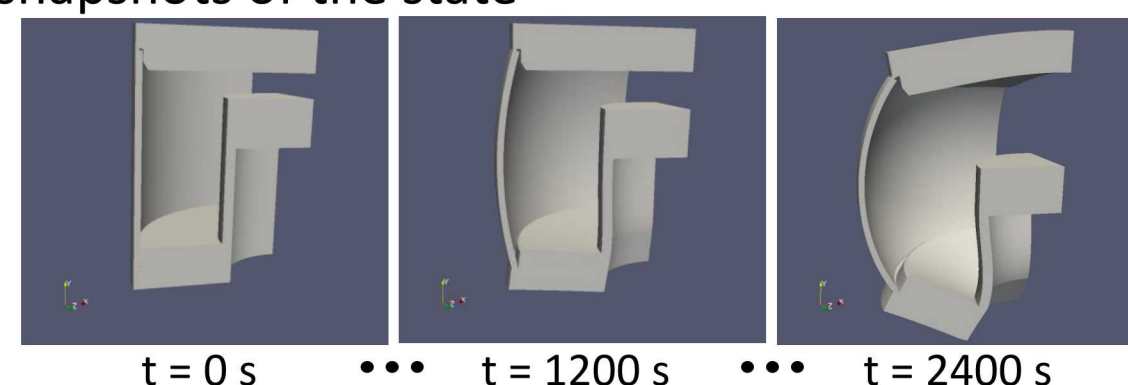

Step 2: Construct a modal basis Φ using Proper Orthogonal Decomposition (POD):

- Reduces dimension of problem from $O(10^6)$ degrees of freedom to $O(100)$ modal coefficients

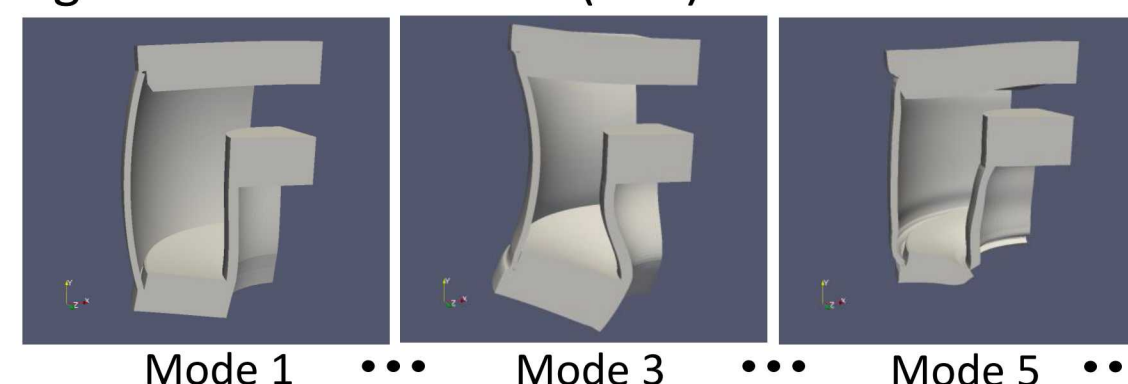

Step 3: Construct a sample mesh:

- Hyper-reduction techniques **reduce computational cost** by only evaluating residual and Jacobian on a subset of the full mesh

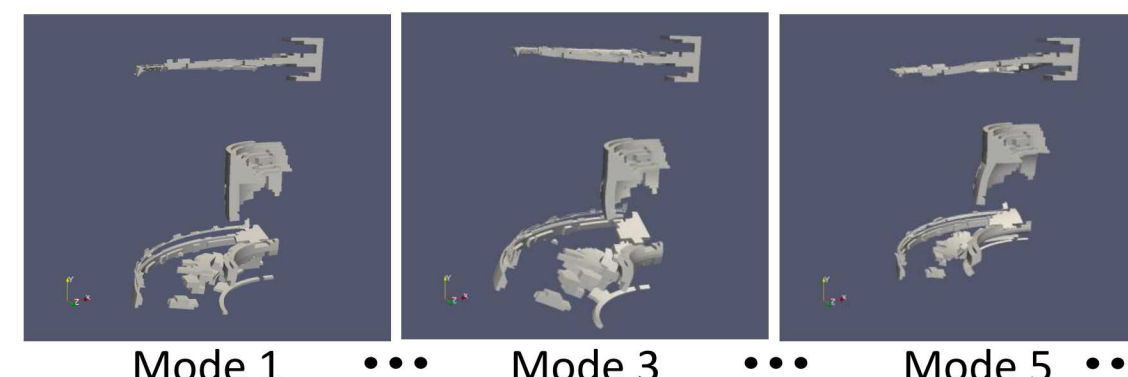

Online Stage

- Run non-linear Reduced-Order Model (ROM) using capabilities embedded in analysis code
- Projection occurs at the discrete level

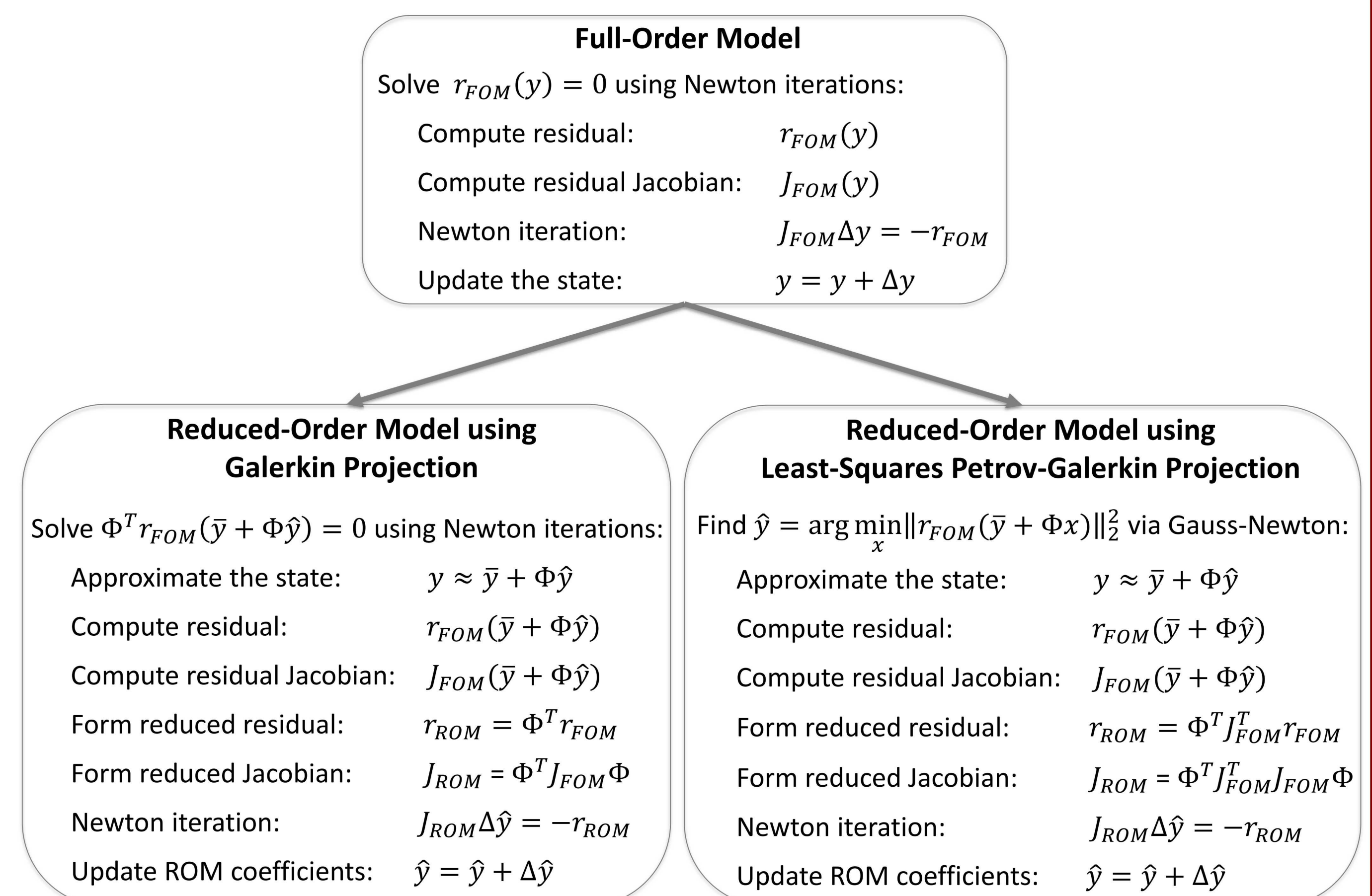

Implementation in High-Fidelity Analysis Codes

Albany

- Multi-Physics Finite-Element Analysis Code
 - Mechanical and Coupled Thermo-Mechanical Systems, Atmospheric Modeling, Ice Sheet Modeling, Quantum Device Design, Fluid Dynamics Simulations
- Uses a Model Evaluator concept, to compute the residual and Jacobian as required by whatever solver is used
 - Allows solvers to be decoupled from the physics
 - A Reduced-Order Model Evaluator wraps the Full-Order Model Evaluator to produce the required reduced residual and Jacobian evaluations

Large-Scale Mechanical System with Pressurized Interior

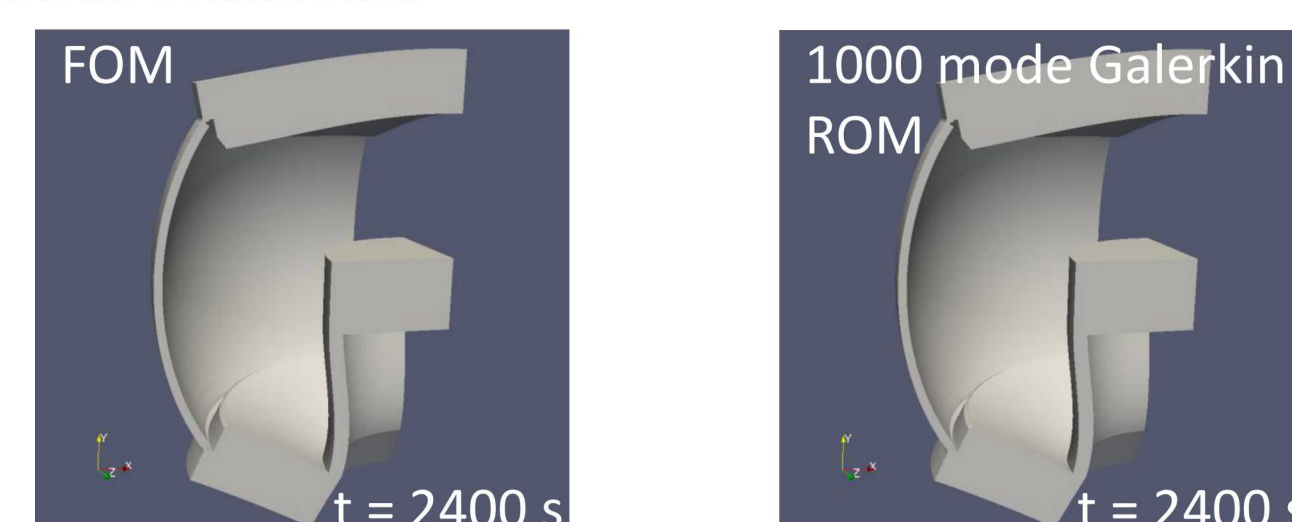

Coupled Thermal-Mechanical System

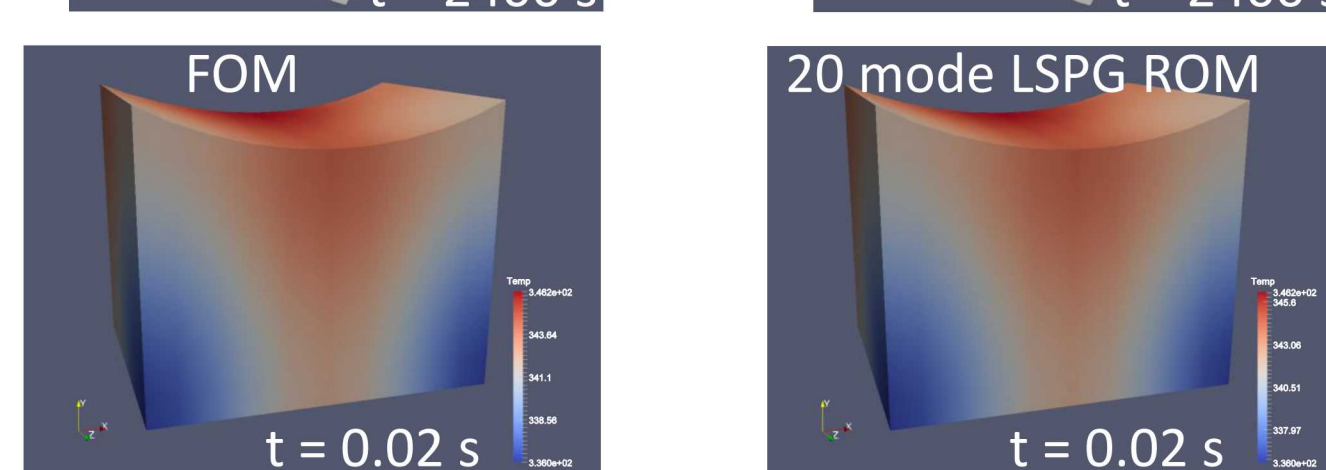

SPARC

- Cell-Centered Finite-Volume, Computational Fluid Dynamics Code
- Target application for model reduction is transonic, compressible, turbulent flow
 - Chaotic system, i.e. small changes result in different instantaneous behavior
 - Reproduce statistical quantities rather than instantaneous behavior
 - Requires long time integration
- For UQ, need to run the ROM at conditions outside training data
 - Parameter variations, i.e. Mach number, Reynolds number, etc.
 - Integration in time beyond snapshot collection period

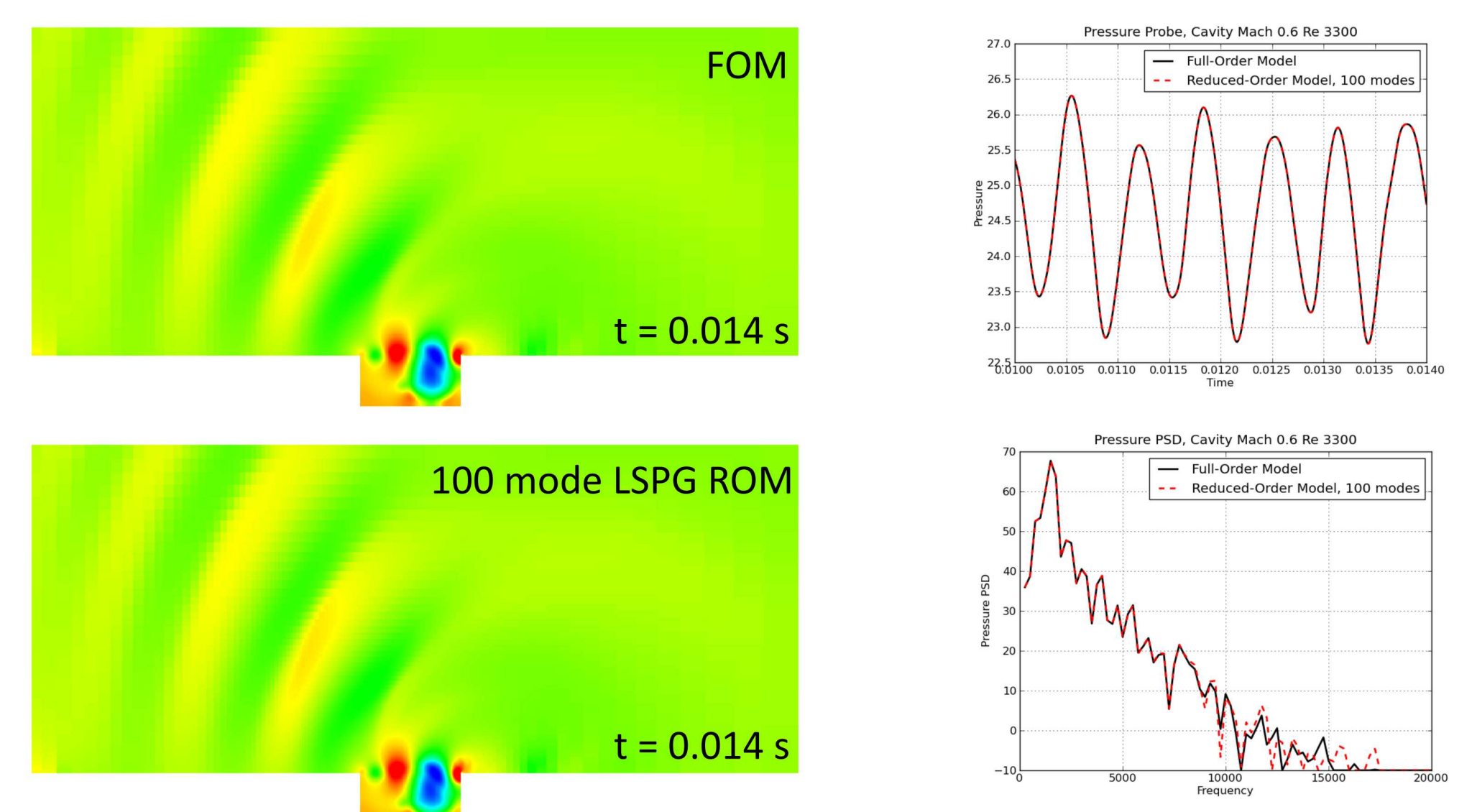

Summary and Future Work

Need non-linear reduced-order models with sufficient accuracy, stability, and computational efficiency in order to reduce computational cost of UQ

Model reduction capabilities using discrete projection have been embedded in two high-fidelity analysis codes: SPARC and Albany

These capabilities are undergoing continuous improvement with the near term goal of implementing the GNAT method (Carlberg et al. 2013)

The implementations serve as a testbed for research on model reduction, such as: basis stabilization, time parallel ROMs, physics-based constraints, and improved hyper-reduction methods



Exceptional
service
in the
national
interest