

PIV Measurements of Flame-Strain Rate Interactions and Fuel Injection Dynamics

J. H. Frank, B. Coriton, L. M. Pickett, P. Sphicas,
S. A. Skeen, A. Ruggles, J. C. Oefelein, A. Ruiz

*Combustion Research Facility
Sandia National Laboratories
Livermore, CA*

Mediterranean Combustion Symposium

Motivation

Fundamental understanding of turbulence-chemistry coupling
Multi-dimensional, time-dependent measurements required

Turbulent Flows in Canonical Geometries

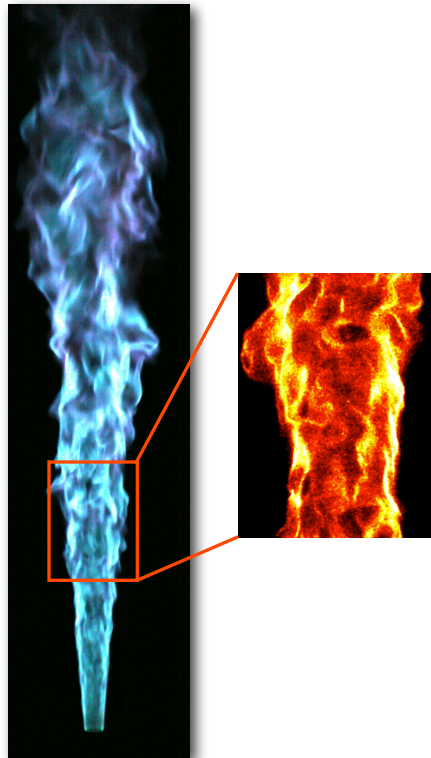

Challenging Environments

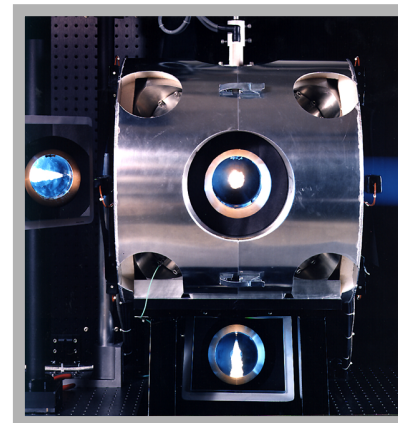
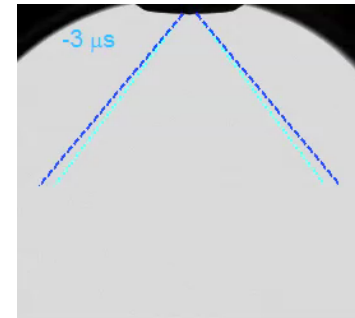

Structure of Turbulence Impacts Rates of Molecular Mixing

Temperature

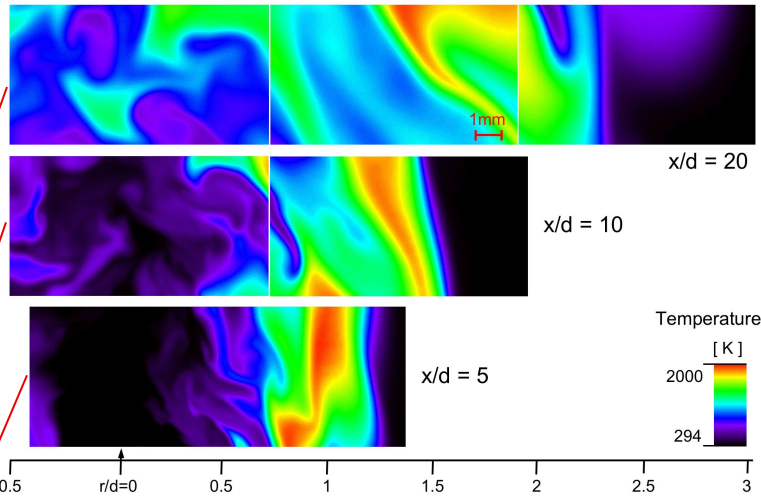

$\log(|\nabla T|^2)$

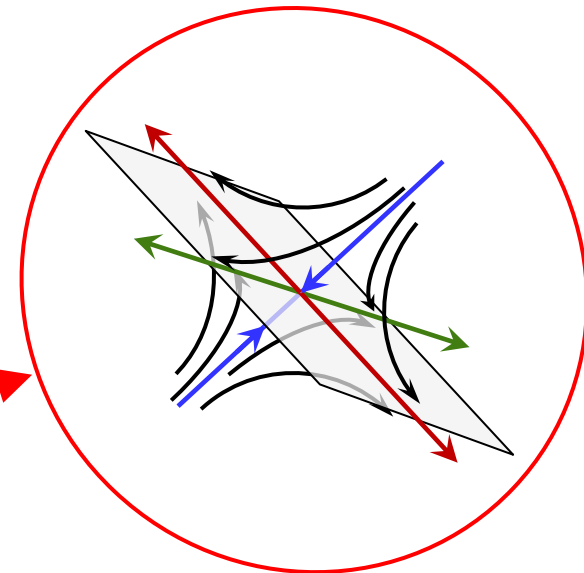
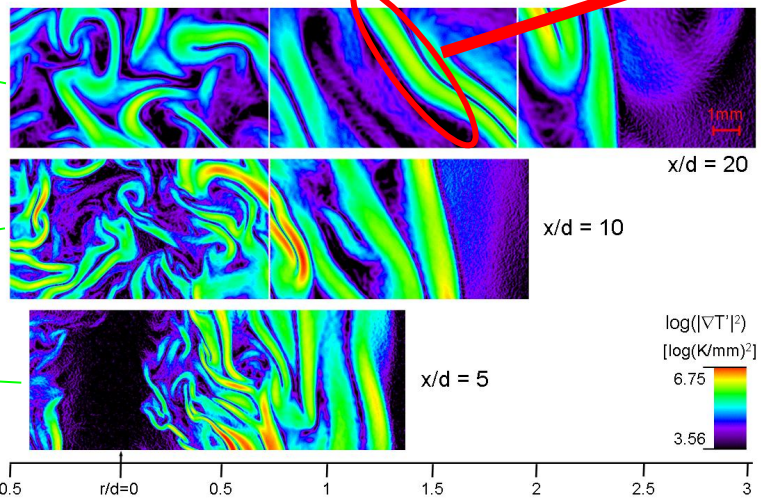

Feedback between
turbulence and combustion

Requires measurements of
fluid dynamics and
thermochemical state

3-D Measurements of Flow Fields in Turbulent Flames

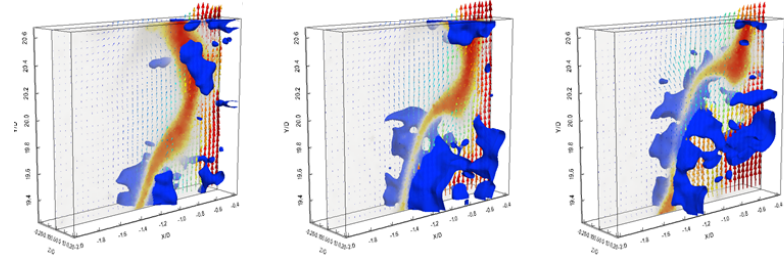

Coupling Tomo-PIV with Large Eddy Simulations

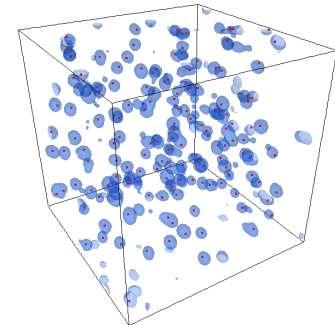
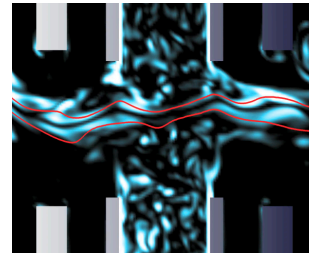

Dynamics of Transient Flows in Challenging Environments

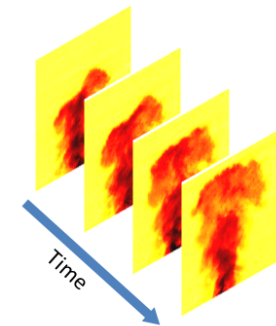
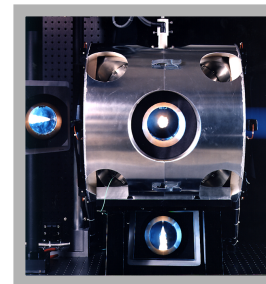

Measuring Structure of Turbulence

Tomographic Particle Imaging Velocimetry (PIV)

Tomographic Particle Image Velocimetry: 3-Component volumetric velocity measurements

Key fluid dynamic quantities measured at multi-kHz rates



$$\mathbf{v} = u\hat{i} + v\hat{j} + w\hat{k}$$

Velocity gradient tensor $\nabla \mathbf{v} = \frac{\partial u_i}{\partial x_j}$

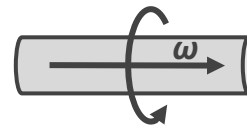

Vorticity $\boldsymbol{\omega} = \nabla \times \mathbf{v}$

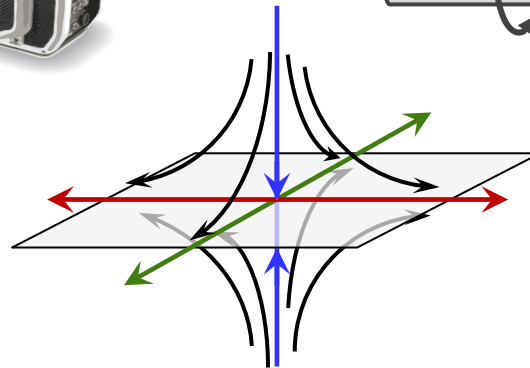

Strain rate tensor $S_{ij} = \frac{1}{2} \left(\frac{\partial u_i}{\partial x_j} + \frac{\partial u_j}{\partial x_i} \right)$

Measurements at multi-kHz rates

Tomo-PIV Data Acquisition and Processing

Frame A

Camera 1

Camera 2

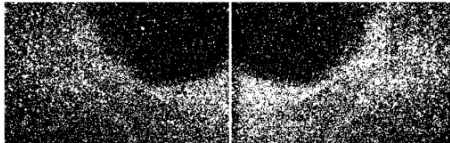

Camera 3

Camera 4

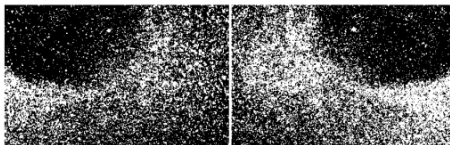

Frame B

Camera 1

Camera 2

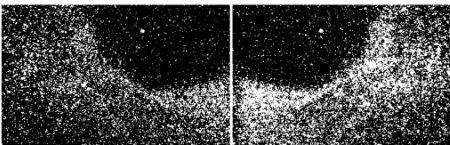

Camera 3

Camera 4

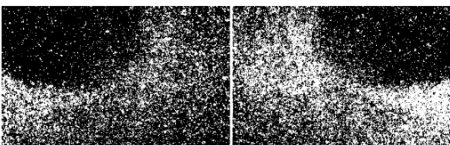

Data Acquisition

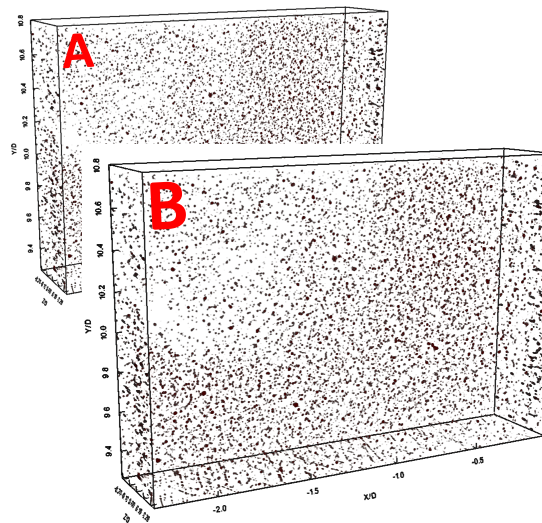

Probe Volume Reconstruction
(multiplicative algebraic
reconstruction tomography)

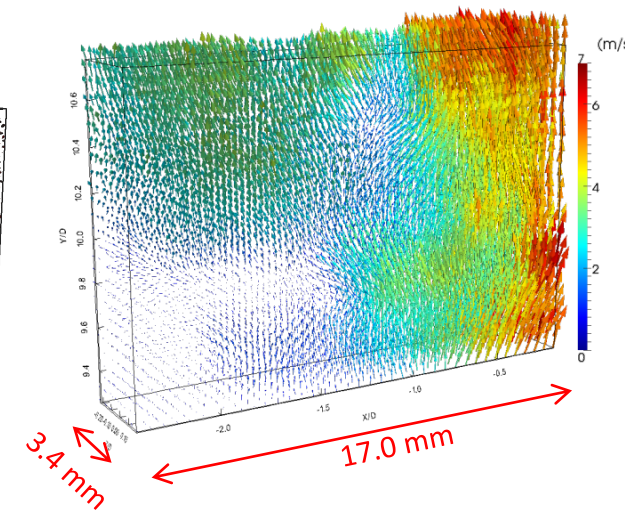

Volume Cross-Correlation
to Calculate Particle
Displacements

Tomo-PIV Data Processing

Volume Cross-Correlation

Flame products

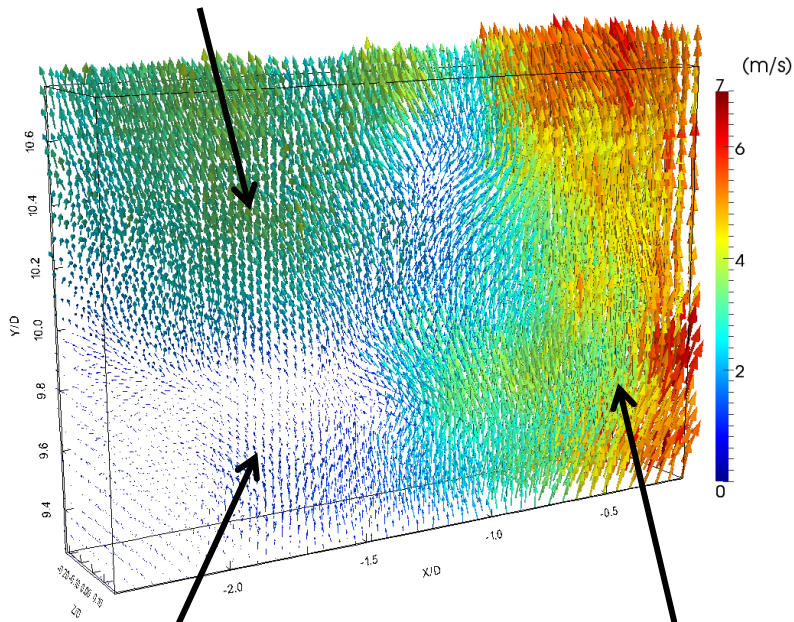

Coflow stream

Jet flow

1 out of 64 vectors plotted

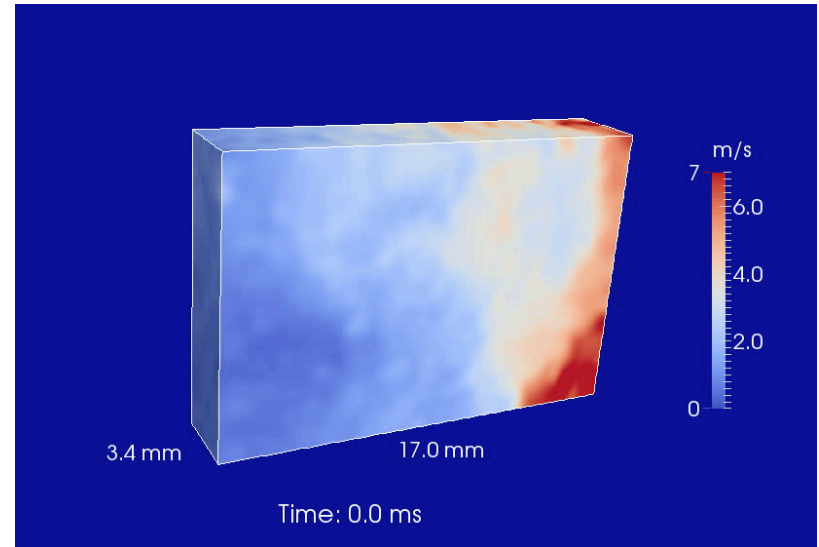

3D velocity field measured at 10 kHz

Volume per vector: $413 \times 413 \times 413 \mu\text{m}^3$
 $24 \times 24 \times 24 \text{ vx}$
 with 75% overlap

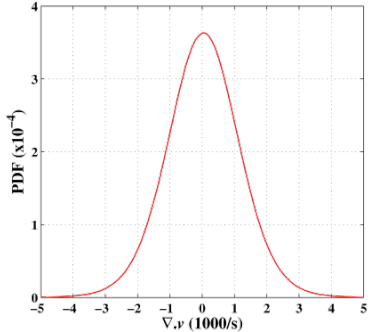

Tomo-PIV Measurement Uncertainty

Sources of errors (estimate based on measurements in...)	Velocity uncertainty	Derivative uncertainty
Noise, Thermophoretic diffusion, Volume reconstruction errors (Laminar counterflow flame)	1-10 cm/s	$O(100) \text{ s}^{-1}$
Inherent spatial & temporal averaging of PIV, Apparent transport of ghost particles (Turbulent Air jet)	Max. uncertainty for unresolved eddies $\sim 0.8 \text{ m/s}$	$O(1,000) \text{ s}^{-1}$ PDF of Apparent Divergence 
Beam steering (Turbulent jet flame)	$< 1\%$ for v $< 5\%$ for u and w (Coriton et al., Exp. Fluids, 2014)	$< 1,000 \text{ s}^{-1}$

Temporal and Spatial Resolution Considerations

Resolved scales vs. turbulent flow scales

- PIV measurement resolution
 - Interrogation region: $360 \times 360 \times 360 \mu\text{m}^3 = 24 \times 24 \times 24 \text{ vx}$
 - $f_{\text{piv}} = 10\text{-}16 \text{ kHz}$ ($\tau_{\text{piv}} = 62.5\text{-}100 \mu\text{s}$), $\Delta t = 4\text{-}20 \mu\text{s}$

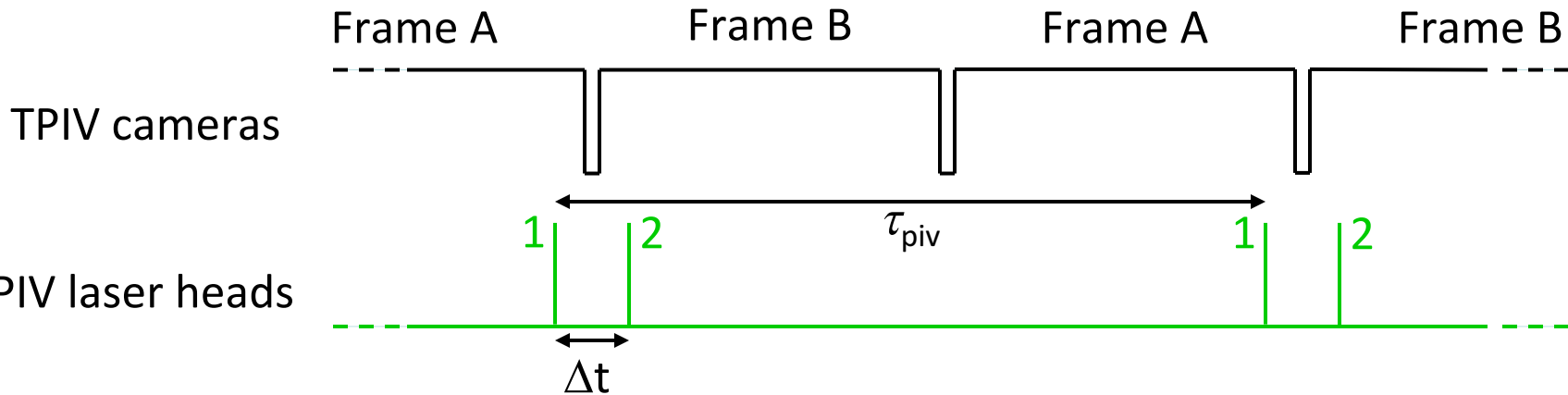

- Finest scales of flow field in canonical burner geometries
 - Kolmogorov scales: $\eta_k \approx 10\text{-}100 \mu\text{m}$ $f_k \approx 5 \text{ kHz}\text{-}100\text{'s kHz}$
 - $f_{\text{Nyquist}} = 2f_k$

Experimental Configuration

Tomographic PIV + OH LIF Imaging

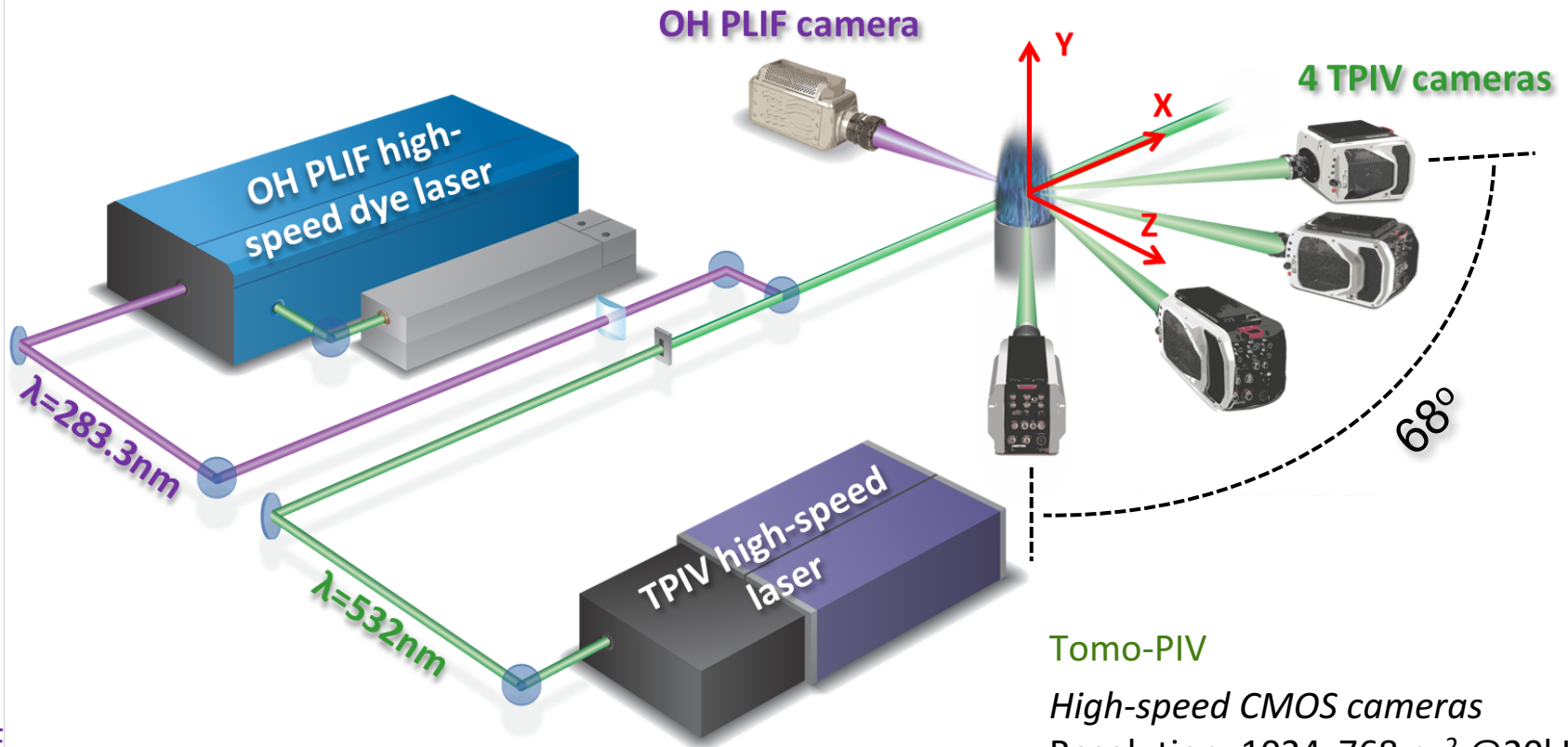

OH LIF

Nd:YAG-pumped dye laser
E = 90 uJ/pulse @ 10 kHz

Tomo-PIV

High-speed CMOS cameras
 Resolution: 1024x768 px² @20kHz
Dual-Head Nd:YAG laser
 Each Head: 50W @ 10-40 kHz

Interaction of Chemical Heat Release with Fundamental Processes in Turbulence

Partially-premixed flame with high mean shear, local extinction

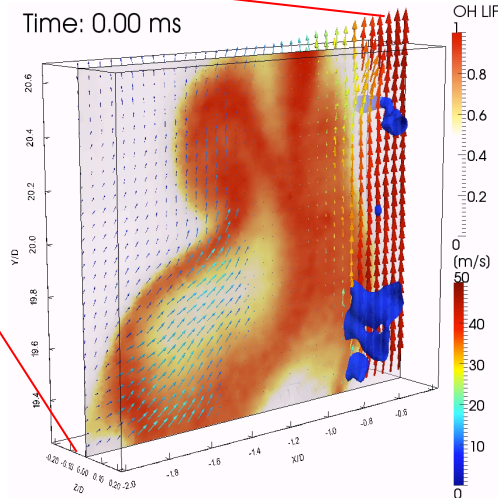
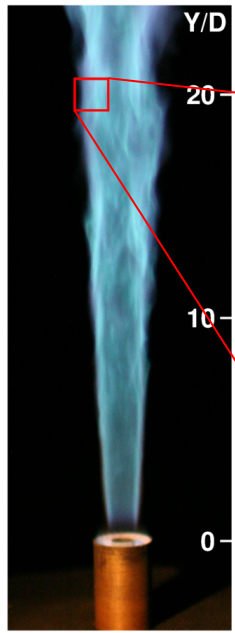

heat release rate



strain rate ↔ vorticity

Premixed flame with high dilatation, low mean shear

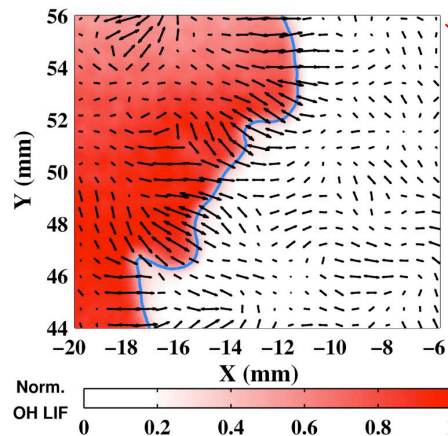
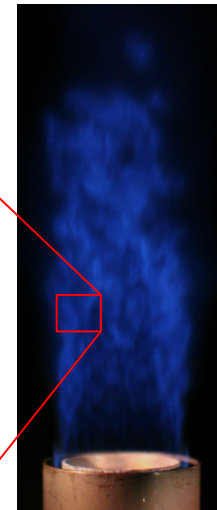

Tomographic PIV and OH PLIF at 10 kHz

Time Evolution of Strain Rate Induced Extinction

Tomographic PIV and OH PLIF at 10 kHz

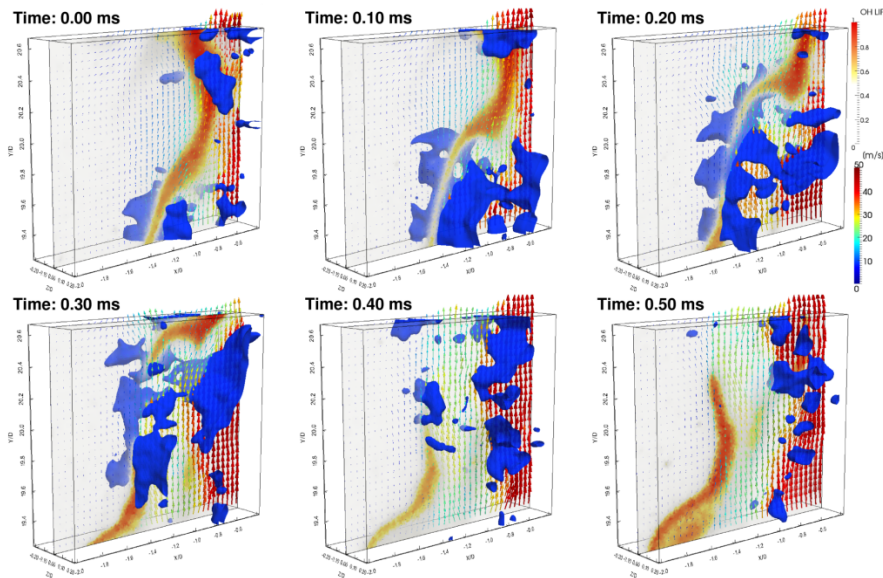

Blue isosurfaces: $s_3 = -15,000 \text{ s}^{-1}$

Steady laminar extinction limit: 817 s^{-1} (Zhou); 933 s^{-1} (Kaiser)

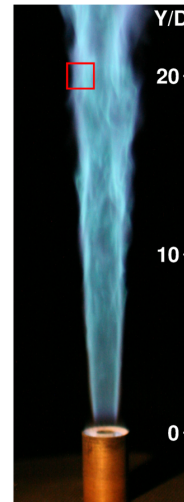

DME/air
Re=29,300

- High strain rate events are rare
- Time history of interaction is critical
- Preferred orientation of principal extensive strain rate in the shear layer of jets and jet flames

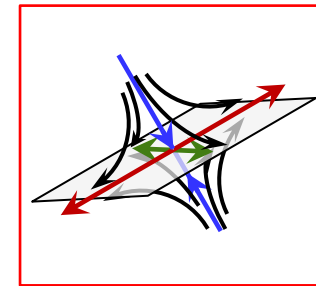

$s_1 > s_2 > s_3$
extensive int compressive

Partially Premixed CH₄/Air Jet Flames with Different Amounts of Extinction

10 kHz OH LIF Imaging

Increasing Heat Release

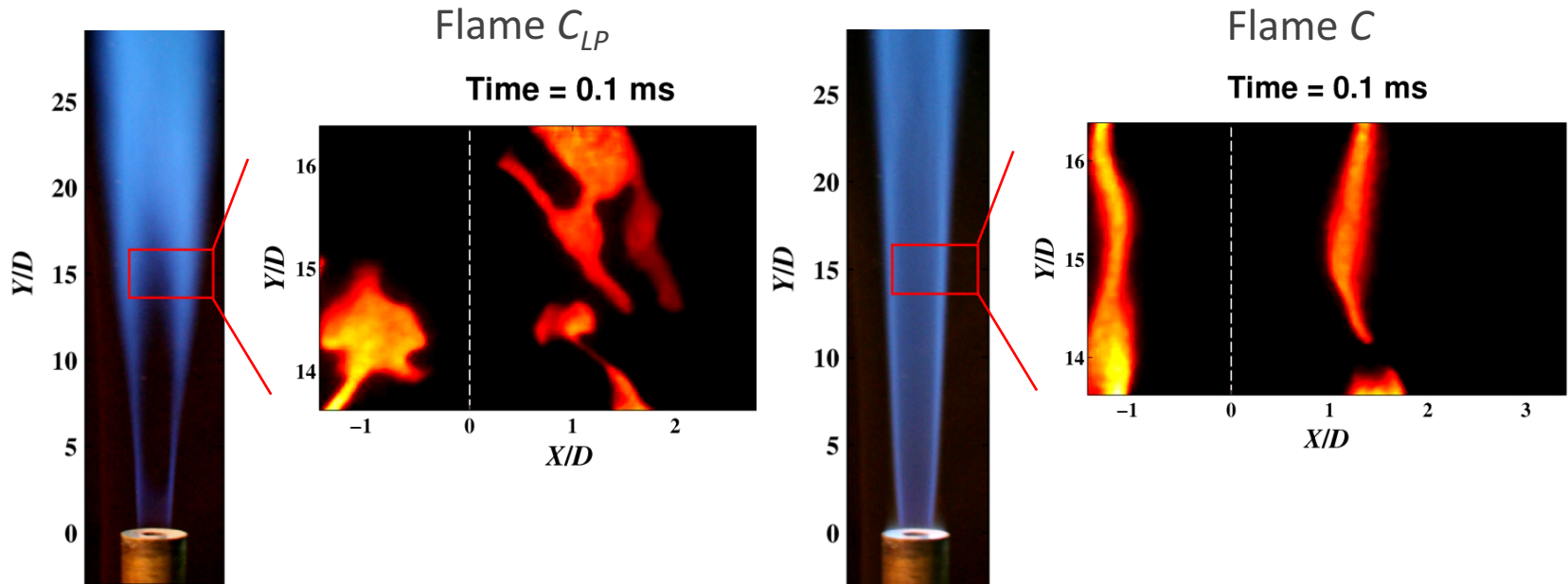

Summary of flow conditions.

Cases	ϕ_{jet}	Re_{jet}	V_{jet} (m/s)	V_{Pilot} (m/s)
Air	0.0	13500	27.5	0.0
C_{LP}	6.0	13000	27.5	1.8
C	6.0	13000	27.5	6.8

Partially Premixed CH₄/Air Jet Flames with Different Amounts of Extinction

10 kHz OH LIF Imaging

Increasing Heat Release

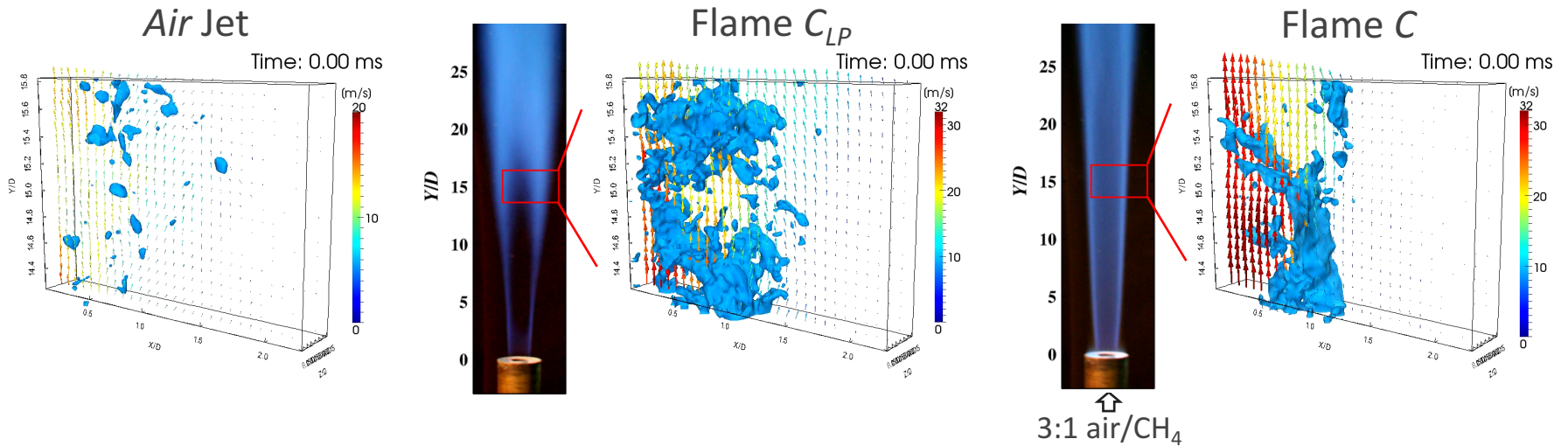

Isosurfaces: $|s_{\text{thrs}}| = 7,000 \text{ s}^{-1}$

$$|s| = (s_1^2 + s_2^2 + s_3^2)^{1/2}$$

- Bursts of large strain rate structures
- Air Jet: small fragmented structures throughout jet
- Flame C: large elongated structures concentrated near reaction zone
- Flame C_{LP}: localized extinction → intermittent features of both non-reacting and reacting flows

Enhanced Coupling of Strain Rate and Vorticity

Increasing Heat Release



Air Jet

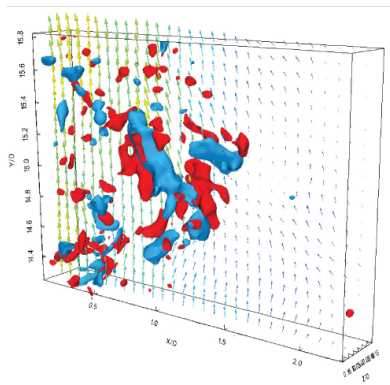

Flame C_{LP}

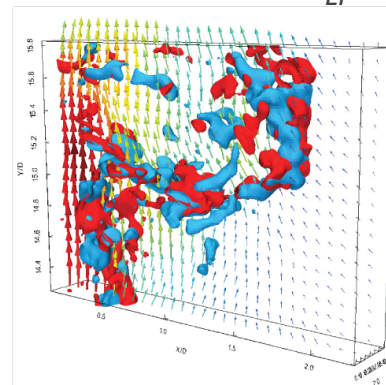

Flame C

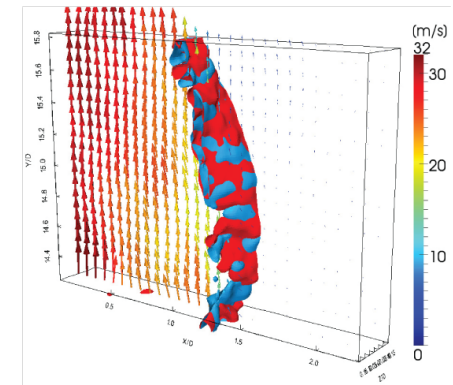

Strain Rate Isosurfaces
Vorticity Isosurfaces

Preferential Vorticity Alignment with Extensive Strain Increases Vorticity Production

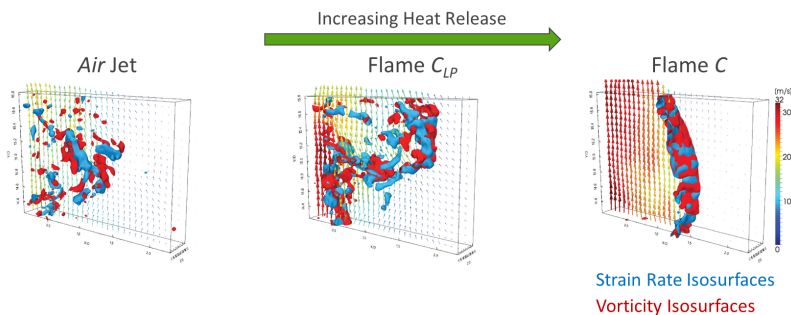
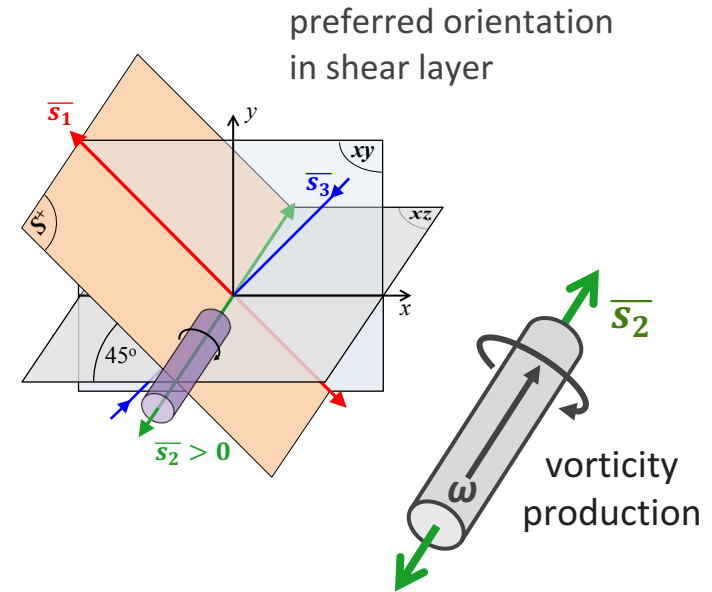
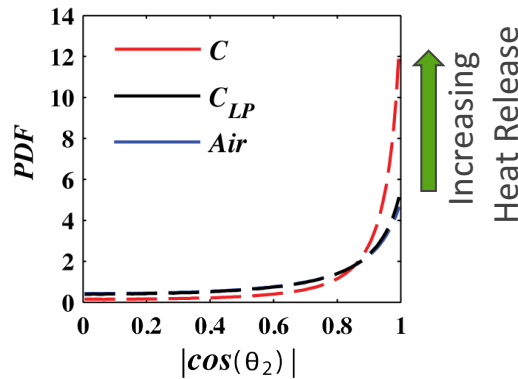
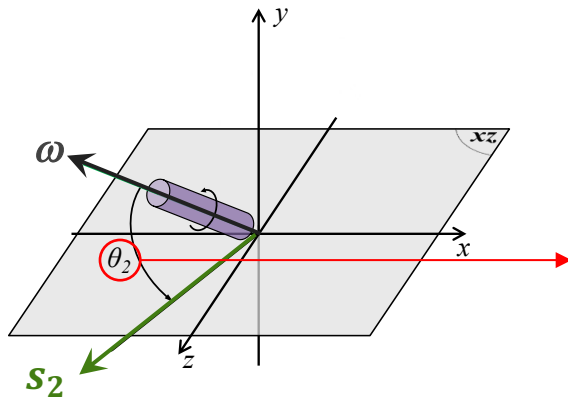

- Heat release induces alignment of vorticity and s_2 strain
- Large vorticity preferentially aligned with mean extensive $\overline{s_2}$ strain

Premixed Flame Flame Front and Strain Rate Analysis

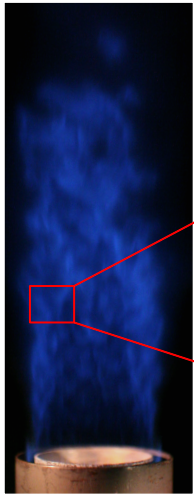

Flame front
contour

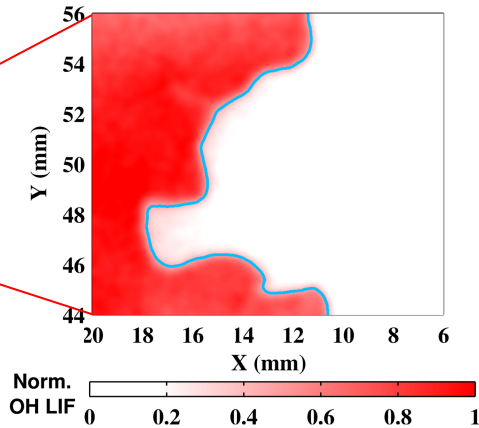

Flame front normal

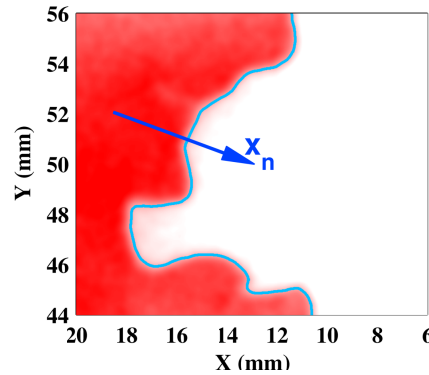

Strain rate
eigenvectors

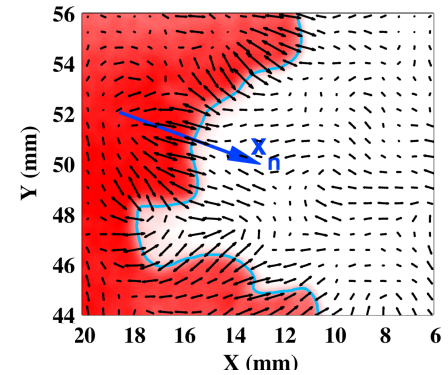

Strain-rate statistics analyzed from 5,000 single-shot TPIV measurements

Premixed Flame

Effect of Dilatation on Strain Rate Alignment

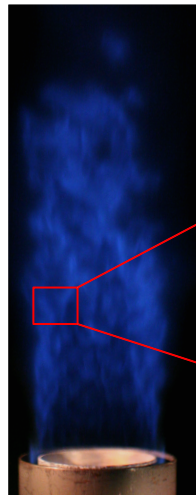

Projection of extensive strain (s_1) onto plane of OH-LIF measurement

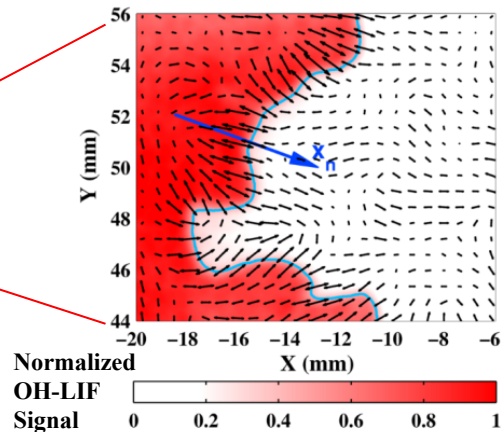

Probability of extensive strain (s_1) alignment towards flame-front normal direction

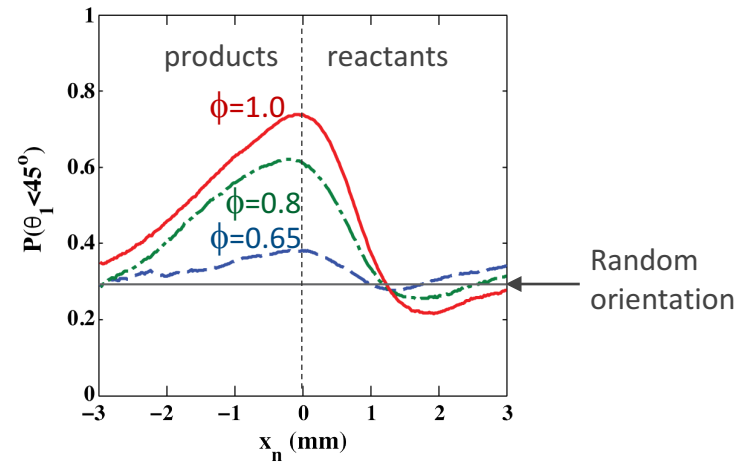

ϕ	τ	S_L (m/s)	u'/S_L	Da_t
0.65	4.8	0.15	4.1	1.7
0.80	5.8	0.24	2.6	3.0
1.00	6.5	0.34	1.8	5.1

$$\tau = (T_b - T_u) / T_u$$

$$Da_t = (l/u') / (l_F/S_L)$$

- Extensive strain rate preferentially aligned with flame-front normal
- Localized to millimeter length scale
- Strongly dependent on turbulence-flame parameters

3-D Measurements of Flow Fields in Turbulent Flames

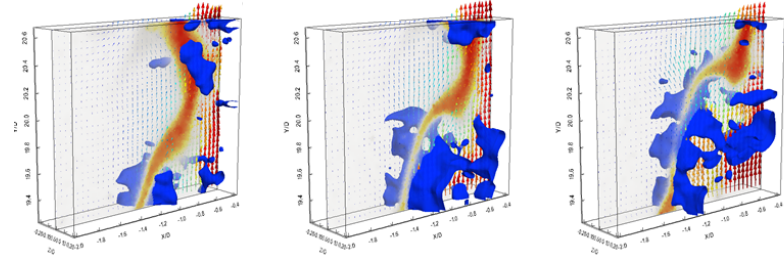

Coupling Tomo-PIV with Large Eddy Simulations

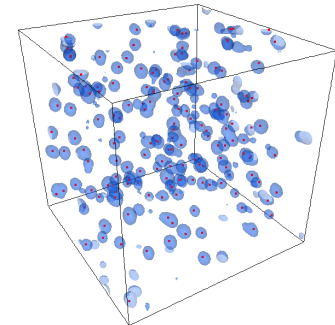
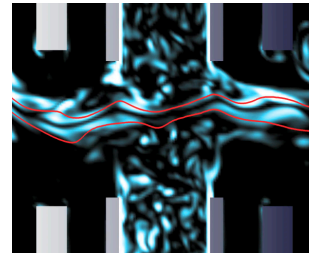

Dynamics of Transient Flows in Challenging Environments

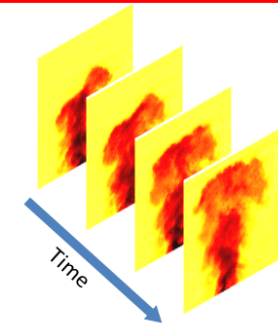
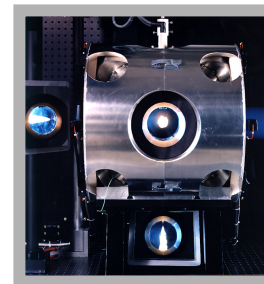

Coupling Experiments and Simulations

Requires detailed simulation of actual experimental configuration and sufficient run times for converged statistics

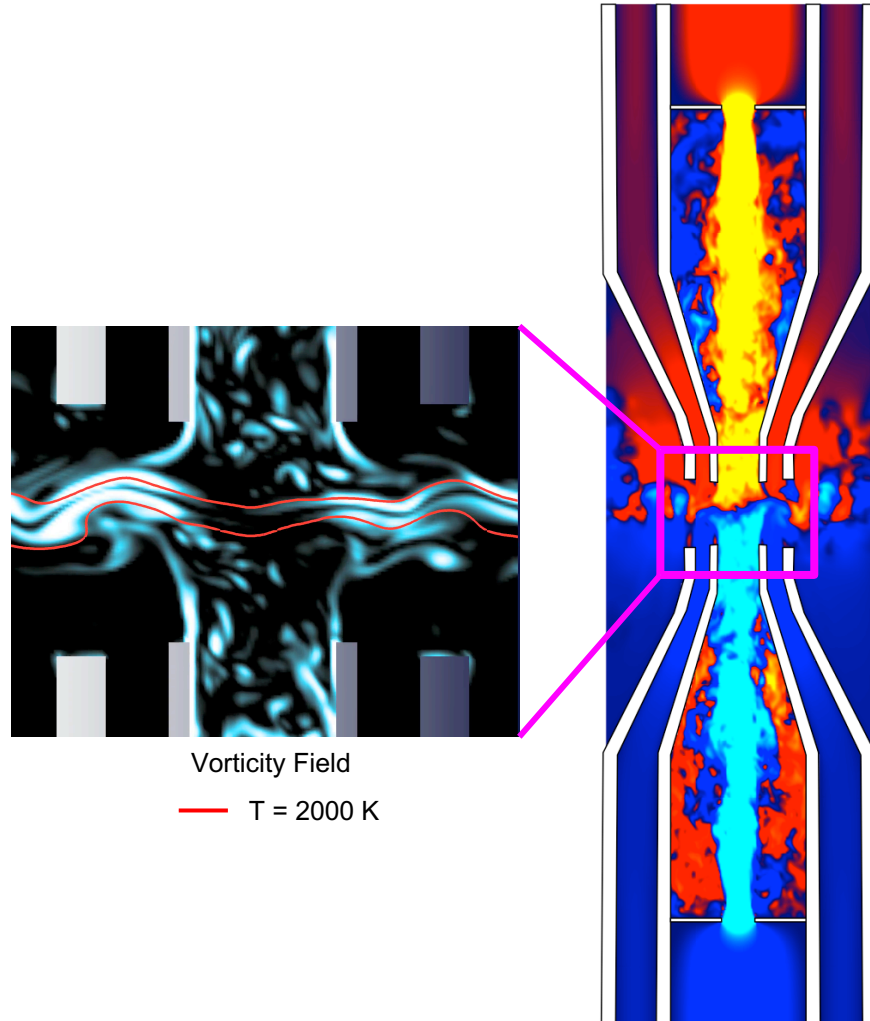
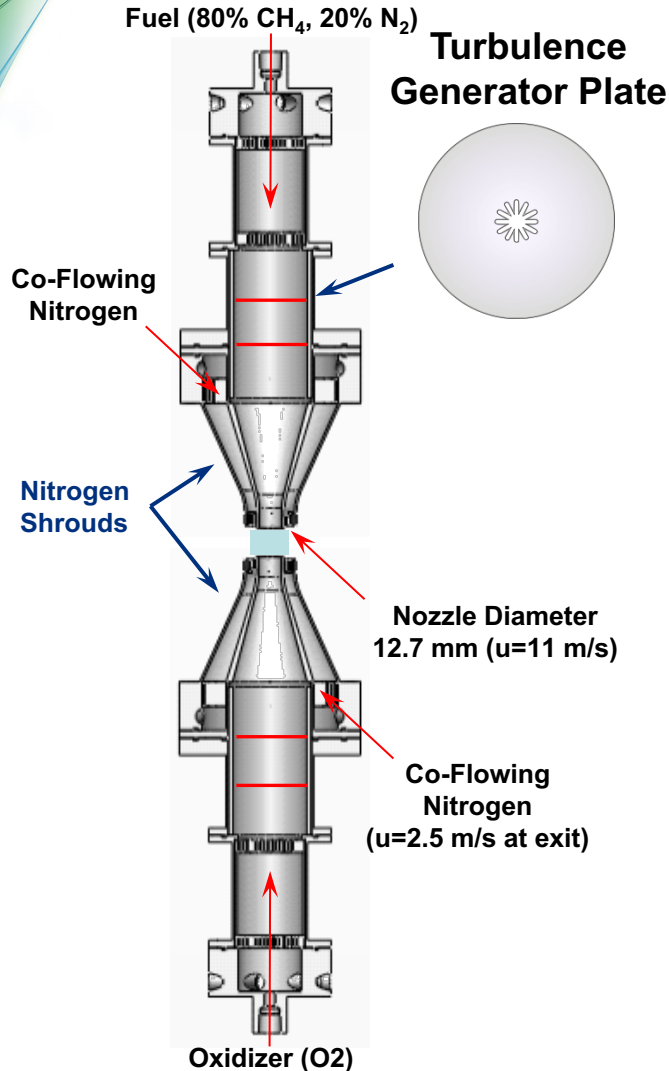



Theoretical-Numerical Framework

(RAPTOR: A general solver optimized for LES)

- Theoretical framework ... (**Comprehensive physics**)
 - Fully-coupled, compressible conservation equations
 - Real-fluid equation of state (high-pressure phenomena)
 - Detailed thermodynamics, transport and chemistry
 - Multiphase flow, spray
 - Dynamic SGS modeling (No Tuned Constants)
- Numerical framework ... (**High-quality numerics**)
 - Staggered finite-volume differencing (non-dissipative, discretely conservative)
 - Dual-time stepping with generalized preconditioning (all-Mach-number formulation)
 - Detailed treatment of geometry, wall phenomena, transient BC's
- Massively-parallel ... (**Highly-scalable**)
 - Demonstrated performance on full hierarchy of HPC platforms

Full LES Domain Simulates Internal Flow Through Turbulence Generator Plate

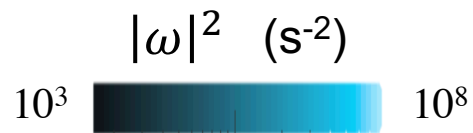
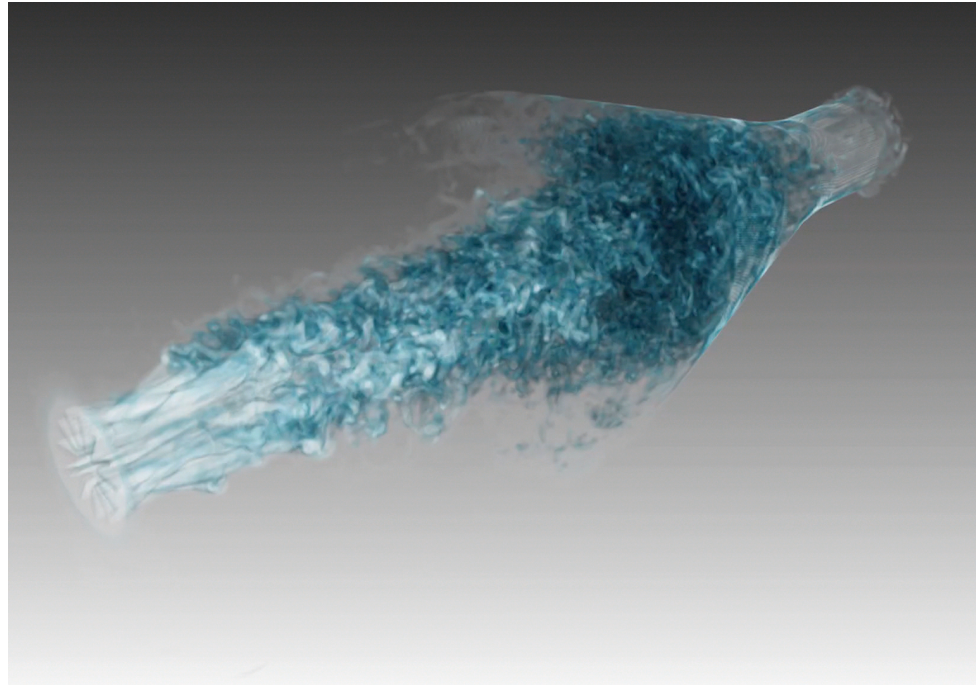

Parametric Studies of Tomo-PIV Uncertainty using Synthetic Particles in Counterflow

60 particles/mm³

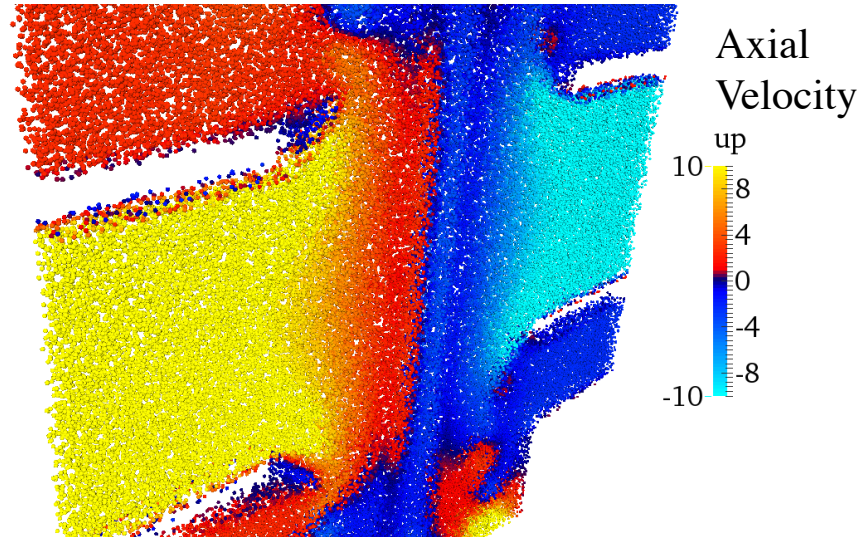

- Particles introduced after 10-20 flow-through times
- Aluminum oxide particles ($d = 0.3 \text{ } \mu\text{m}$)
- Trilinear interpolation used to calculate velocity of each particle
- LES cell size = $450 \text{ } \mu\text{m}$ (comparable to Tomo-PIV interrogation window)

Emulate Experimental Configuration with Synthetic Tomographic Projections

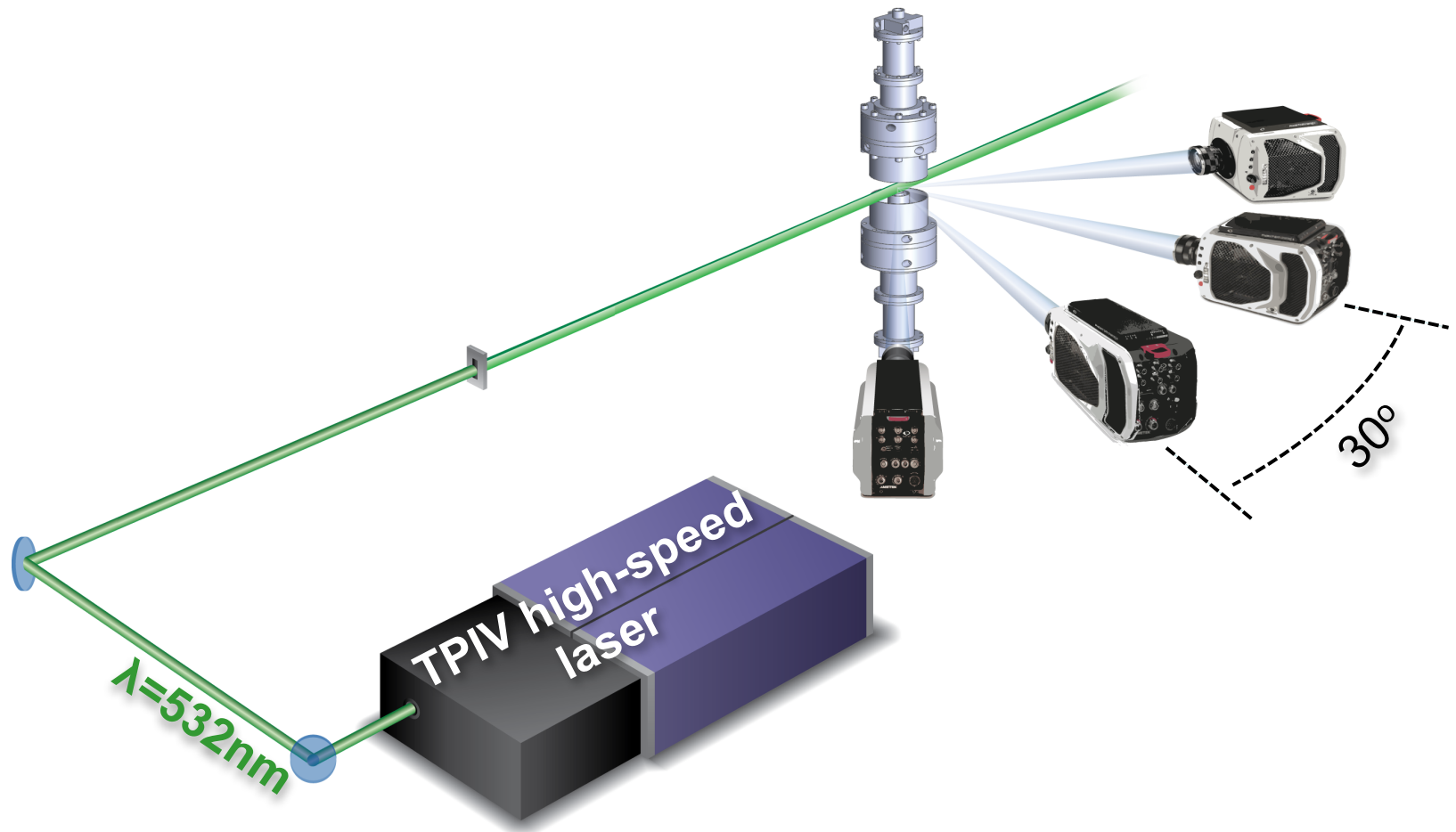

Subset of Reconstructed Particle Field

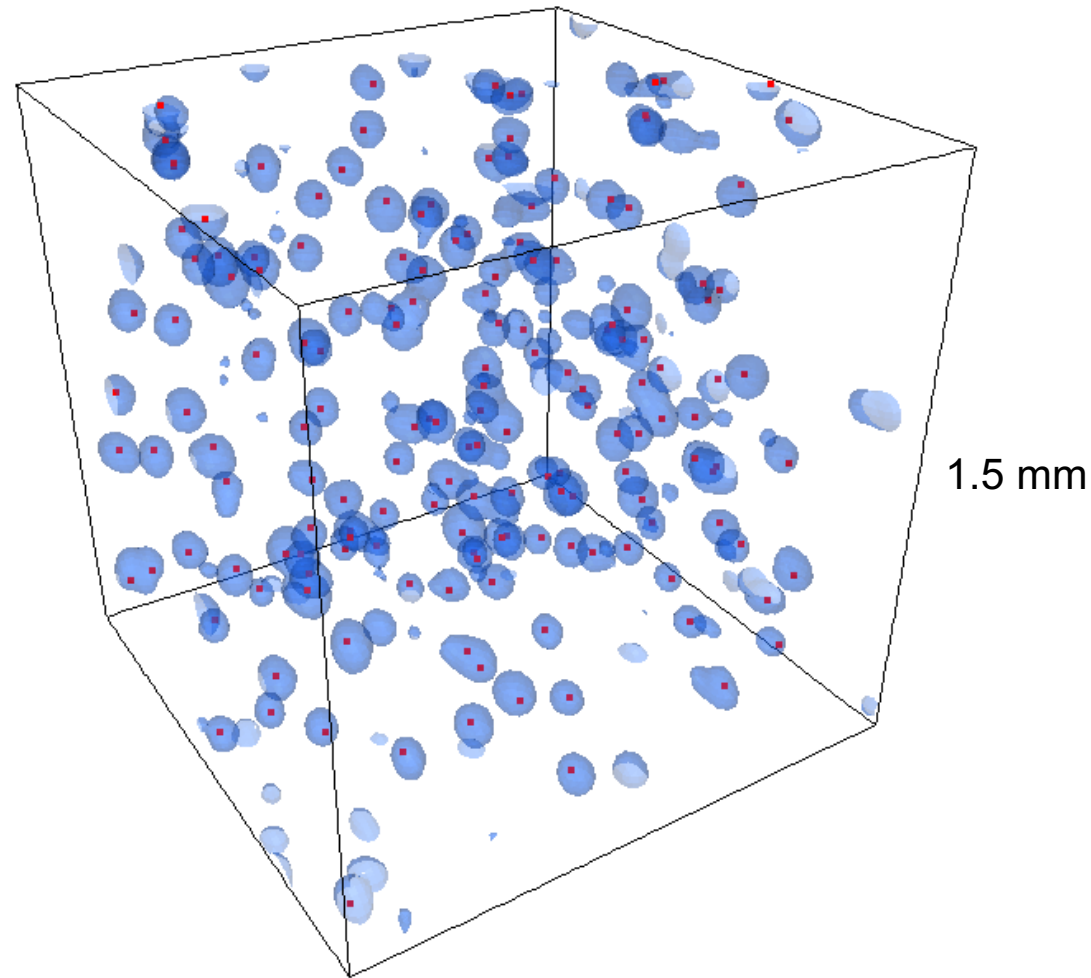

Red dots = actual particle locations from LES

Blue regions = tomographic reconstruction

Source of Artifacts in Tomo-PIV

● = Artifacts (“Ghost Particles”)

Laser beam
illumination
of particles

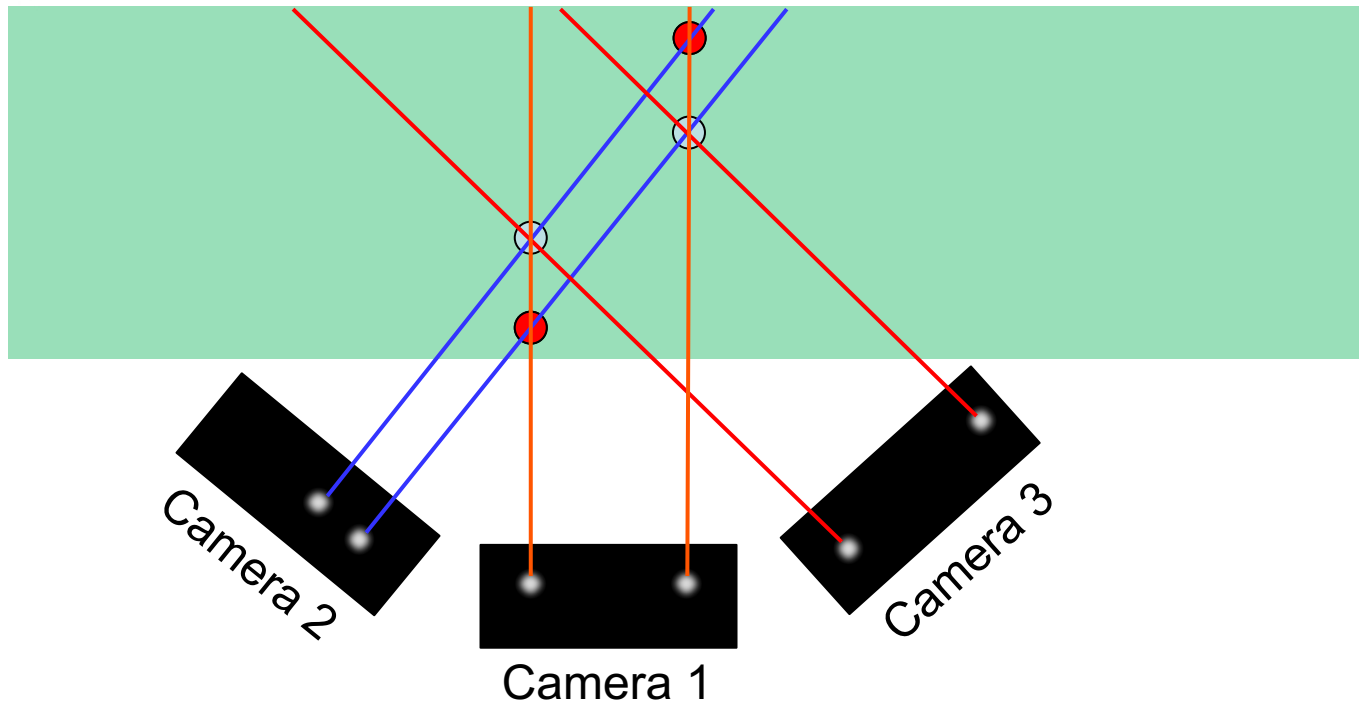

Parametric Studies of Uncertainty

Particle Number Density

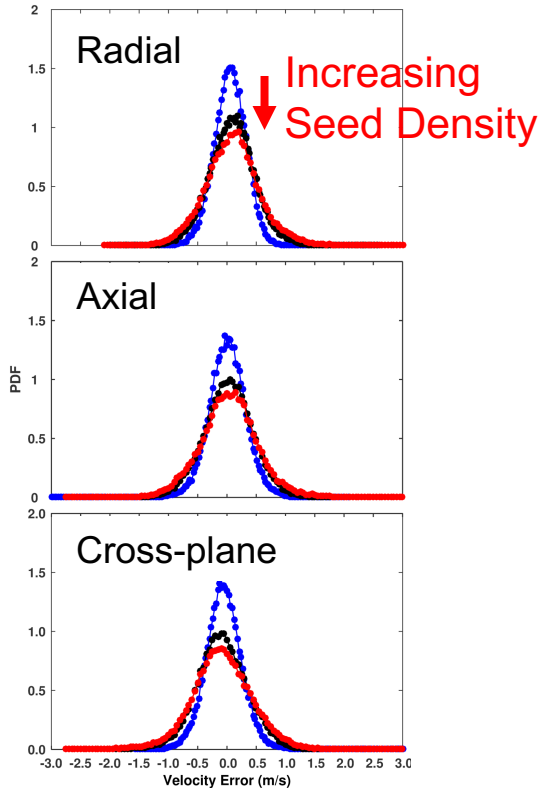

particles/mm³

- 60
- 120
- 180

Detector Noise

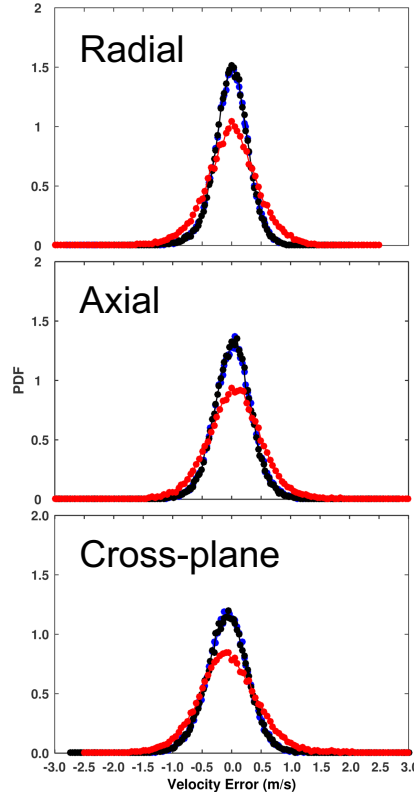

- Noiseless
- Camera Noise Added
- Noise x 10

Effect of Particle Number Density on Vorticity Magnitude

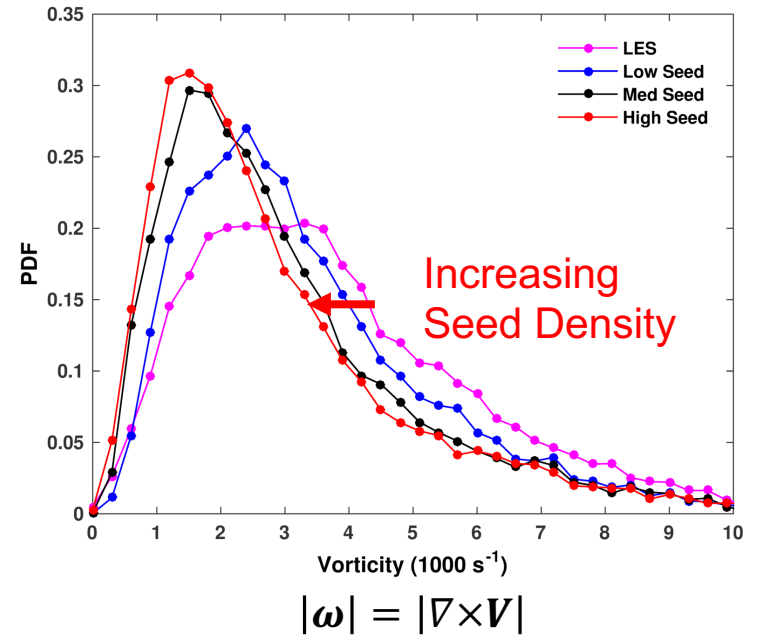



Summary

LES Evaluation of Tomographic PIV

- Parametric numerical studies to assess uncertainties and improve Tomo-PIV processing in reacting flows
- Enables testing of approaches for using time-correlated data
- LES code can simulate Tomo-PIV measurements using varying resolution
- Ultimately, evaluate multi-dimensional conditional statistics in experiments and simulations to study feedback between chemical reactions and turbulence accounting for differences in spatio-temporal averaging

Outline

3-D Measurements of Flow Fields in Turbulent Flames

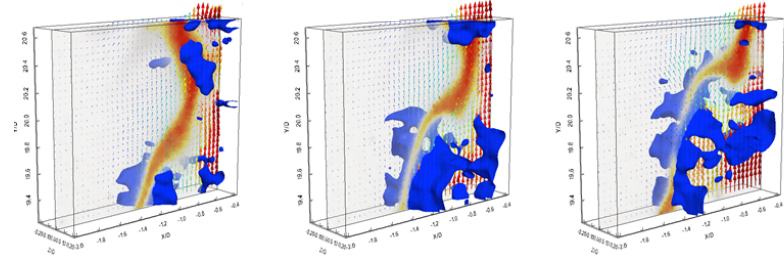

Coupling Tomo-PIV with Large Eddy Simulations

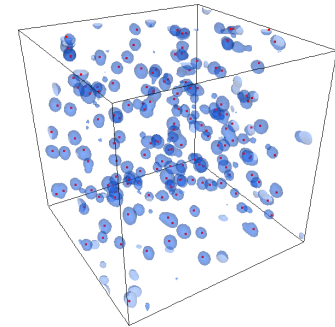
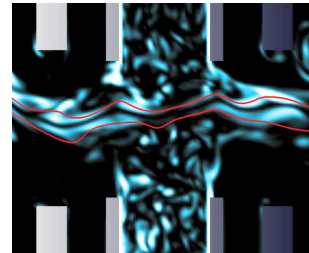

Dynamics of Transient Flows in Challenging Environments

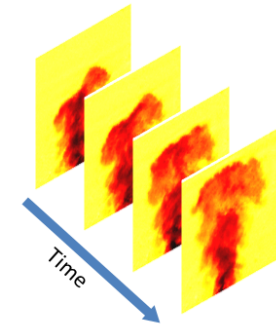
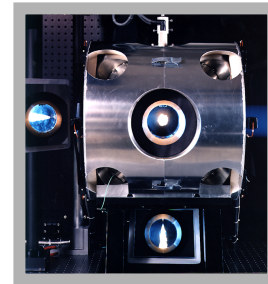



Diagnostics in Challenging Environments

- Limited optical access
- Measurements through windows and near surfaces
- High-speed flows, small length scales
- Interferences (laser-generated, background), optical density
- Beam steering
- Pressure effects on spectroscopy
- Multi-phase flows

Burst-Mode Lasers Well-Suited for Imaging High-Speed Transient Flows

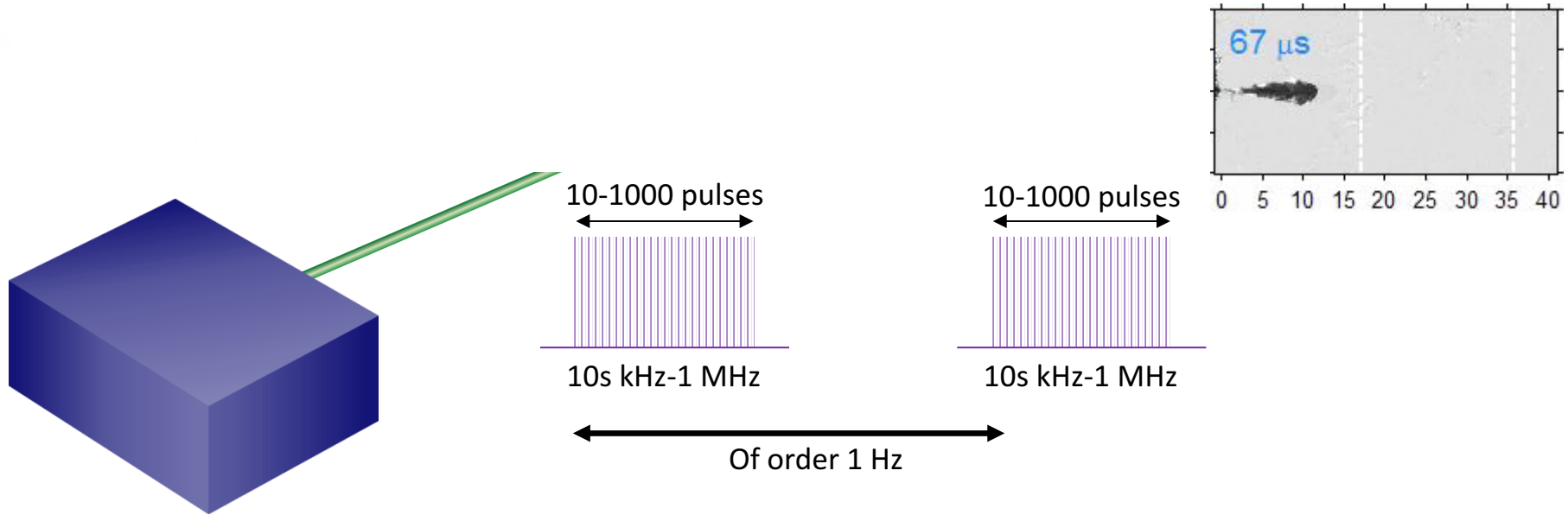

Balance pulse energy and repetition rate requirements with laser thermal load, optical damage thresholds

Diode pumping offers improved efficiency

Fuel spray mixing is important to efficiency

Issues in direct-injection spray

- Temperature non-uniformities
- Mixture/flow preparation near spark
- Fuel films on piston/injector, rich pockets
- Control of stratification/residence time to stage heat release

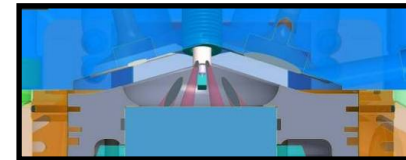
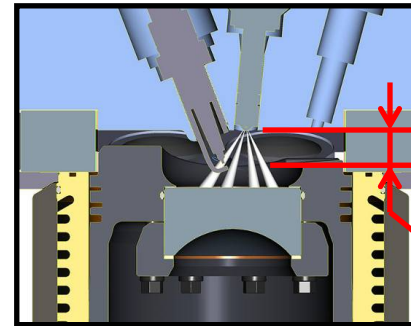

8-hole, gasoline
80° total angle
~15mm

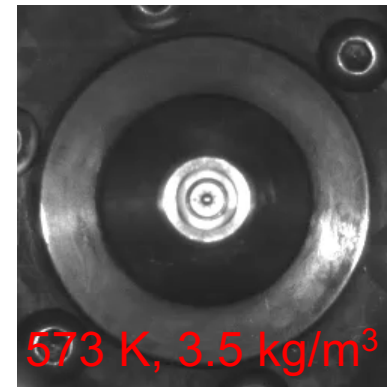

573 K, 3.5 kg/m³

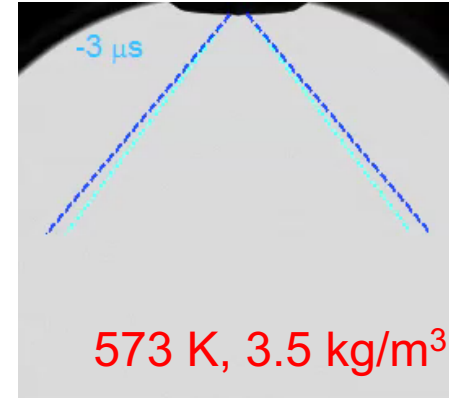

573 K, 3.5 kg/m³

Plume collapse limits mixing of fuel with air and is not well predicted.

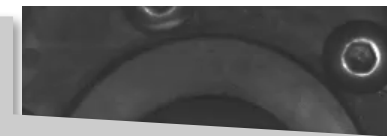

800 K, 9 kg/m³

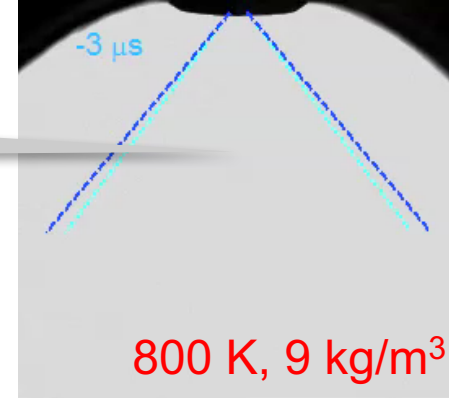

800 K, 9 kg/m³

Spray "G" Target Case in ECN

Velocity Measurements in Central Region of Iso-octane Plumes Using PIV

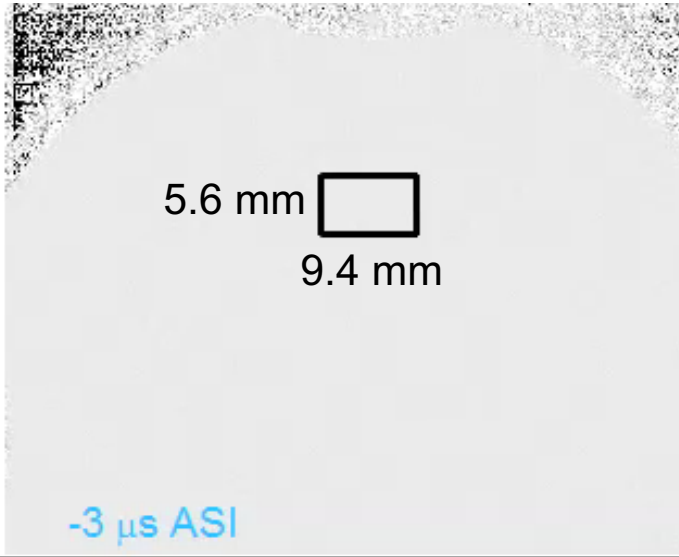

Measurement plane between plumes to probe central region

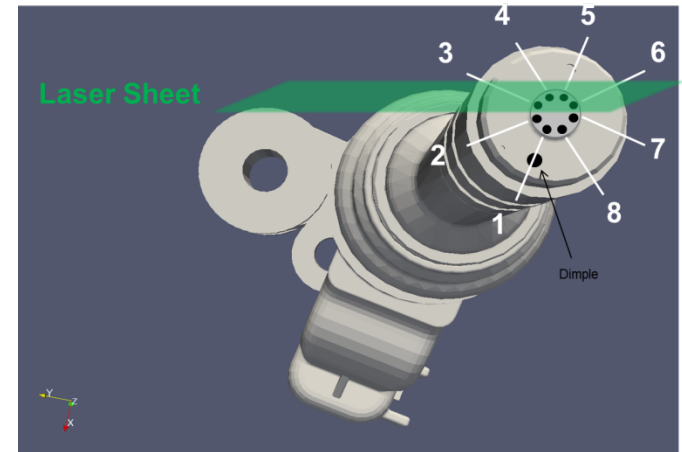

Pulse-burst laser system
 100 kHz pulse pairs
 500 pulse pairs (5 ms burst)
 15 mJ/pulse, $\lambda = 532$ nm

<u>Ambient Gas</u>	<u>Fuel</u>
573 K	363 K
6 bar	200 bar
3.5 kg/m ³	iso-octane
0% O ₂	170 μ m nozzle

Plumes remain separate during injection but then merge at the end of injection

Time Evolution of Velocity Between Plumes

15mm 573K 3.5kg/m³

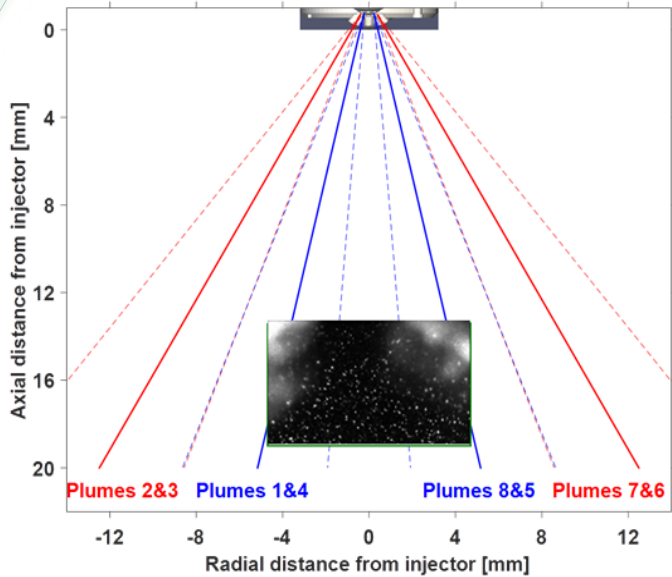

PIV improved by dynamic background subtraction

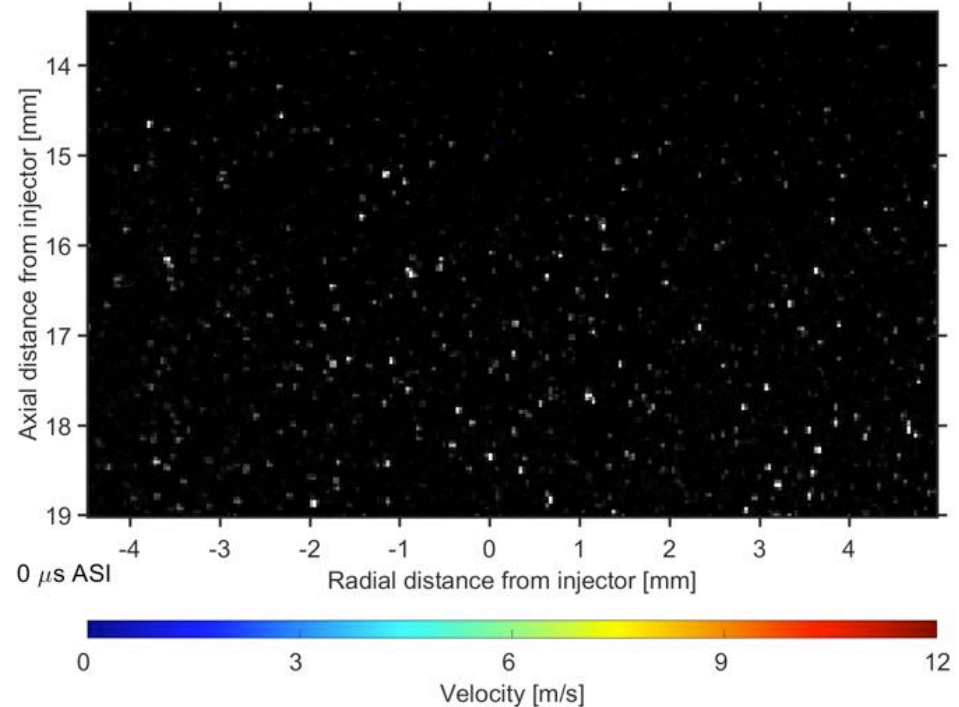

Temporal filtering schemes useful
For challenging environments

Particle displacement calculation
using sliding sum of correlations

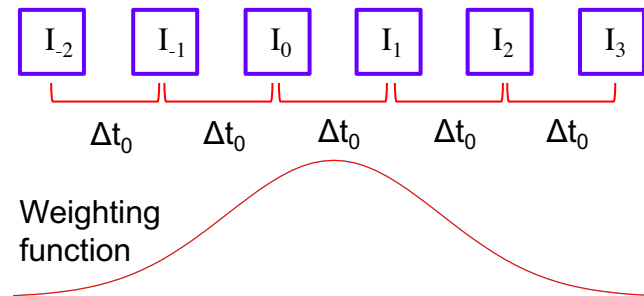

Adaptive filter schemes: Sciacchitano, Scarano, Wieneke, *Exp. Fluids* 53 (2012)

Temporal Filtering of PIV Data to Improve Velocity Measurements in Challenging Environments

- The Sliding Sum of Correlations gave the most accurate vector fields
 - The correlations between neighboring frames was calculated
 - Particle displacement vectors calculated by summing the correlations using Gaussian weighting

Sequence of Particle Images from High Speed PIV

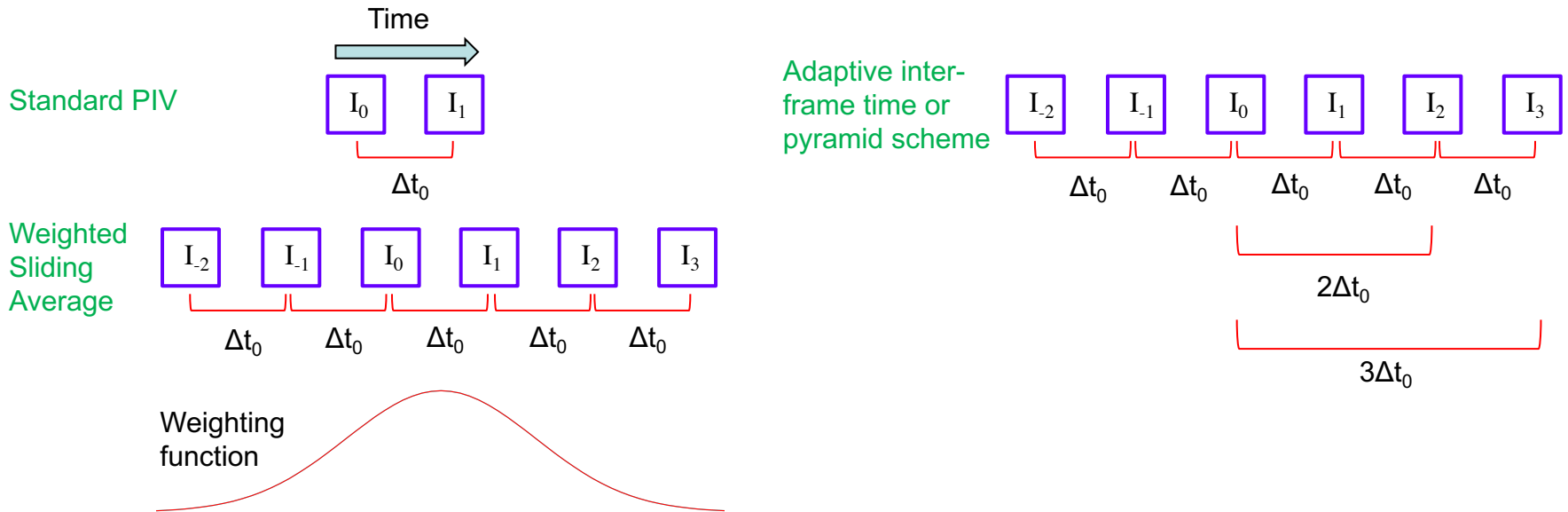

Time Evolution of Velocity Between Plumes

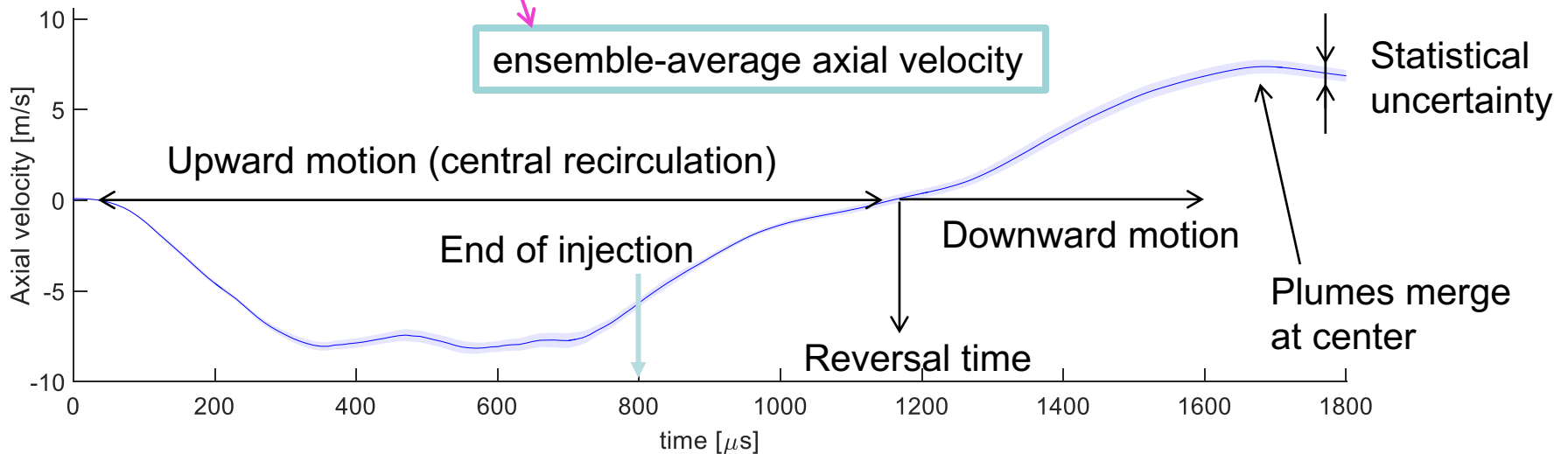
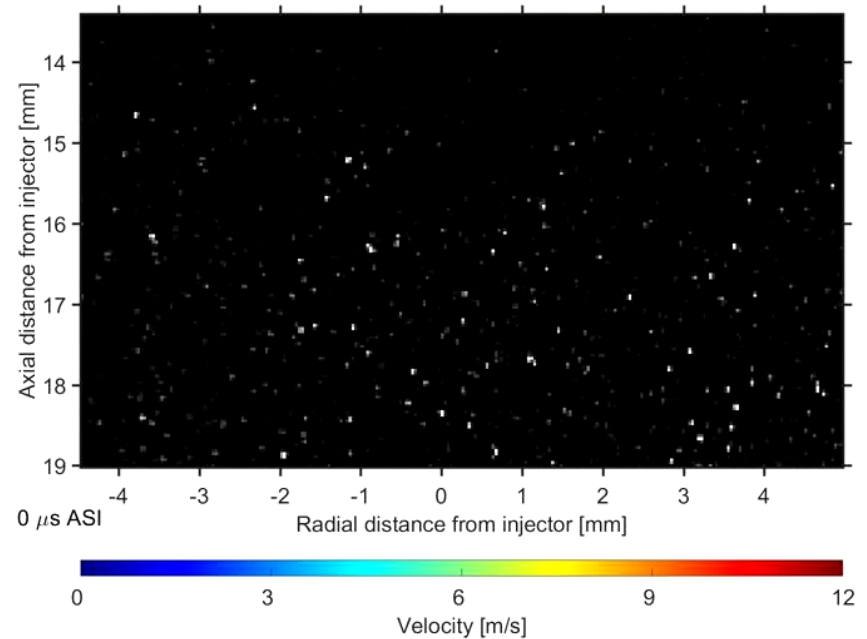
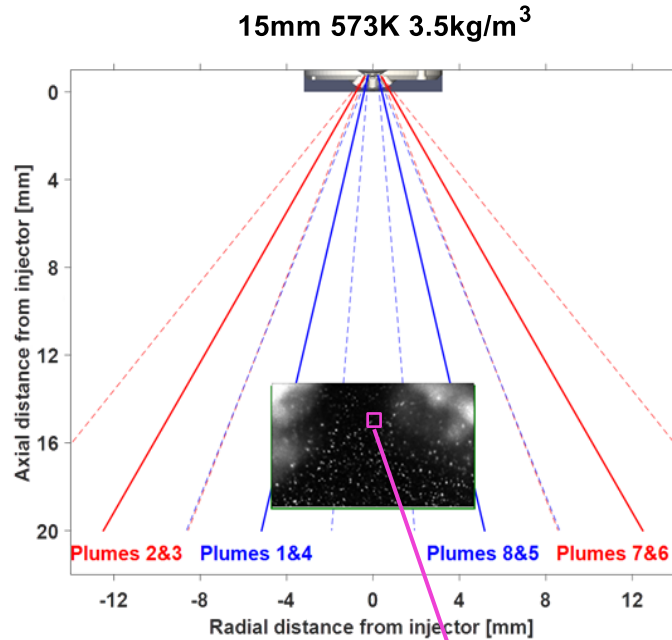



Summary

Imaging of High-Pressure Fuel Injection with Pulse-Burst Laser

- PIV of iso-octane mixing in gasoline injector
- Captured flow reversal leading to plume collapse
- Ongoing investigation of different injection conditions and further planar imaging diagnostics

3-D Measurements of Flow Fields in Turbulent Flames

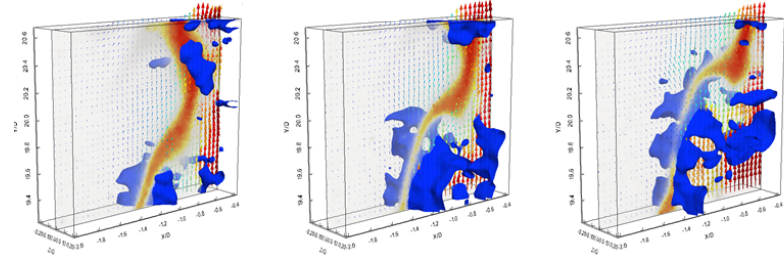

Coupling Tomo-PIV with Large Eddy Simulations

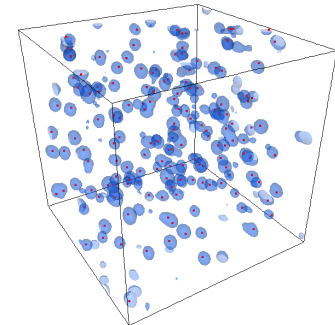
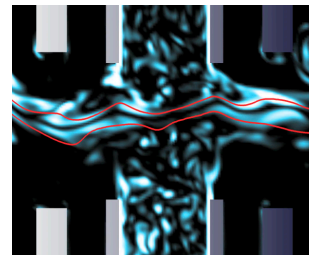

Dynamics of Transient Flows in Challenging Environments

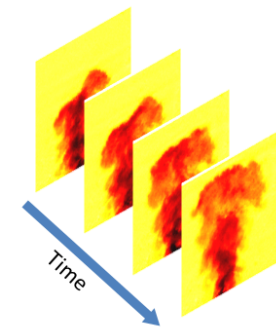
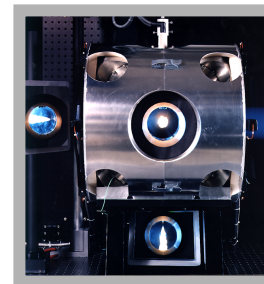



Acknowledgements

Sandia National Laboratories

Scott Bisson

Brian Patterson

Erxiong Huang

*Division of Chemical Sciences, Geosciences, and Biosciences
Office of Basic Energy Sciences, U.S. Department of Energy*

Office of Vehicle Technologies, U.S. Department of Energy

Sandia Laboratory Directed Research and Development Program





Themes in Laser Imaging Diagnostics for Understanding Turbulence-Flame Interactions

- **Advances in dimensionality of diagnostics**
 - Dynamics & structure of turbulence-chemistry interactions
 - velocity/species/temperature: 3D and 4D (spatio-temporal) measurements
 - Thermochemical state
 - temperature/species: single-point → 1D → 2D measurements
- **Expanding capabilities in challenging environments**
 - Approaches for treating interferences, imaging artifacts
 - Tailoring diagnostics to problem of interest
- **Opportunities for coupling experiments and simulations**
 - Approaches for statistical comparisons of multi-dimensional, multi-parameter datasets
 - Development and optimization of experimental and simulation methods

Outline

Advances in Temperature & Species Measurements

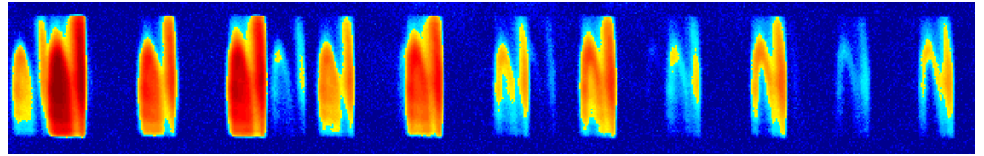

3-D Measurements of Flow Fields in Turbulent Flames

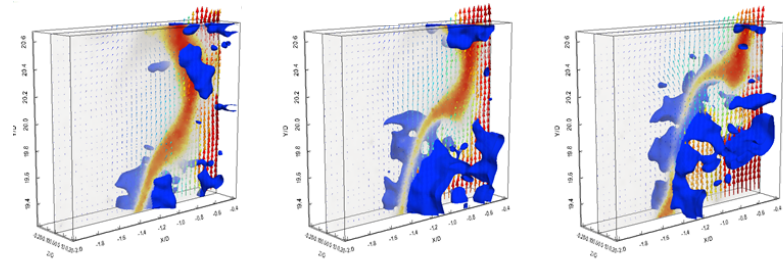

Coupling Tomo-PIV with Large Eddy Simulations

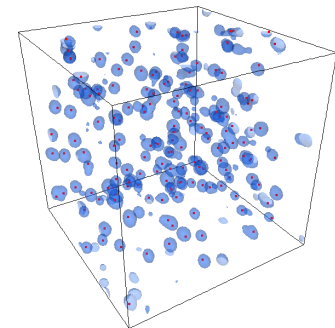
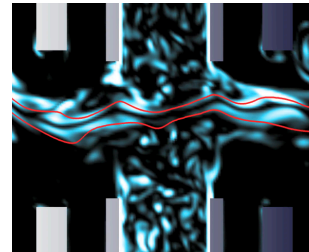

Dynamics of Transient Flows in Challenging Environments

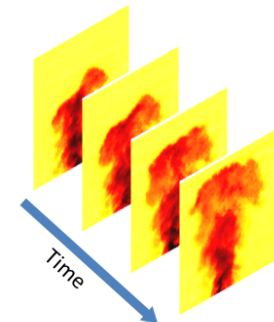
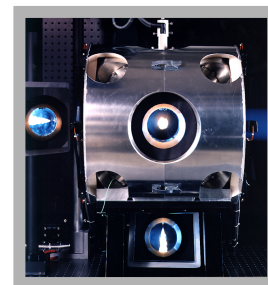



Spatial and Temporal Resolution

- **Lengthscales**

- Probe volume dimensions: 16.5 x 12.3 x 2.5 mm³
- Spatial resolution: $\lambda_m = 413 \mu\text{m}$ (width of interrogation volume)
- Integral lengthscale: $\delta \sim 16 \text{ mm}$ (full width at half max. of mean axial velocity)
- Kolmogorov scale: $\eta \sim 50 \mu\text{m}$ (*Air jet*) (Ref.: Frank and Kaiser, 2010)
 $\eta \sim 120 \mu\text{m}$ (*Flame C*) (Ref.: Wang et al., 2007)

- **Timescales**

- Measurement resolution: $\Delta t_m = 0.1 \text{ ms}$ (10 kHz)
- Mean flow residence time: $\tau_{probe} \sim$ from 0.6 ms (*Flame C*) to 1.3 ms (*Air jet*)
- λ_m -eddy turnover time: $\tau(\lambda_m) = (\lambda_m^2 \cdot \delta)^{1/3} / u' \sim 0.7 \text{ ms}$

- $\frac{\tau_{probe}}{\Delta t_m} \sim 6-13$ (large scale dynamics resolved)

- $\frac{\Delta t_m}{\tau(\lambda_m)} \sim 0.15 < 0.5$ (Nyquist criterion satisfied)

- $\frac{\tau_{probe}}{\tau(\lambda_m)} \sim 1-2$ (λ_m -eddy turnover approximately completed in probe volume)



Issues with Tomographic Reconstruction

- Particle seed density
 - Balance seeding density for reactant/product regions
 - Tradeoff spatial resolution and probe volume
- Calibration of imaging system
 - Multiple target images + self-calibration technique
- Reconstruction algorithm
- Artifacts
 - Distortions in reconstructed particle images
 - “Ghost particles”

Effect of PIV Resolution on Measured Strain Rate

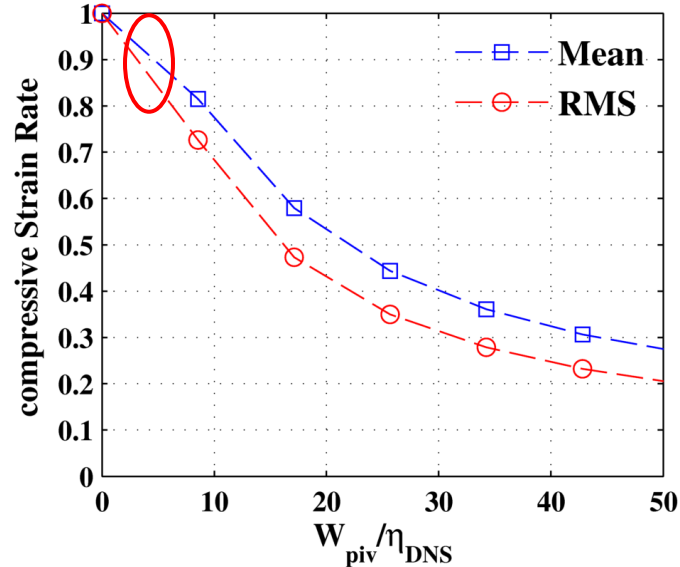

- Apply PIV windowing to DNS of forced isotropic turbulence¹
- 10% average under-estimation of strain rate for $W_{piv} = 5 \eta$

¹DNS results from Johns Hopkins Turbulence Databases (turbulence.pha.jhu.edu)

Measurement Uncertainty

Standard deviations

	Reactants	Flame
u	3 cm/s	7 cm/s
v (axial)	8 cm/s	12 cm/s
w	4 cm/s	8 cm/s

	Reactants	Flame
s_1	120 s ⁻¹	160 s ⁻¹
s_3	160 s ⁻¹	250 s ⁻¹
$\nabla \cdot v$	350 s ⁻¹	480 s ⁻¹

Measurements in a laminar partially-premixed DME/Air opposed jet flame

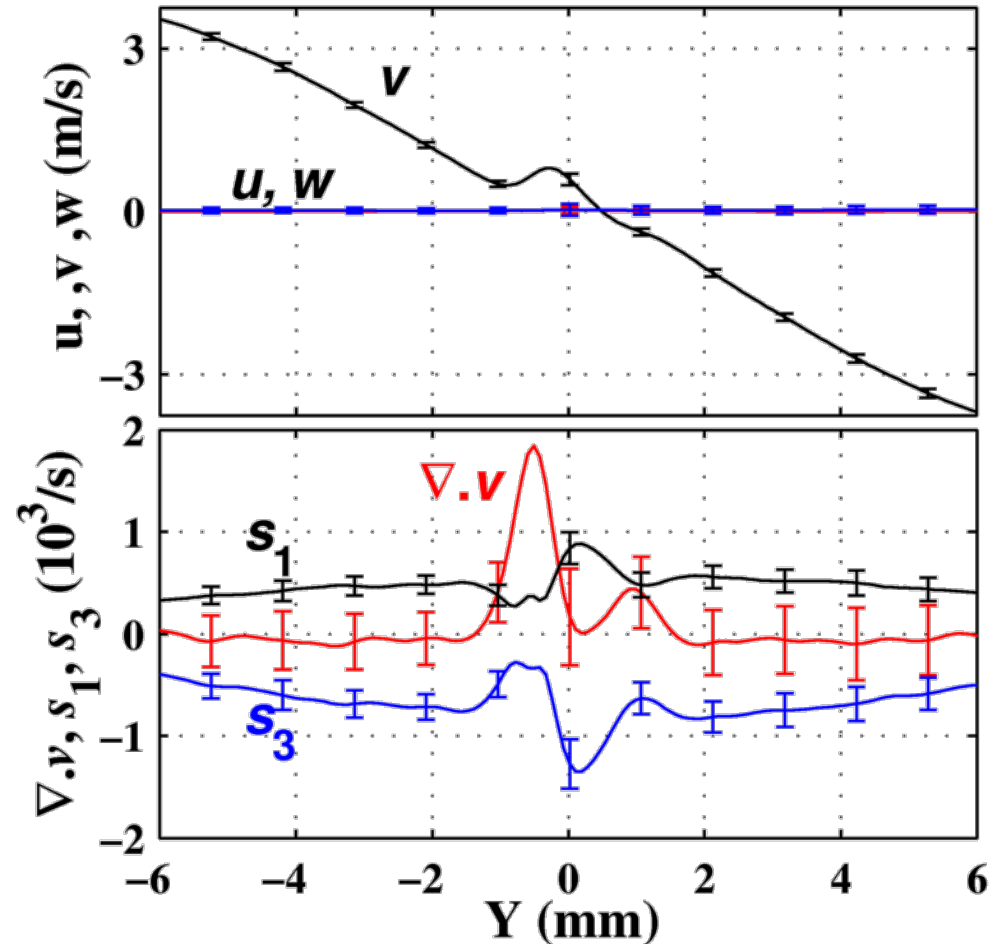

Error bars = +/- standard deviation

Advances in Imaging Diagnostics Applied to High-Pressure Fuel Injection

Previous Imaging Capabilities

Line-of-sight Measurements

- Limited diagnostic techniques
- Difficult to interpret

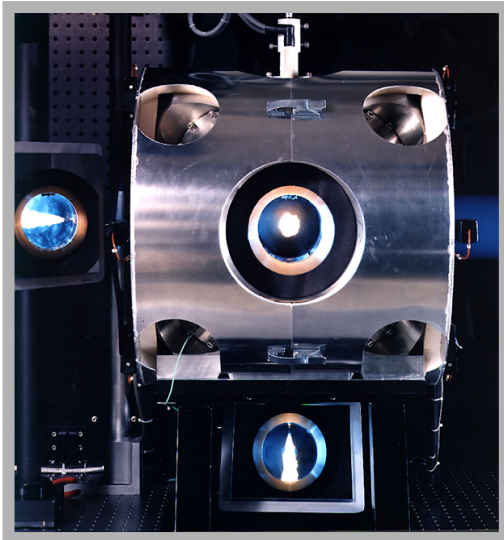

High-Pressure Fuel Injection for IC Engines

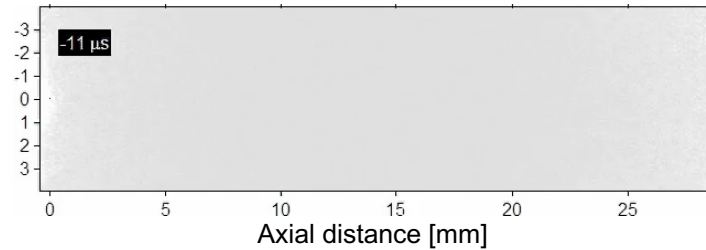

Single-shot planar imaging

- Missing insight into dynamics

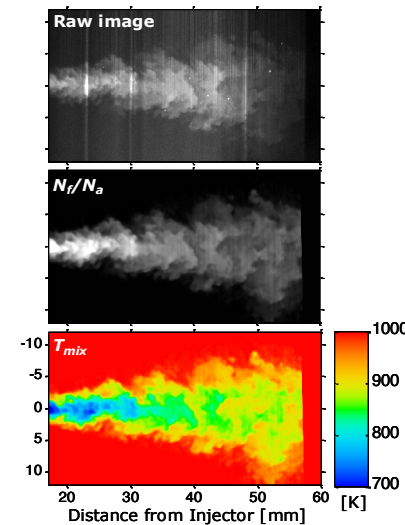



Diesel Ignition/Combustion Linked to Transient Mixing

Diesel "Spray A" conditions

Ambient Gas

900 K

60 bar

15% O₂

Fuel

373 K

1500 bar

n-dodecane

90 μm nozzle

150 kHz schlieren imaging

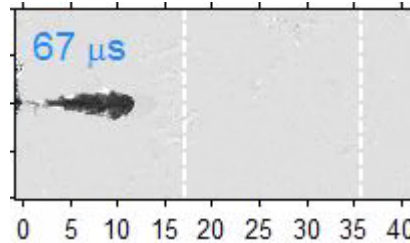

Schlieren

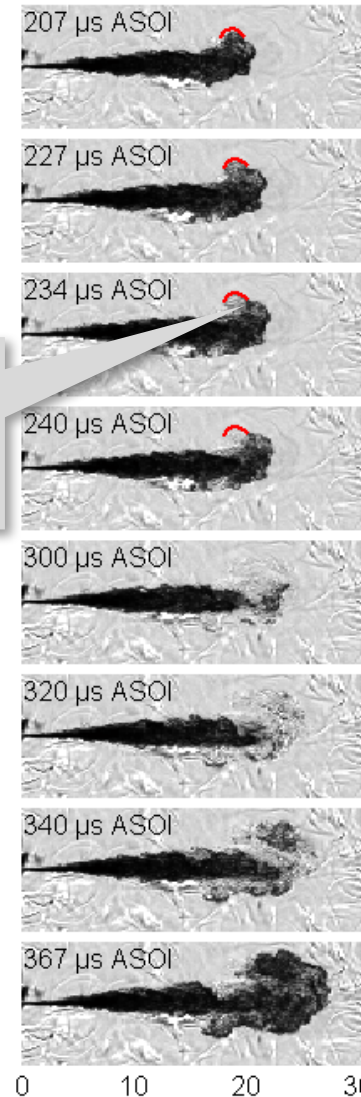

Distance from injector orifice [mm]

How does local mixture state evolve prior to autoignition?

- Cool flame initiates in
 - Schlieren "transparent" scale organization
 - Cool flame temperature close to 900 K
- High-temperature ignition occurs in the "head" region
 - Low-density (2000 K) zones appear again
 - Flame "lift-off" stabilizes at approx. 17 mm
- Accurate CFD modeling of ignition is needed

RANS

LES

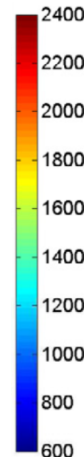
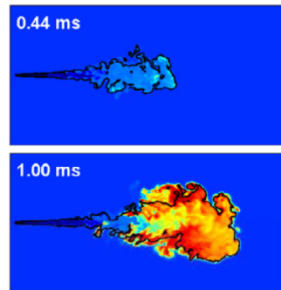
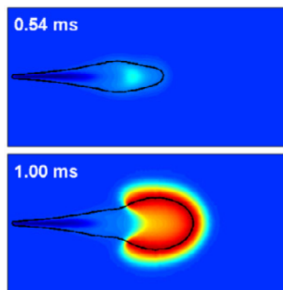

Pei et al.
Combust. Flame
162:4442 (2015)

Transient Evolution of Jet Shows Detailed Structural Flow Interactions

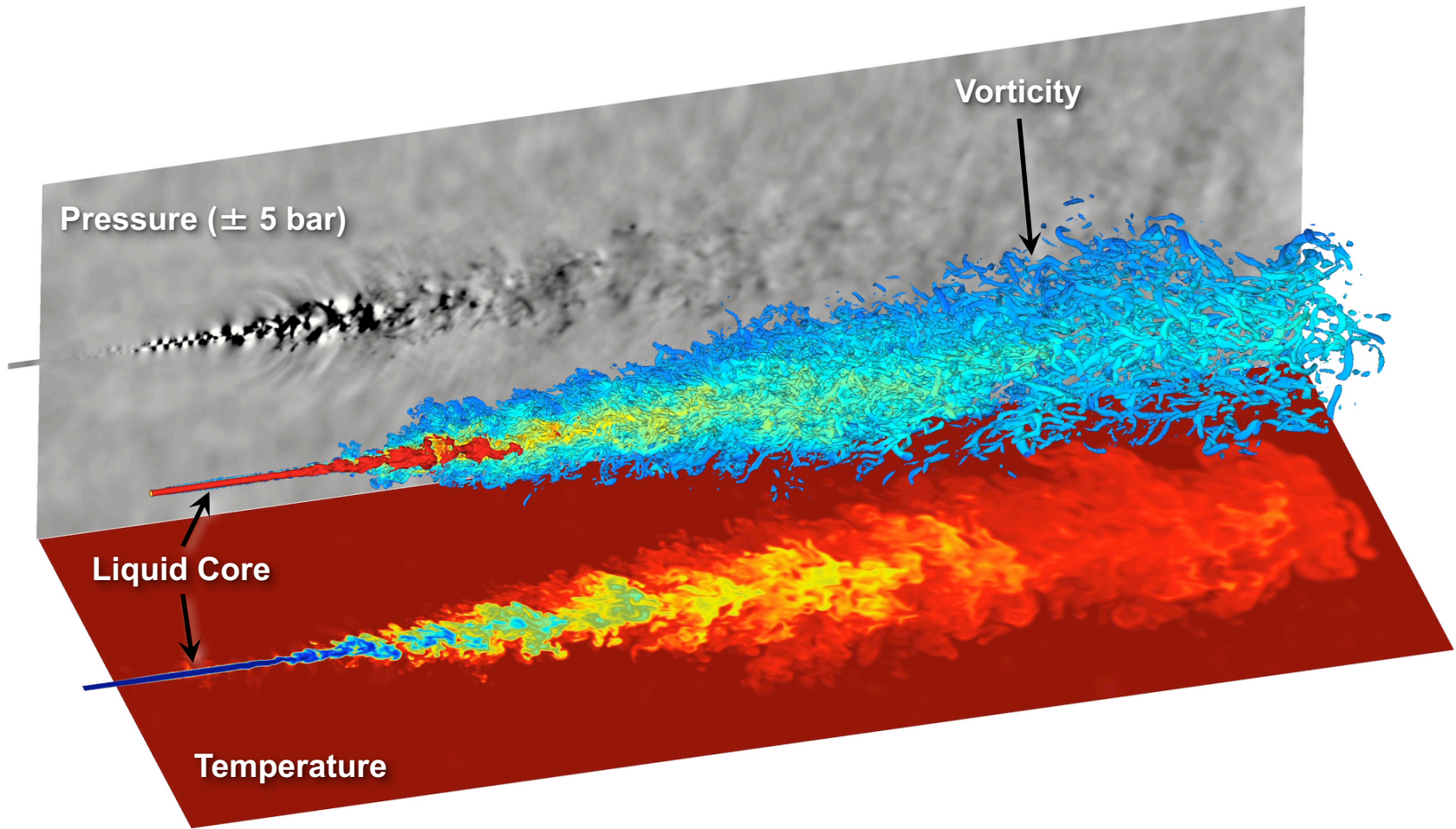

Large Eddy Simulation by Joe Oefelein & Guilhem Lacaze

Beam Steering

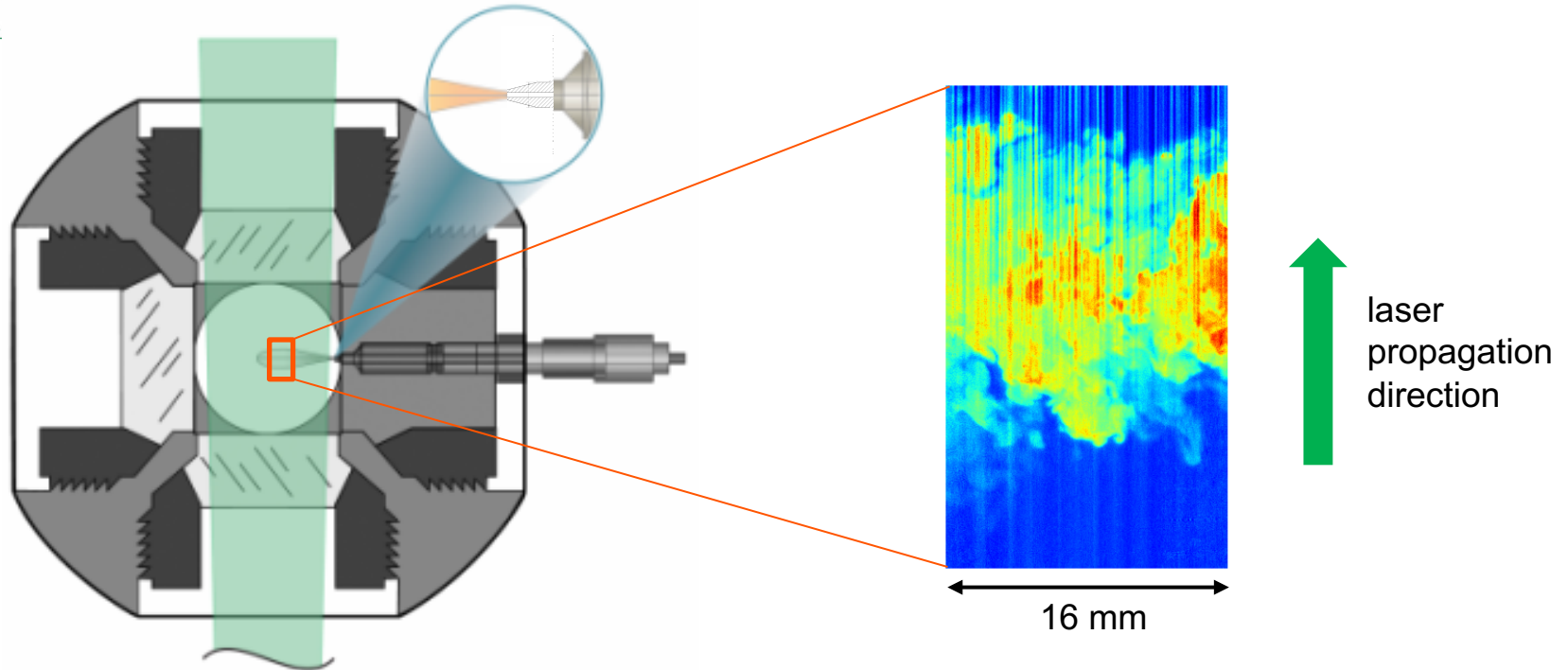

How to correct for beam steering artifacts?

- Ray-tracing algorithms have proven useful at atmospheric pressure (Kaiser, Frank, Long *Appl. Opt.* 2005).
- Challenge for ray-tracing increases with pressure.
- Investigate additional approaches

Development of Beam Steering Correction for High-Pressure Imaging

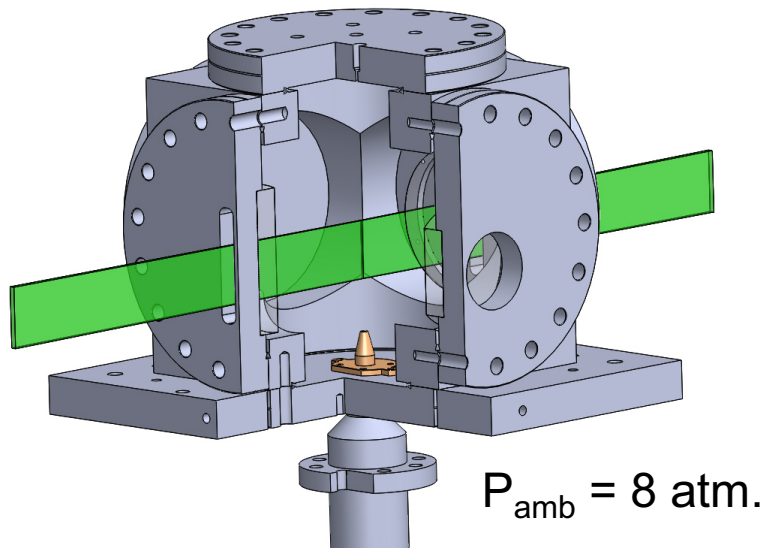

Laser Propagation Direction

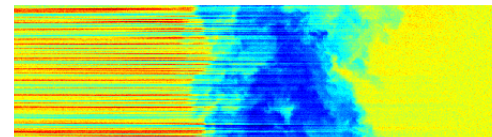

Only corrected for
Incident beam profile

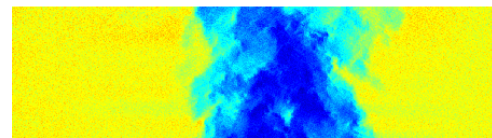

Wavelet-based beam-
steering corrections

7 mm

Developed wavelet-based method to correct for beam-steering effects while minimizing impact on physical structures

Rayleigh Scattering Imaging of Transient Gas Jet at Elevated Pressure

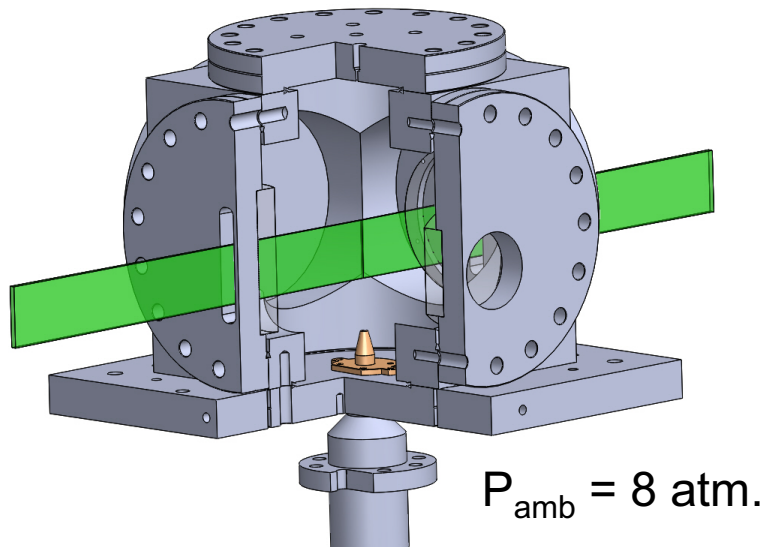

Transient injection of He
into CH_4 bath gas

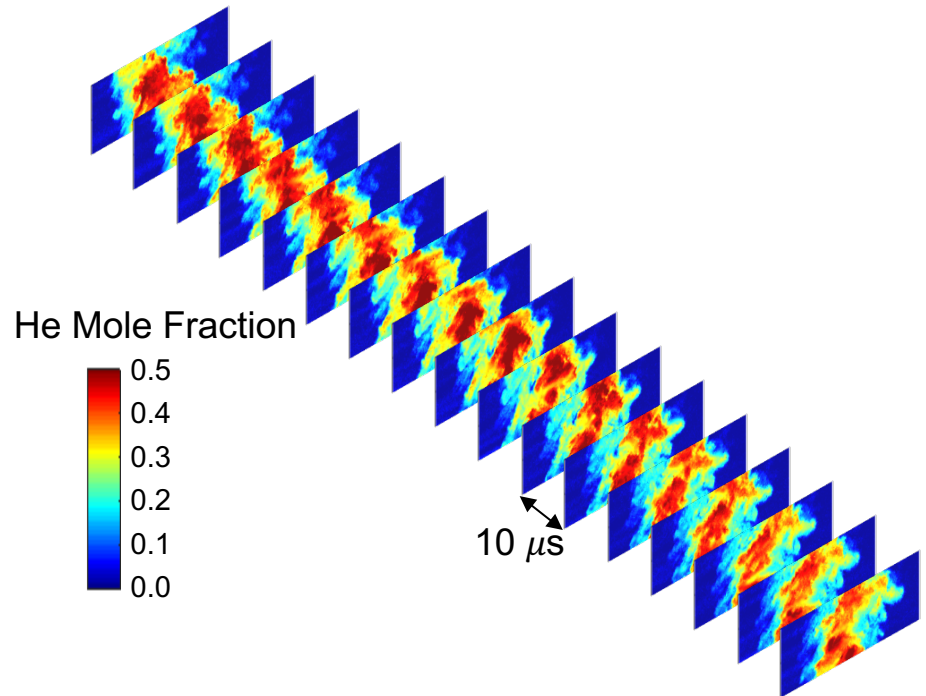

Transient spray mixture fraction measured in vaporized region of non-reacting injection

- Rayleigh scattering quantifies transient mixture fraction / equivalence ratio
 - Target condition Spray A has massive research effort to understand engine spray combustion (Engine Combustion Network)
- Jet mixing - large structures shed to side and re-entrained
 - Larger residence time in hot mixtures
- Target for high-fidelity LES studies
 - Verify turbulent mixing field as preliminary step towards predicting ignition/combustion

150 kHz schlieren imaging

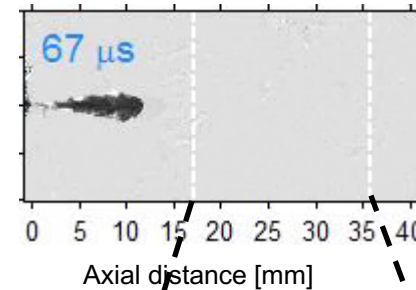

Ambient Gas
900 K
60 bar
15% O₂

Region of interest for ignition and lift-off stabilization

Fuel mixture fraction

Planar Rayleigh

Equiv. Ratio (15% O₂)

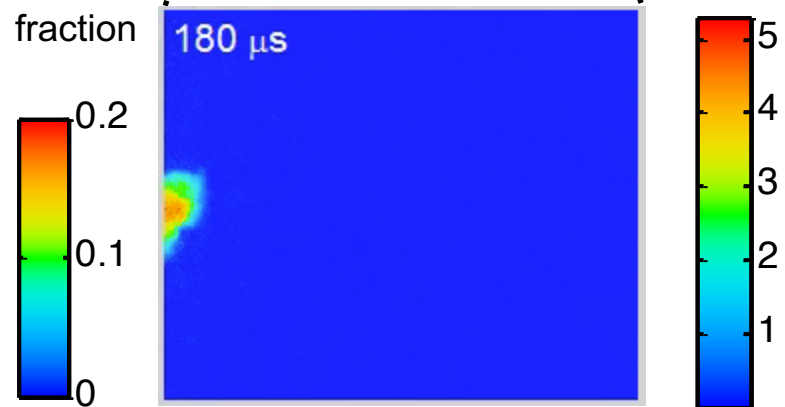

Ambient Gas
900 K
60 bar
0% O₂

Transient Temperature History Important for Ignition

- Rayleigh scattering quantifies transient mixture fraction / equivalence ratio
 - Target condition Spray A has massive research effort to understand engine spray combustion (Engine Combustion Network)
- Jet mixing - large structures shed to side and re-entrained
 - Larger residence time in hot mixtures
- Target for high-fidelity LES studies
 - Verify turbulent mixing field as preliminary step towards predicting ignition/combustion

150 kHz schlieren imaging

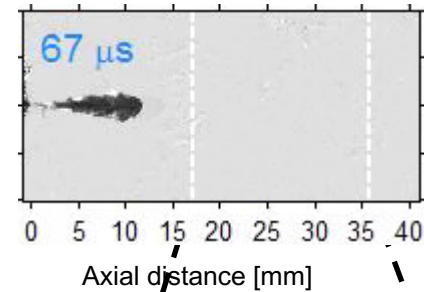

Ambient Gas
900 K
60 bar
15% O₂

Region of interest for ignition and lift-off stabilization

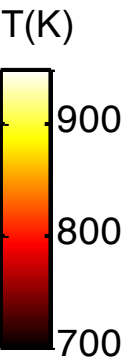
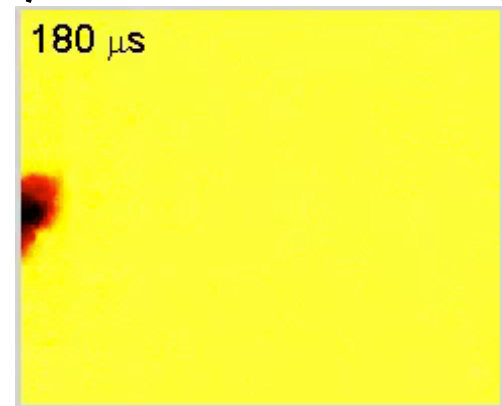

Ambient Gas
900 K
60 bar
0% O₂