

# Uncertainty Analysis of an Electric Field Mill Calibration System

Elizabeth Auden<sup>1</sup>, James Novak<sup>1</sup>, Ruben Salazar<sup>1</sup>, and Alan Hinckley<sup>2</sup>

<sup>1</sup>Sandia National Laboratories, <sup>2</sup>Campbell Scientific

# Outline

**Goal:** 4:1 TUR calibration system for parallel plate-mounted field mill

- Motivation: electric field mills and safety
- How electric field mills work
- How to calibrate electric field mills
- Calibration system standards and components
- Uncertainty analysis

## **Acronyms:**

- T-o-T: time of test
- TUR: test uncertainty ratio
- Uc: uncertainty

# Motivation: safety

**Electric field mills measure the potential gradients associated with atmospheric electric fields.**

**Use: early warning system for lightning detection**



C. Clark, NOAA Photo Library, NOAA Central Library; OAR/ERL/National Severe Storms Laboratory (NSSL)

# Electric field mill operation

Rotational electric field mills expose a sensor to an electric field through a grounded, rotating shutter.

## Open shutter:

- Electric field  $E$  induces charge on sensor
- Charge is measured as voltage  $V$

## Closed shutter:

- Charge on sensor dissipates

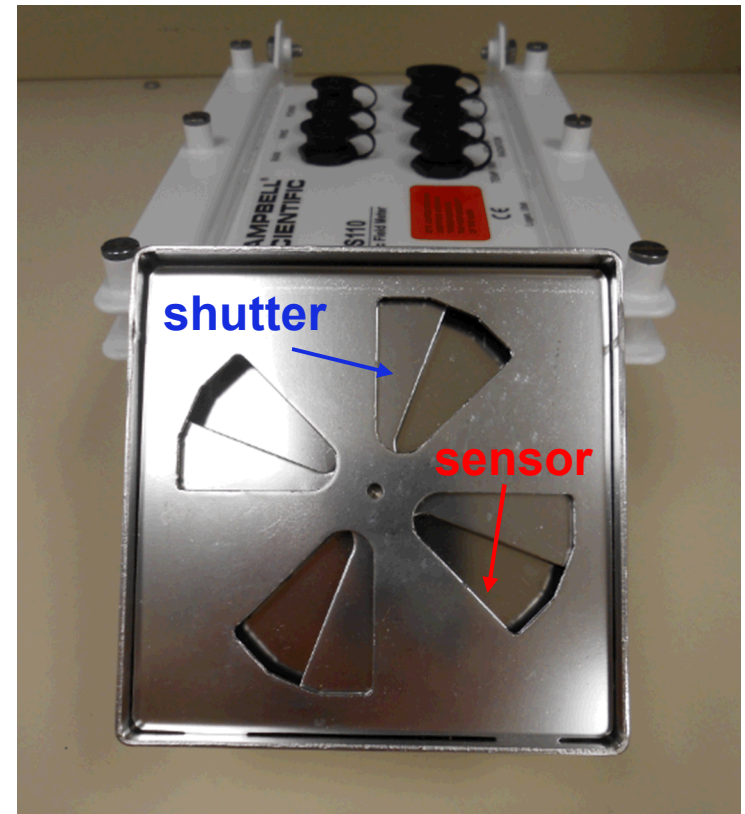
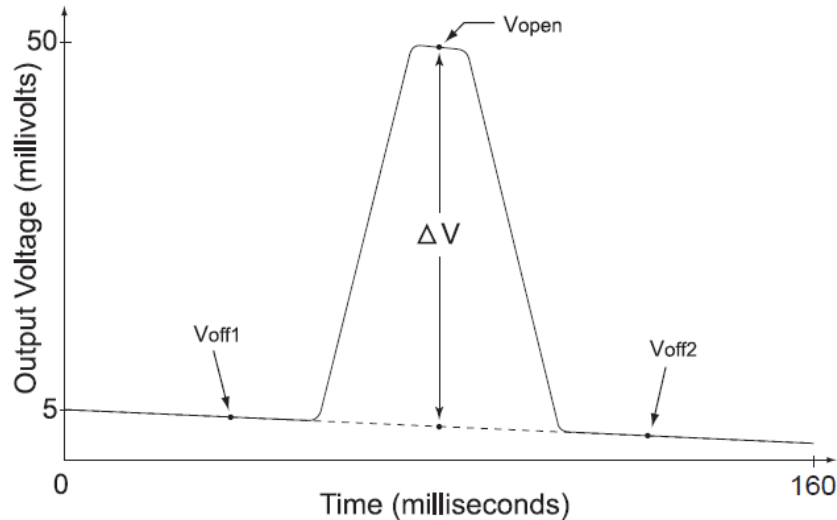

Output voltage as shutter rotates during exposure to electric field, after *CS110 Electric Field Meter Rev. 4/12*

Electric field mill with partially open shutter

# CS110 Electric field mill

Tolerance of field mill under test:

- $\pm(5\% + 8 \text{ V/m})$  mounted in tripod configuration
- $\pm(1\% + 60 \text{ V/m})$  mounted in parallel plate configuration



Tripod-mounted electric field mill, CS110  
*Electric Field Meter*, Rev. 4/12, p. 15



Electric field mill mounted in parallel plate  
test structure

# Calibration of electric field mill

Calibrate an electric field mill by using it to measure a known electric field.

$$E = V/d$$

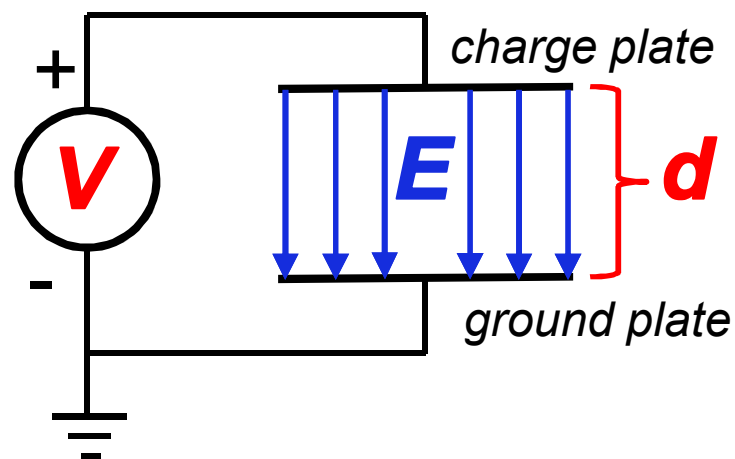

**Basic idea:**

known voltage divided by known distance = known electric field

# Calibration system

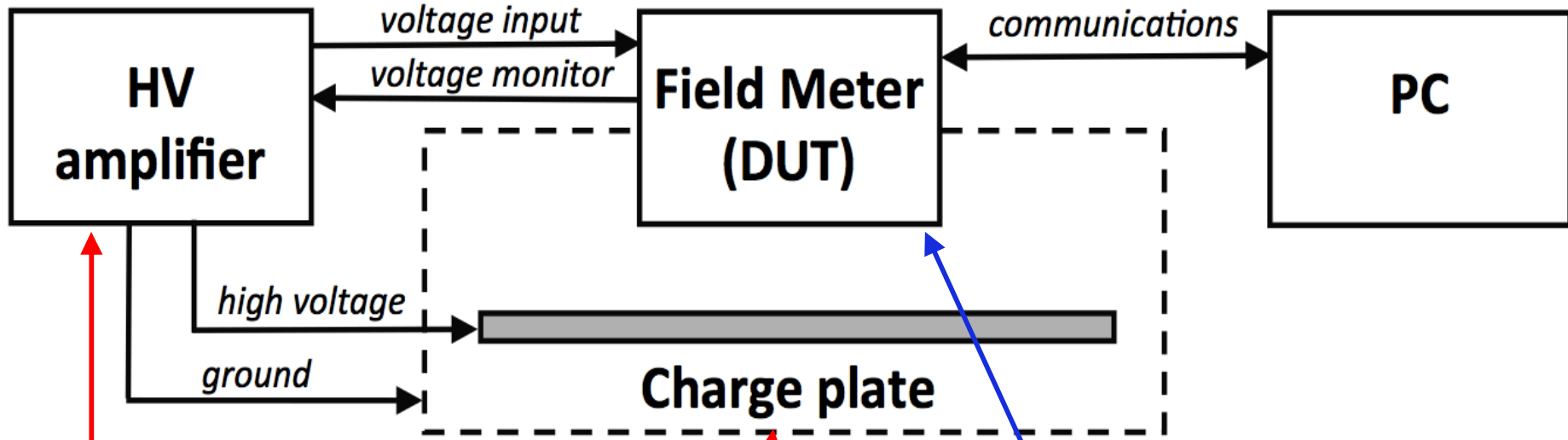

**HV amplifier**  
Standard  
*Voltage calibration*

**Parallel plate structure**  
Standard  
*Length calibration*

**Field mill**  
DUT  
*Electric field calibration*

# HV amplifier voltage calibration

HV amplifier's voltage output between -4 kV and +4 kV was measured to verify manufacturer's specified tolerance of  $\pm 0.1\%$ .

## Standards:

- 10,000:1 reference voltage divider
- Calibrated digital multimeter

## Other contributions to uncertainty:

- Type A measurement  $u_c$
- Voltage coefficient
- Connections, temperature, etc.
- T-o-T  $u_c$  @  $k=2 = \pm 0.012\%$

*Ratio of tolerance to calibration system  
 $u_c$  @  $k=2$  exceeds 4:1*

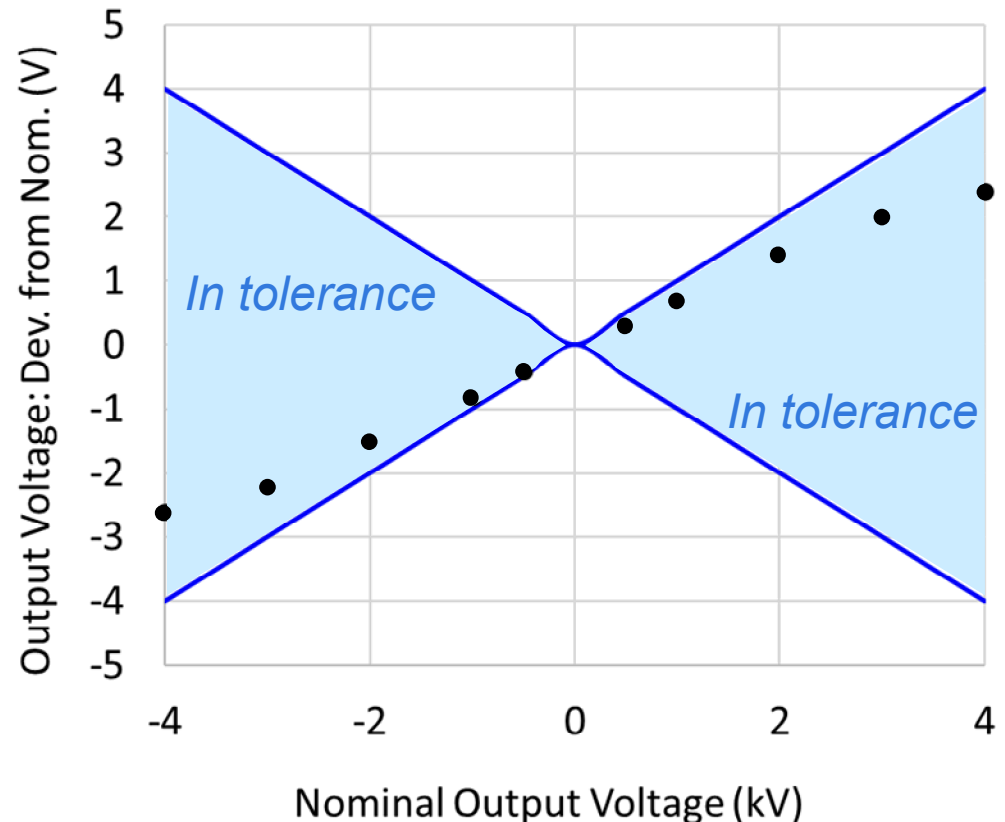

# Parallel plate distance calibration

Distance between outer ground plate and internal charge plate was measured at 8 points around the parallel plate opening.

## Measurement tool:

- Inside micrometer calibrated against gage block set
- Average distance = 6.232"
- Expanded uc @  $k=2 = \pm 0.025"$

Ratio of tolerance to calibration system  
uc @  $k=2$  exceeds 4:1

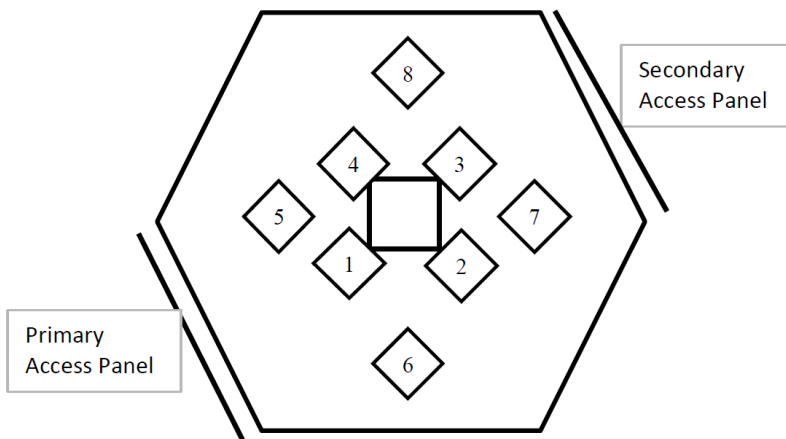

Measurement points on parallel plate structure

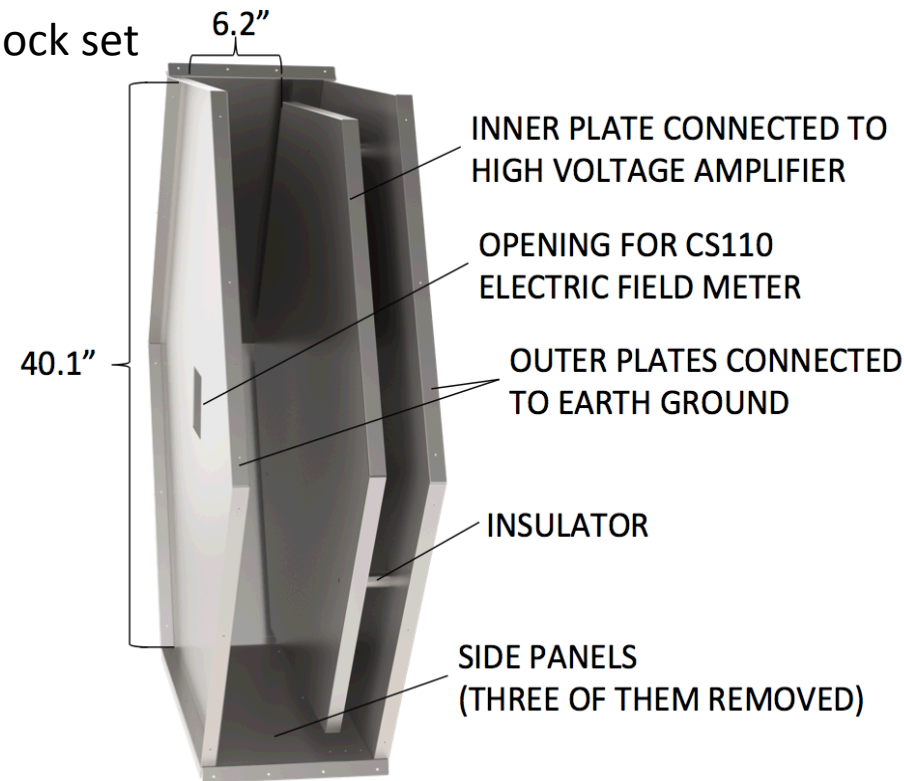

Diagram of parallel plate structure

# Gage R&R study

A “mini” gage R&R study captured contributions to uncertainty from type A measurement uncertainty and operator variability.

45 data runs:

- 3 operators
- 3 system set-ups per operator
- 5 data runs per system set-up

$$E = M_{pp}V + O_{pp}$$

<u>Symbol</u>	<u>Definition</u>
E	applied electric field (V/m)
V	voltage measured by field mill (mV)
$M_{pp}$	parallel plate multiplier (V/m/mV)
$O_{pp}$	offset (V/m)

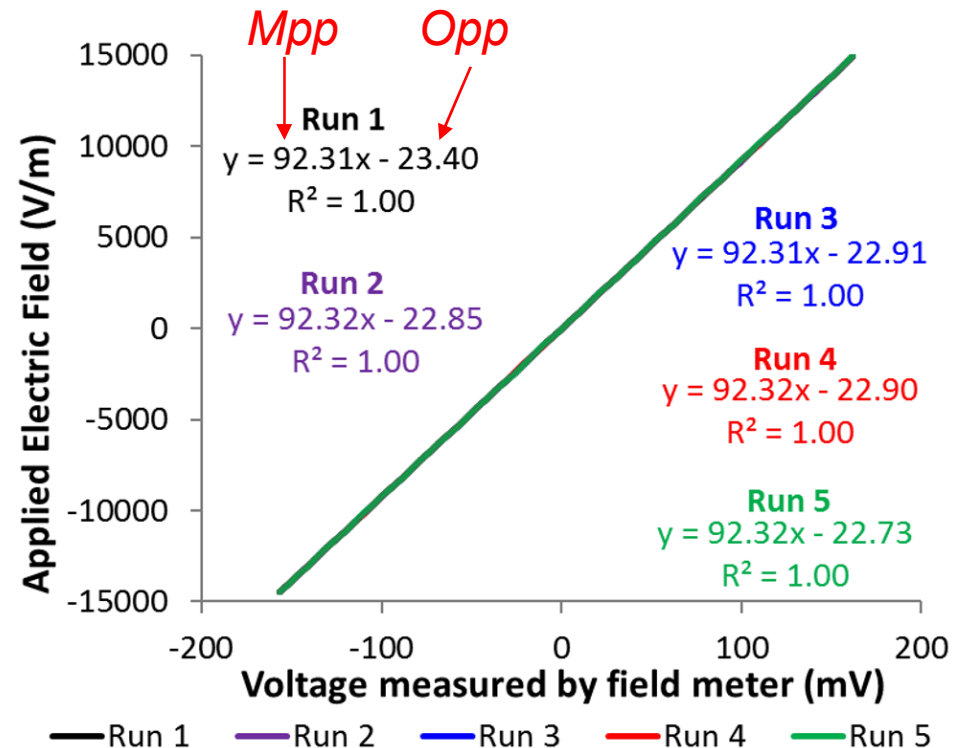

$M_{pp}$  and  $O_{pp}$  calculations from linear regressions of 5 runs by 1 operator for 1 set-up

# Type A Uc and Operator Variability

The parallel plate multiplier constant  $Mpp$  was used as the metric for Type A measurement uncertainty and operator variability.

## Type A measurement uncertainty:

- Calculated as maximum  $\text{std dev}(Mpp)$  observed in 5 runs by 1 operator in 1 set-up
- **Type A uc = 0.01%**

## Operator variability:

- Calculated as  $\text{std dev}(Mpp_{avg})$  for 3 operators in 3 set-ups per operator
- $Mpp_{avg}$  is average  $Mpp$  observed in 5 runs by 1 operator in 1 set-up
- Incorporates cables, connectors, temperature, field mill loading angle, etc.
- **Operator variability uc = 0.28%**

# Uncertainty Analysis

Cause of Uncertainty	Symbol	Contribution to Uncertainty
HV amplifier voltage <sup>1</sup>	$u_{HV}$	0.06%
Parallel Plate test structure distance	$u_{PP}$	0.20%
Operator variability (cords, connection, field mill angle)	$u_{OV}$	0.28%
Type A measurement uncertainty	$u_A$	0.01%
<b>Standard uncertainty at <math>k = 1</math></b>	$u_c$	<b>0.35%</b>

$$u_c = \sqrt{u_{HV}^2 + u_{PP}^2 + u_{OV}^2 + u_A^2}$$

<sup>1</sup> We assume that the amplifier's output voltage has a uniform distribution within its tolerance of  $\pm 0.1\%$ , so the associated standard uncertainty is  $\pm 0.1\%/\sqrt{3}$  after *NIST Technical Note 1297*, 1994 ed.

# Tolerance and TUR

In-tolerance status and TUR are calculated at each measured electric field value between -15 kV/m and +15 kV/m.

- Field mill tolerance:  $\pm(1\% \text{ (electric field)} + 60 \text{ V/m})$
- System uncertainty:  $\pm(0.35\% \text{ (electric field)})$

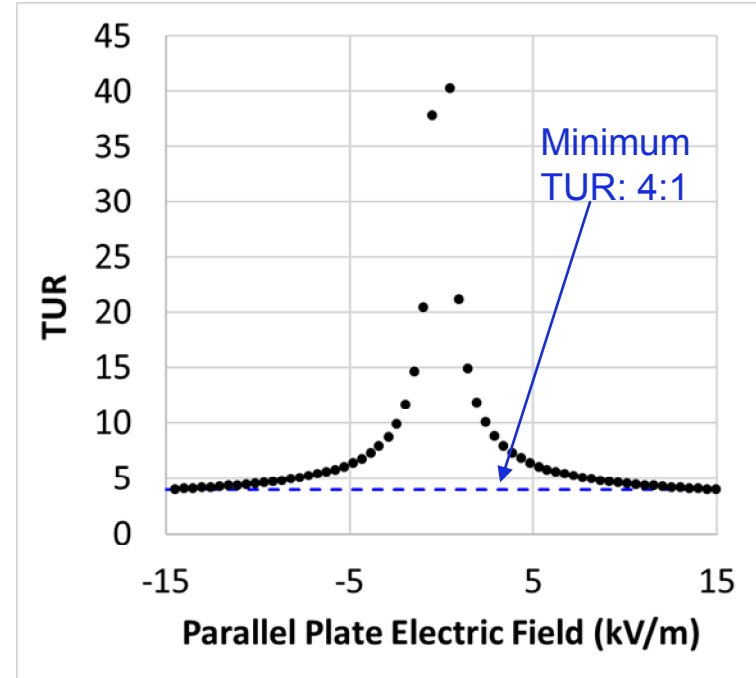
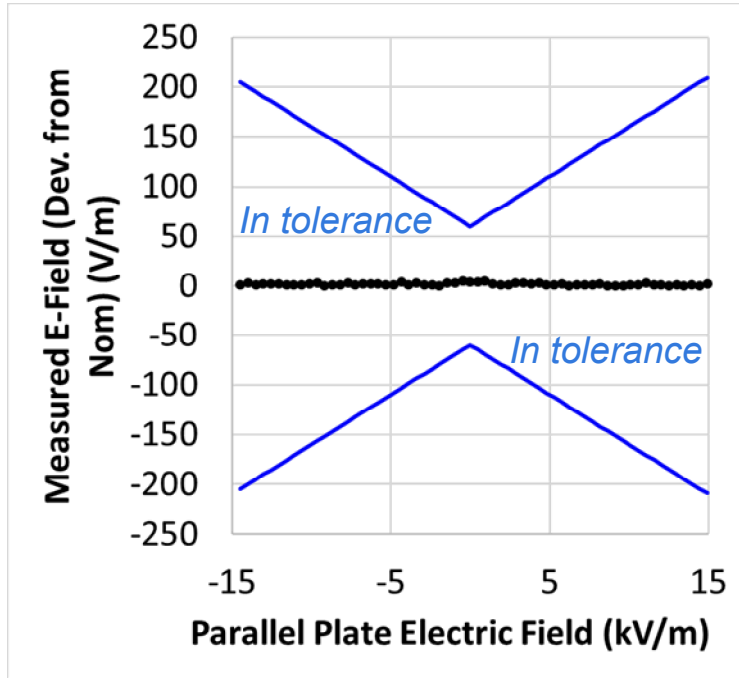

$$TUR = \frac{Upper\ Limit\ (E_{plate_{Avg}}) - Lower\ Limit\ (E_{plate_{Avg}})}{2 * standard\ uncertainty}$$

# Future work: reduce angle $\theta$

The loading angle of the electric field mill in the parallel plate test structure affects the electric field magnitude sensed on different portions of the sensor.

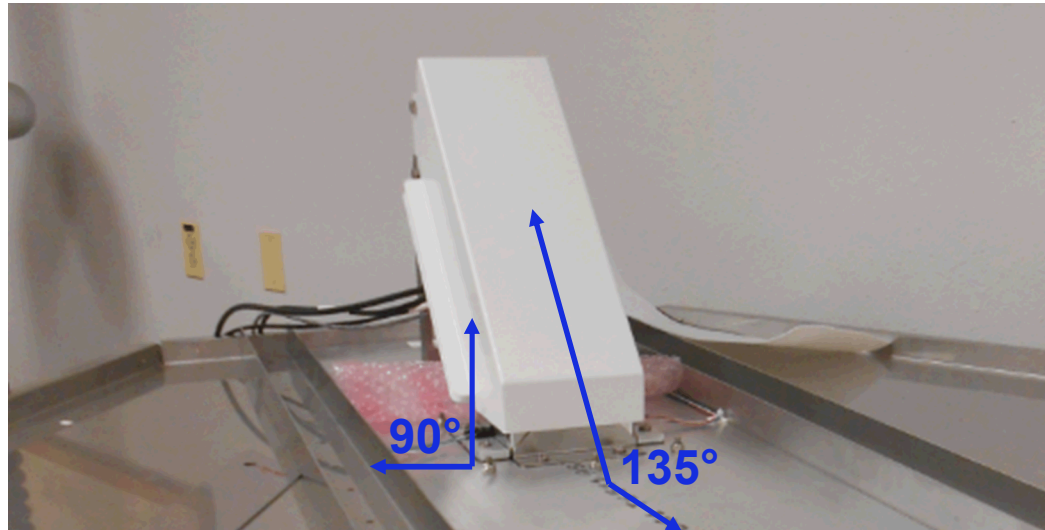
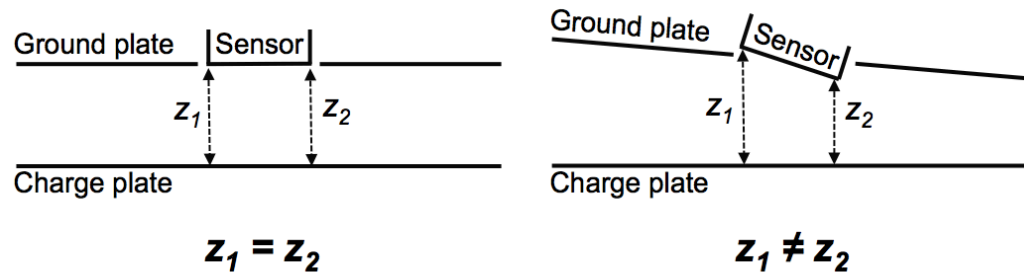

# Conclusions

**This calibration system meets a 4:1 TUR for electric field mills calibrated in a parallel plate test structure.**

Future work:

- Reduce uncertainty associated with loading angle
- Use calibrated angle tool for both  $135^\circ$  and  $90^\circ$  loading angles

## Questions?