

# A simplified regression building thermal modelling method for detached two-floor house in U.S.

Borui CUI<sup>1\*</sup>, Jin DONG<sup>1</sup>, Jeffrey MUNK<sup>1</sup>, Ning MAO<sup>2</sup>, Teja KURUGANTI<sup>1</sup>

<sup>1</sup>Oak Ridge National Laboratory,  
Oak Ridge, TN, USA  
{cuib, dongj, munkjd, kurugantipv}@ornl.gov

<sup>2</sup>Department of Gas Engineering, College of Pipeline and Civil Engineering, China University of Petroleum (East China), Qingdao, China  
maoningcas@hotmail.com

\* Corresponding Author

## ABSTRACT

The residential building sector accounts for approximately 37% of total U.S. electricity consumption. Within the residential building sector, heating and cooling is the main target for peak load shifting/reduction since it is the largest contributor to peak demand. In fact, the flexibility of residential HVAC loads can provide continuous variation of demand to provide grid services by varying their demand over a baseline. The performance of HVAC load control to provide grid services relies heavily on the accuracy of indoor air temperature or cooling/heating demand predictions and therefore the quality of building model. Besides forward models, popular building models are data-driven models which can be broken down into two categories: gray-box model, e.g. Resistance-Capacitance (RC) model and black-box model. RC model, also called lumped capacitance or network model, which is constituted with electrical analogue pattern with resistance ( $R$ ) and capacitance ( $C$ ). In general, RC models require considerable computation burden and long periods of data to train limited number of model coefficients. Black-box models have gained increasing interest due to their capability in analyzing large-scale data and flexibility in practical applications. But, the data-mining based (machine learning algorithms/techniques based) models tend to have invisible model structures which poses a problem when trying to use the model for optimal control or model predictive control of the HVAC system.

Hence, there is a continuing need for efficient online system identification techniques, which can provide explicit parameters for the model. Traditional regression models fit well for this specific purpose. This paper presents an innovative way to predict average indoor temperature in separate floors of typical detached residential house. A rolling horizon linear regression model, which includes online adaptive correction component, is proposed to predict the temperature difference between downstairs and upstairs. A RC model is used to predict the overall mean indoor air temperature. Since the adaptive algorithm needs to be implemented online, a less computation-demanding polynomial fitting algorithm is adopted. This kind of fitting problem can be cast as linear regression problem with multiple variables, parameters of which can be efficiently obtained by well-known gradient descent method.

The validation is conducted by comparing the predicted results with the results from data-mining based models as well as measured data from a real typical detached two-floor house. The results show that the developed method has satisfactory performance in predicting the building indoor temperature in 1st and 2nd floors.

## 1. INTRODUCTION

There were over 132 million housing units in the U.S., and of those 87% had heating, ventilation and air conditioning

---

This manuscript has been authored by UT-Battelle, LLC under Contract No. DE-AC05-00OR22725 with the U.S. Department of Energy. The United States Government retains and the publisher, by accepting the article for publication, acknowledges that the United States Government retains a non-exclusive, paid-up, irrevocable, worldwide license to publish or reproduce the published form of this manuscript, or allow others to do so, for United States Government purposes. The Department of Energy will provide public access to these results of federally sponsored research in accordance with the DOE Public Access Plan (<http://energy.gov/downloads/doe-public-access-plan>).

(HVAC) systems. In the southern United States, the percentage of homes with air conditioning approaches 100% [Cole, *et al.*, 2014]. These air conditioning (AC) units tend generate considerable peak power demand. In recent research work, multiple AC optimal control and demand response methods have been proposed [Cui, *et al.*, 2017].

It worth noticing that the accuracy and applicability of building thermal models used in these methods has considerable impact on the operating performance. Building thermal model which characterizes the properties of both building envelop and thermal mass contains significant thermal mass that can function like batteries to store and release energy for peak demand limiting, energy management and demand response with low cost and less environmental pollution [Moteji, *et al.*, 2005]. It can be used as passive thermal storage to store cooling energy by implementing AC control measures, such as decreasing indoor temperature set-point during off-peak period. The stored cooling will be released by increasing indoor set-point or shutting down AC during on-peak period [Cui, *et al.*, 2015]. Therefore, building thermal model is essential for developing building thermal solution. There are two main categories of building modeling methods according to ASHRAE: “Forward” and “Data-Driven” [ASHRAE, 2013]. Forward (white-box) model has parameters of physical significance but requires a relatively larger amount of building knowledge for practical implementations, which leads to unfit for large-scale optimal control. Data-driven models adopt an inverse approach for model development, assuming that there are certain mathematical relationships between model inputs and outputs [Dong, *et al.*, 2016]. Data-driven models can be further categorized into “black-box” and “gray-box” models. The most popular gray-box method is Resistance-Capacitance(RC) model, also called lumped capacitance or network model. The values of R and C, are estimated based on samples of inputs and outputs by applying an identification algorithm, e.g. nonlinear regression algorithm, which typically minimizes a norm of either simulation errors or prediction errors [Kim, *et al.*, 2016]. The RC models require relatively long periods of data to train model coefficients as well as considerable training time and computation burden. Black-box models have gained more and more interests due to their capability in analyzing large-scale data and flexibility in practical applications. Instead of high granularity data inputs, the developed black-box models are generally applied to predict overall power consumption in a house based on low granularity data inputs, such as past monthly utility bills [Edwards, *et al.*, 2012]. Meanwhile, the data-mining based models tend to have invisible model structures which poses a problem when trying to use the model for optimal control or model predictive control of the HVAC system.

In typical detached two-floor house in U.S., it is usual to use one AC system to realize controls of the respective temperatures in downstairs and upstairs by dampers. Alternatively, some new built houses are installed with two independent AC systems for downstairs and upstairs respectively. Therefore, there is a need to predict respective temperatures in upstairs and downstairs for practical and efficient optimal control of AC system. In this research, a simplified regression building modelling method is proposed to predict average indoor temperature in separate floors of typical detached residential house. A rolling horizon model, which includes online adaptive correction component, is proposed to predict the temperature difference between downstairs and upstairs. A RC model is used to predict the overall mean indoor air temperature. Since the adaptive algorithm needs to be implemented online, a less computation-demanding polynomial fitting algorithm is adopted. This kind of fitting problem can be cast as linear regression problem with multiple variables, parameters of which can be efficiently obtained by well-known gradient descent method.

## 2. Description of reference house and AC system

As shown in Figure.1, the reference building being modelled in this research is a typical, single-family, detached house located in Knoxville, Tennessee. It was built in 2013 and is part of a large subdivision of similar homes built around the same time. The 2-story, 223 m<sup>2</sup> (2,400 ft<sup>2</sup>) was built to meet the International Energy Conservation Code (IECC) 2006 [60]. The AC system consists of a fan-coil air handler with variable-speed blower, a variable-speed heat pump and a zoning system which splits the house into two zones, i.e. upstairs and downstairs. The dampers in the zoning system are used to control airflow. Single damper position is indicated by a number which ranges from 0 to 15. 0 means fully closed and 15 means fully-open. The position of the damper is used to calculate to the ratio of supply air delivered to each zone. In this research, the overall mean indoor air temperature, i.e.  $T_{ave}$ , is set as the average of measured temperatures from two sensors,  $T_1$  and  $T_2$ , which are in downstairs and upstairs respectively. The overall mean indoor air temperature (average indoor air temperature of both floors) is defined as the average of measured temperatures from two sensors which are located near the thermostats downstairs and upstairs respectively, as shown in Figure. 2. The measured temperatures from these two sensors are assumed to be mean average temperatures for downstairs and upstairs respectively.



**Figure 1:** A view of reference house in Tennessee

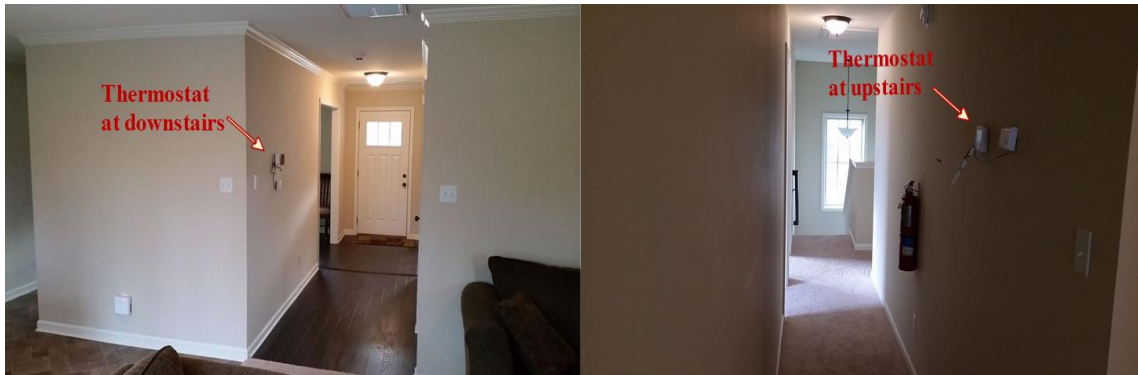

**Figure 2:** Thermostats at downstairs and upstairs

### 3. Models development

This section presents the gray-box, i.e. RC, model development for prediction of overall mean indoor air temperature. The developed online rolling horizon model is then introduced.

#### 3.1 RC model development

A 4R4C mode is proposed in this study, as shown in Figure 3, to predict overall mean indoor temperature, i.e.  $T_{ave}$ . The heat transfer in the building model is described using the following set of first-order differential equations:

$$C_w \frac{dT_{wall}(t)}{dt} = \frac{T_{sol,w}(t) - T_{wall}(t)}{R_w/2} - \frac{T_{wall}(t) - T_{ave}(t)}{R_w/2} \quad (1)$$

$$C_{in} \frac{dT_{ave}(t)}{dt} = \frac{T_{wall}(t) - T_{ave}(t)}{R_w/2} + \frac{T_{attic}(t) - T_{ave}(t)}{R_{attic}} + \frac{T_{im}(t) - T_{ave}(t)}{R_{im}} + C_1 Q_{int} + C_2 Q_{AC} \quad (2)$$

$$C_{attic} \frac{dT_{attic}(t)}{dt} = \frac{T_{sol,r}(t) - T_{attic}(t)}{R_{roof}} - \frac{T_{attic}(t) - T_{ave}(t)}{R_{attic}} \quad (3)$$

$$C_{im} \frac{dT_{im}(t)}{dt} = - \frac{T_{im}(t) - T_{ave}(t)}{R_{im}} + C_3 Q_{solar} \quad (4)$$

$R_{attic}$ ,  $R_{im}$ ,  $R_{roof}$ , and  $R_w$  are the equivalent overall thermal resistance of attic floor, internal thermal mass, roof and walls (K/W) respectively.  $C_{attic}$ ,  $C_{im}$ ,  $C_{in}$  and  $C_w$  are the equivalent overall thermal capacitances of attic air, indoor air, internal mass and external walls, (J/K) respectively. All resistances and capacitances are assumed to be time-invariant.

It is necessary to consider the building internal mass, which includes interior partitions and furniture, independently since the effect of building internal mass on cooling/heating energy consumption and indoor temperature is significant.  $Q_{int}$  is the sum of sensible internal heat load (W) from indoor heat resources, such as human, equipment and lighting, which is approximated by adding the sum of circuits, i.e. the total electrical energy use for each electrical circuit in the house, on each level for the separate floor.

The solar radiation through window is characterized by  $Q_{solar}$  (W) in the following:

$$Q_{solar} = F_{win}(t)I(t)A_{win,tot}SHGC \quad (5)$$

where,  $I$  is the direct normal solar irradiance ( $W/m^2$ ).  $A_{win,tot}$  is the total window area ( $m^2$ ).  $SHGC$  is the solar heat gain coefficient of windows.  $F_{win}$  is the area-weighted average of view factors of windows with different orientations, which are calculated using a solar calculator spreadsheet developed by NOAA [NOAA]:

$$F_{win}(t) = \frac{\sum_{i=1}^4 A_{win,i} F_i(t)}{\sum_{i=1}^4 A_{win,i}} \quad (6)$$

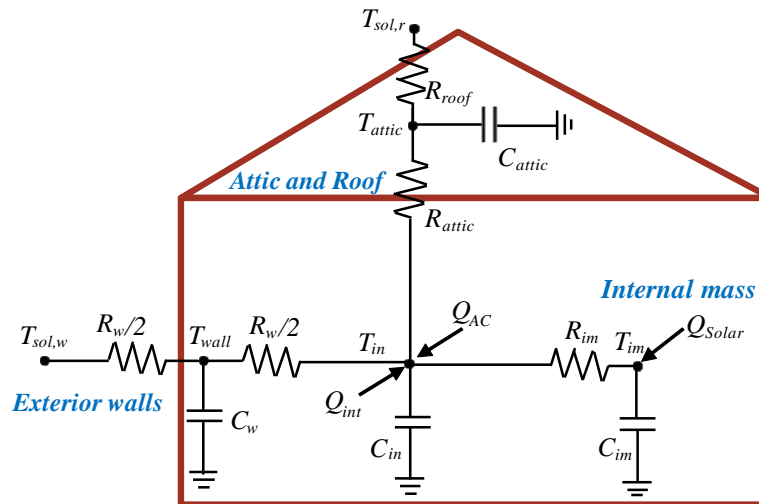

**Figure 3:** Schematics of the simplified building thermal network model (4R4C)

Subscript  $i$  indicates the orientations, i.e. east, south, west and north.  $A_{win}$  is the general area of window ( $m^2$ ).  $F_i$  is the view factor for windows with different orientations. It worth noticing that one assumption is that available information is limited in terms of numbers of measure points, e.g. one indoor temperature data measurement available only.  $Q_{AC}$  is the total cooling capacity (W). The effective heating/cooling gain coefficients  $C_1$ ,  $C_2$  and  $C_3$  are therefore introduced.  $C_1$ ,  $C_2$  and  $C_3$  are used to adjust  $Q_{int}$ ,  $Q_{AC}$  and  $Q_{solar}$  for unknown factors. All  $C_1$ ,  $C_2$  and  $C_3$  are assumed to be unknown and need to be identified by searching algorithm illustrated latter.

The effects of solar radiation on walls and roof are considered by calculation of  $T_{sol,w}$  and  $T_{sol,r}$  respectively, which are the sol-air temperatures, shown in the followings:

$$T_{sol,w} = \frac{\alpha_w}{h(t)} F_w(t) I(t) + T_{out} \quad (7)$$

$$T_{sol,roof} = \frac{\alpha_{roof}}{h(t)} F_{roof}(t) I(t) + T_{out} \quad (8)$$

where,  $\alpha$  is the absorption coefficient of wall and roof.  $T_{out}$  is outdoor dry bulb temperature ( $^{\circ}C$ ).  $h$  is convective heat transfer coefficient of roof and exterior wall surfaces ( $W/m^2 K$ ), which is calculated by the correlation between  $h$  and wind speed developed from ASHRAE Handbook [ASHRAE, 2013]:

$$h = xV_{wind} + y \quad (9)$$

where,  $V_{wind}$  is the wind speed (m/s).  $x$  and  $y$  are the regression coefficients.

$F_w$  and  $F_{roof}$  in Equation (10) and (11) are the area-weighted averages of view factors of exterior walls and roofs with different orientations. where,  $A_w$  is the general area of each wall (m<sup>2</sup>).  $F_i$  is the view factor for walls with different orientations. Subscript  $j$  indicates the orientations, i.e. north and south, of roof.

$$F_w(t) = \frac{\sum_{i=1}^4 A_{w,i} F_i(t)}{\sum_{i=1}^4 A_{w,i}} \quad (10)$$

$$F_r(t) = \frac{\sum_{j=1}^2 F_j(t)}{2} \quad (11)$$

Given a set of parameters, the RC model predict the profile of overall mean indoor air temperature, i.e.  $T_{ave}$ , then we can evaluate the fitness between the prediction results and measured data by the objective function. The objective function of the optimization employs the integrated root-mean-square-error (RMSE), as defined in Equation (12):

$$J(R_w, R_{roof}, R_{attic}, R_{im}, C_w, C_{im}, C_{attic}, C_{in}, C_1, C_2, C_3) = \sqrt{\frac{\sum_{k=1}^N (T_{in,mea} - T_{in,simu})^2}{N-1}} \quad (12)$$

where,  $T_{ave,act}$  is the measured overall average building indoor dry bulb temperature.  $T_{ave,simu}$  is the result from the model. The parameters are identified by particle swarm optimization (PSO) method. As one of the swarm intelligence algorithms, PSO has a well-balanced mechanism to enhance and adapt global and local exploration abilities [Kusiak, *et al.*, 2010].

### 3.2 Online rolling horizon linear regression model development

Multiple linear regression attempts to model the relationship between two or more explanatory variables and a response variable by fitting a linear equation to observed data. Every value of the independent variable  $x$  is associated with a value of the dependent variable  $y$ . Multivariate linear regression at one-time step is shown:

$$y_{\theta}(x(k)) = \theta_0 + \theta_1 x_1(k) + \theta_2 x_2(k) + \dots + \theta_n x_n(k) \quad (13)$$

Where,  $n$  is number of features,  $x_i$  is input feature,  $y(x(k))$  is output measurement that we are predicting.  $\theta_i$  denotes all the parameters or coefficients.  $k$  denotes time step for  $k=1, 2, \dots, m$ .

For convenience of notation, by simple linear algebra, we can define Equation (14) and Equation (13) can be re-written to Equation (15):

$$X = \begin{bmatrix} x_0 \\ x_1 \\ x_2 \\ \vdots \\ x_n \end{bmatrix} \in R^{n+1}, \quad \theta = \begin{bmatrix} \theta_0 \\ \theta_1 \\ \theta_2 \\ \vdots \\ \theta_n \end{bmatrix} \in R^{n+1} \quad (14)$$

$$y_{\theta}(x(k)) = \theta_0 + \theta_1 x_1(k) + \theta_2 x_2(k) + \dots + \theta_n x_n(k) = \theta^T X \quad (15)$$

The objective function  $J$  is to minimize the linear regression output and the observed data over the  $m$  time steps:

$$J(\theta) = \frac{1}{2m} \sum_{k=1}^m (h_{\theta}(x(k)) - y(k))^2 \quad (16)$$

Another way to interpret the cost function is to treat it as a function of the decision variables/coefficients  $\theta$ . Basically, we want to find the optimal set of parameters  $\theta_i$  that achieve the least errors over the past  $m$  measurements.

It's worth mentioning that, we will solve this optimization in an online moving horizon fashion. The heat transfer in the stair area due to the convection effect is hard to be observable or estimated, and this dynamic and intermittent heat transfer along with mass transfer is hard to be described by a simplified building thermal model, e.g. RC gray-box model. Therefore, we develop this adaptive learning model to update our linear regression model based on the most recent  $m$  measurements. Moving horizon means, as new measurement comes in, our model will keep updating the

model as well. Specifically, the developed moving horizon linear regression model is used to predict the temperature difference between downstairs and upstairs based on various available measurement data. Generally, this can be solved by standard gradient descent technique, which will guarantee the global minimum solution even when multiple features we chose are heterogeneous in physical meaning or scale. Two rolling horizon models with different number of input variables are developed. The first one with 4 variables, e.g. previous measured  $T_{amb}$ ,  $T_{attic}$ ,  $Q_{int,1}$ ,  $Q_{int,2}$ , is shown in Equation 17 and the second one with 6 variables, e.g. previous measured  $T_{amb}$ ,  $T_{attic}$ ,  $Q_{int,1}$ ,  $Q_{int,2}$ ,  $Q_{ac,1}$ ,  $Q_{ac,2}$ , is shown in Equation 18.

$$\Delta T = f_{Roll,L}(T_{amb}, T_{attic}, Q_{int,1}, Q_{int,2}) \quad (17)$$

$$\Delta T = f_{Roll,L}(T_{amb}, T_{attic}, Q_{int,1}, Q_{int,2}, Q_{ac,1}, Q_{ac,2}) \quad (18)$$

where,  $Q_{int,1}$  and  $Q_{int,2}$  are the sensible heat gain in downstairs and upstairs respectively.  $Q_{ac,1}$  and  $Q_{ac,2}$  are the cooling supply in down stairs and upstairs respectively,  $\Delta T$  represents the temperature difference between two floors.  $T_{amb}$  is the ambient temperature. In this research, we use previous 6 hours' measured data to update the model and predict the temperature difference between downstairs and upstairs in the future 1 hour.

## 4. Results and discussion

### 4.1 Training and testing results of the RC model

In this sub-section, the data collected from the reference building in different consecutive time periods with various operation conditions, e.g. different schedules of AC indoor temperature set-points, as well as different outdoor weather conditions are used for training and validating the RC model. The data collected from Apr 21, 2017 to May 15, 2017 are used for training section and the data collected from Jul 2, 2011 to Jul 14, 2017 are used for validation. The resulting parameters identified by PSO are:  $R_w = 0.0434$  K/W,  $R_{attic} = 0.0235$  K/W,  $R_{roof} = 0.00133$  K/W,  $R_{im} = 0.00094$  K/W,  $C_w = 5,138,697$  J/K,  $R_{roof} = 0.0013$  K/W,  $C_{attic} = 824,268$  J/K,  $C_{im} = 23,365,561$  J/K,  $C_{in} = 8,666,667$  J/K,  $C_1 = 0.666$ ,  $C_2 = 0.773$ ,  $C_3 = 0.1$ .

The data collected from Jul 2, 2011 to Jul 14, 2017 are used for model testing. The results are shown in Figure 4.  $T_{act}$  is the measured overall mean indoor air temperature and  $T_{RC}$  is the indoor temperature from the model for a 24-hour prediction horizon. To quantify the deviations of the predicted data from the measured data in both training session and validation sessions, two indices are used to evaluate the deviations: mean absolute error (MAE) and RMSE. Table 1 lists the two accuracy indices of the developed model in training and validation sessions. It can be found that the developed RC model has satisfactory performance in prediction of the overall mean building indoor temperature under different scenarios.

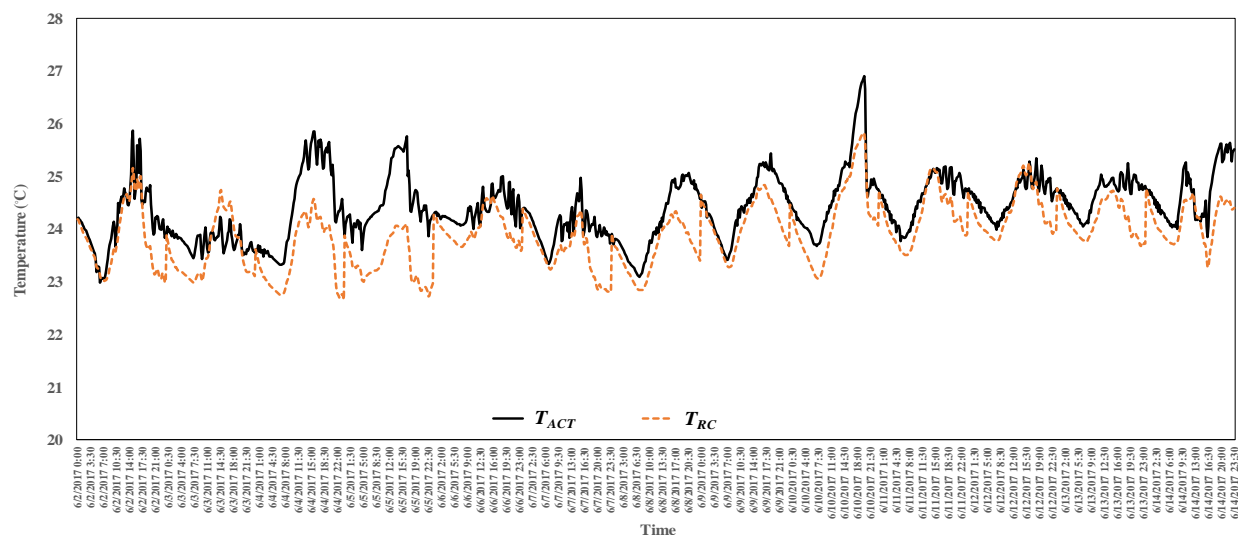

Figure 4: RC model testing results from Jun 2 to Jun 14, 2017

**Table 1:** Accuracy indices of the developed RC model

Time	Training/Testing	MAE	RMSE
Apr 21, 2017 to May 15, 2017	Training	0.345°C	0.458°C
Jul 2, 2011 to Jul 14 2017	Validation	0.531°C	0.654°C

## 4.2 Training and testing results of the online rolling horizon models

The validation/testing of online rolling horizon model is conducted by comparing the predicted results with the results from data-mining based models as well as measured data from a real typical detached two-floor house. Three machine learning algorithms, i.e. artificial neural network (ANN), random forests (RF) and gradient boosting tress (GBM), are also introduced to realize prediction of same variable for comparison with the results from rolling horizon model. They are relatively mature solutions in capturing complex relationships and their performance has been validated in previous studies. The Figure 5 shows the training results of the three machine learning algorithms. In the Figure 6, the testing results of both online rolling horizon models and data-mining based models are shown. The indices MAE and RMSE of the testing results from rolling horizon model and each machine learning method and is listed in Table 2. From table 2, we can conclude that the rolling horizon linear regression models have better accuracy. In addition, the model with 6 inputs, e.g.  $T_{amb}$ ,  $T_{attic}$ ,  $Q_{int,1}$ ,  $Q_{int,2}$ ,  $Q_{ac,1}$ ,  $Q_{ac,2}$ , has the best results.

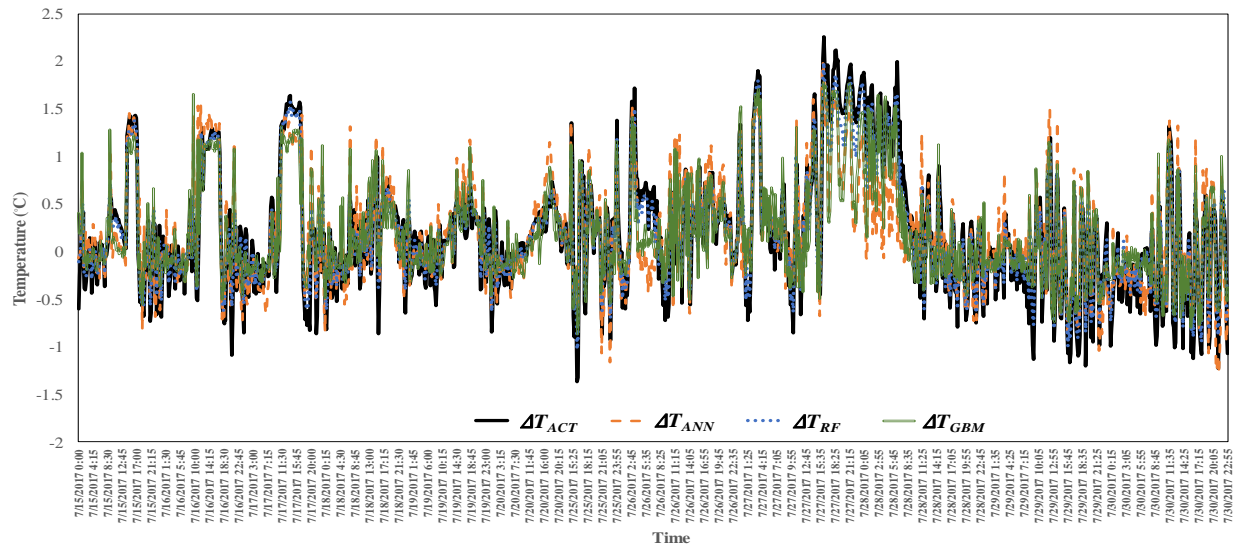
**Figure 5:** Training results of three machine learning algorithms**Table 2:** Prediction performance of each method.

Methods	MAE	RMSE
Rolling horizon (4 inputs)	0.485°C	0.816°C
Rolling horizon (6 inputs)	0.465°C	0.784°C
ANN	1.135°C	1.459°C
RF	1.204°C	1.509°C
GBM	1.171°C	1.507°C

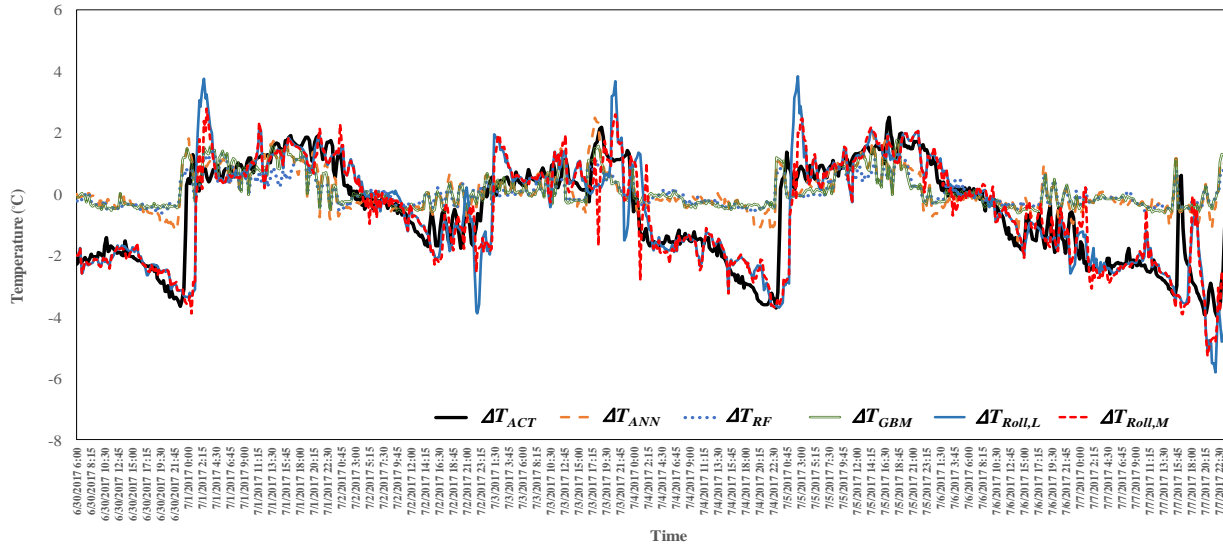

Figure 6: Testing results of rolling horizon models and data-mining based models

### 4.3 Performance evaluation of proposed modelling method

The overall performance evaluation of the proposed simplified regression building modelling method is conducted. The RC model is used to predict the overall mean temperature in the online rolling horizon model training/test period. The results are shown in Figure 7. The MAE and RMSE are 0.475°C and 0.611°C respectively. The final results, i.e. the predicted average temperatures in respective floors ( $T_1$  and  $T_2$ ), produced by RC model plus different black-box modeling methods are then calculated, as shown in Figure 8 and 9. The indices MAE and RMSE of the final results are listed in Table 3. Compared to the accuracies of the results from data-mining based models + RC model approach, the results from the rolling horizon model (6 inputs) + RC have the best prediction performance. The accuracy improvement is more obvious in terms of  $T_2$  prediction.

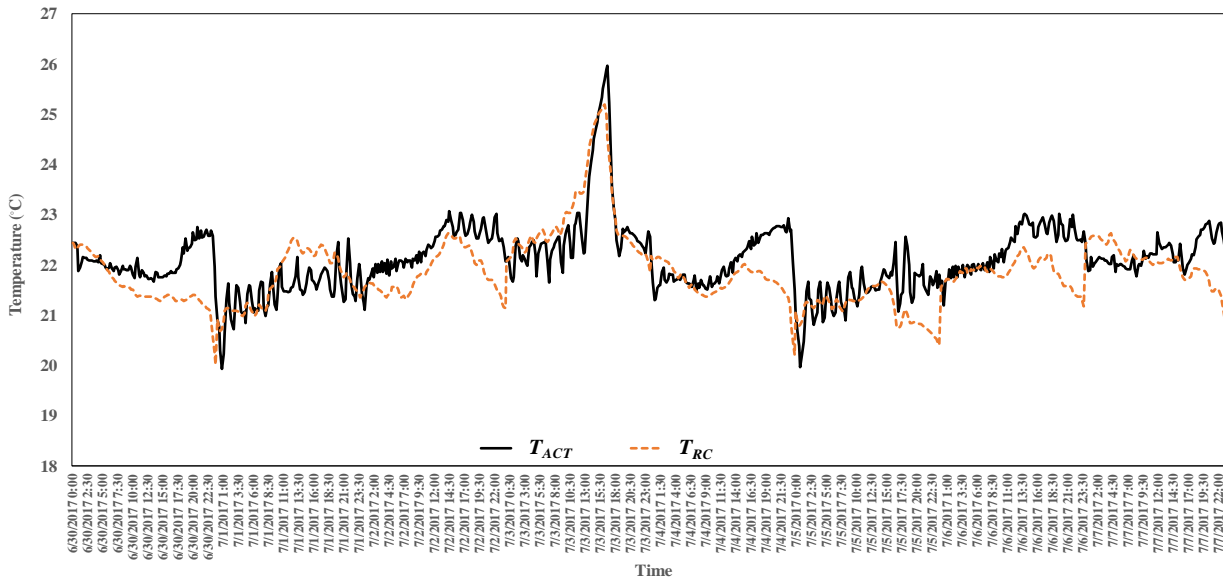

Figure 7: The predicted overall mean indoor temperature by RC model (Jun 30 to Jul 7, 2017)

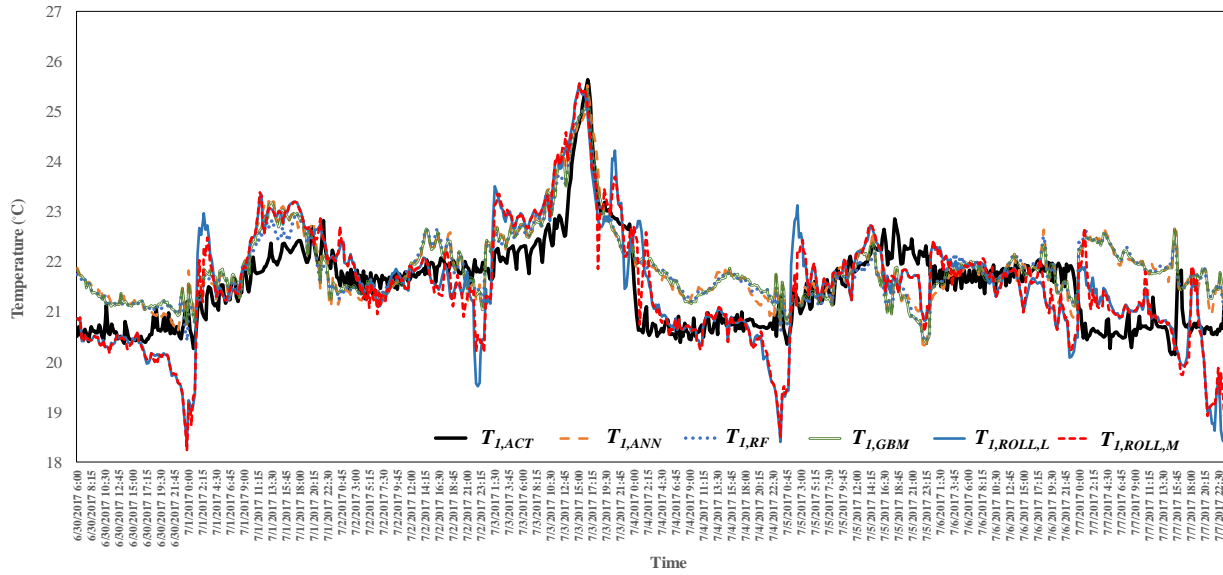

Figure 8: The predicted  $T_1$  comparison (Jun 30 to Jul 7,2017)

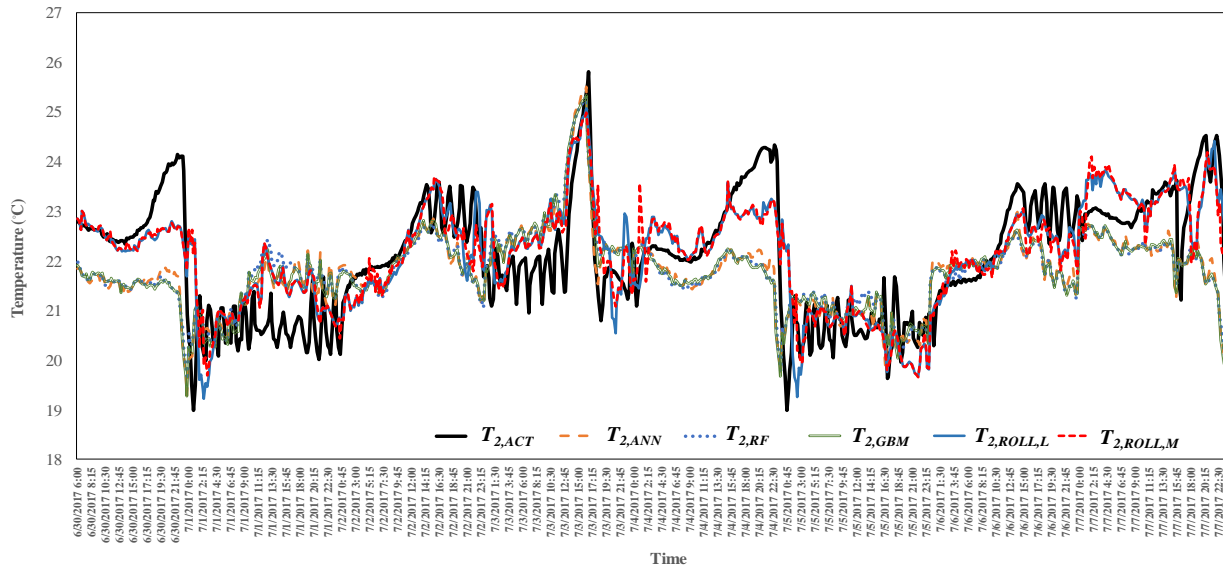

Figure 9: The predicted  $T_2$  comparison (Jun 30 to Jul 7,2017)

Table 3: Overall prediction performance of developed hybrid modeling approach

DeltT prediction method	Predicted average temperature in respective floors	MAE	RMSE
ANN	$T_1$	0.595	0.751
	$T_2$	0.822	1.046
RF	$T_1$	0.581	0.740
	$T_2$	0.865	1.090
GBM	$T_1$	0.593	0.751
	$T_2$	0.841	1.080
Rolling horizon (4 inputs)	$T_1$	0.563	0.756
	$T_2$	0.553	0.736
Rolling horizon (6 inputs)	$T_1$	0.529	0.705
	$T_2$	0.556	0.741

## 5. Conclusions

In this research, a simplified regression building modelling method is proposed to predict average indoor temperature in separate floors of typical detached residential house in U.S. A rolling horizon model, which includes online adaptive correction component, is proposed to predict the temperature difference between downstairs and upstairs. A RC model is used to predict the overall mean indoor air temperature. The validation is conducted by comparing the predicted results with the results from data-mining based models as well as measured data from a real typical detached two-floor house. The results show that the developed method has the best prediction performance in predicting the downstairs and upstairs temperatures.

## REFERENCES

- ASHRAE. *ASHRAE Handbook: Fundamentals (SI Edition)*. Atlanta, GA: American Society of Heating, Refrigerating and Air-conditioning Engineers; 2013.
- Cole, W.J., Powell, K.M., Hale, E.T. & Edgar, T.F. (2014). Reduced-order residential home modeling for model predictive control. *Energy and Buildings*, 74, 69-77.
- Cui, B., Gao, D.C., Xiao, F. & Wang, S. (2017). Model-based optimal design of active cool thermal energy storage for maximal life-cycle cost saving from demand management in commercial buildings. *Applied Energy*, 201, 382-396.
- Cui, B., Gao, D. C., Wang, S., & Xue, X. (2015). Effectiveness and life-cycle cost-benefit analysis of active cold storages for building demand management for smart grid applications. *Applied energy*, 147, 523-535.
- Dong, B., Li, Z., Rahman, S.M. & Vega, R. (2016). A hybrid model approach for forecasting future residential electricity consumption. *Energy and Buildings*, 117, 341-351.
- Edwards, R.E., New, J. & Parker, L.E. (2012). Predicting future hourly residential electrical consumption: A machine learning case study. *Energy and Buildings*, 49, 591-603.
- International Energy Conservation Codes (IECC) – 2006 IECC Prescriptive Requirements-Available at: [https://www.energycodes.gov/sites/default/files/documents/ta\\_2006\\_iecc\\_prescriptive\\_requirements.pdf](https://www.energycodes.gov/sites/default/files/documents/ta_2006_iecc_prescriptive_requirements.pdf).
- Kim, D., Cai, J., Ariyur, K.B. & Braun, J.E. (2016). System identification for building thermal systems under the presence of unmeasured disturbances in closed loop operation: Lumped disturbance modeling approach. *Building and Environment*, 107, 169-180.
- Kusiak, A., Li, M. & Tang, F. (2010). Modeling and optimization of HVAC energy consumption. *Applied Energy*, 87(10), 3092-3102.
- Motegi, N., Piette M.A., Watson, D.S., Kiliccote, S. & Xu P. (2005). Introduction to Commercial Building Control Strategies and Techniques for Demand Response. *Lawrence Berkeley National Laboratory LBNL-59975*.
- National Oceanic and Atmospheric Administration (NOAA). Solar Calculation Details – Available at: <https://www.esrl.noaa.gov/gmd/grad/solcalc/calcdetails.html>.

## ACKNOWLEDGEMENT

The research presented in this paper was funded by the United States Department of Energy, Energy Efficiency and Renewable Energy Office, Building Technology Office under the grid modernization program.