

Reconstruction of Room D Closure History

Benjamin Reedlunn
Computational Solid Mechanics
Sandia National Laboratories

Background

Room B and D

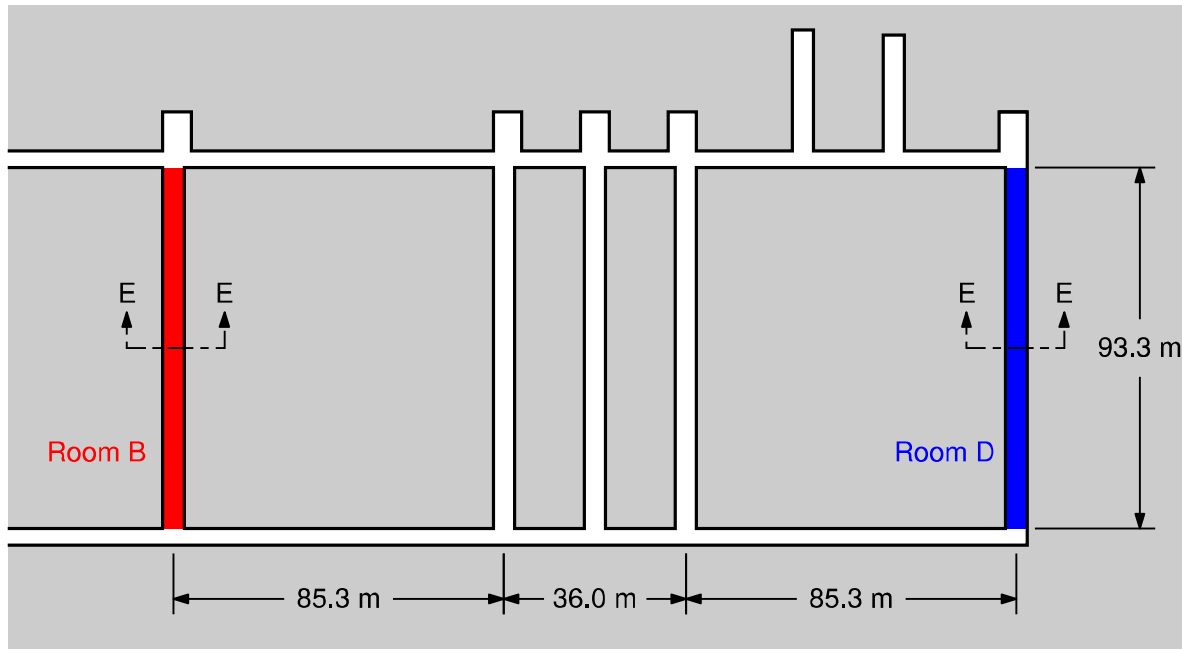

Plan View

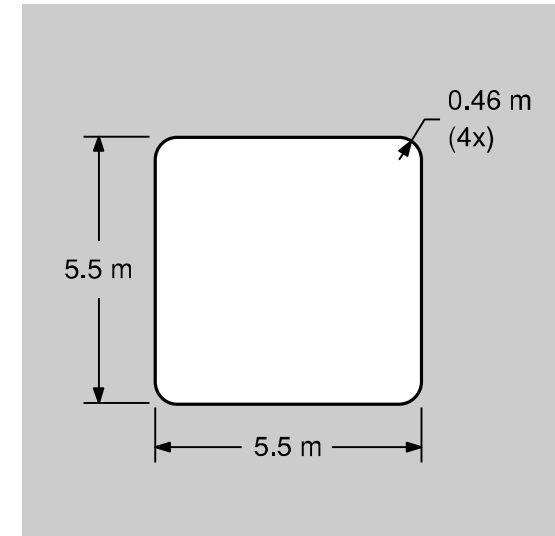

Section E-E

Confusion about Room B and Room D Closure

Sandia

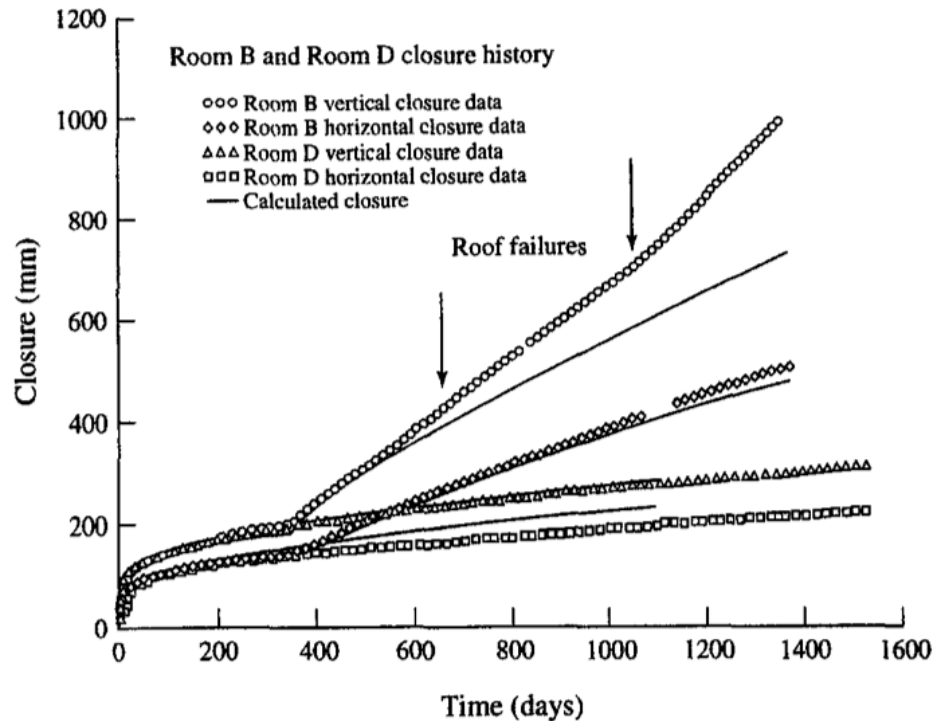

Munson, D. 1997. Constitutive model of creep in rock salt applied to underground room closure. International Journal of Rock Mechanics and Mining Sciences. 34 (2) pg. 233-247

Joint Project III

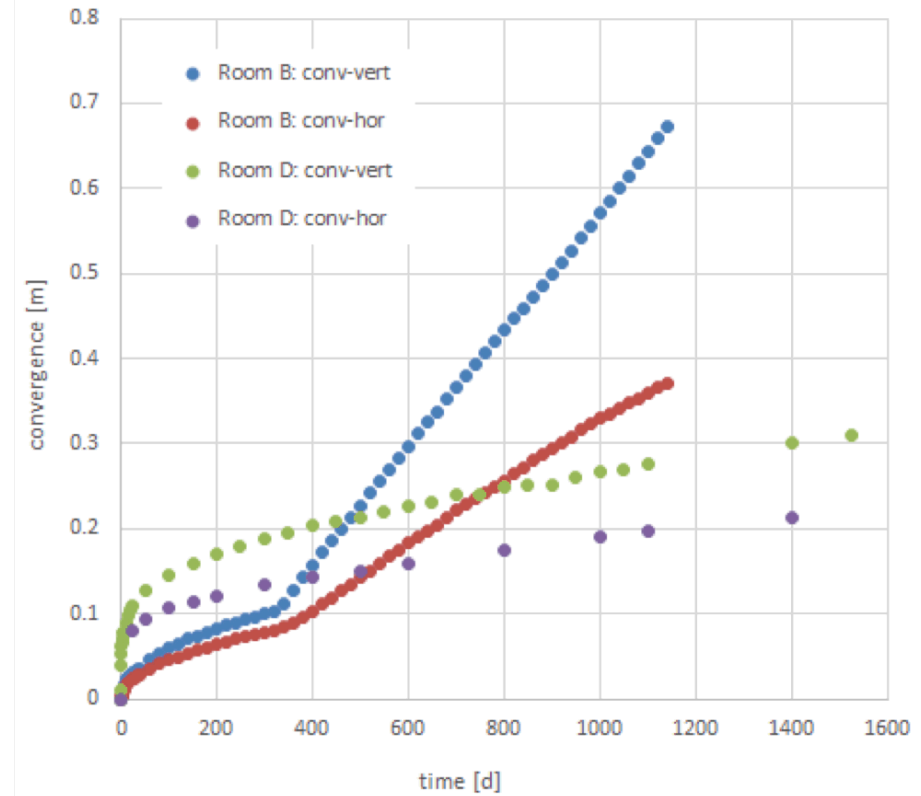

Hampel, A., March 2016, Personal Communication

Potential Source of Confusion

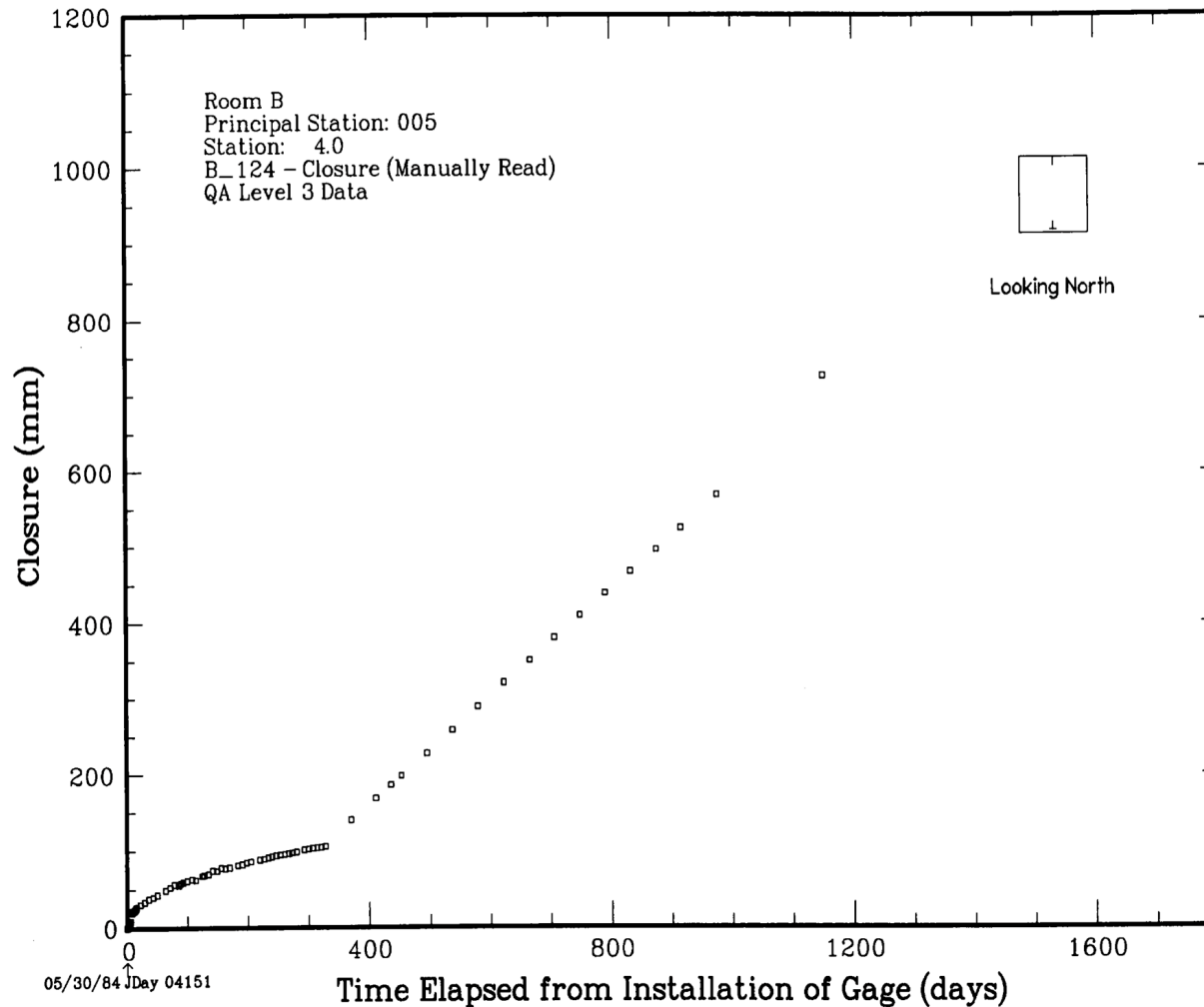

Munson, Darrell E., et al. 1990. Overtest for Simulated Defense High-Level Waste (Room B): In Situ Data Report (May 1984-February 1988). Waste Isolation Pilot Plant (WIPP) Thermal/Structural Interactions Program. SAND89-2671

Potential Source of Confusion

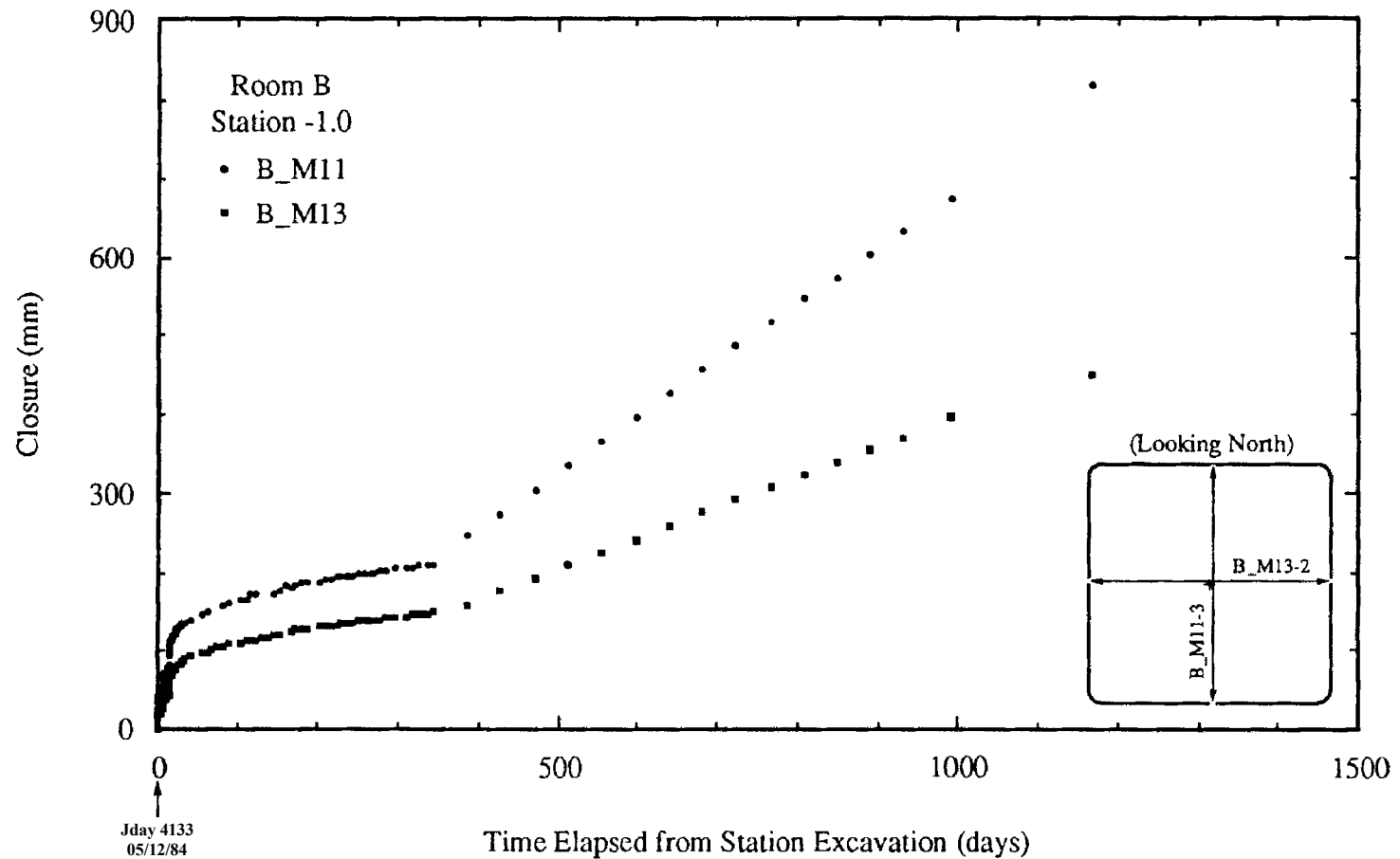

Munson, Darrell E., et al. 1992. Multipass Mining Sequence Room Closures: in situ Data Report. Waste Isolation Pilot Plant (WIPP) Thermal/Structural Interactions Program. SAND87-2687

Confusion about Room B and Room D Closure

Sandia

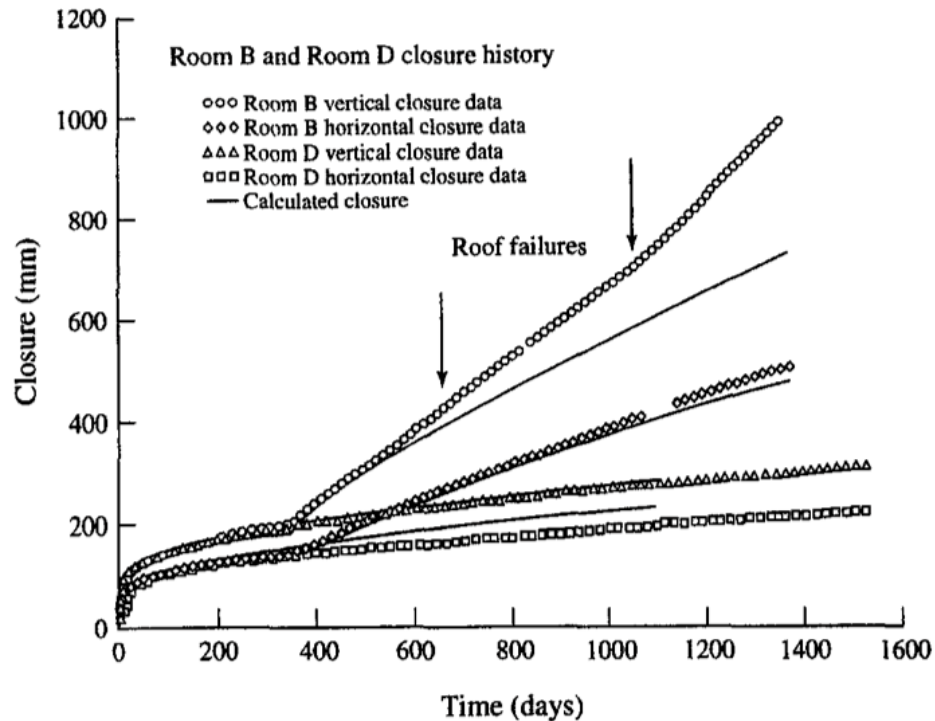

Munson, D. 1997. Constitutive model of creep in rock salt applied to underground room closure. *International Journal of Rock Mechanics and Mining Sciences*. 34 (2) pg. 233-247

Joint Project III

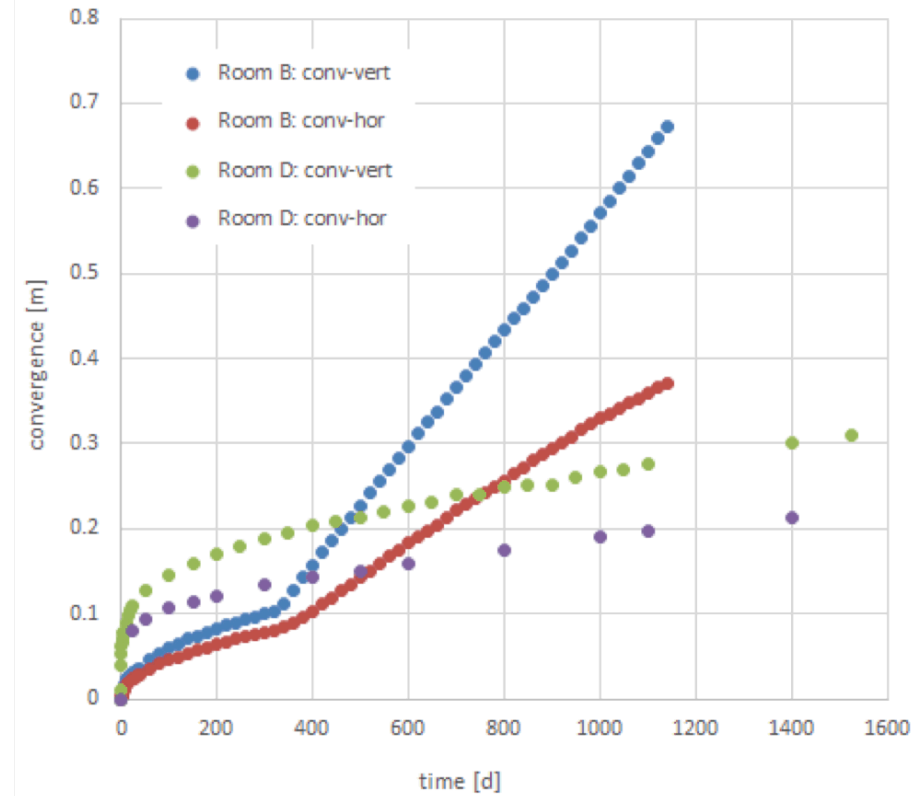

Hampel, A., March 2016, Personal Communication

Mining Face Position

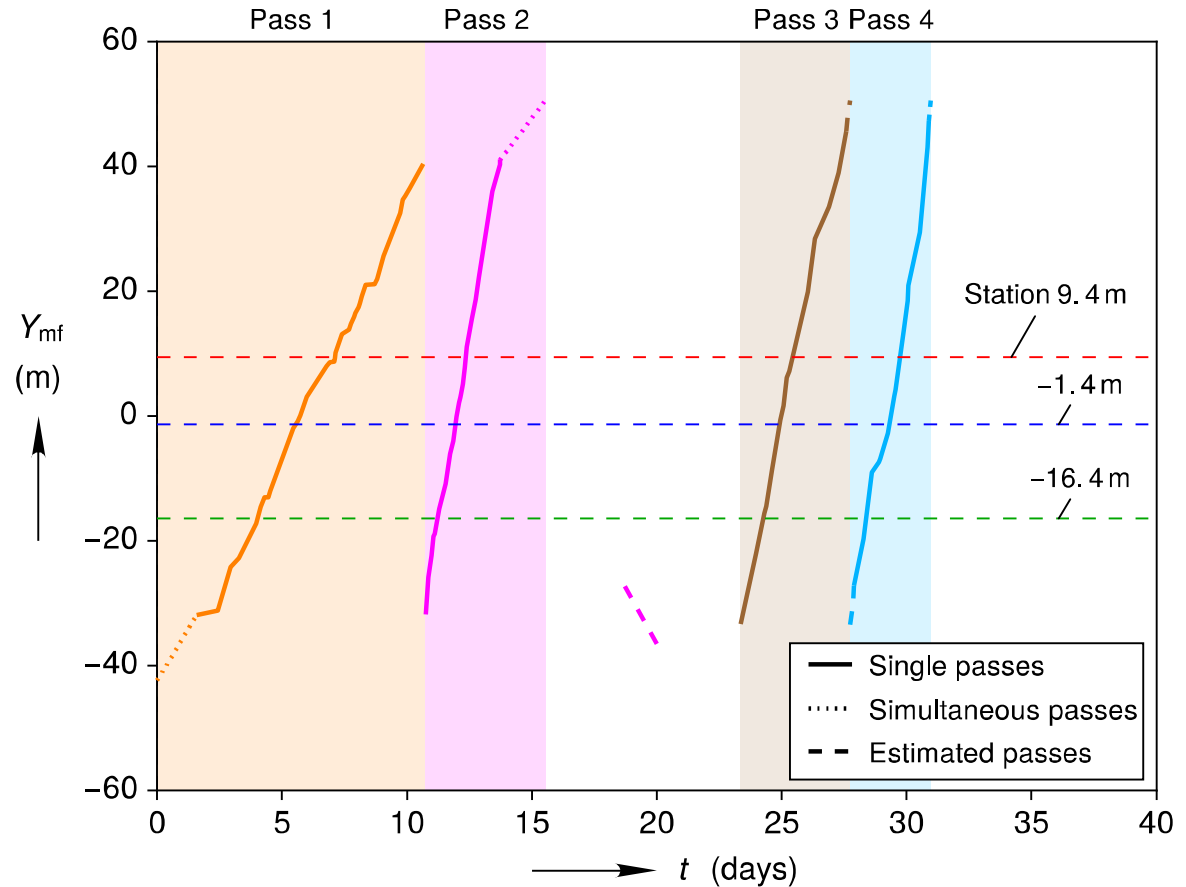
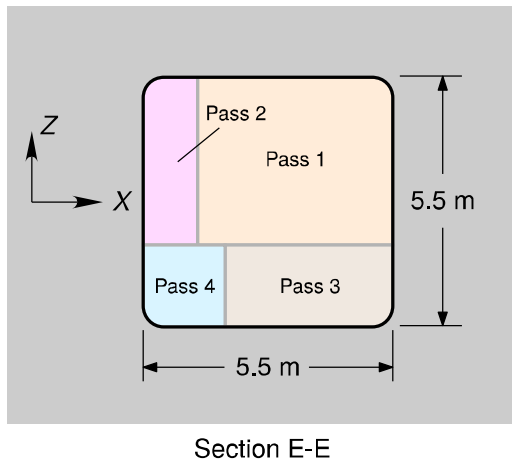
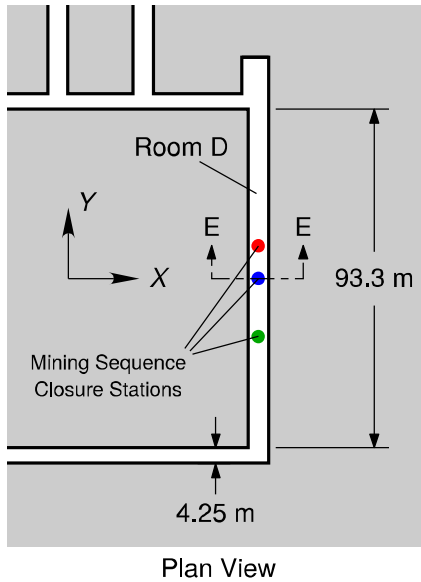

Reconstruction Process

Handwritten Data Sheets

- Digital records of closure were not found

- Room D handwritten data sheets were located
 - 545 pages painstakingly digitized by Laurie Williams
 - Outliers identified
 - Numerous shifts explained

- Still searching for Room B data sheets

Example Data Sheet

WIPP
WASTE ISOLATION
PILOT PLANT

 Sandia National Laboratories

MINING SEQUENCE CLOSURE GAGE DATA

STATION 150' 4/e/84 ROOM D

S. BALONE & D. JONES Graveyard SINCO #1900

PAIRED POINTS	READING	DATE	TIME	PASS NUMBER	DISTANCE TO FACE
1A-1B	10'6" + 1595	4/6/84	0713	1 & 2	mine tunnels EAST rib
1G-1H	10'6" + 1.014	↓	0710	complete	
2C-1D'	16'10" + 0.472	↓	0654	↓	Installed
2E-1F'	16'6" + 0.817	↓	0658	↓	new points in east rib at 1-D' & 1-F'

Station -1.4 m Horizontal Closure

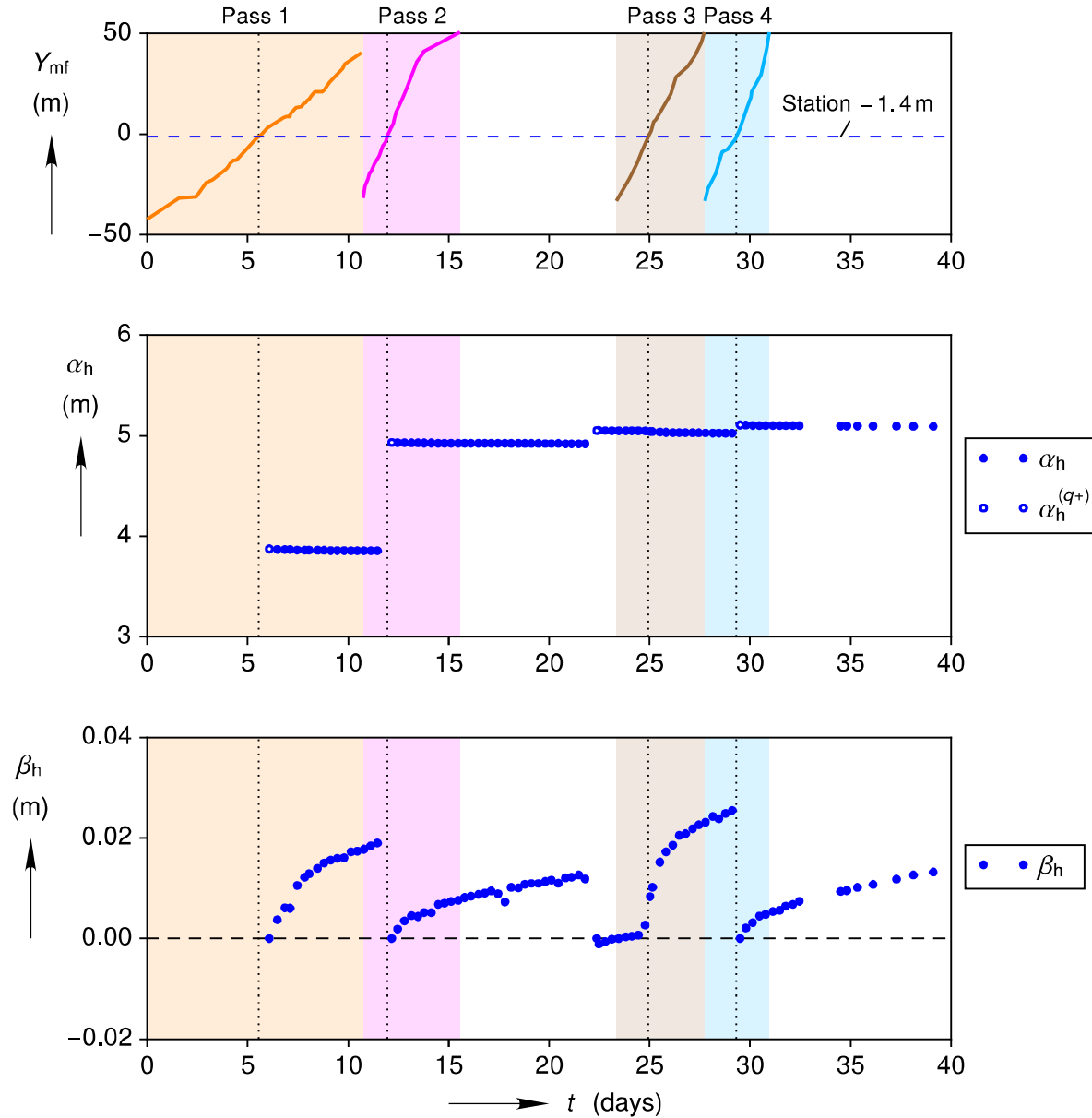

Splicing

Kelvin-Voigt & Dashpot

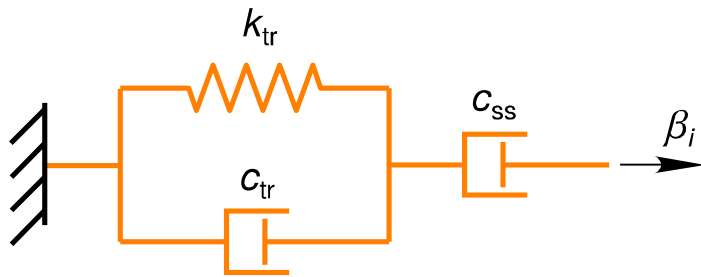

$$\beta_i = \frac{F}{k_{tr}} \left\{ 1 - \exp \left[-\frac{k_{tr}}{c_{tr}} (t - t^{(q)}) \right] \right\} + \frac{F}{c_{ss}} (t - t^{(q)})$$

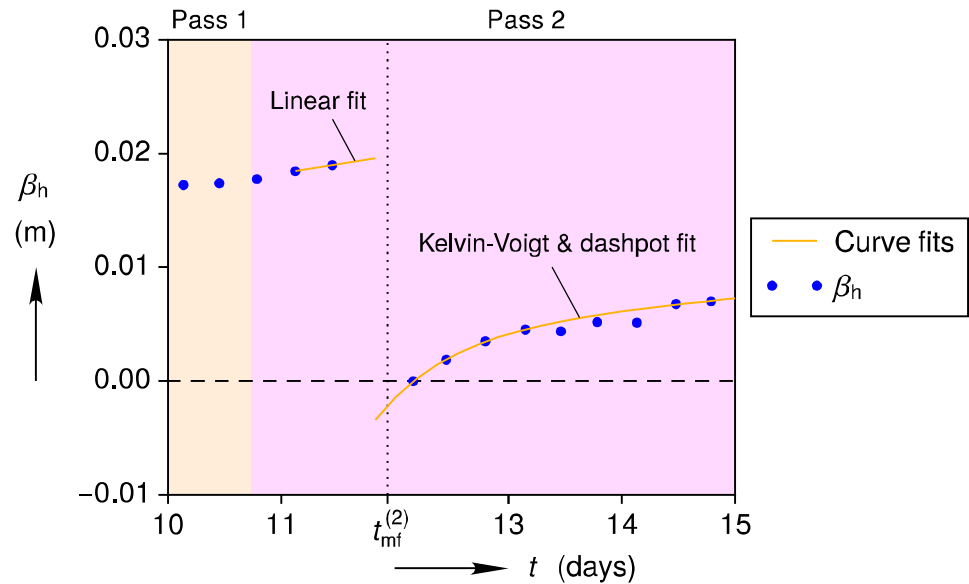

Splicing

Kelvin-Voigt & Dashpot

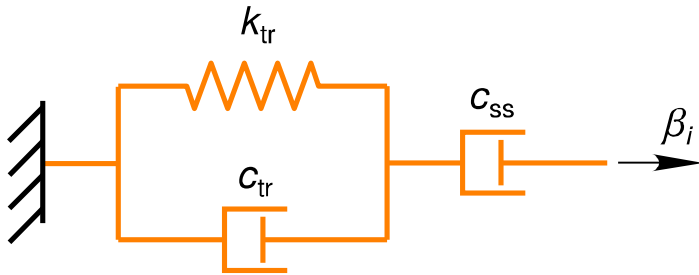

$$\beta_i = \frac{F}{k_{tr}} \left\{ 1 - \exp\left[-\frac{k_{tr}}{c_{tr}}(t - t^{(q)})\right] \right\} + \frac{F}{c_{ss}} (t - t^{(q)})$$

$d^{(q+)}$ = distance to mining face at $t^{(q+)}$

$$t^{(q)} = t^{(q+)} - \frac{d^{(q+)}}{\dot{\gamma}_{mf}^{(q)}}$$

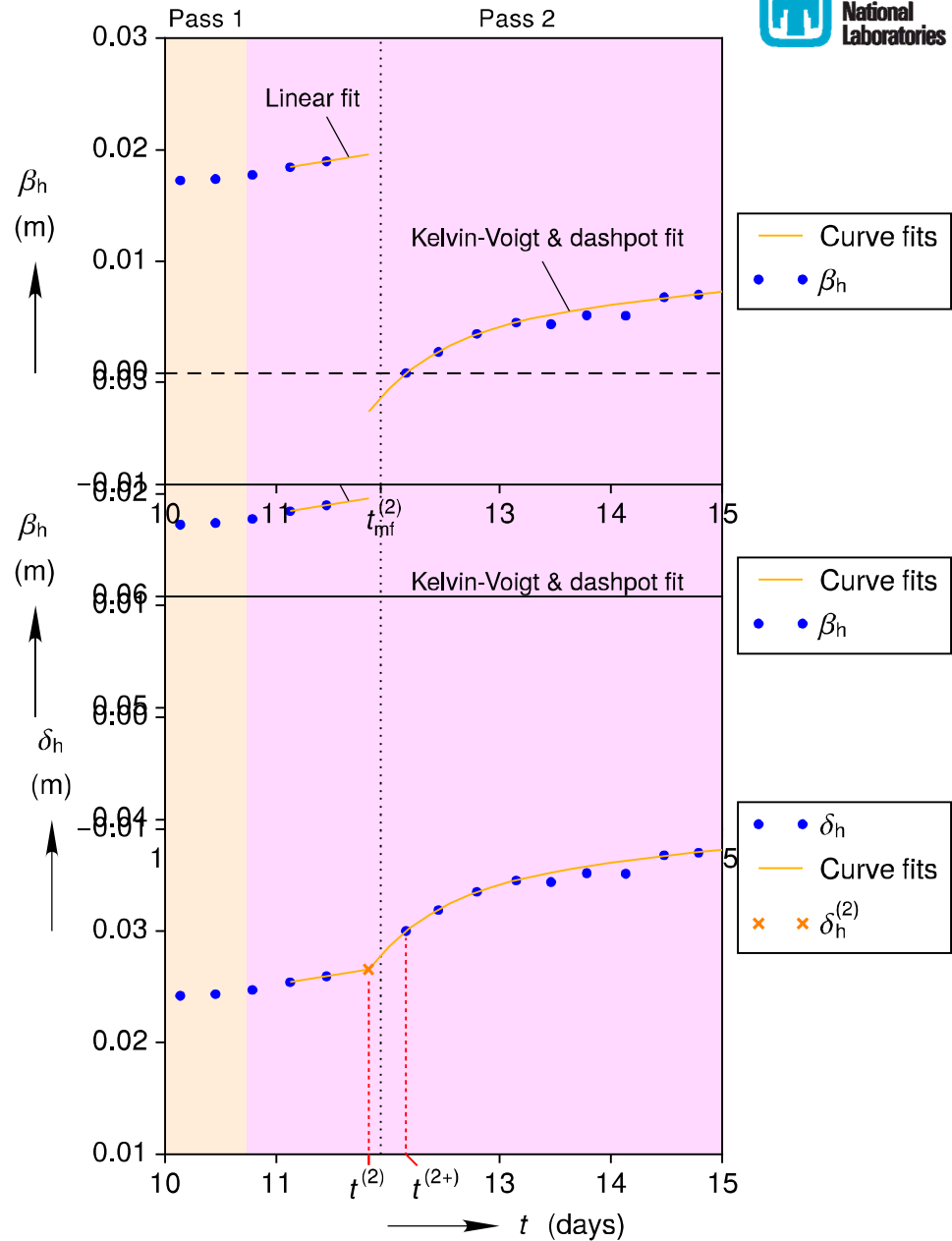

Splicing

Kelvin-Voigt & Dashpot

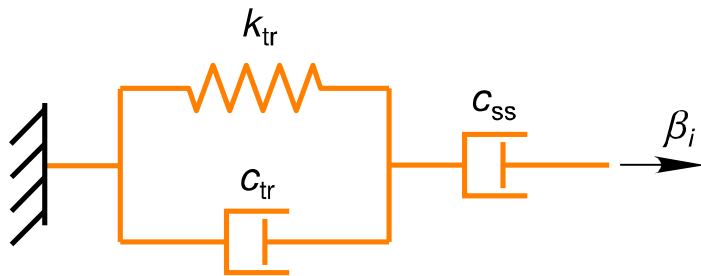

$$\beta_i = \frac{F}{k_{tr}} \left\{ 1 - \exp \left[-\frac{k_{tr}}{c_{tr}} (t - t^{(q)}) \right] \right\} + \frac{F}{c_{ss}} (t - t^{(q)})$$

Mined Out Time

$d^{(q+)}$ = distance to mining face at $t^{(q+)}$

$$t^{(q)} = t^{(q+)} - \frac{d^{(q+)}}{\dot{\gamma}_{mf}^{(q)}}$$

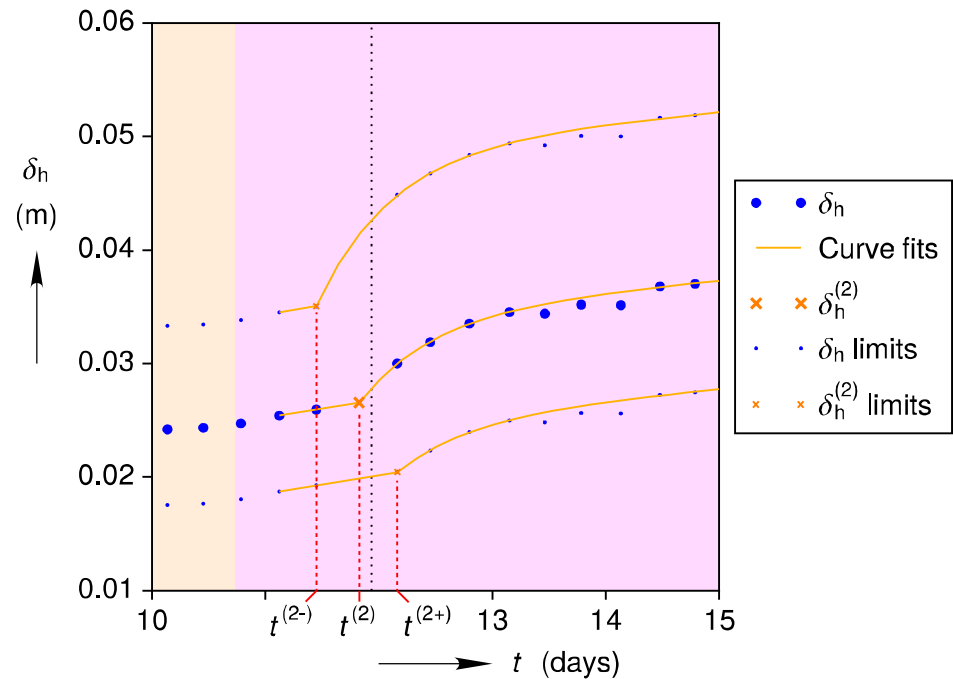
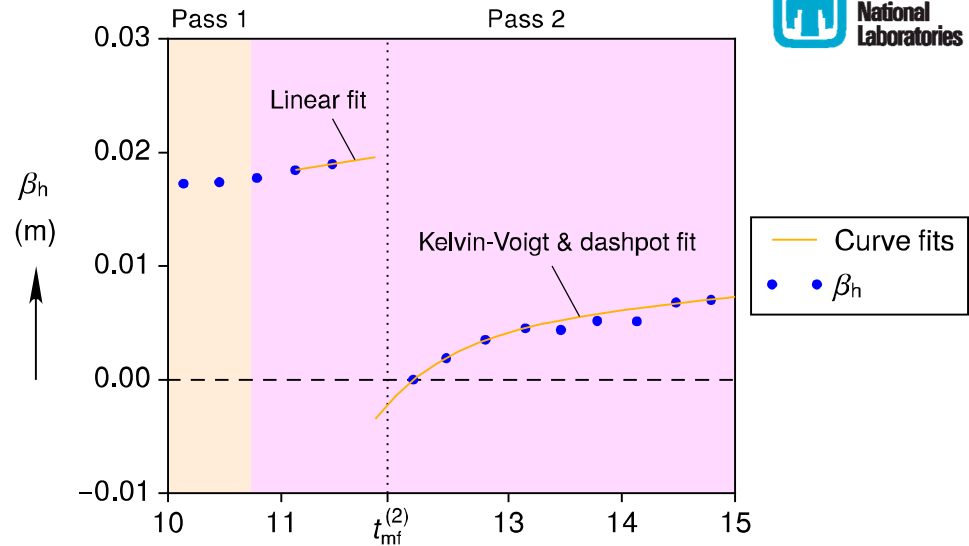

Station -1.4 m Horizontal Closure

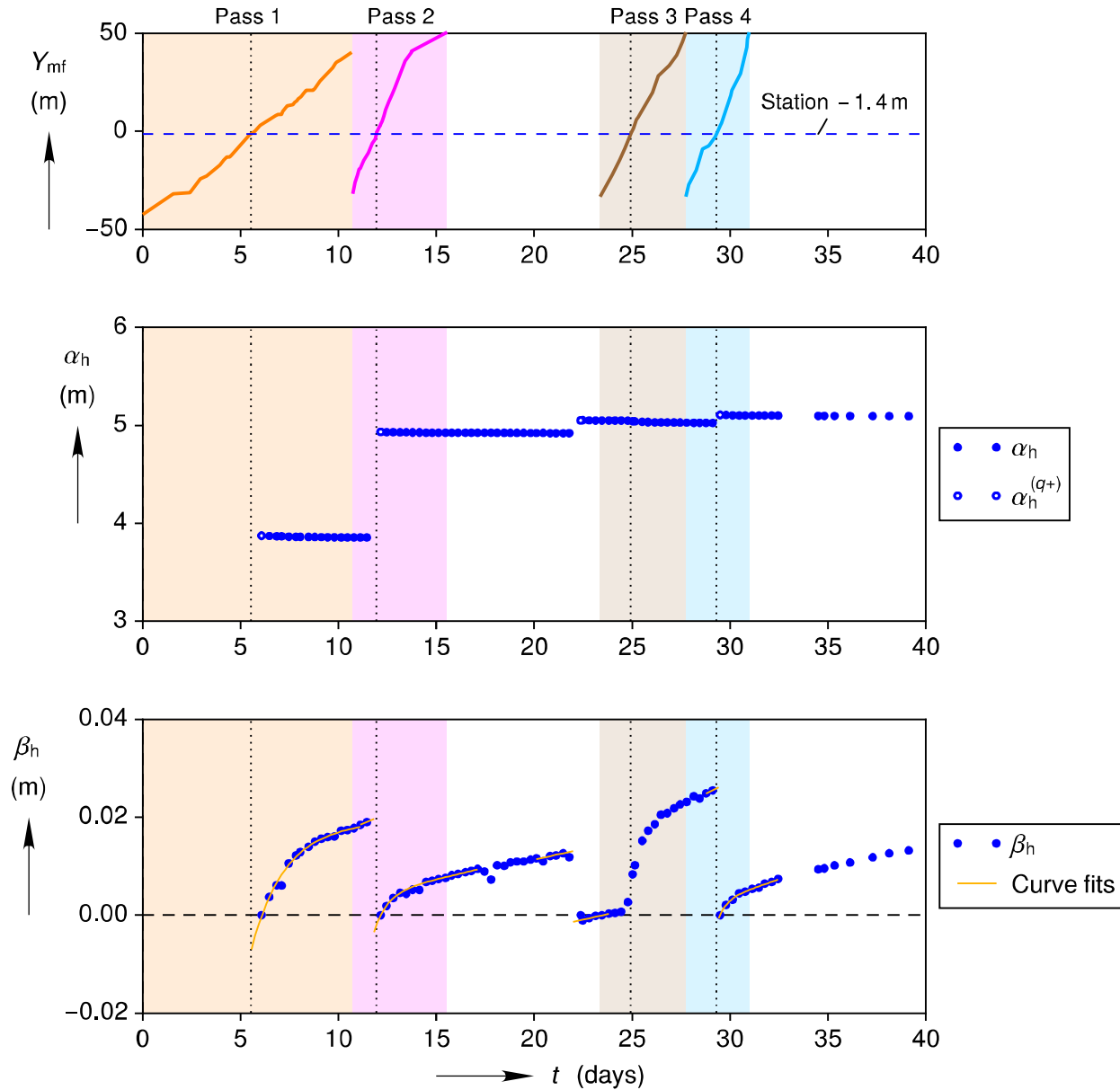

Station -1.4 m Horizontal Closure

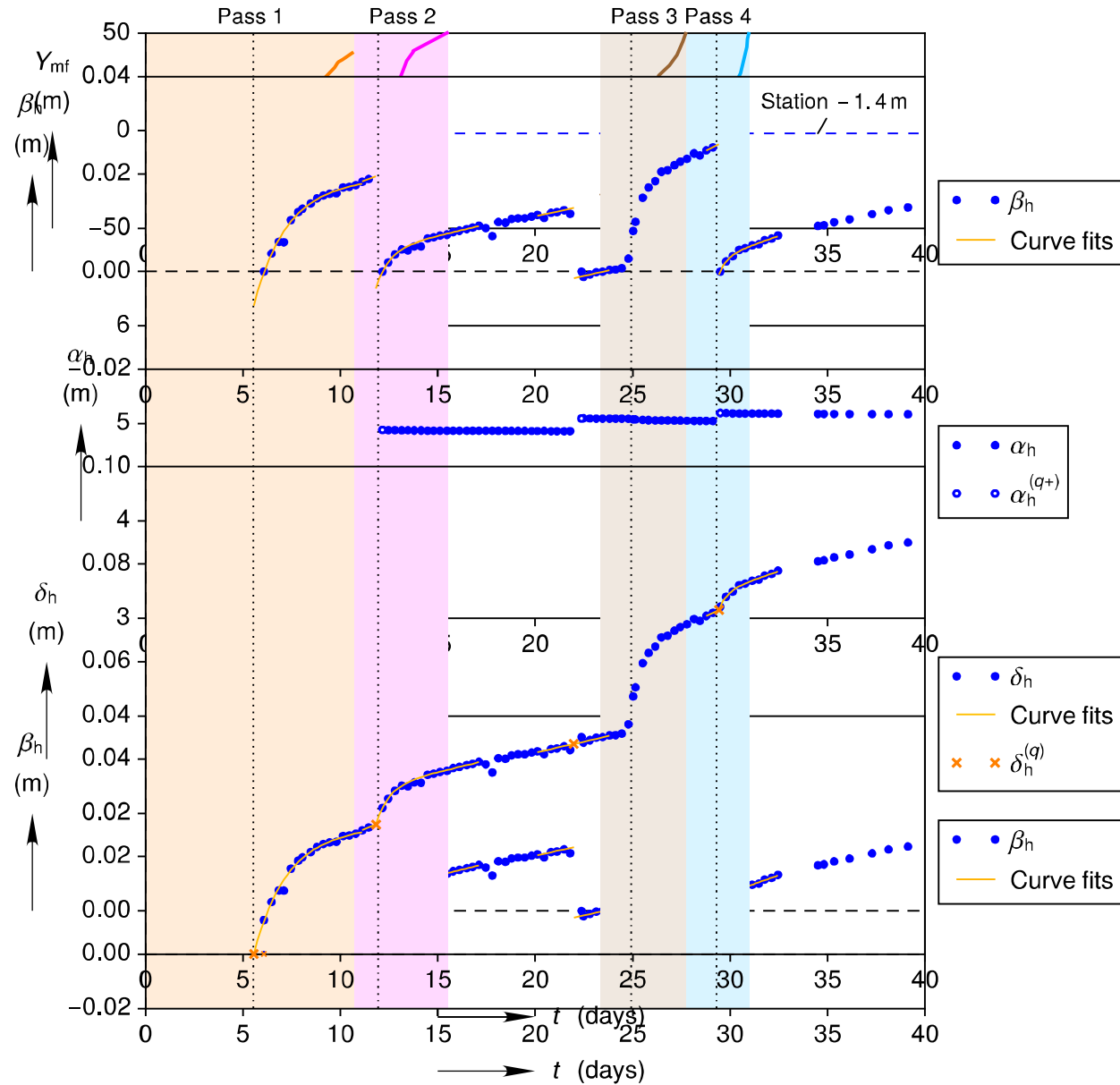

Station -1.4 m Horizontal Closure

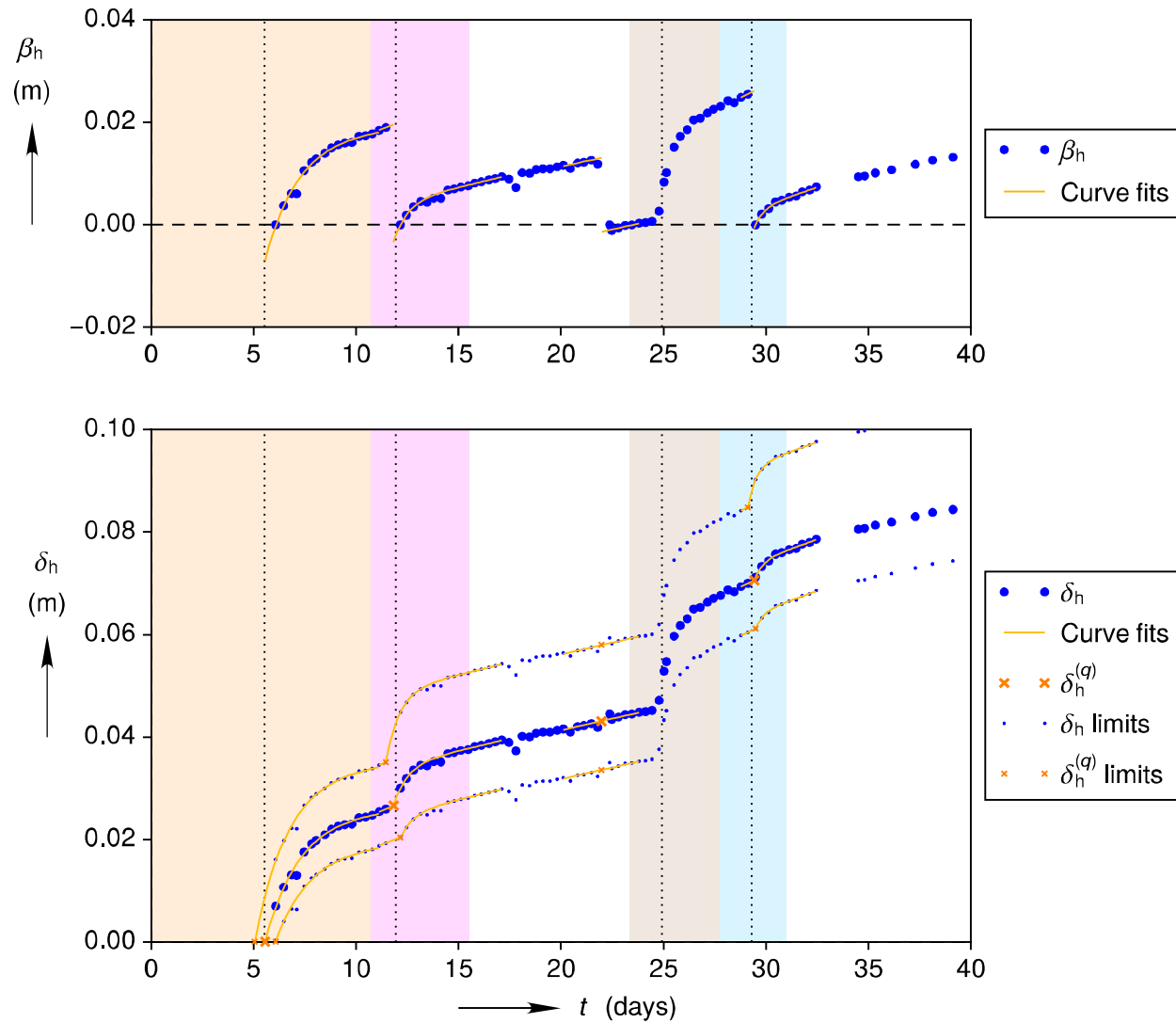

Station -1.4 m Horizontal Closure

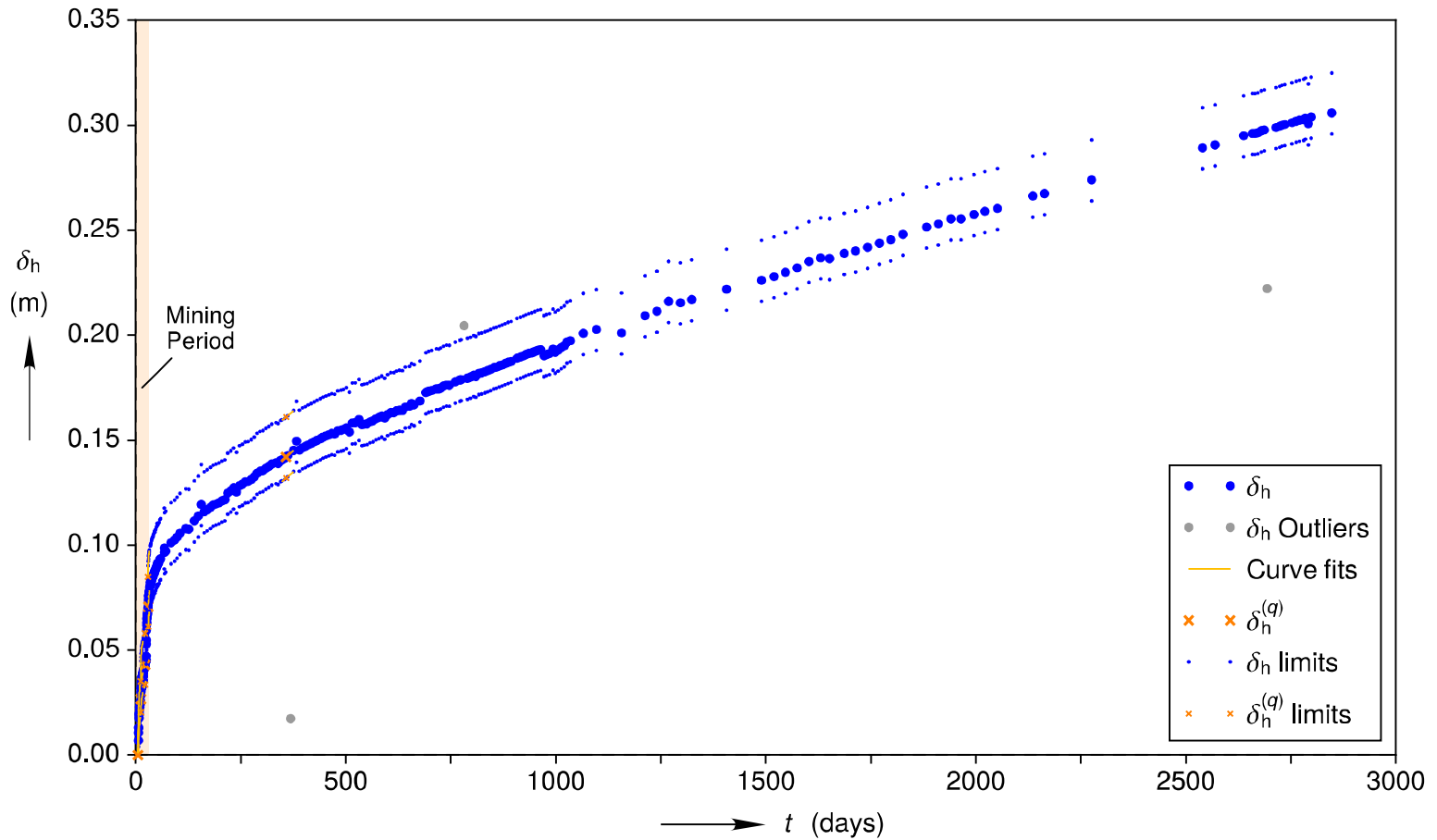

Station -1.4 m Vertical Closure

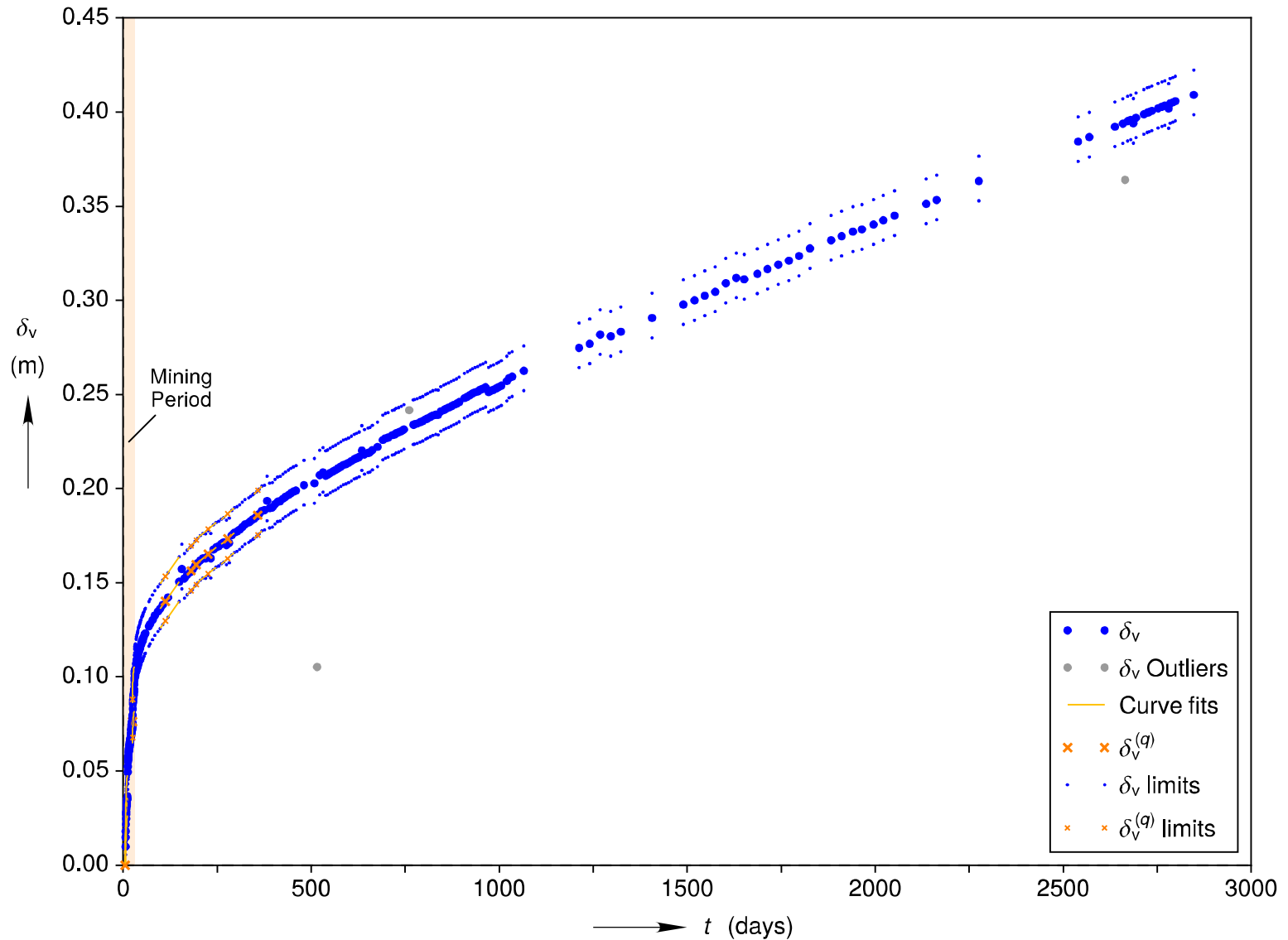

Comparisons

Compare Stations: Horizontal Closure

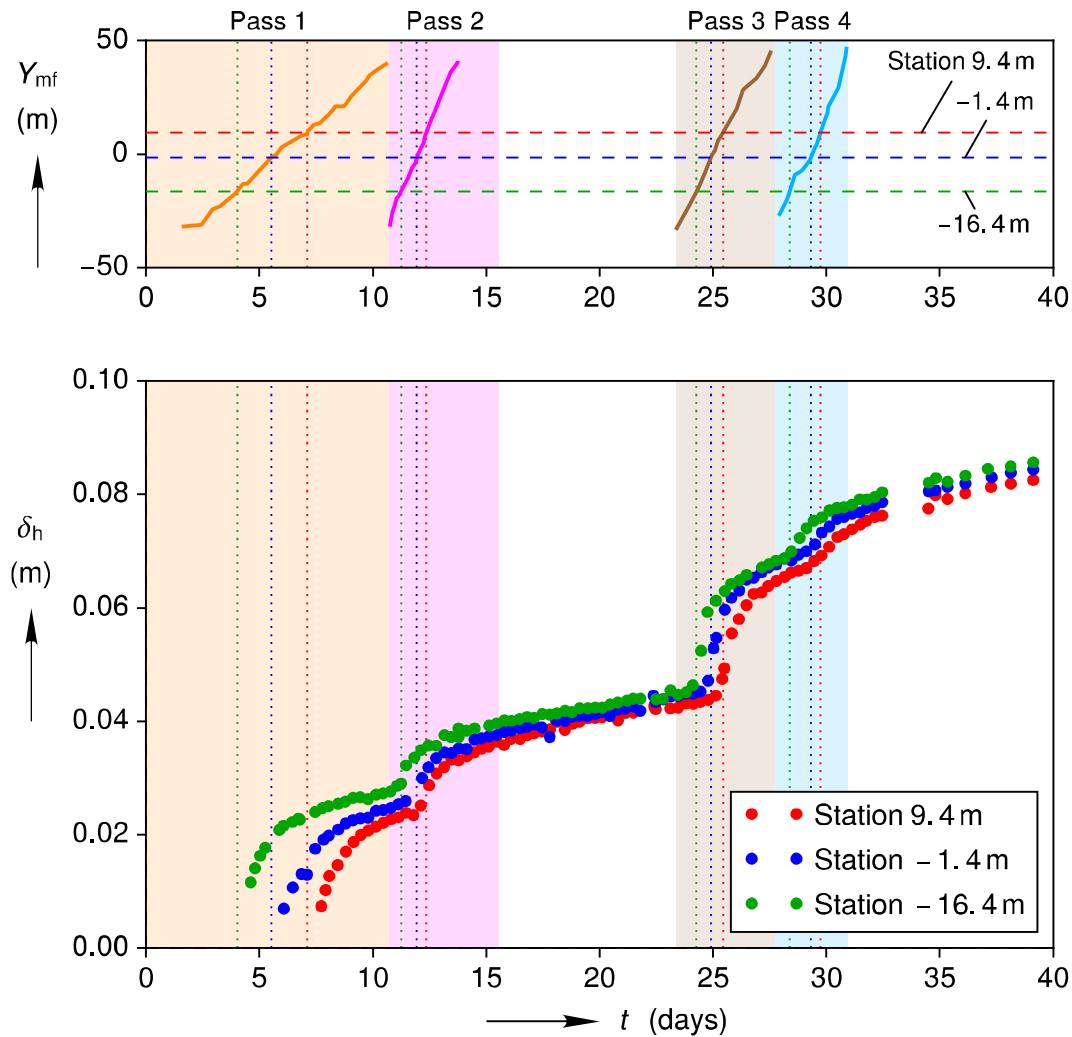

Compare Stations: Vertical Closure

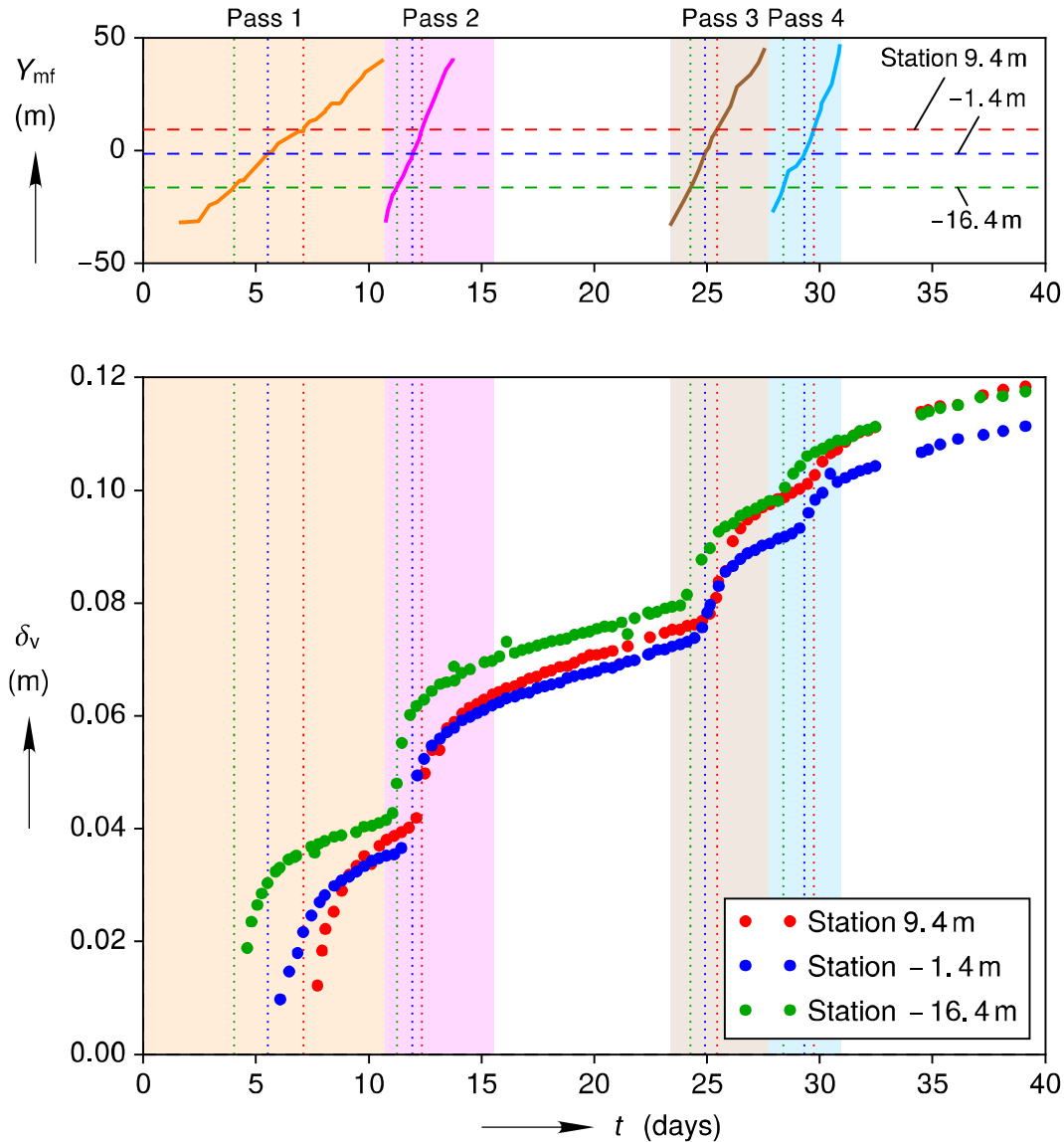

Compare Stations: Horizontal Closure

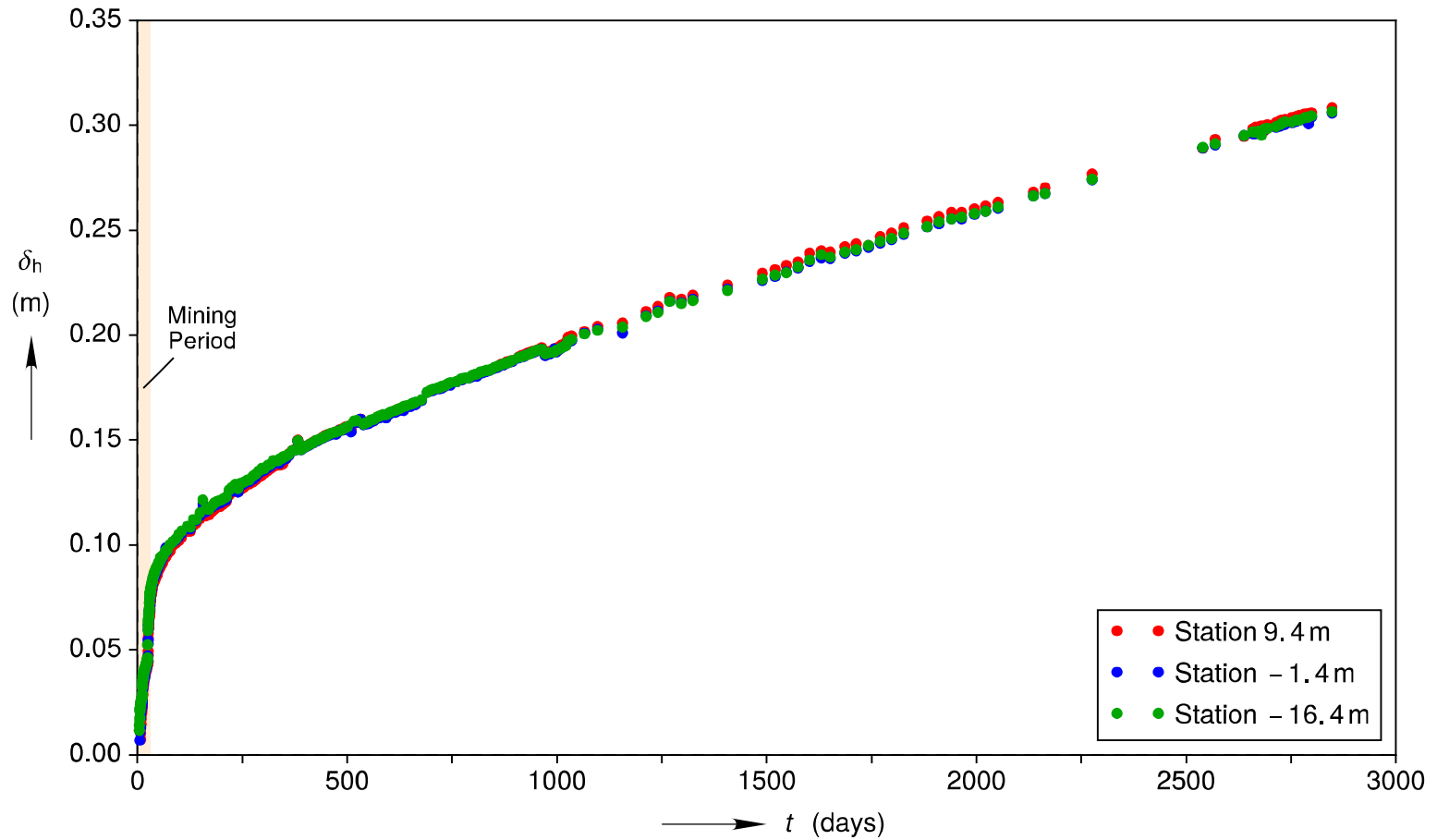

Compare Stations: Vertical Closure

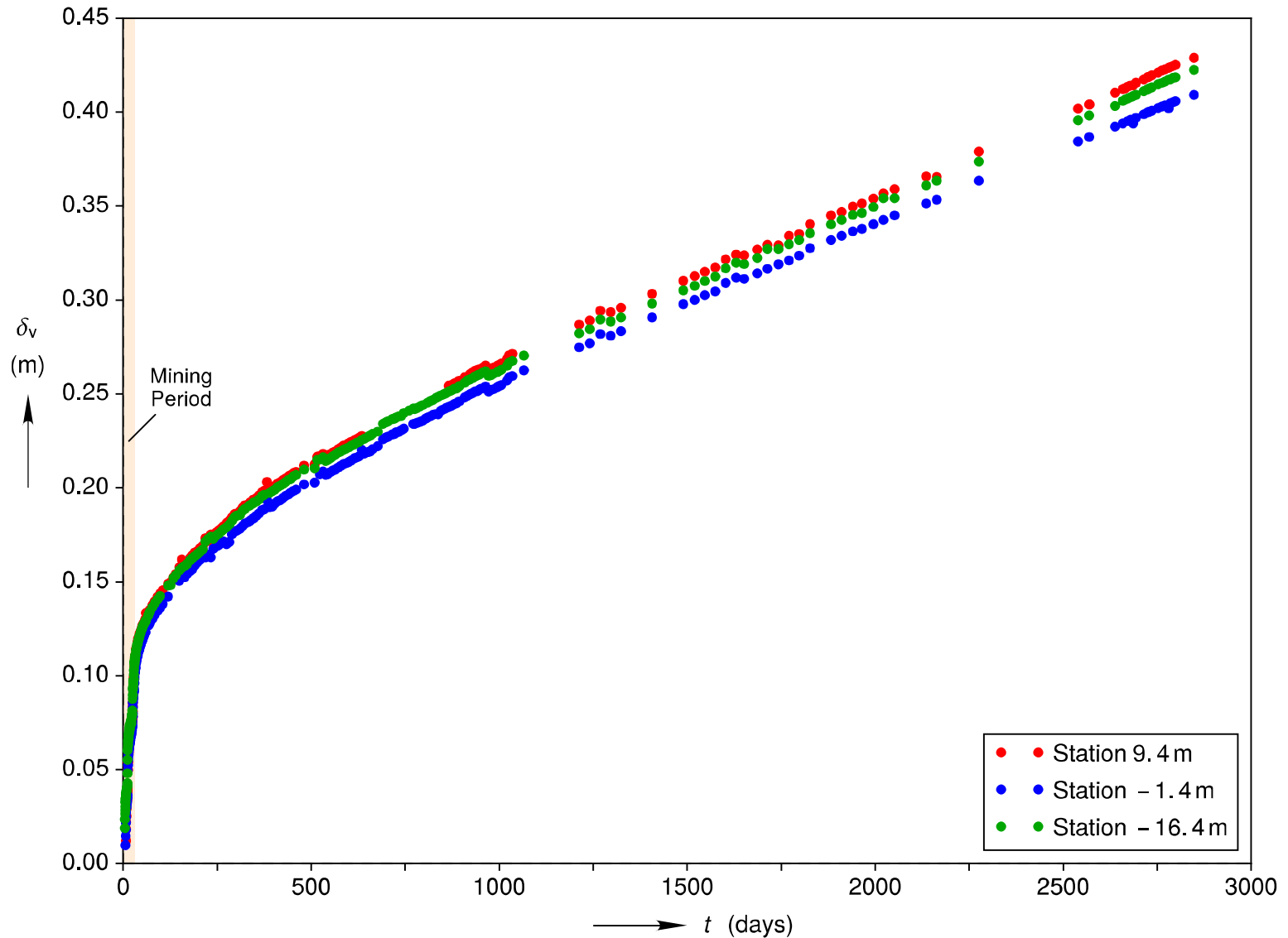

Compare Against Legacy Constructions

Horizontal Closure

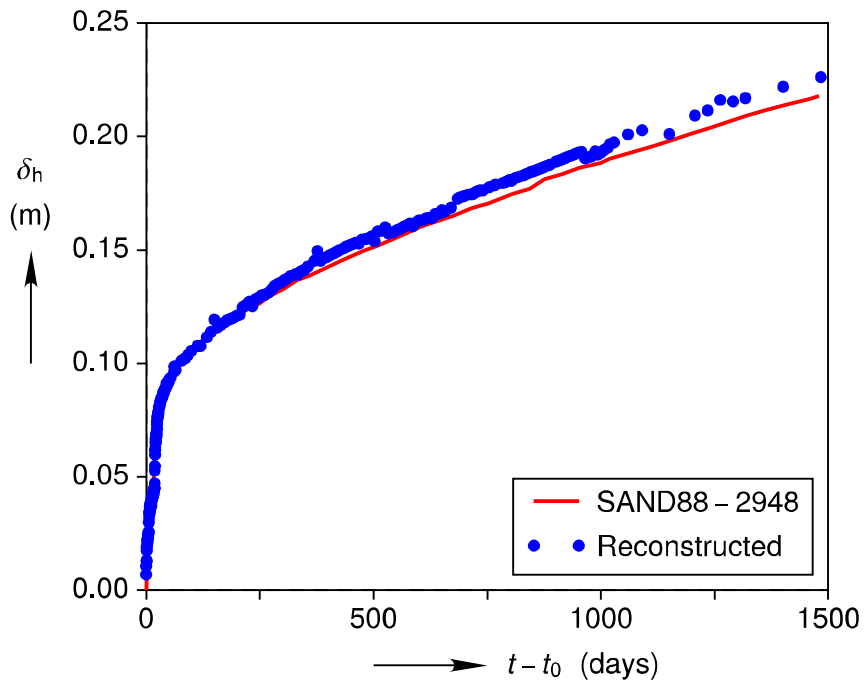

Vertical Closure

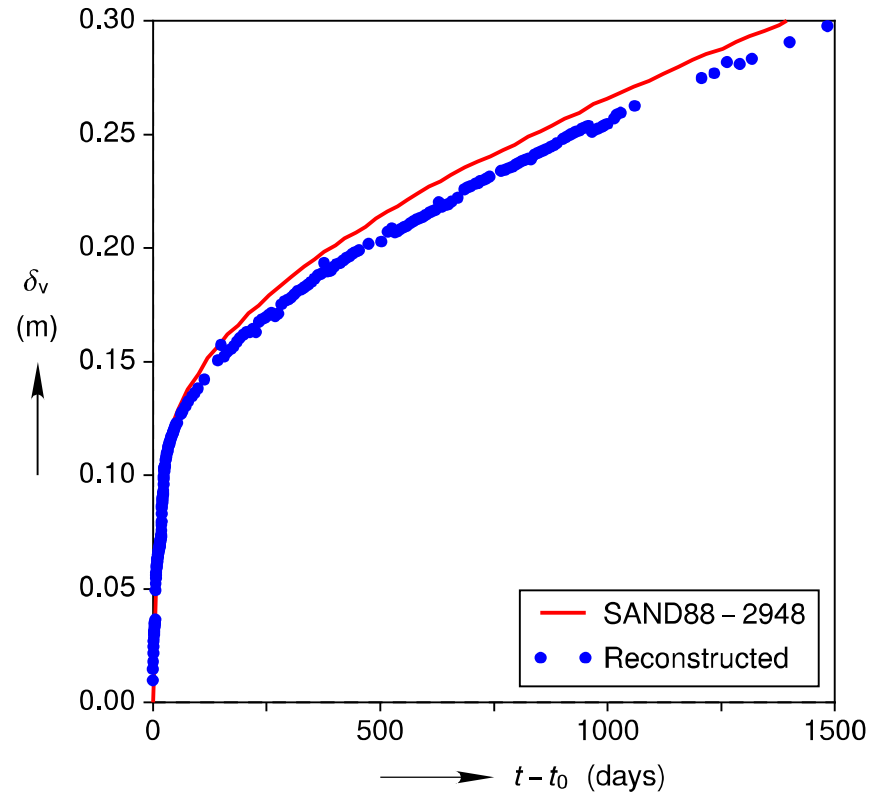

- Confusion regarding Room B vs. Room D closure appears to be due to:
 - Closure gage results reported with multiple definitions of $t = 0$
 - Closure measurements published in separate reports and out of order
- Uncertainty associated with mining out Room D closure stations is roughly $\pm 5\%$ of nominal closure after 8 years.
- All three Room D closure stations recorded fairly similar closures, indicating that plane strain is a reasonable assumption.
- Room D reconstructed closure measurements match original constructions within $\pm 5\%$ after 4 years of closure.

Extra Slides

Potential Source of Confusion

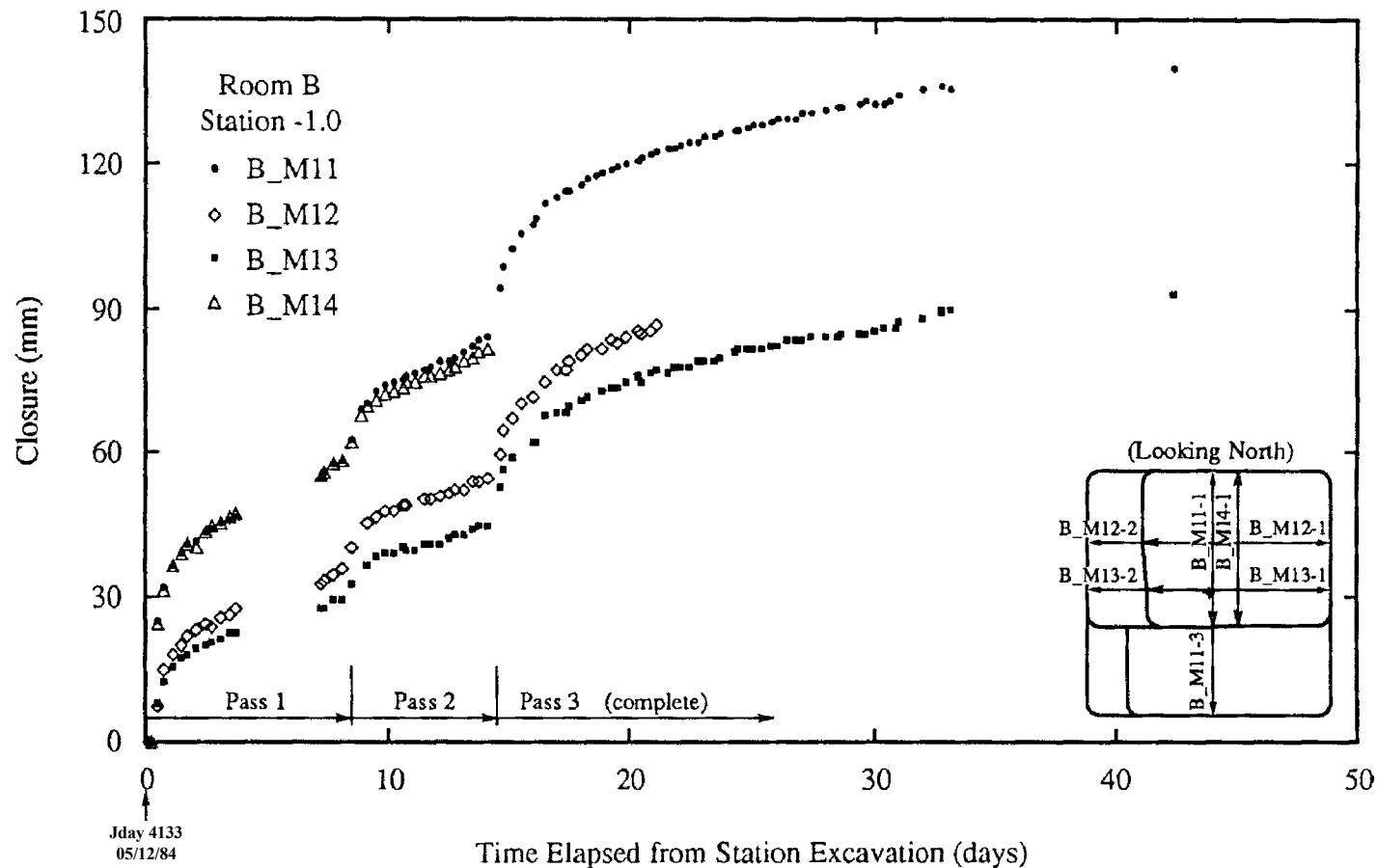

Munson, Darrell E., et al. 1992. Multipass Mining Sequence Room Closures: in situ Data Report. Waste Isolation Pilot Plant (WIPP) Thermal/Structural Interactions Program. SAND87-2687