

Active Suppression of Drilling System Vibrations For Deep Drilling

SAND2017-1834PE

LDRD Project # 165620

FY13 - FY15 Investment Area:
Energy, Climate, and Infrastructure

Principal Investigator: David Raymond (06916)

Project Manager: Doug Blankenship (06916)

LDRD Team

Mikhail Mesh (01523), Steve Buerger (06533), Jiann-Cherng Su (06916),
Steve Knudsen (06916), Avery Cashion (06916), Mark Grubelich (06916),
Elton Wright (06916), Jeff Greving (06916), Dennis King (06916), & Tim Blada (05624)

Contractors

Radigan Engineering

Prime Core Systems

Adam Foris

James Uhl

Taylor Devices

Patent Pending

The technology described herein is the subject of U.S. Patent Application No. 62219481,
entitled "DRILLING SYSTEM VIBRATION SUPPRESSION SYSTEMS AND METHODS," filed September 16, 2015.

Deep Borehole Disposal & Deep, High Value Wells

A high-reliability drilling system is needed for construction of a deep borehole disposal system to depths of 5 km in continental crystalline basement rock

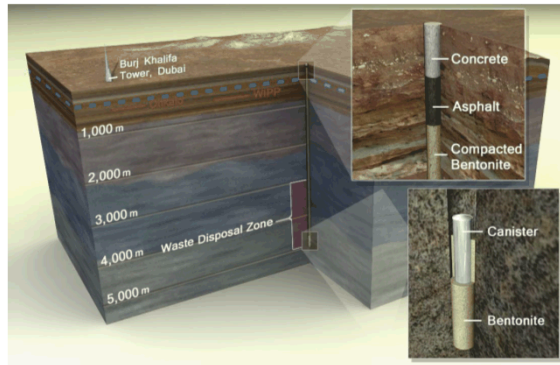

Drilling Vibrations

- Vibrations of the drillstring are of vital concern in deep holes as they increase the technical risks and final costs of well construction
 - trouble (non-productive time)
 - damaged components
 - reduced ROP (rate of penetration)
 - decreased bit and tool life

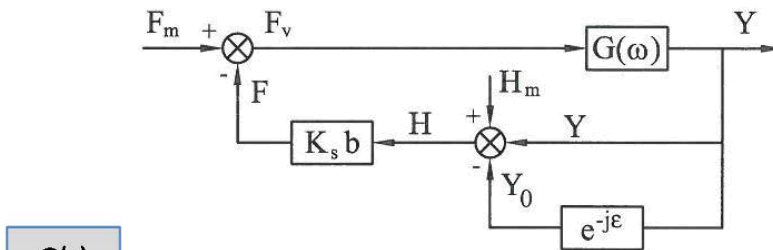

System is unstable:

- For negative real values of G
- At resonance

LDRD Technical Basis

- Stability challenged by ever-changing conditions
- Suppress vibration by controlling dynamic properties
- Autonomous
- Contrasts with conventional approach
- Technical basis is Creative / Innovative R&D

Substructured Dynamic Representations

- Represent complex dynamic models in form suitable for application of control development tools (Matlab, Simulink, block diagrams, port functions)
- Easily change dynamics of a subsystem without having to run new FEA for entire system

Drillstring Substructuring

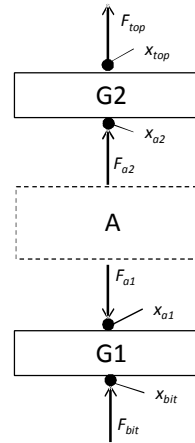

$$\begin{bmatrix} \dot{x}_{top} \\ \dot{x}_{a2} \end{bmatrix} = \begin{bmatrix} Y_{G2_11} & Y_{G2_12} \\ Y_{G2_21} & Y_{G2_22} \end{bmatrix} \begin{bmatrix} F_{top} \\ F_{a2} \end{bmatrix}$$

$$\begin{bmatrix} F_{a1} \\ F_{a2} \end{bmatrix} = \begin{bmatrix} Z_{A_11} & Z_{A_12} \\ Z_{A_21} & Z_{A_22} \end{bmatrix} \begin{bmatrix} \dot{x}_{a1} \\ \dot{x}_{a2} \end{bmatrix}$$

$$\begin{bmatrix} \dot{x}_{bit} \\ \dot{x}_{a1} \end{bmatrix} = \begin{bmatrix} Y_{G1_11} & Y_{G1_12} \\ Y_{G1_21} & Y_{G1_22} \end{bmatrix} \begin{bmatrix} F_{bit} \\ F_{a1} \end{bmatrix}$$

Port Function Representation

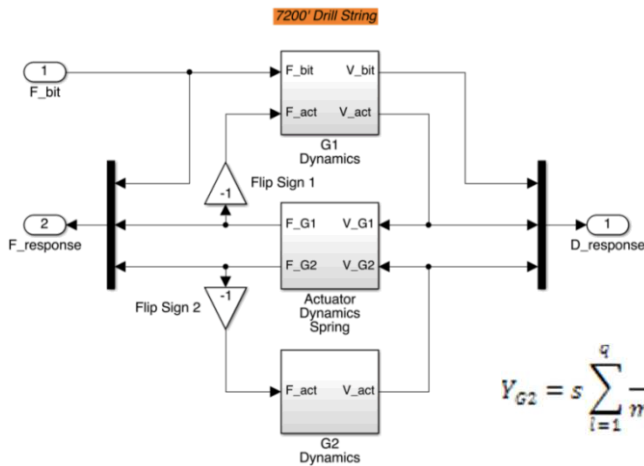

$$Y_{G2} = s \sum_{i=1}^q \frac{\phi_{ni} * \phi_{ni}}{m_i s^2 + c_i s + k_i}$$

From Normal Modes

Drillstring Structural Dynamics Predictions

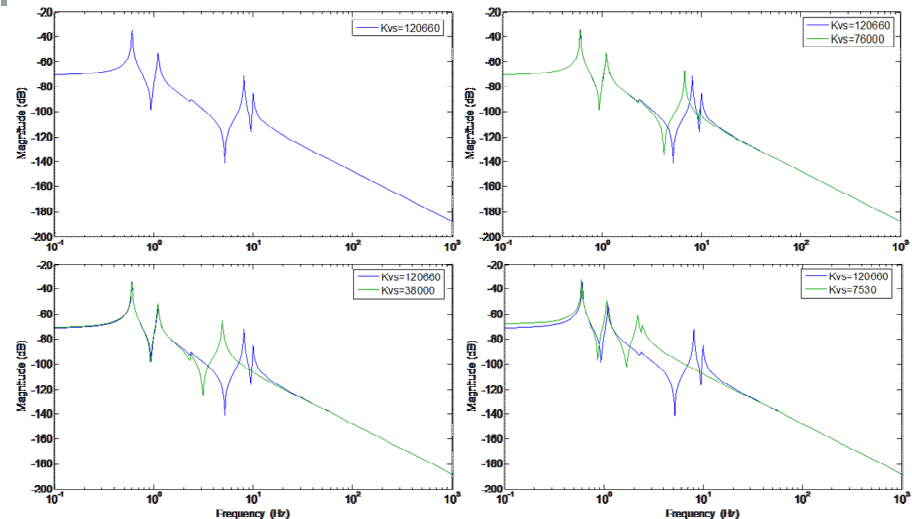

Rock/Bit Interaction

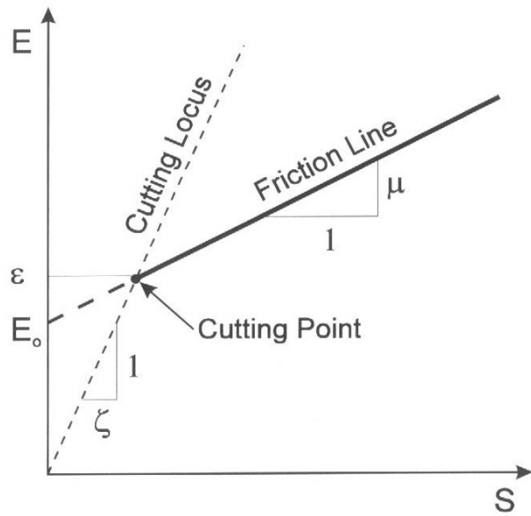

Numerical Drilling Simulations of Instability

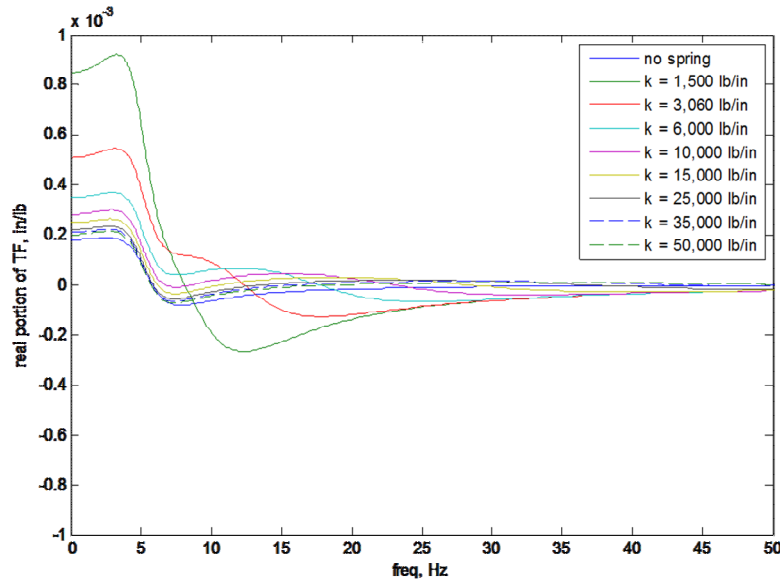
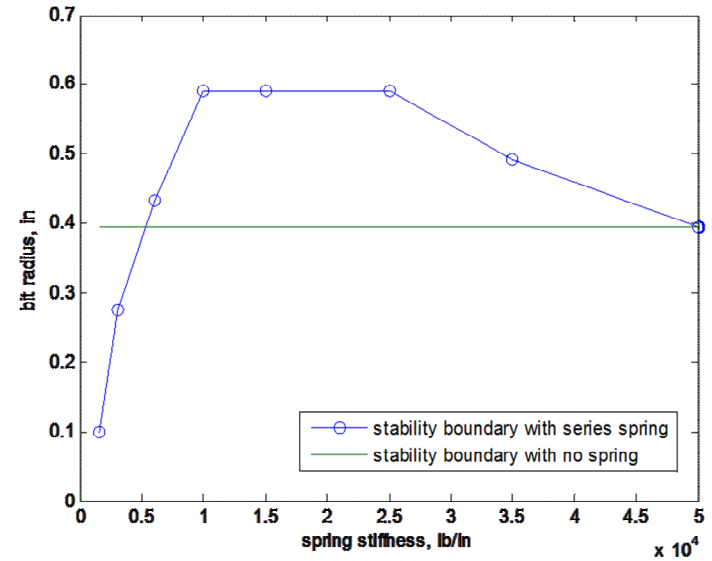

Time Domain Modeling with FEM

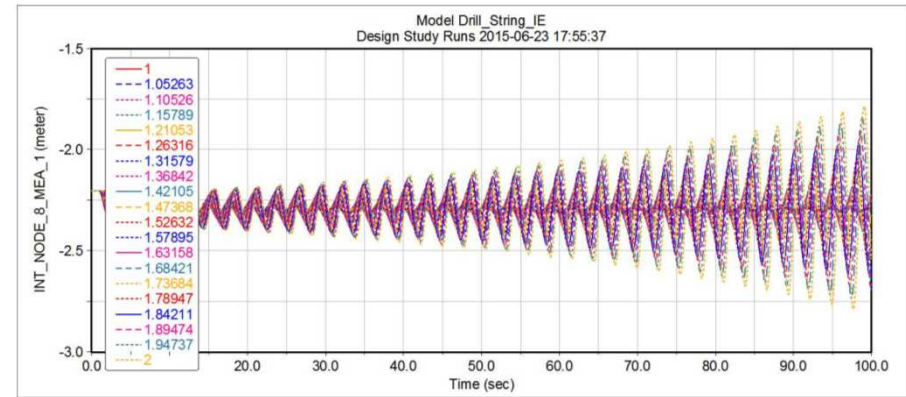

- Variable Rate Springs

- Solid State Belleville stack
 - Modular activation approach with drillstring form and function
 - Stacks can be selectively engineered for preferred response

- Shape Memory Alloys (SMA)

- Sandia internal and external industry contacts established
 - Viability for drilling application addressed

- Liquid Springs

- Contracted with Taylor Devices
 - Design study for application suitability completed

- Downselect for VRS Concept

- Belleville Spring Stack
 - Shape Memory Alloy (SMA) Actuators
 - Downhole Sensors, DAQ & Controller

Ref: Key Bellevilles

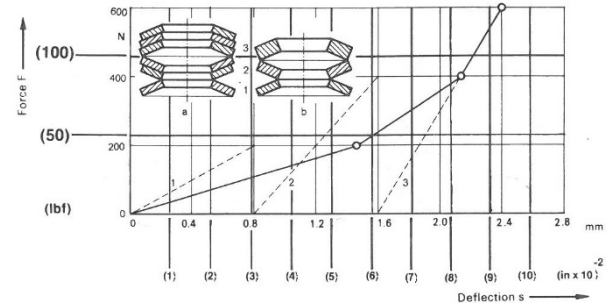

Ref: NDC (Stoeckel & Waram)

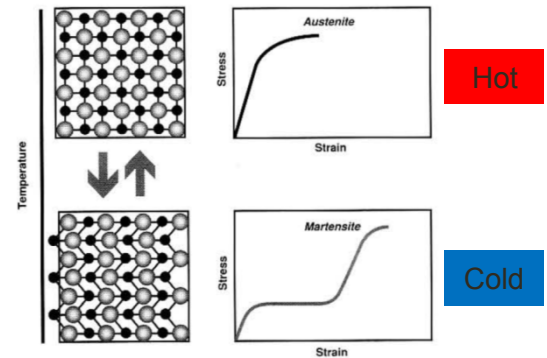
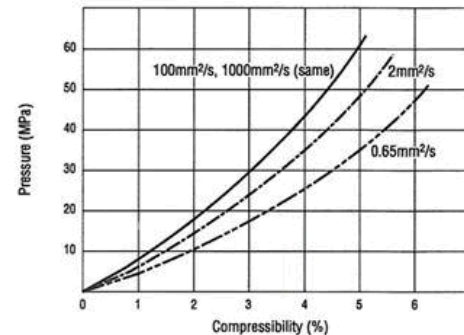
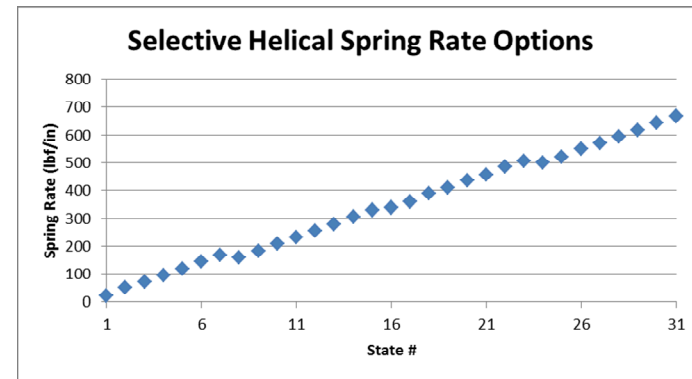
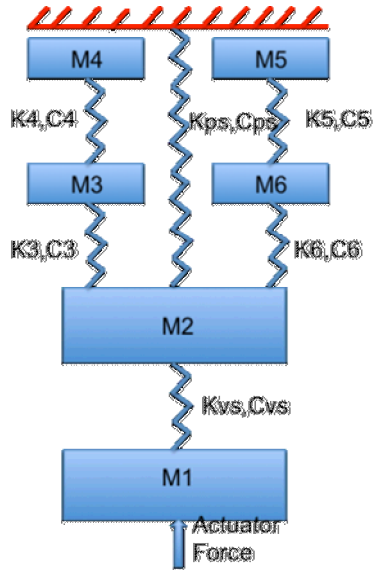

Fig. 1. Martensitic transformation and tensile behavior of Ni-Ti alloys.

Ref: Shin-Etsu Chemical Co.





Mode #	Tlusty	DDS
1	0.345	0.673
2	1.25	1.22
3	2.29	2.35
4	10.4	9.22
5	19.8	28.3

(Modal frequencies in Hz)





Drilling Instability Testing

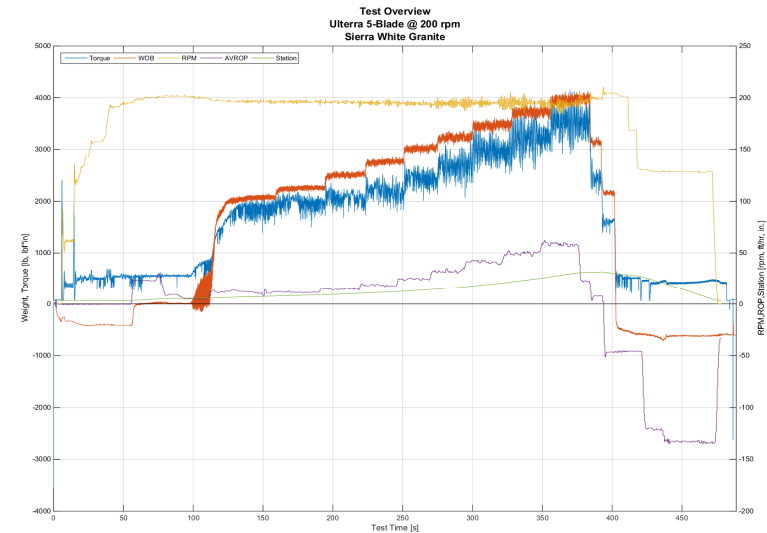
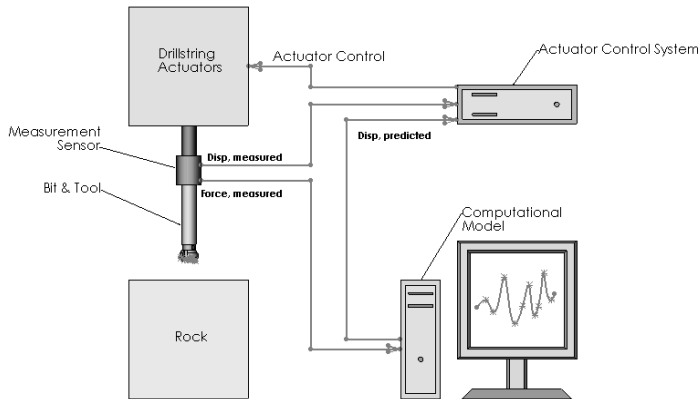

Variable Rate Spring Fixture Testing

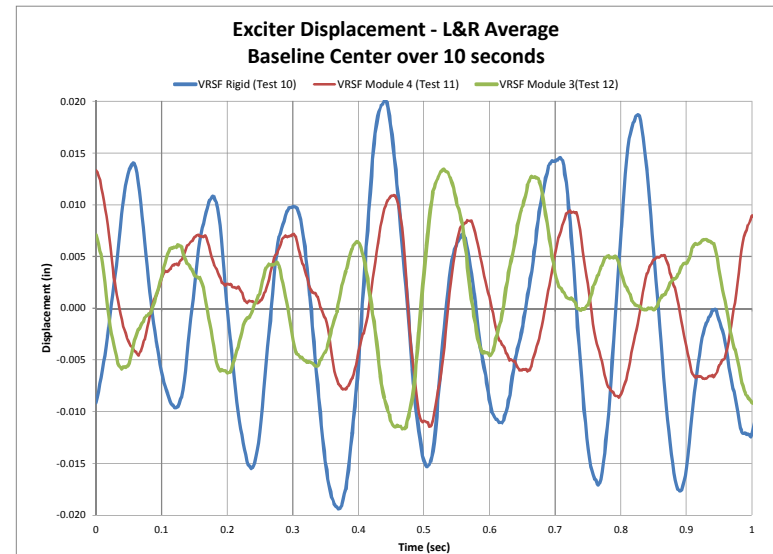
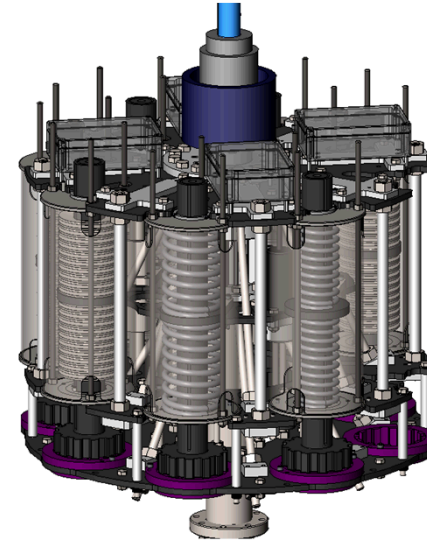

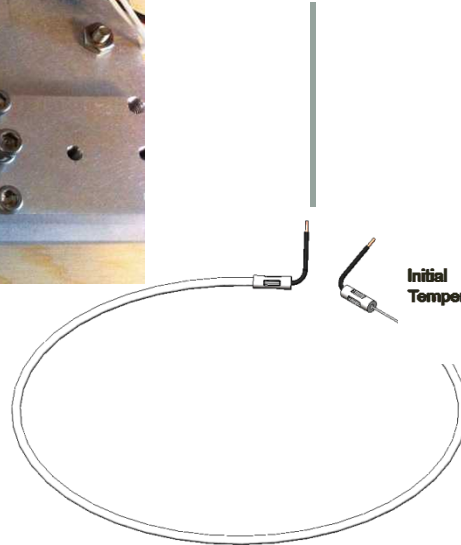
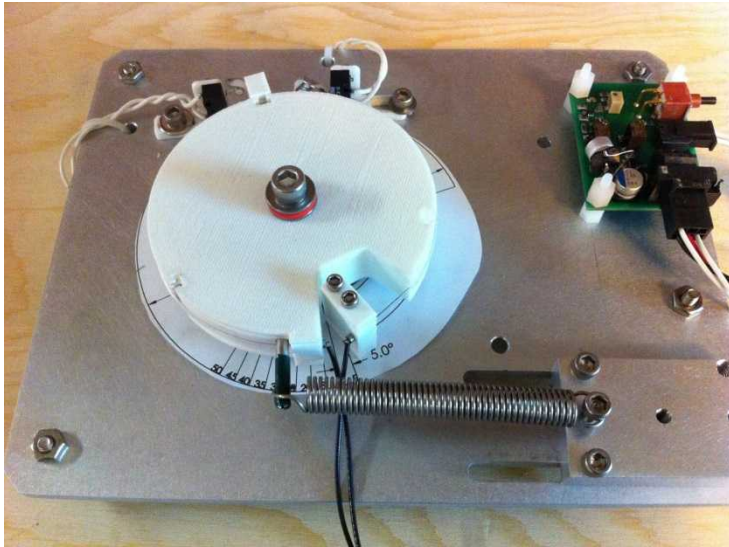

Plot Format

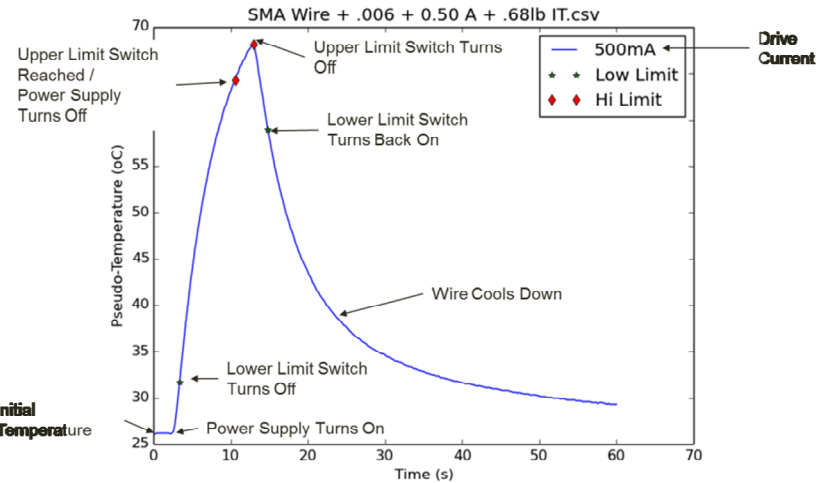

Data - .012" Wire

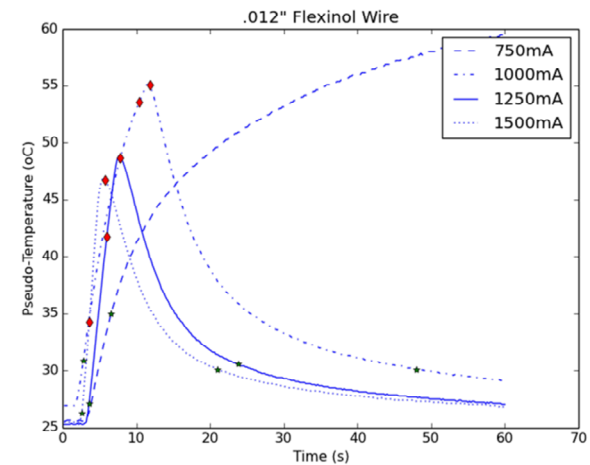

- Validates geometrical constraints of smart materials for rotary actuator.
- High Torque to Power ratio
 - ~15X More efficient than a rotary solenoid.

	SMA Actuator	Rotary Solenoid
Input Power	7 W	7 W
Output Torque	3 in-lb	0.2 in-lb

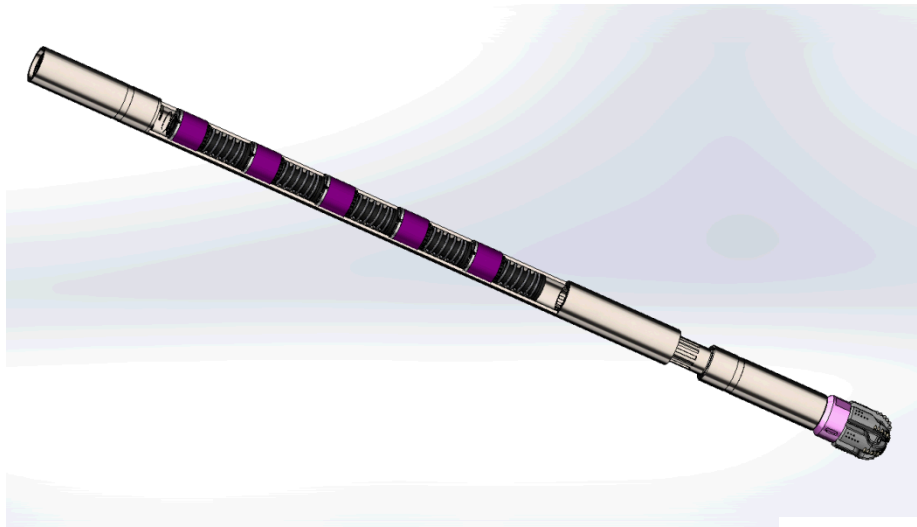

Smart Spring Module

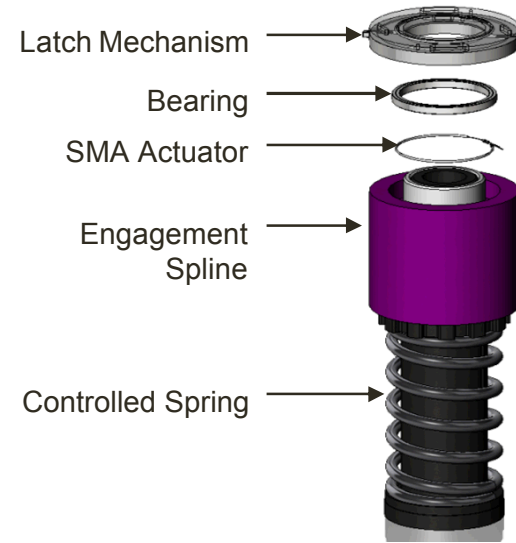

Patent Pending

Spline
"Engaged"



Spline
"Disengaged"



Project # 165620

PI: David Raymond (06916)

Purpose, Goals & Approach

- Evaluate suitability of variable rate spring technologies
- Conduct POC on feasibility/benefit of vibration management
- Use computational modeling, controls evaluation, & validation of control concepts

Significance of Results

- Unique analytical capability
- Innovative concept for variable rate drilling tool assembly
- IP developed
- Avoid damaging vibrations
- Reduce drilling costs, improve performance



Prototype
Controllable
Element

Key R&D Accomplishments

- Computational model developed
- Substructuring capability derived
- Control evaluation achieved
- Conceptual design for prototype tool with variable rate spring
- Conceived use of smart materials
- Lab drillstring validation devised
- Drilling applicability demonstration completed

What's Next

- Continue bit work with Ulterra Drilling Technologies
- Seek opportunities to collaborate with current DOE/GTP sponsorship
- Seek program development funds for service company engagement
- Identify commercial partner
- Develop prototype tool with controllers, sensors, processors & actuators
- Conduct field testing
- License

Publications, Presentations, and IP Technology

Publications resulting from this project, including those under review and in preparation

- SAND Report – Active Suppression of Drilling System Vibrations for Deep Drilling
- DYNAMIC SUBSTRUCTURING OF DRILLSTRING COMPUTATIONAL MODELS FOR EXPLORATION OF ACTUATOR ALTERNATIVES, David Raymond, Mikhail Mesh & Steve Buerger, Third International Colloquium on Nonlinear Dynamics and Control of Deep Drilling Systems, University of Minnesota, Minneapolis, May 29-30, 2014.

External presentations resulting from this project. Identify invited conference presentations

- Invited - DYNAMIC SUBSTRUCTURING OF DRILLSTRING COMPUTATIONAL MODELS FOR EXPLORATION OF ACTUATOR ALTERNATIVES, David Raymond, Mikhail Mesh & Steve Buerger, Third International Colloquium on Nonlinear Dynamics and Control of Deep Drilling Systems, University of Minnesota, Minneapolis, May 29-30, 2014.

Intellectual property resulting from this project

- Technical Advances Filed:
 - 12869 Solid State Spring Using Shape Memory Alloys (SMA)
 - 12870 Variable Rate Mechanical Spring for Suppression of Drilling Vibrations
 - 12871 Variable Rate Liquid Spring for Suppression of Drilling Vibrations
 - 12849 Active Cancellation of Drill String Vibrations Using Inertial Exciters
- Patent Application Filed and Pending:
 - VARIABLE RATE COMPLIANCE MODULE, ASSEMBLY AND TOOL FOR SUPPRESSION OF DRILLING VIBRATIONS, Docket No. SD-12870/32467-0021

Active Suppression of Drilling System Vibrations

Project # 165620

PM: Doug Blankenship (06916)

PMU Benefit & Timeframe

- Supports initiatives for borehole disposition of NW / Applicable to broad energy drilling sector
- Enhances SNL reputation with industry and DOE
- IP being secured, papers & licensing in FY15/16

Impact and S&E Legacy

- Drilling vibrations a major performance limiter – work addresses this issue
- SNL capabilities in computing, controls, engineering and testing make this effort possible – work enhances future partnerships

Efforts to Leverage R&D

- DOE aware of general effort – bolsters our national leadership position in drilling research
- Industry (e.g., XOM, Ormat) being informed of SNL vibration mitigation efforts
- Work presented at International Colloquium on Deep Drilling Systems, Minneapolis, May 2014

What's Next

- Identify sponsorship for continuation
- Continue with laboratory POC testing
- Secure IP
- Publish
- Engage operators and drilling service companies
- License

Thank You