

Hydrogen, Water, Electrons: Providing the Means for a Sustainable World

Ivan Ermanoski

Sandia National Laboratories

Sandia is a multi-program laboratory operated by Sandia Corporation, a Lockheed Martin Company, for the United States Department of Energy's National Nuclear Security Administration under contract DE-AC04-94AL85000.

Outline

- **On the needs and means of humanity**
- **Fuels and how to get them**
- **Challenges in solar-thermochemical fuel production**
- **Water and power**
- **Beyond the means of today**

Outline

- **On the needs and means of humanity**
- **Fuels and how to get them**
- **Challenges in solar-thermochemical fuel production**
- **Water and power**
- **Beyond the means of today**

Hydrogen, Water, Electrons: Means to an End

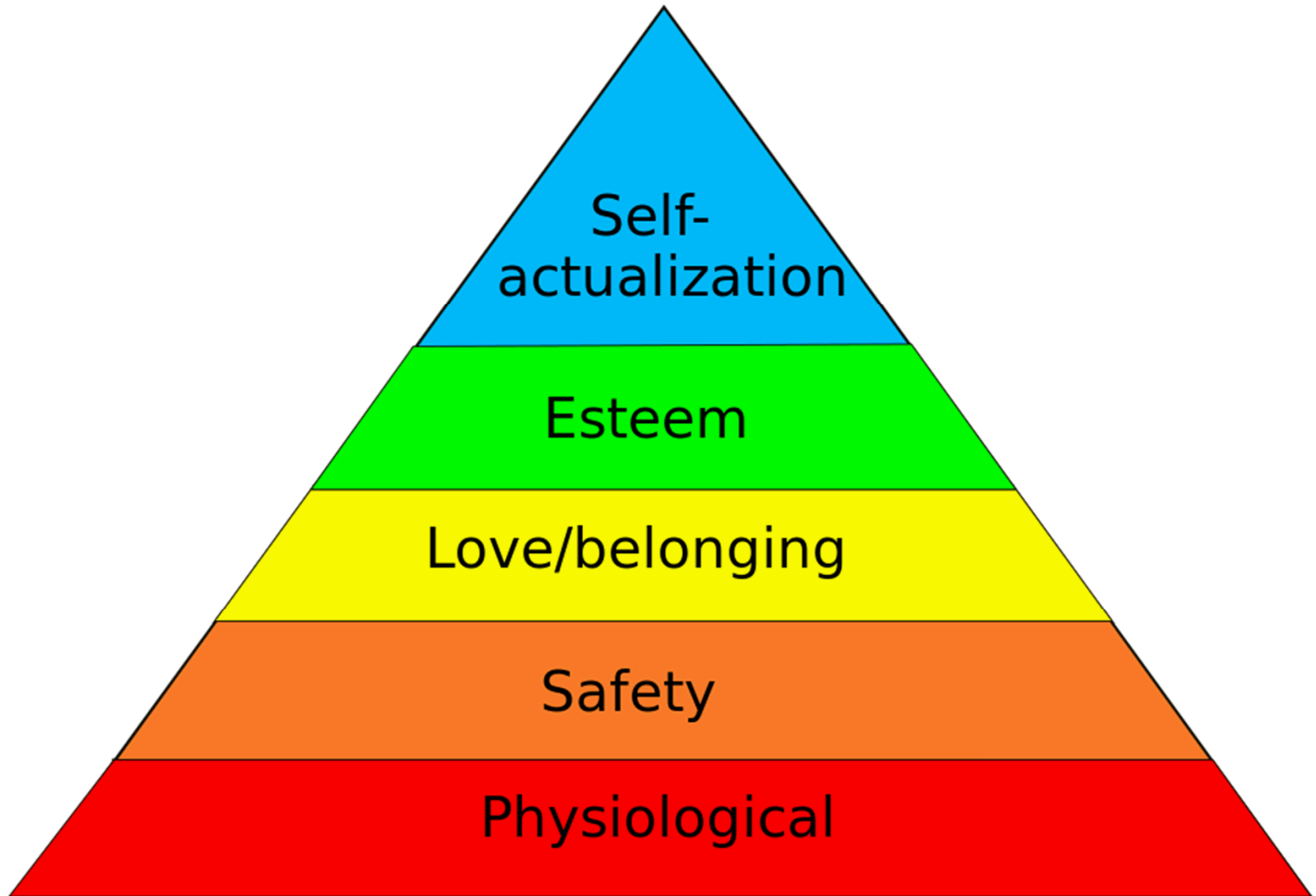

Means of Past, Present, and Future

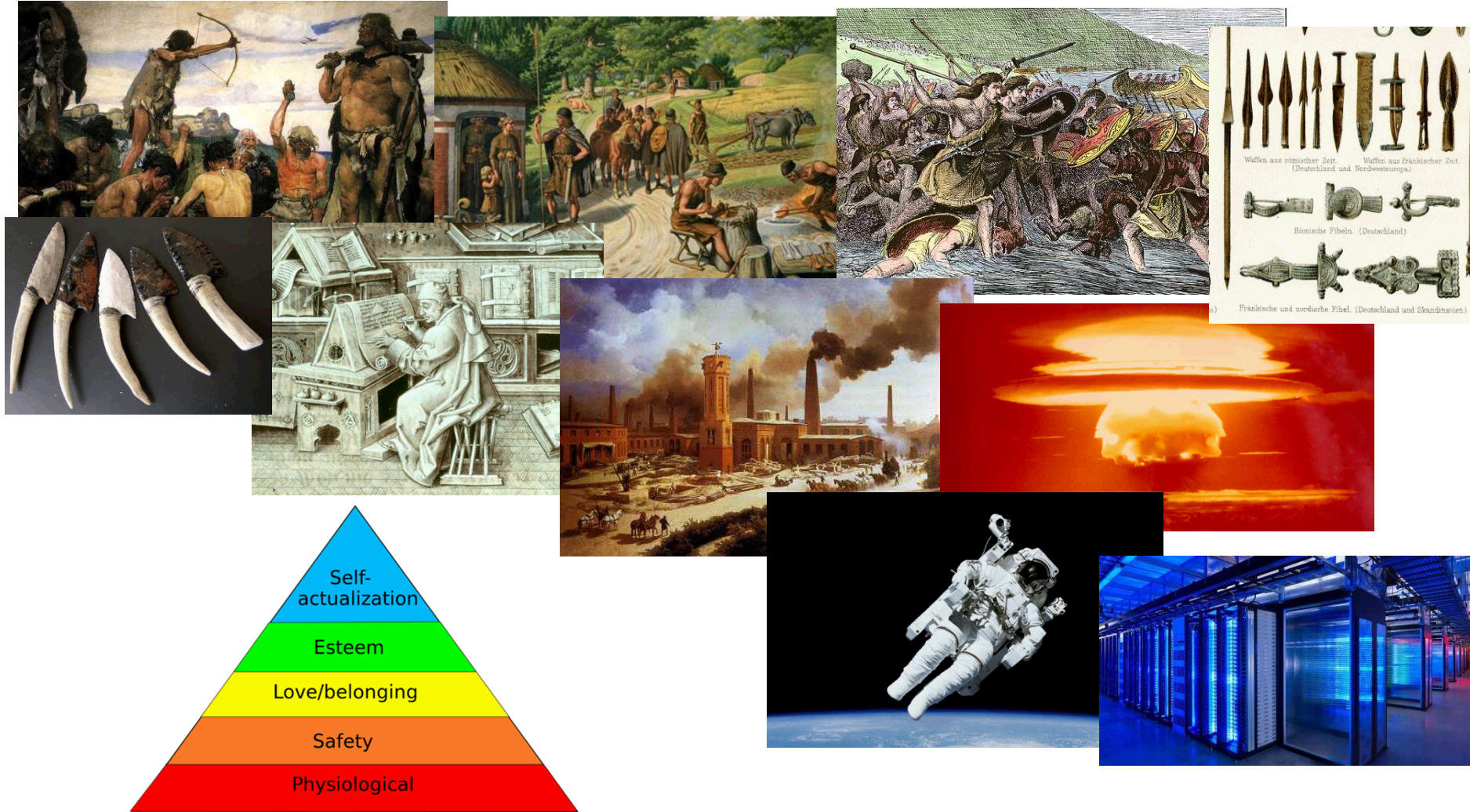

Needs are rather stable, but means undergo vast changes.

Outline

- **On the needs and means of humanity**
- **Fuels and how to get them**
- **Challenges in solar-thermochemical fuel production**
- **Water and power**
- **Beyond the means of today**

The 19th & 20th Century Fuel Paradigm...

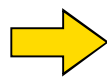
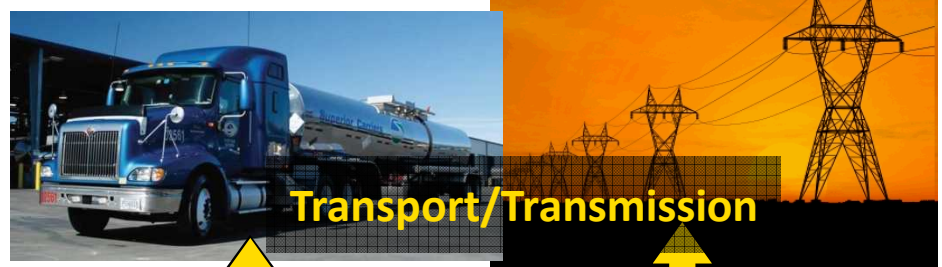
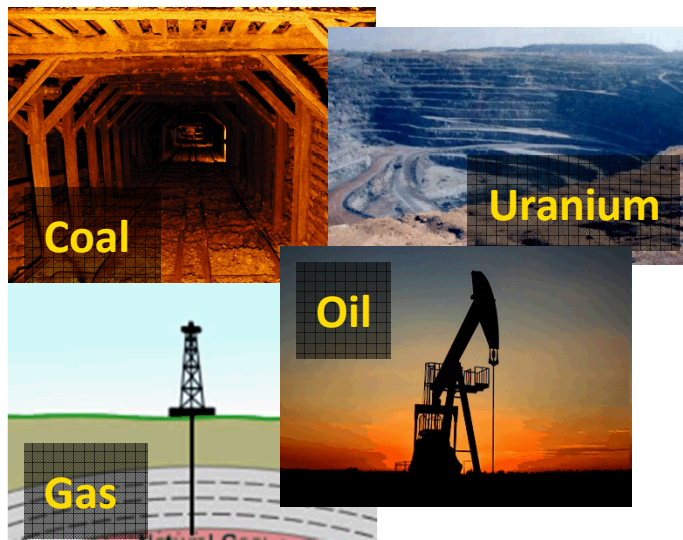

...and the Potential Consequences

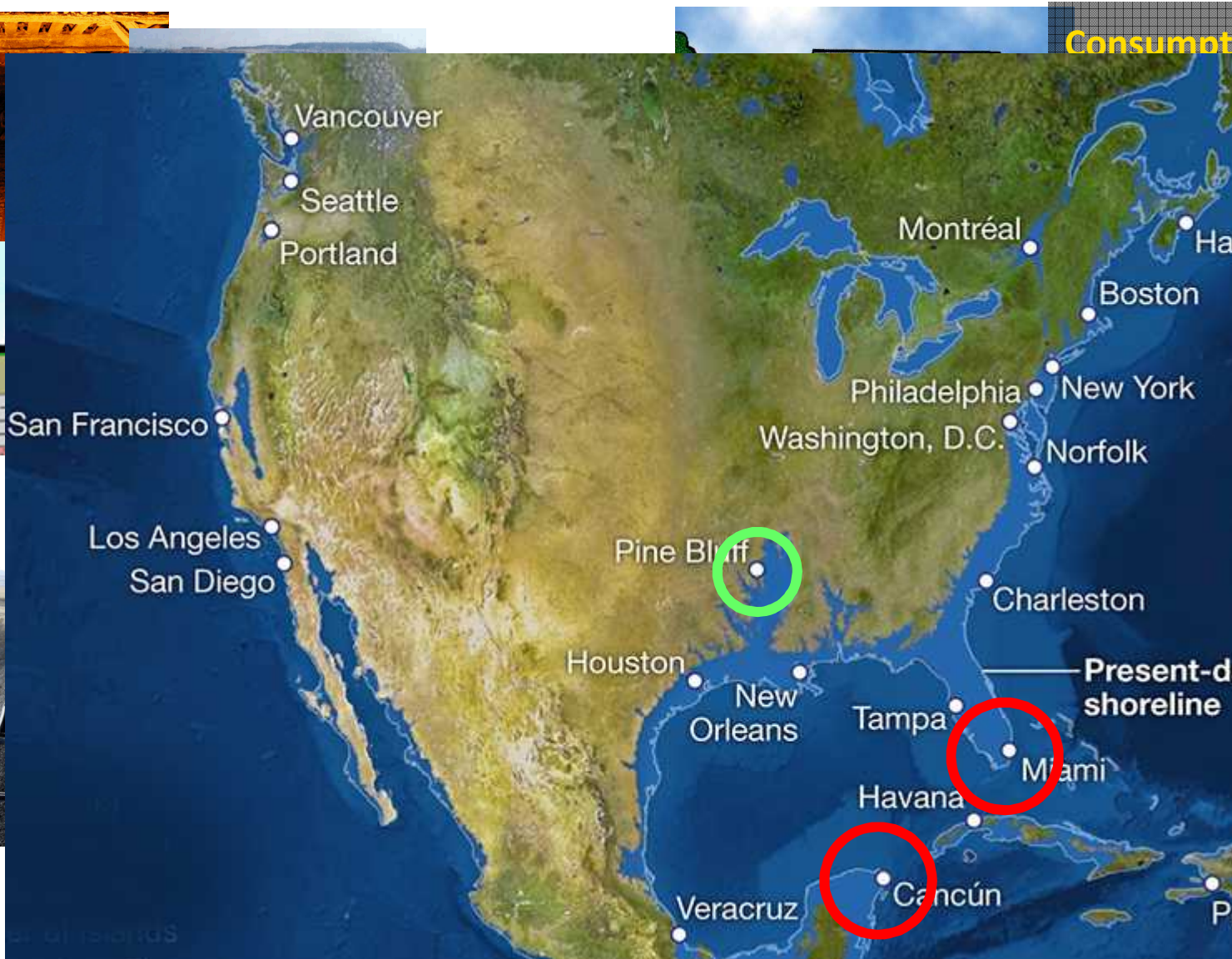

Consumption

Coal

Gas

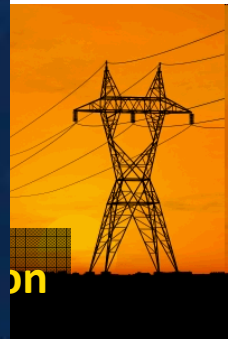

Power plant

Renewing

Fuels From Sunshine: Thermochemistry

A deceptively simple process

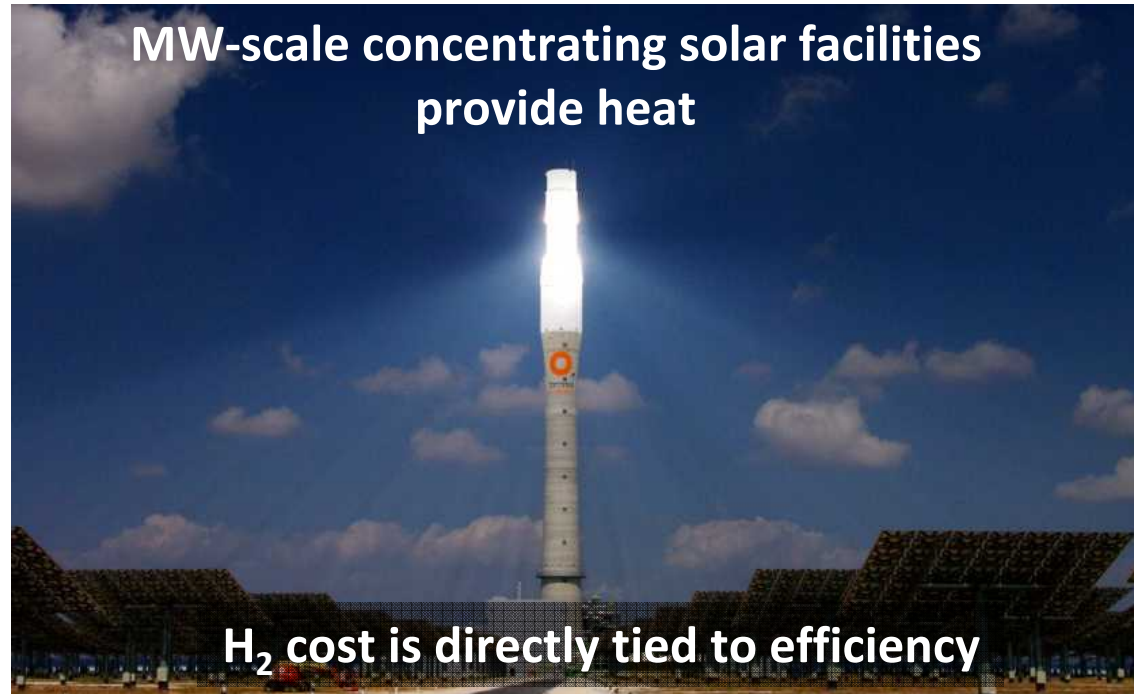
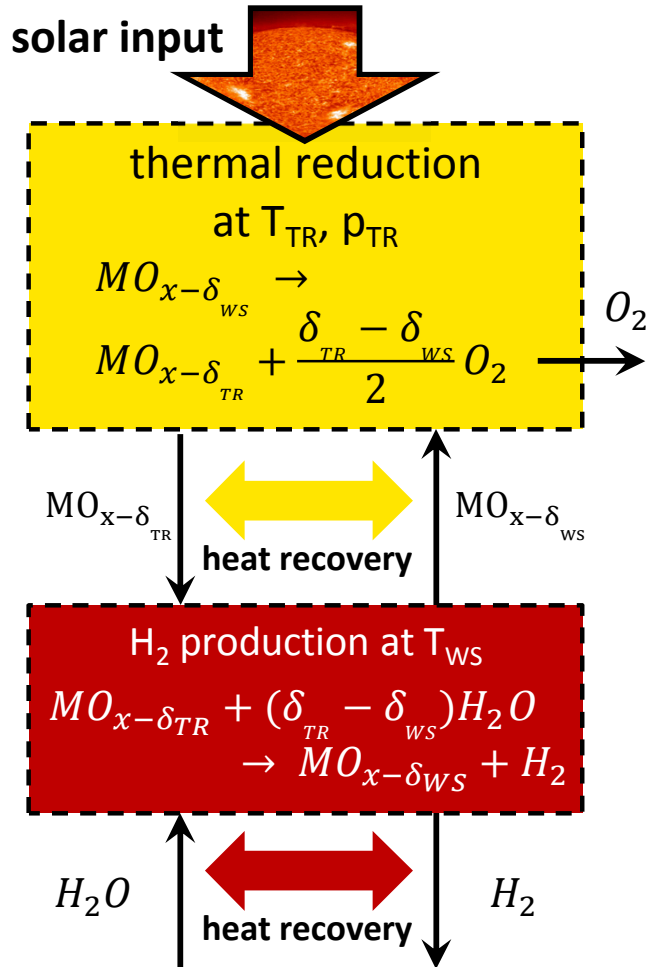

Challenge: Develop **efficient and scalable** solar-thermochemical reactors.

Fuels From Sunshine: Thermochemistry

A deceptively simple process

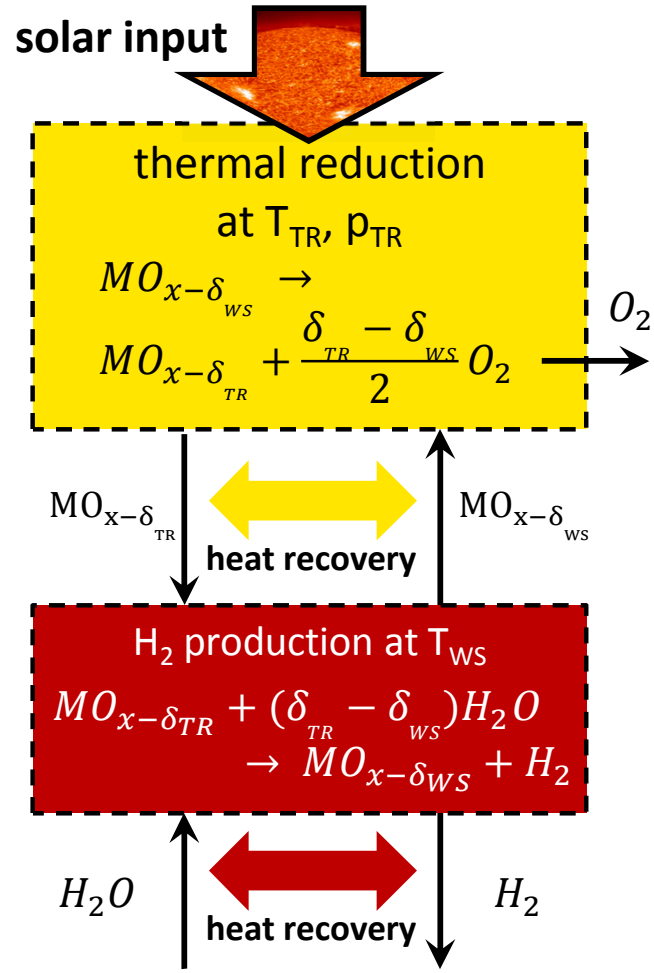

Overall challenges:

- High temperature ($\sim 1500^\circ C$)
- Low reduction pressure (~ 10 Pa)
- Material redox chemistry

Key reactor design and operation principles:

- Direct solar absorption
- Continuous on-sun operation
- Internal heat recovery and reuse
- Temperature and product separation
- High-vacuum thermal reduction
- Optimal reaction temperatures

Technological requirements:

- Scalability - MW
- Reactor and material durability
- Wide operational flexibility

Challenge: Develop **efficient and scalable** solar-thermochemical reactors.

SNL Solar Reactors: Over a Decade of Innovation

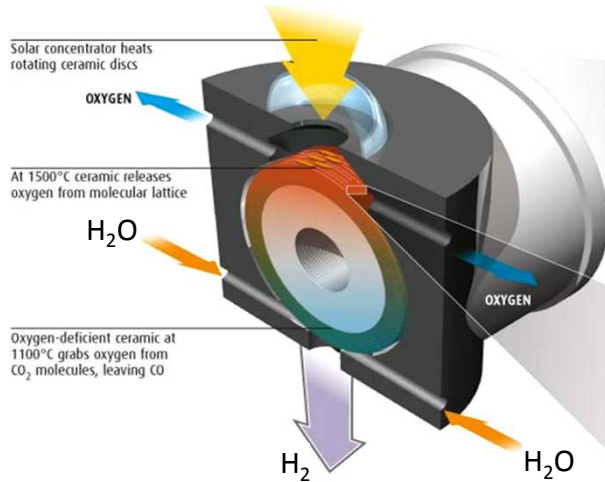

Counter-Rotating-Ring Receiver Reactor Recuperator (CR5): 2004-2012
 R. B. Diver et al., *J. Solar Energy Engineering* (2008) 130

- Direct solar absorption
- Internal heat recovery between T_{TR} and T_{WS}
- Continuous on-sun operation
- Temperature and product separation

Limitations:

- Reactive structures durability
- Reactor operation and material kinetics strongly coupled
- Thermal reduction $p_{TR} \sim 1-10\text{kPa}$

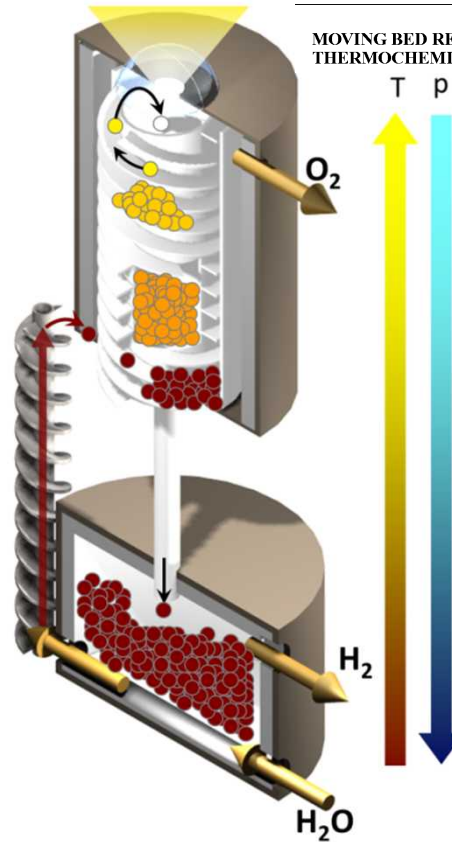

United States Patent
 Ermanoski

(10) Patent No.: US 8,420,032 B1
 (45) Date of Patent: Apr. 16, 2013

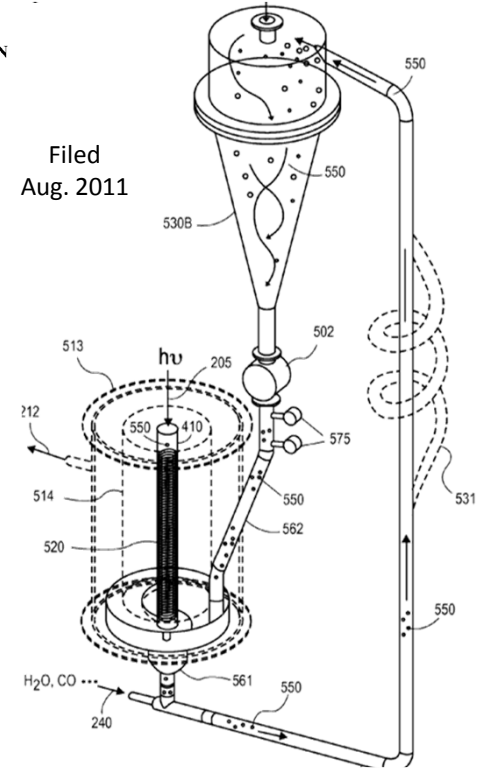

Moving Particle Bed Reactor: 2009-2014
 I. Ermanoski et. al, *J. Solar Energy Engineering* (2013) 135

Key improvements:

- Pressure separation (thermal reduction step vacuum pumping)
- Non-monolithic oxide
- Reaction kinetics decoupled from reactor operation

Limitations:

- $p_{TR} \sim 10-100\text{Pa}$
- Solid-solid heat recovery requirements

Outline

- On the needs and means of humanity
- Fuels and how to get them
- Challenges in solar-thermochemical fuel production
- Water and power
- Beyond the means of today

Key Material Requirements: Reactive Oxide

How much CeO_2 per mole H_2 ?

$$\delta_{TR} - \delta_{WS} = \Delta\delta \quad T_{TR} = 1773\text{K}$$

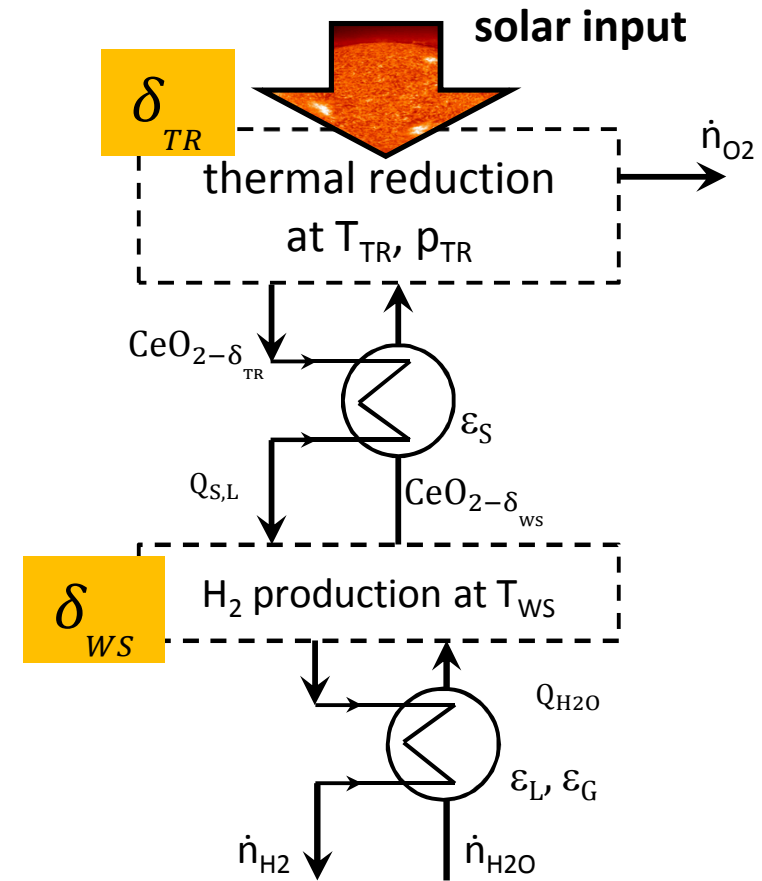
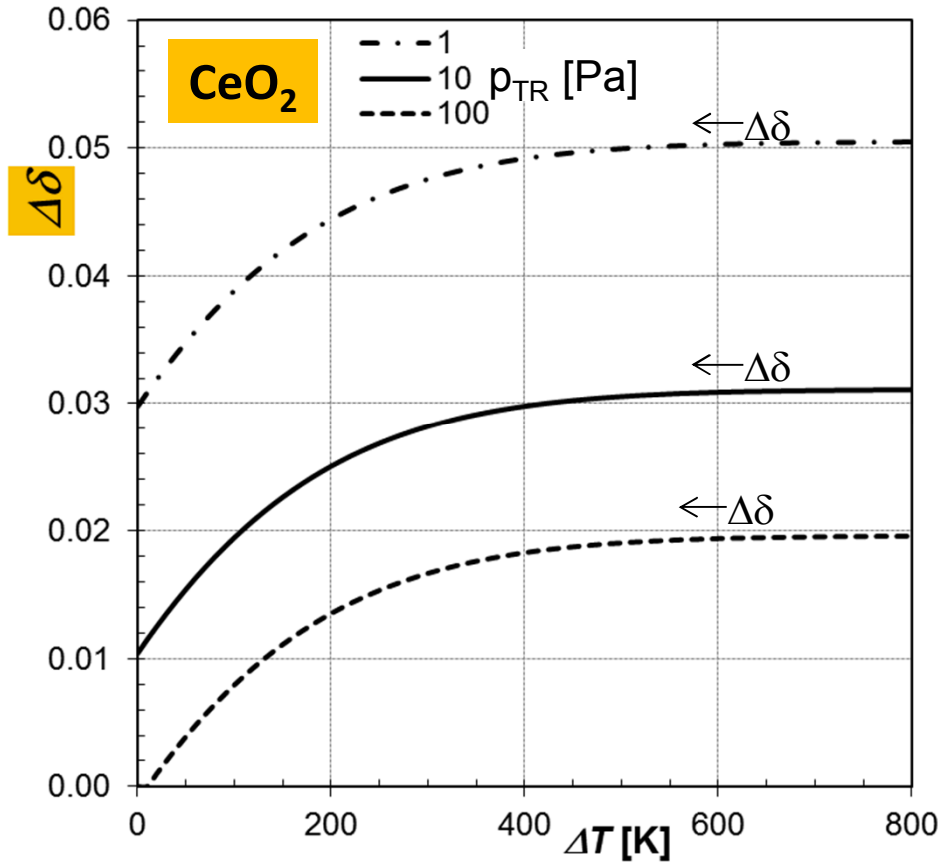

The reversible oxygen capacity can be very low.

Key Material Requirements: Reactive Oxide

How much CeO_2 per mole H_2 ?

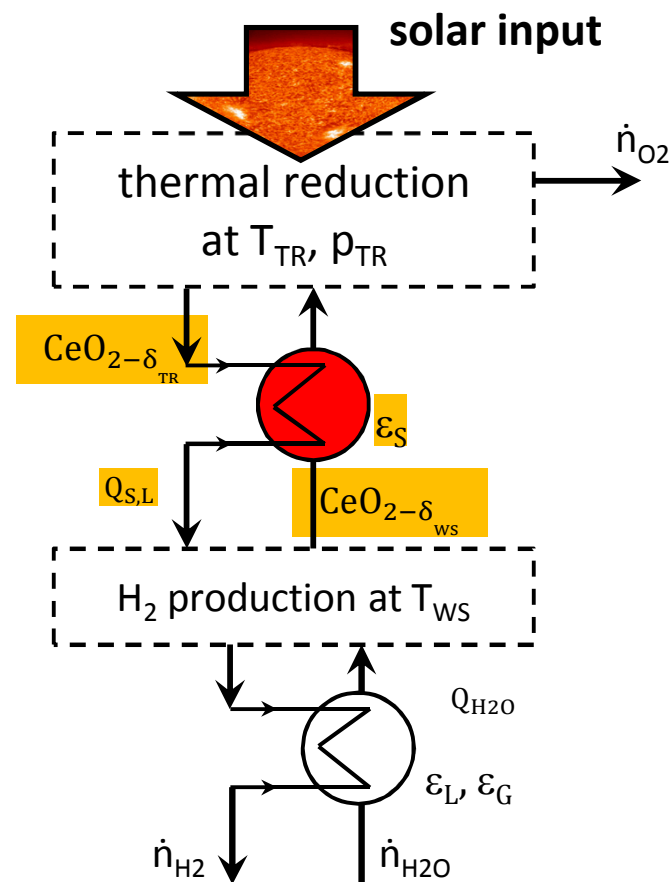
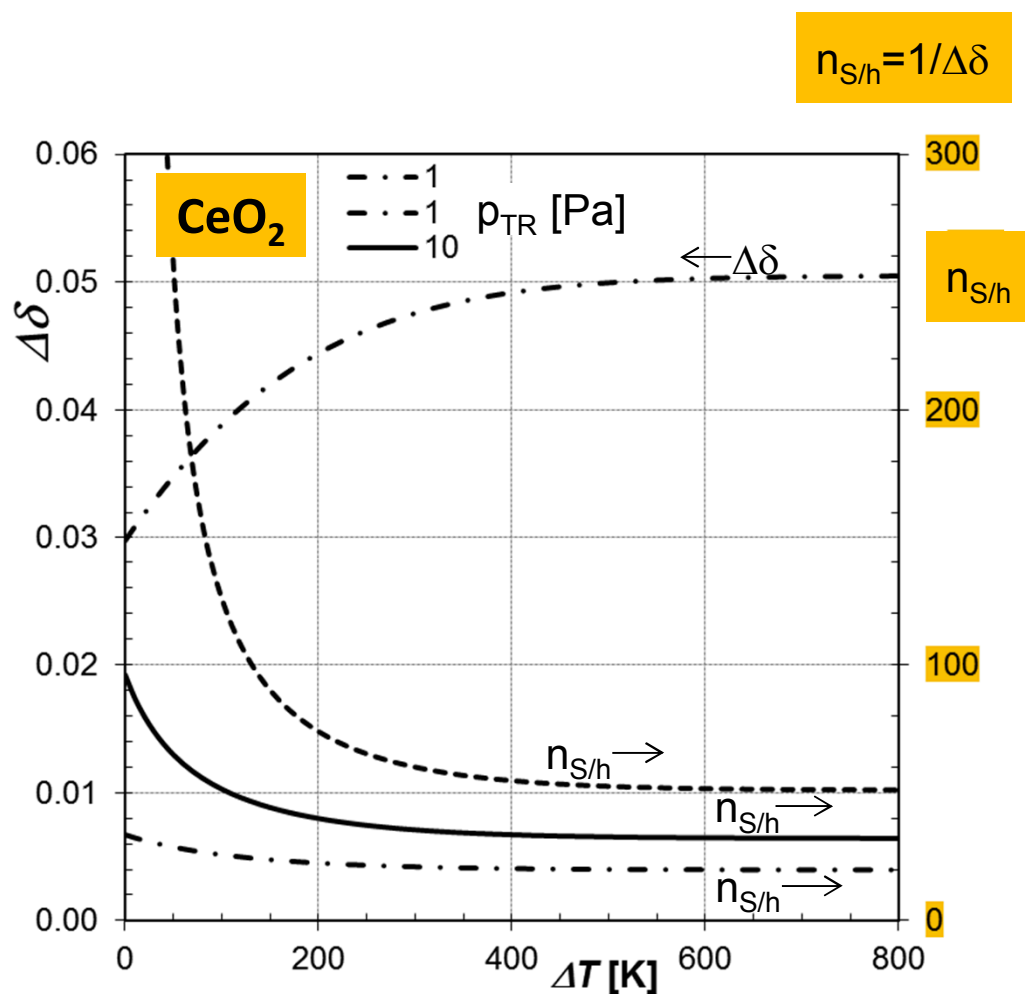

A low reversible oxygen capacity leads to a very high oxide/ H_2 ratio and excessive oxide mass flow and heat recovery requirements

Key Material Requirements: Reactive Oxide

How much CeO_2 per mole H_2 ?

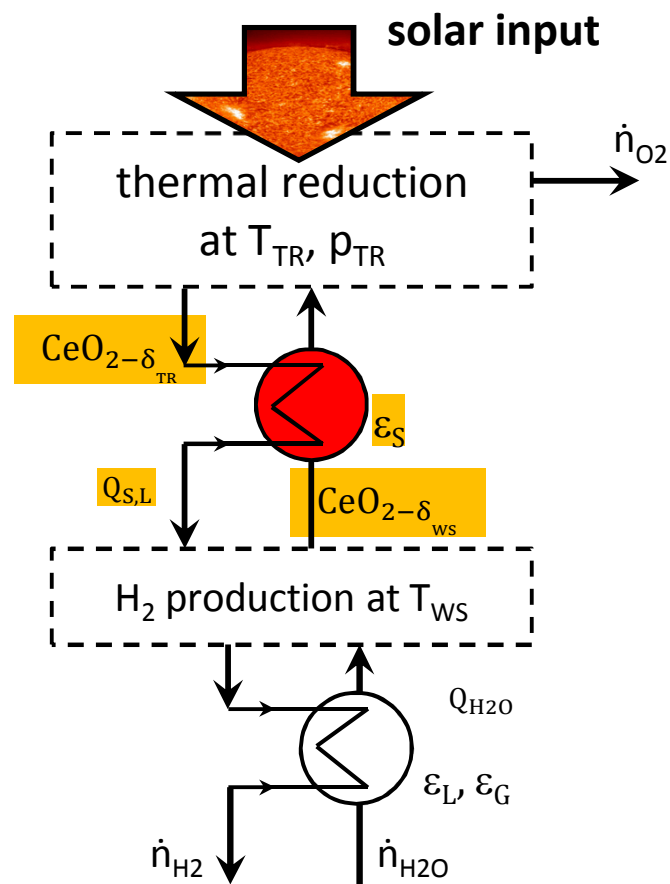
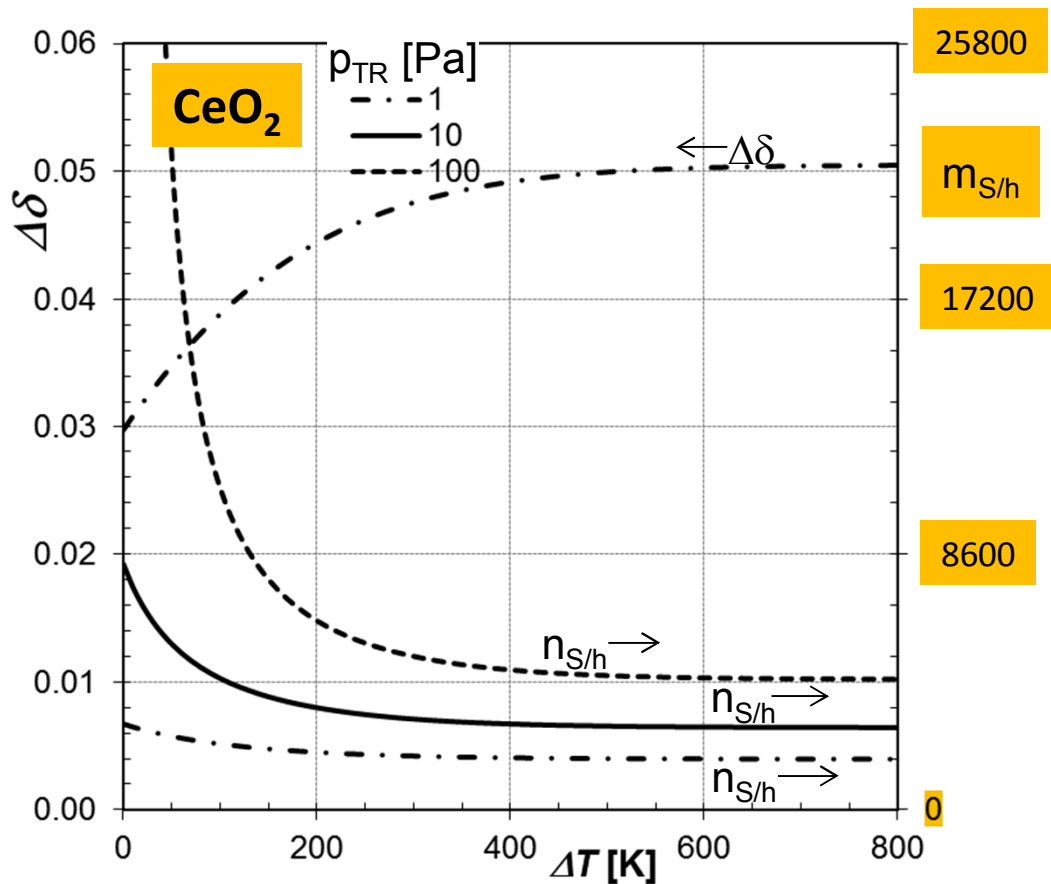

A low reversible oxygen capacity leads to a very high oxide/ H_2 ratio and excessive oxide mass flow and heat recovery requirements

Key Material Requirements: Steam

How much steam per mole H₂?

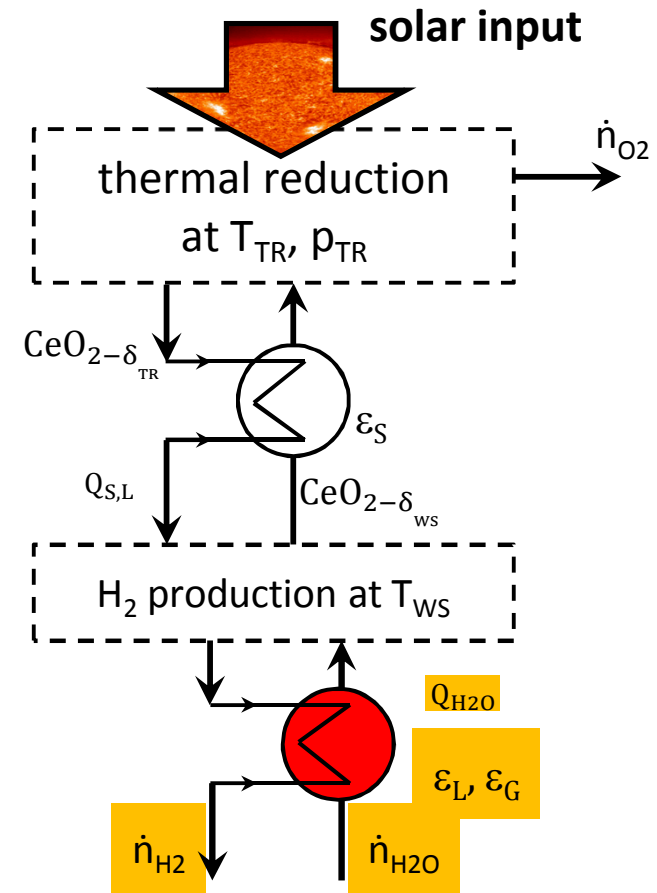
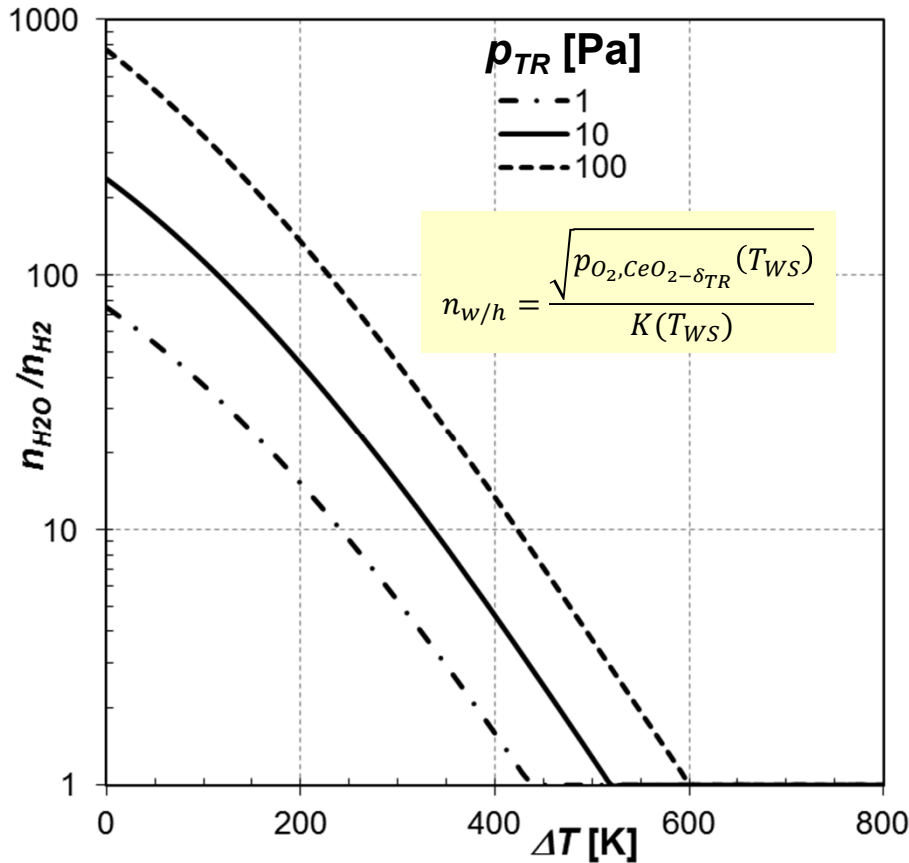

Low ΔT or high reduction pressure leads to a high steam/H₂ ratio

Maximizing Efficiency: Solid/Steam Heating Balance and a Low Reduction Pressure

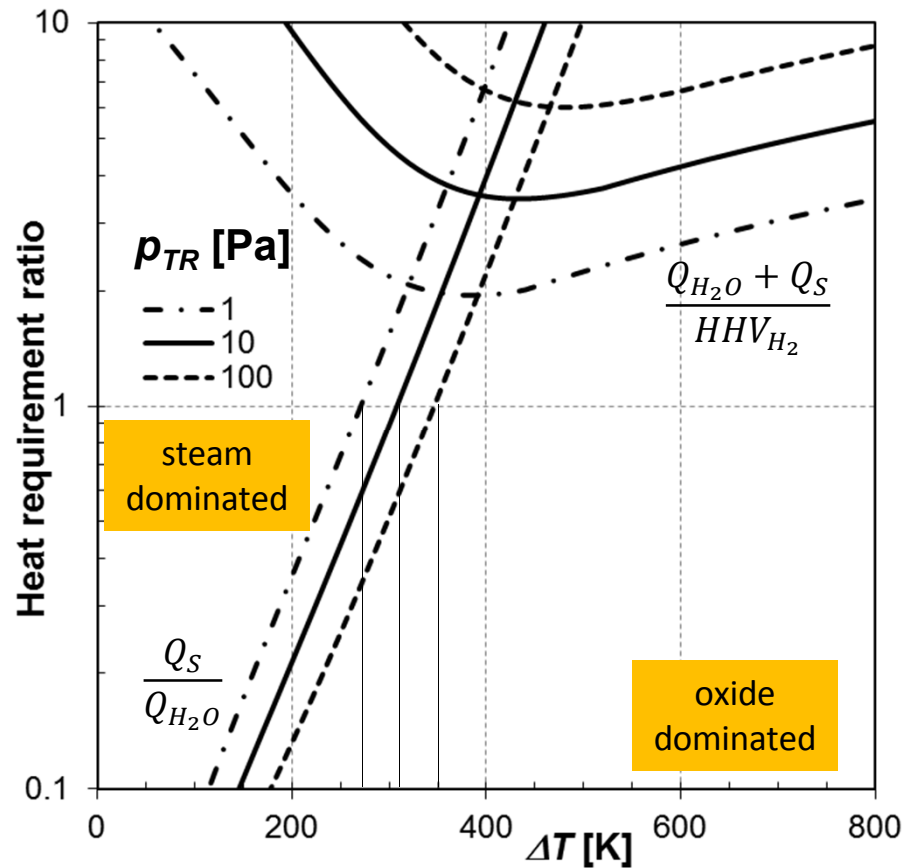

Efficiency is the highest when:

- Oxide and steam heating loads are roughly equal
- Thermal reduction pressure is low

Maximizing Efficiency: Solid/Steam Heating Balance and a Low Reduction Pressure

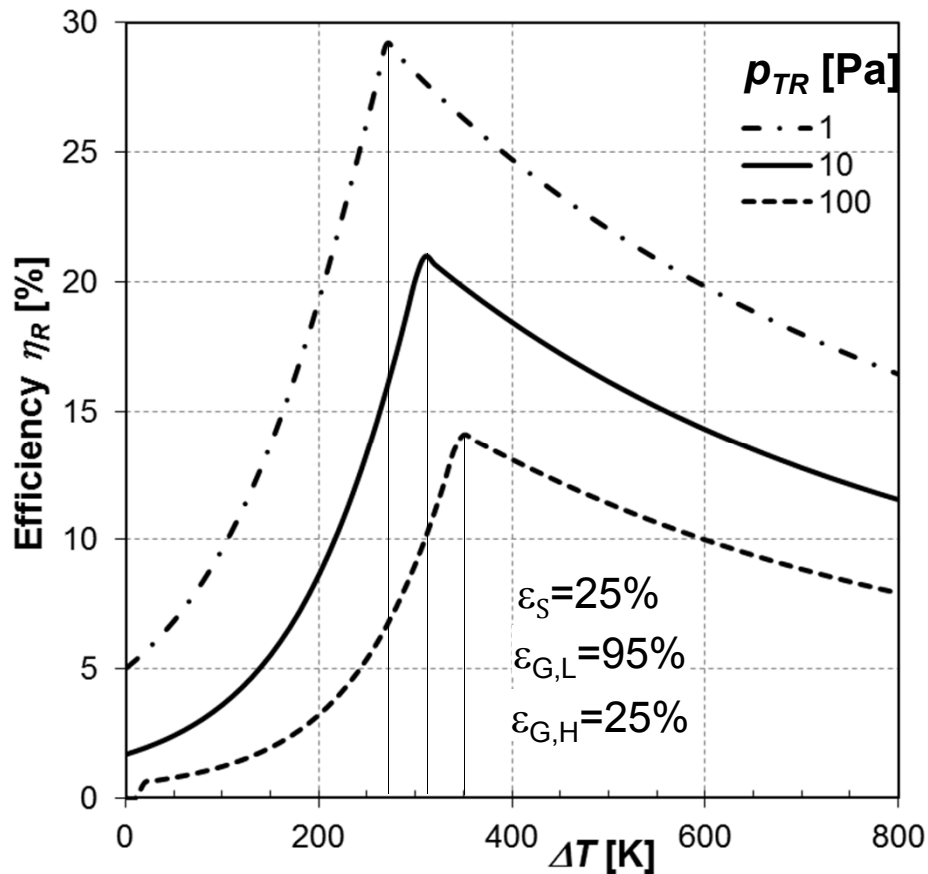

Efficiency is the highest when:

- Oxide and steam heating loads are roughly equal
- Thermal reduction pressure is low

O₂ Pressure Limits: Flow Volume and Speed

Is 1Pa accessible?

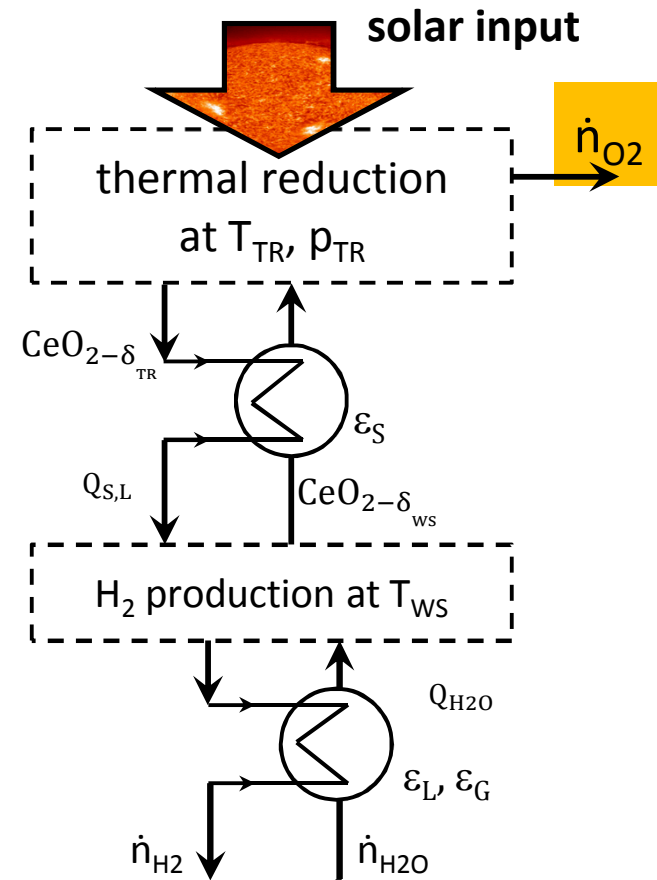
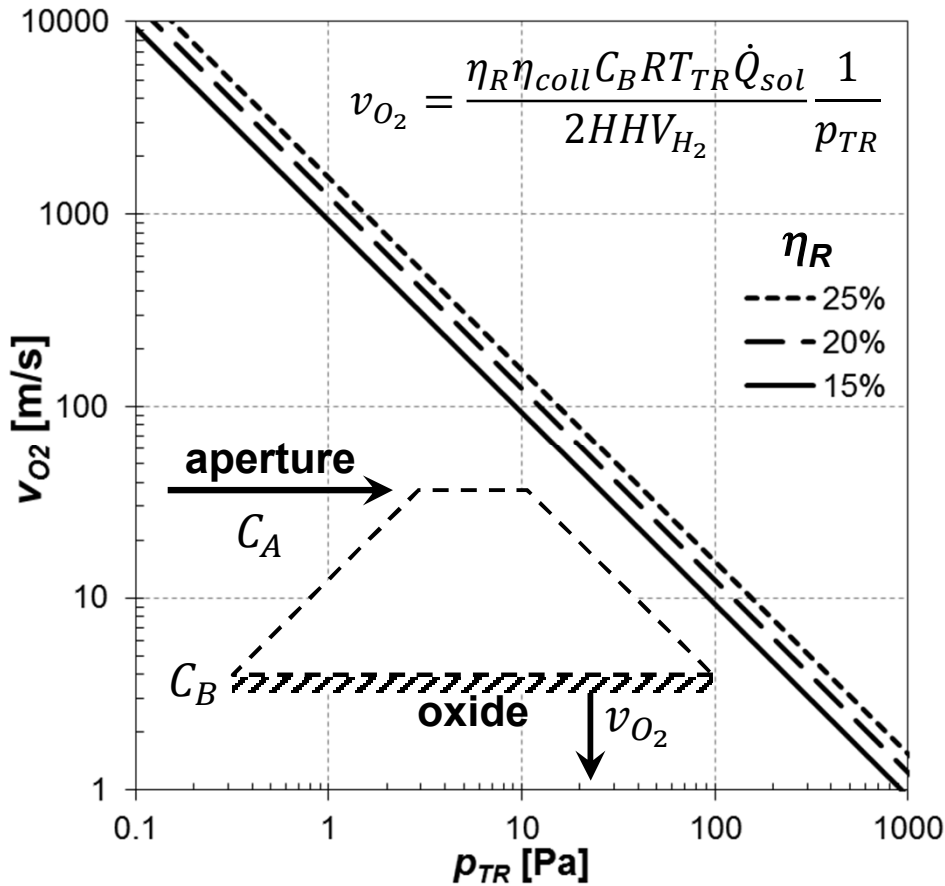

At low pressure required flow volumes and velocities are astronomical!

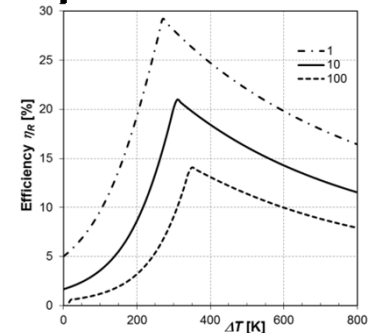

Cascading Pressure Reactor: A Moving Particle Bed Design for Ultra-Low Reduction Pressure

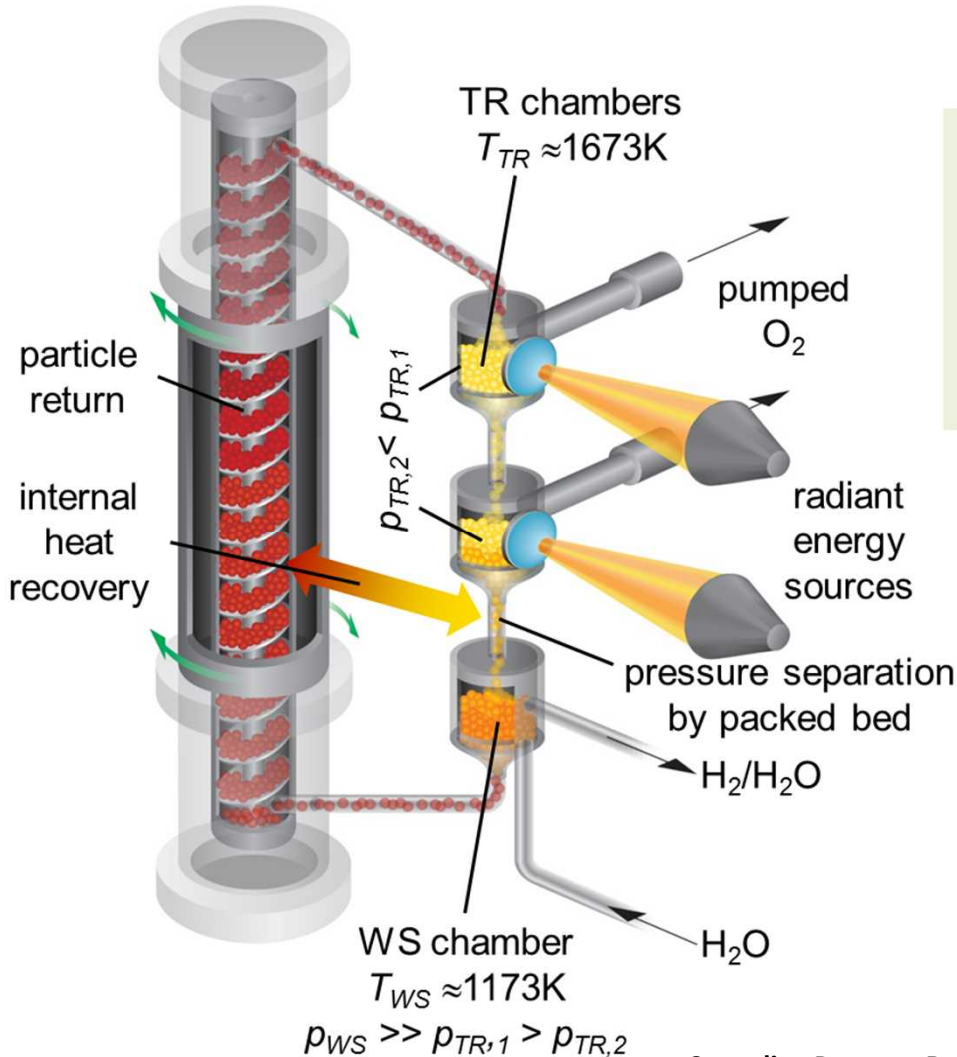

Key improvements:

- Thermal reduction pressure (0.1-10Pa)
- Decreased solid-solid heat recovery requirement
- Decreased pump work requirement
- Compatibility with MW-scale plant



Cascading Pressure Reactor: 2013-onward
I. Ermanoski, *Int. J. of Hydrogen Energy* (2014) 39

Staged Reduction for Low Pressure

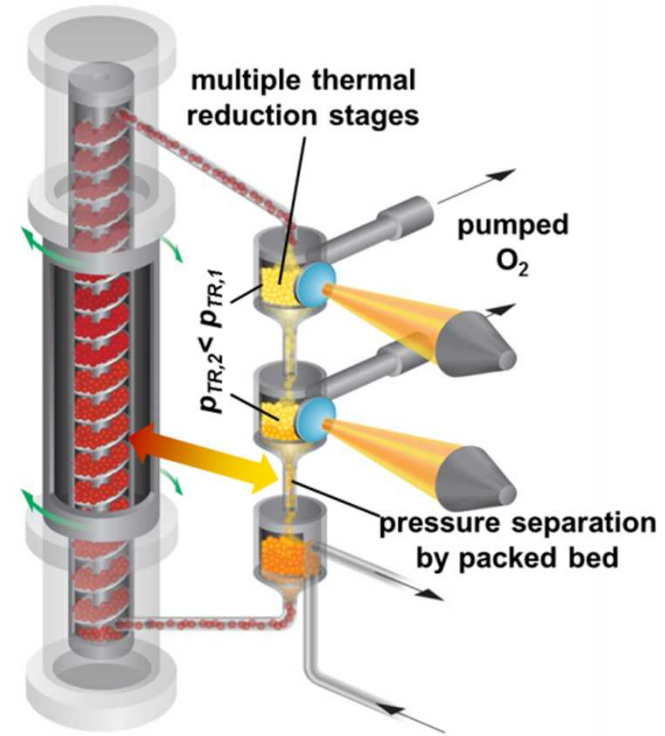
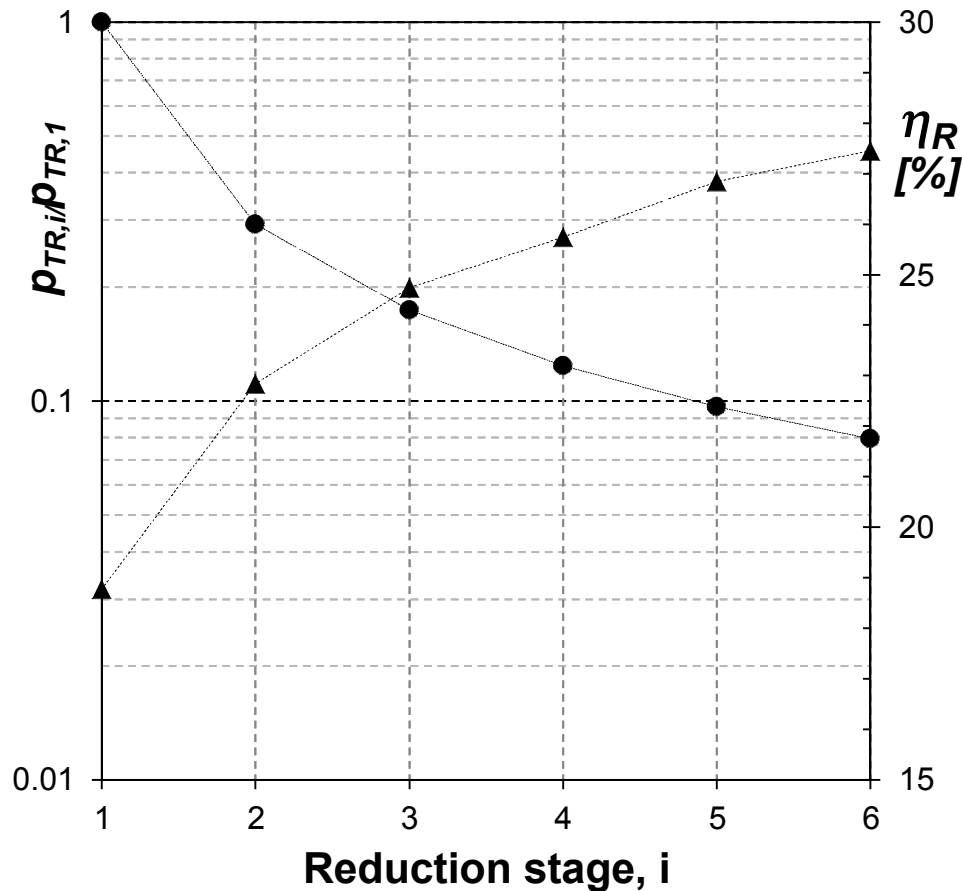

$$p_{TR,i} = \dot{n}_{ox} R T_{TR} \frac{\delta_{TR,i} - \delta_{TR,i-1}}{2 \dot{V}_{O_2}}$$

Incremental O_2 pumping reduces work, flow volume and velocity.

From Concept to Machine

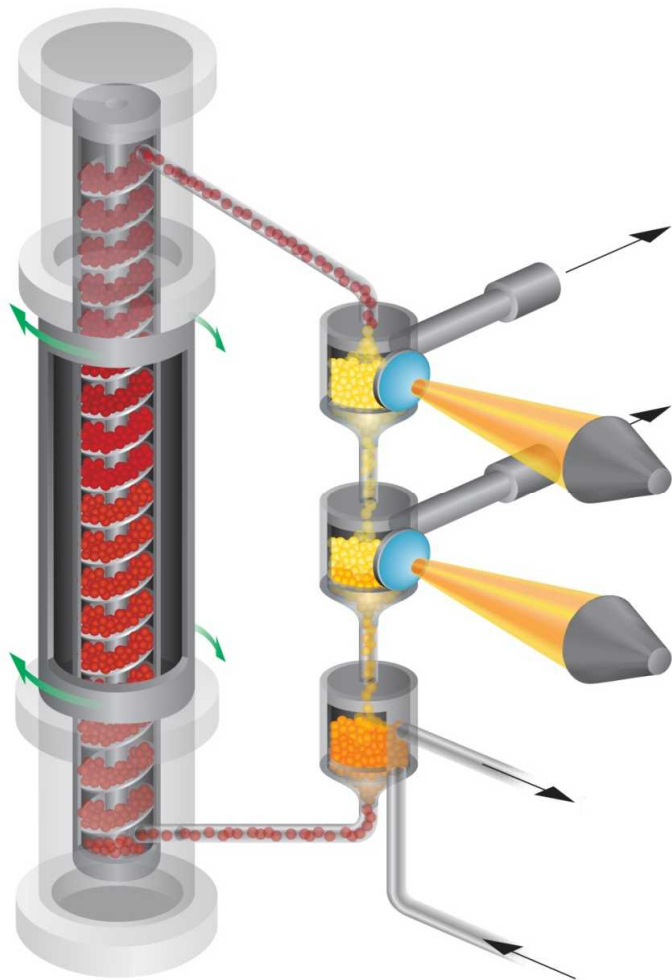

First light expected in a couple of weeks!

Outline

- **On the needs and means of humanity**
- **Fuels and how to get them**
- **Challenges in solar-thermochemical fuel production**
- **Water and power**
- **Beyond the means of today**

Water: Precious and Regulated in Best CSP Areas

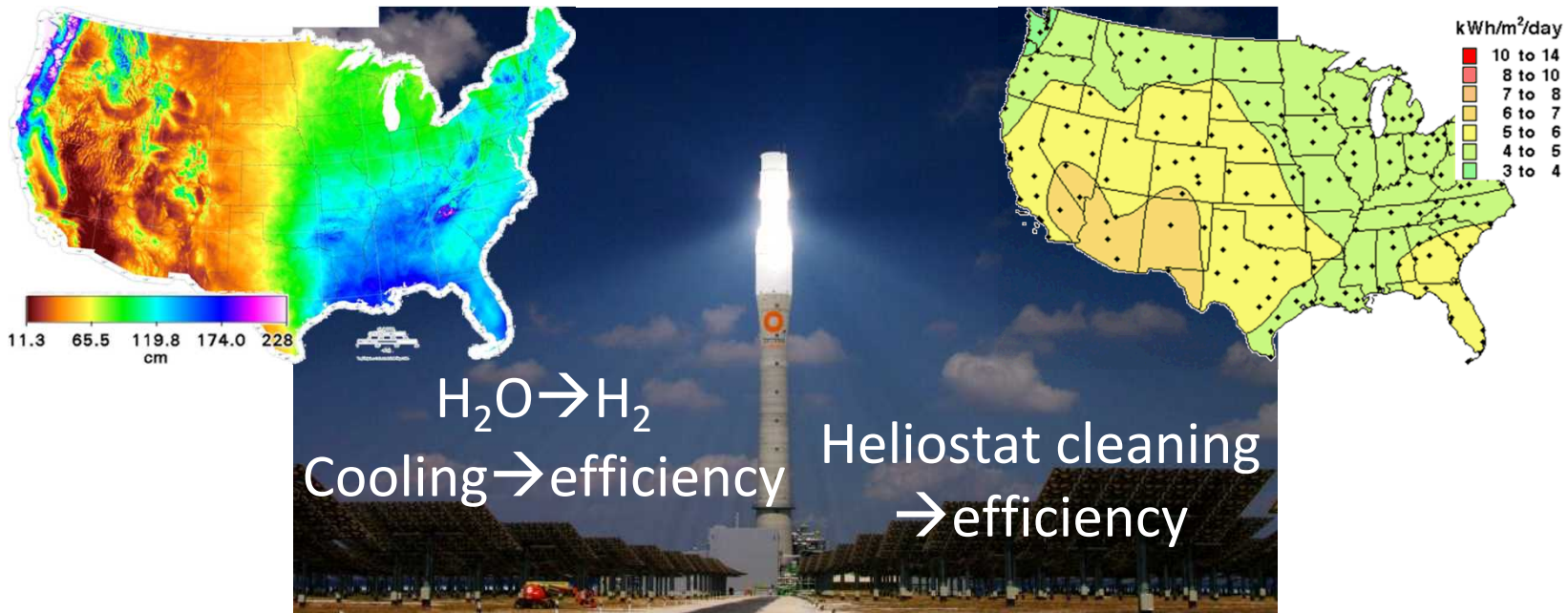

Water: Precious and Regulated in Best CSP Areas

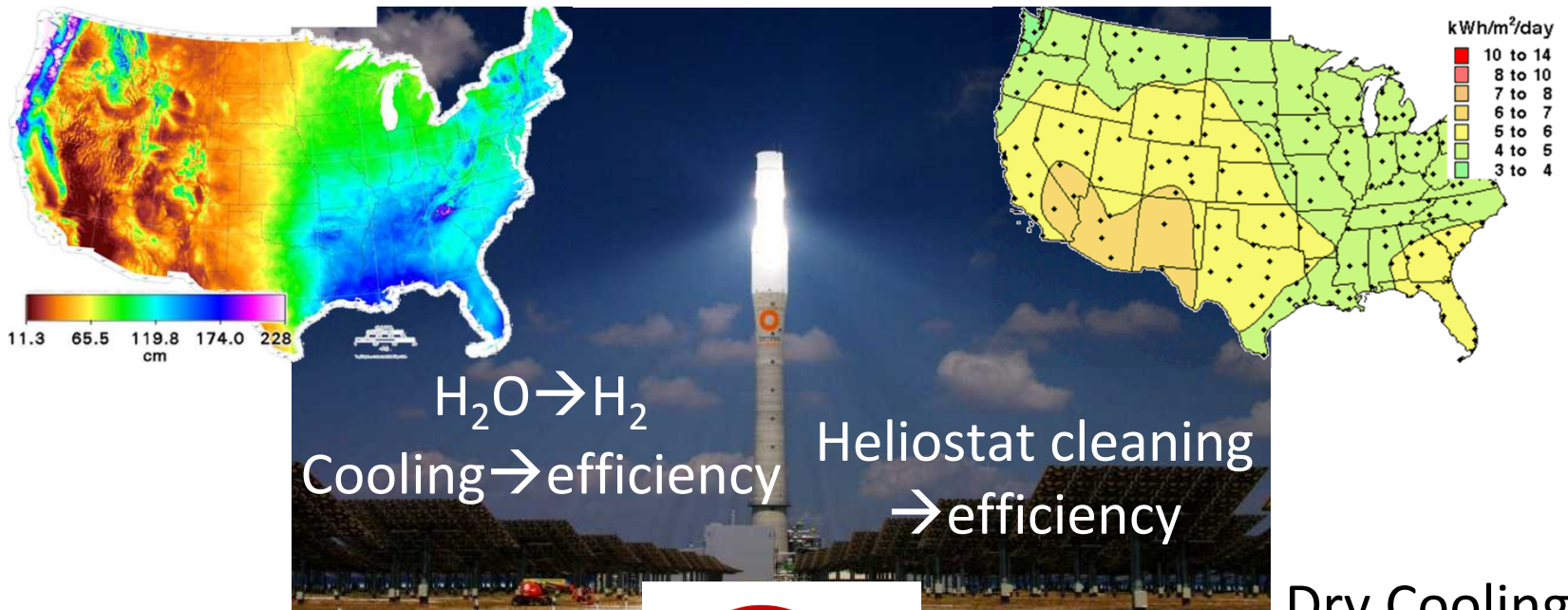

Ground Water/Wet Cooling

- Most efficient
- Most economical
- High water requirement
- Regulatory obstacles



Dry Cooling

- Inefficient
- Costly
- No H₂O – no H₂
- Low water requirement
- Less regulatory obstacles

Ground Water/Hybrid Cooling

- More efficient than dry cooling
- Less costly than dry cooling
- Flexible water requirement
- Regulatory obstacles

Air-Water Capture: Sorbents and Low Grade Heat

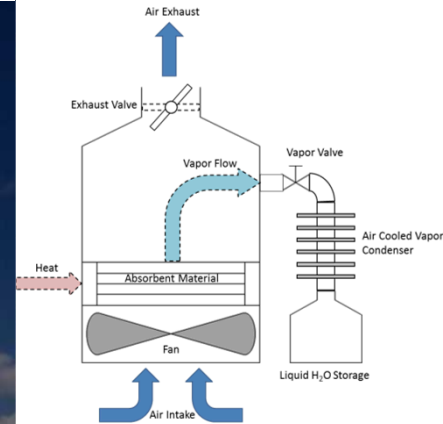
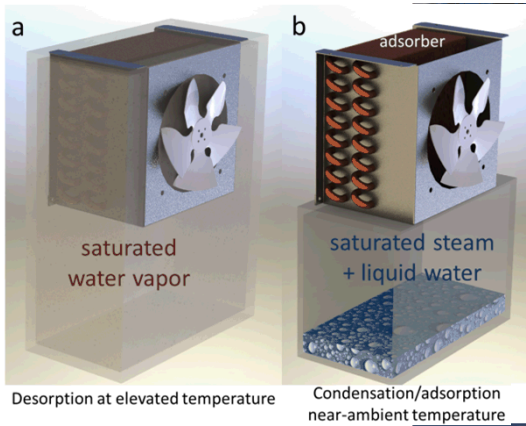

Power

- Higher efficiency than dry cooling
- Less costly than dry cooling
- Zero water requirement
- No regulatory obstacles



Fuels

- Fuels from local sunshine and air

A sustainable and environmentally benign water supply

Outline

- **On the needs and means of humanity**
- **Fuels and how to get them**
- **Challenges in solar-thermochemical fuel production**
- **Water and power**
- **Beyond the means of today**

Unsustainable Civilizations...

Food



Water



Energy



Transportation



Resolution?

...Collapse



The “natural” resolution throughout history: conflict, destruction, loss of life...

Is There a Better Future?

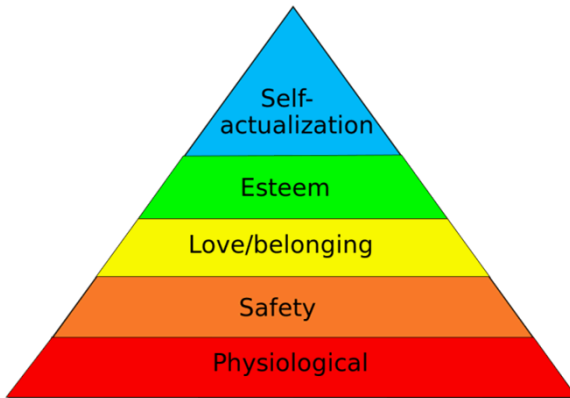
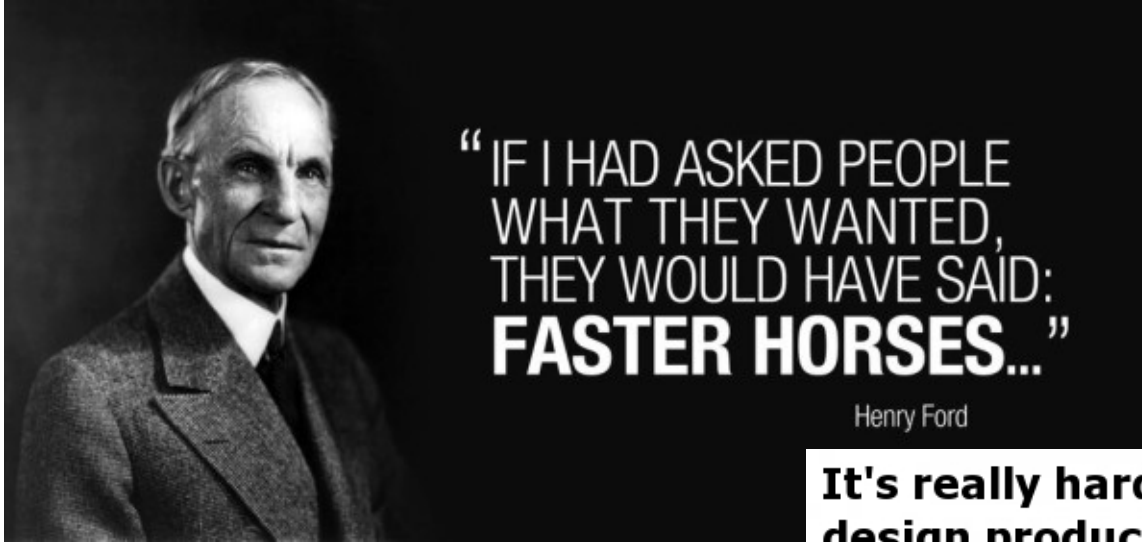

It's really hard to design products by focus groups. A lot of times, people don't know what they want until you show it to them

~ Steve Jobs ~

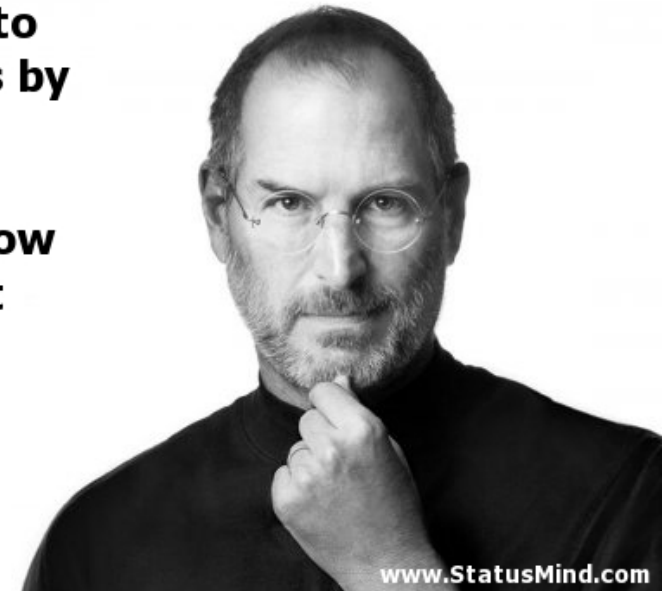

The future will always be different from the past

Is There a Better Future?

Water capture and treatment



Renewable electricity and fuels



Indoor farming, chemosynthesis



Urban design



Efficient transportation



**Conservation,
Conservation,
Conservation...**



Thank you

Thermochemistry: Cement Manufacture

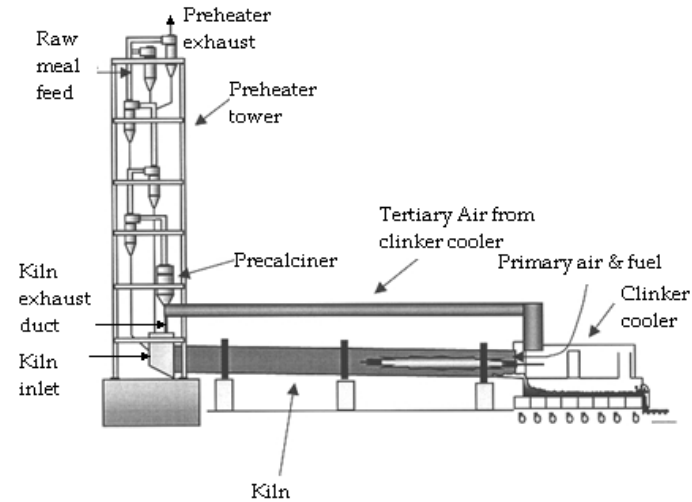
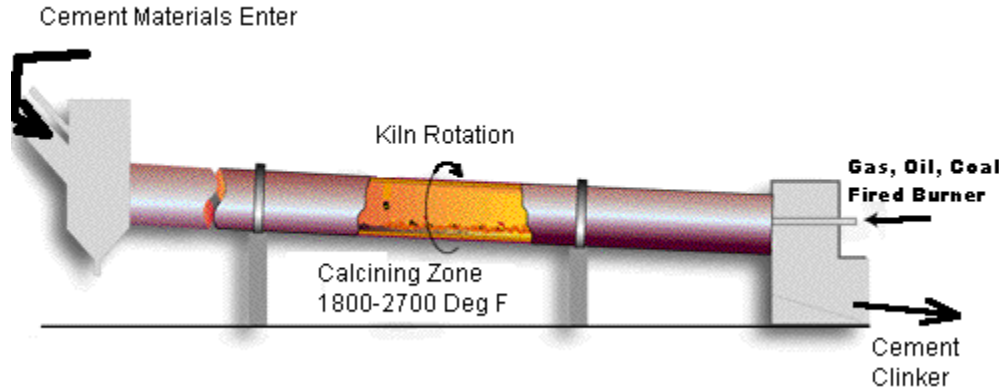

- Operating at 1450°C for years
- Lifts ~15 000 000 kg raw material per day (or about 10 000 kg/min)
- Conducts a thermochemical reaction:
 $\text{CaCO}_3 \rightarrow \text{CaO}$
- Fuel (natural gas) must be purchased and is part of the operating cost

LOWE'S NEVER STOP IMPROVING

Shop Ideas & How-Tos Savings MyLowe's What are you looking for?

Home: Building Supplies - Asphalt, Concrete & Masonry
Concrete & Masonry Products: Concrete Mix: QUIKRETE 80-lbs Concrete Mix

Your Store: Albuquerque, NM

QUIKRETE 80-lbs Concrete Mix
Item #: 10385 | Model #: 110180
★★★★★ 230 reviews | Write a review

\$3.48
Was: \$3.99
Save 12%

High-Temperature Tech: Gas Turbines

Heat engines are inexpensive, even gas turbines:

- High temperature operation – up to 1650°C
- High speed – 10 000 to 500 000 RPM
- High pressure – exceeds 30 MPa

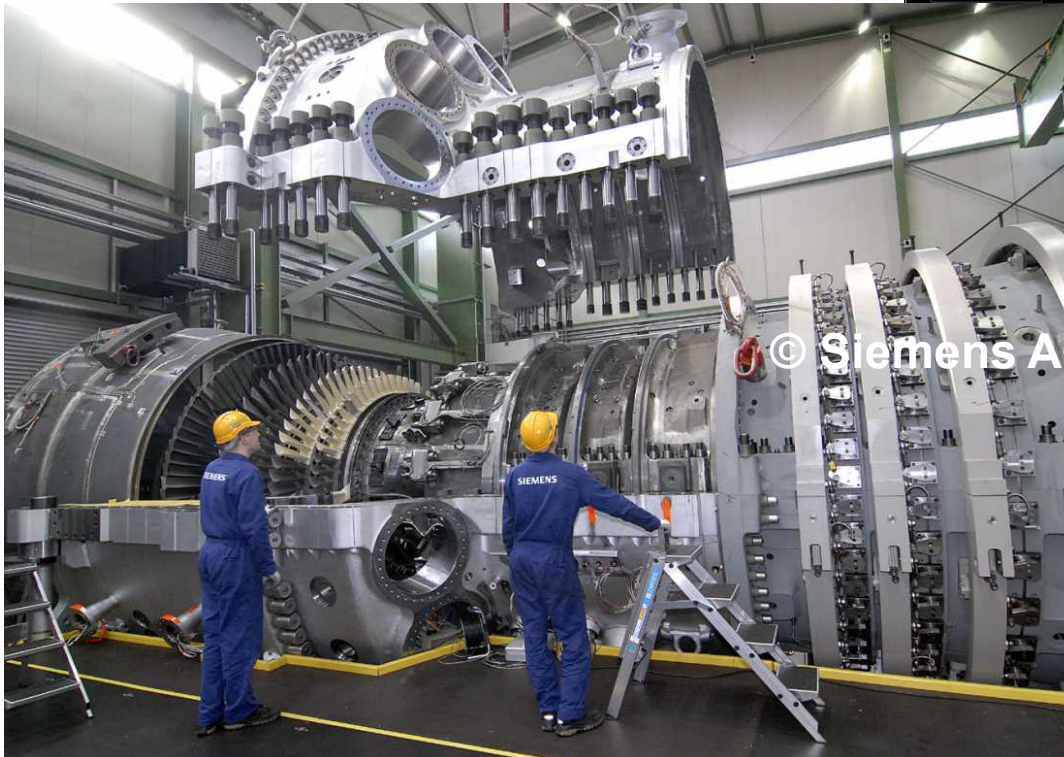

Cost: 18-30 \$/W

Primer

Avy Thermodynamics Corporation

Gas Turbine Prices \$ per KW

These prices were supplied by various purchasers in the year shown. I have no notes as to the auxiliaries if any, were included in these prices. As people send in prices that they've paid for turbines I will add them to the list, and perhaps we will be able to get a more complete picture of the cost per KW of the available choices.

Manufacturer	Model	RPM	Output	Heat Rate	\$ in Million	\$/KW
GE	9281F	3000	217870	9625	39.9	\$183.14
GE	9231EC	3000	173680	9435	32.2	\$185.40
TP&M	FT4C-3F	3600	29810	10875	5.7	\$191.21
GE	9171E	3000	125940	9890	24.5	\$194.54
KWU	V94.2	3000	154000	10065	30.2	\$196.10
GE	9301F	3000	214000	9700	42	\$196.26
GE	9311FA	3000	228195	9360	45	\$197.20
WESTINGHOUSE	701D5	3000	133750	9960	26.5	\$198.13
WESTINGHOUSE	701DA	3000	138520	10040	27.5	\$198.53
WESTINGHOUSE	701F	3000	235720	9280	47	\$199.39
GE	9161E	3000	119355	10105	23.8	\$199.41
GE	7191F	3600	151300	9625	30.4	\$200.93
KWU	V94.2	3000	148800	10210	30.2	\$202.96
KWU	V94.3	3000	200360	9550	41	\$204.63
KWU	V94.3	3000	219000	9450	45	\$205.48
WESTINGHOUSE	501 D5	3600	121300	9890	25	\$206.10
WESTINGHOUSE	501 D5	3600	106800	10100	22.1	\$206.93
ABB	GT13E	3000	148000	9855	31	\$209.46
GE	7221FA	3600	161650	9243	34	\$210.33
WESTINGHOUSE	501 D5	3600	109350	10010	23	\$210.33
WESTINGHOUSE	501F	3600	163530	9470	34.5	\$210.97
ABB	GT13E2	3000	164300	9560	36	\$219.11
KWU	V84.2	3600	106200	10124	23.3	\$219.40
ABB	GT13D2	3000	100500	10600	22.5	\$223.88
ABB	GT11N2	3600	109200	10030	24.5	\$224.36
KWU	V84.3	3600	152700	9450	34.5	\$225.93
GE	7111EA	3600	84920	10212	19.3	\$227.27
KWU	V84.2	3600	103200	10220	23.5	\$227.71
GE	7171EF	3600	126200	9990	28.8	\$228.21
KWU	V84.3	3600	139000	9560	33	\$237.41
ABB	GT11N	3600	83880	10370	20.5	\$244.40
ABB	GT11N	3600	81600	10700	20.5	\$251.23
GE	6101FA	5100	71750	9740	18.5	\$257.84
WESTINGHOUSE	251 B10A	5420	42300	10600	11	\$260.05
GE	6541B	5100	39325	10560	10.5	\$267.01
GE	M5382C	4670	28337	11667	7.7	\$271.73