

Exceptional service in the national interest



solar.sandia.gov



Metal Oxide-Based Thermochemical Redox Processes for Producing Solar Fuels and Storing Thermal Energy

Presented by James E. Miller

Sandia National Laboratories
Advanced Materials Laboratory



Sandia National Laboratories is a multi-program laboratory managed and operated by Sandia Corporation, a wholly owned subsidiary of Lockheed Martin Corporation, for the U.S. Department of Energy's National Nuclear Security Administration under contract DE-AC04-94AL85000

Concentrating Solar Power (CSP)

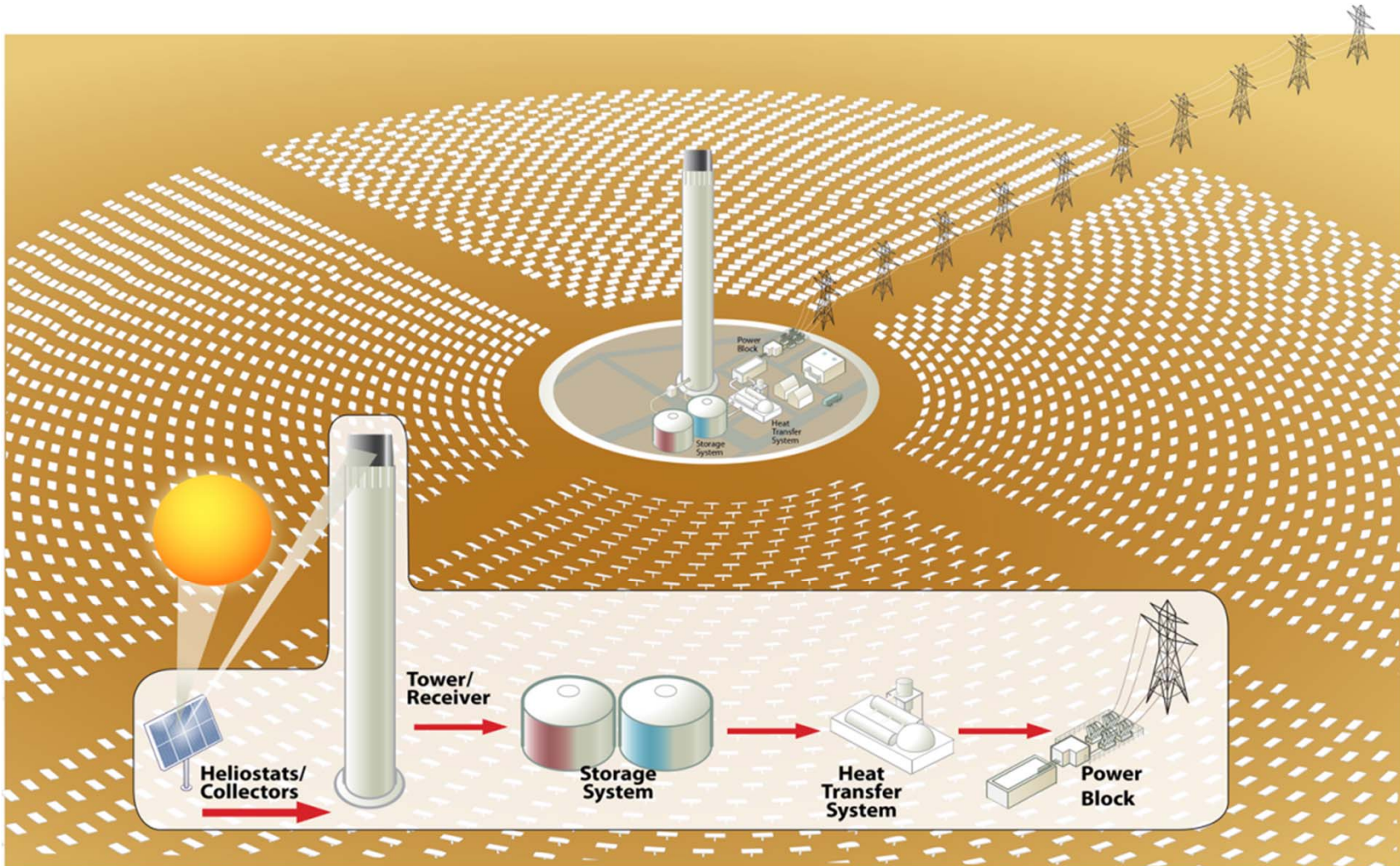

Thermal Energy Storage (TES)

Differentiates CSP from Other RE

- Energy collection is decoupled from power production/delivery
- Shift or extend operating hours
 - Improve capacity factor
 - Decrease levelized cost of electricity (LCOE)
 - Facilitate grid penetration
 - Improve profitability

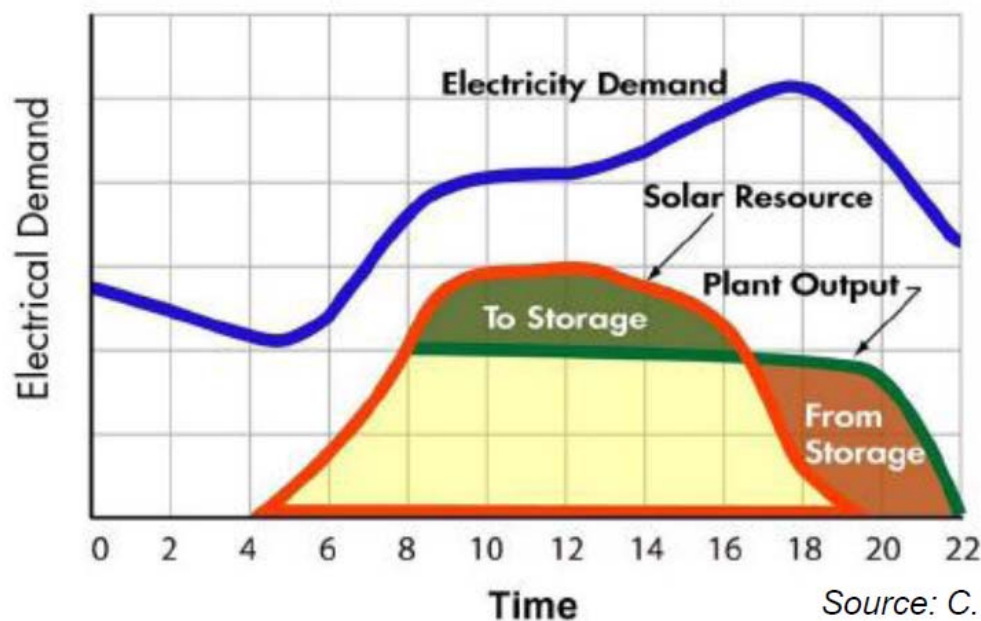

Source: C. Libby, EPRI

Solar Salt
 405 kJ/kg, $T < 650\text{ }^{\circ}\text{C}$

Desirable Thermal Storage Attributes

- High temperatures
- High energy density
- Low cost
- Stability, Longevity
- High 1st and 2nd Law Efficiency
- Simplicity
- Compatibility
- Rapid startup

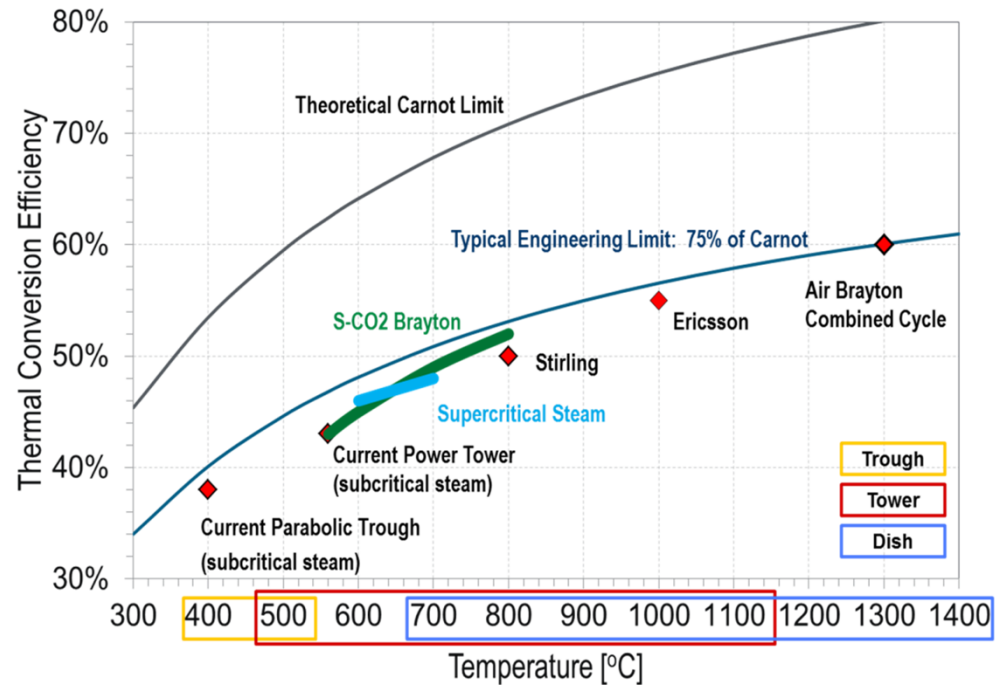

Exergetic Efficiency and Volumetric Energy Density Combinations that Meet the $\leq \$15/\text{kWh}_t$ Cost Target for CSP TCES Systems

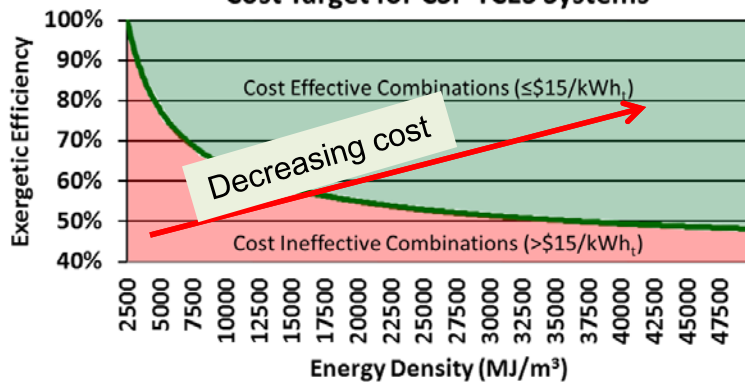

High T is an opportunity for higher efficiency.

High Energy Density is an opportunity to minimize capital costs.

Two Application Spaces – One Solution?

Energy In, O₂ Out.

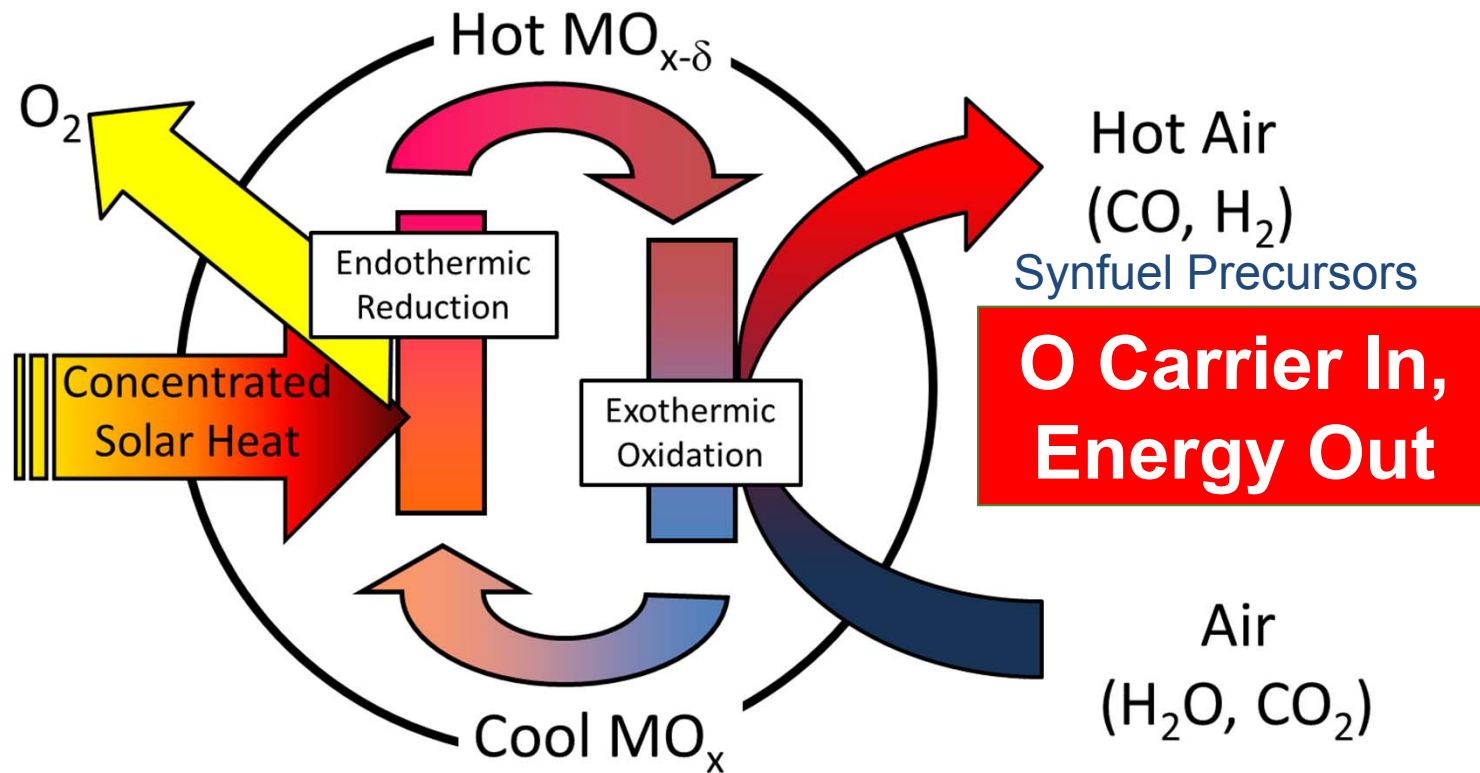

Metal Oxide Thermal Redox Chemistry

CO₂ avoidance and CO₂ utilization

A simple concept: Heat in, Fuel Out

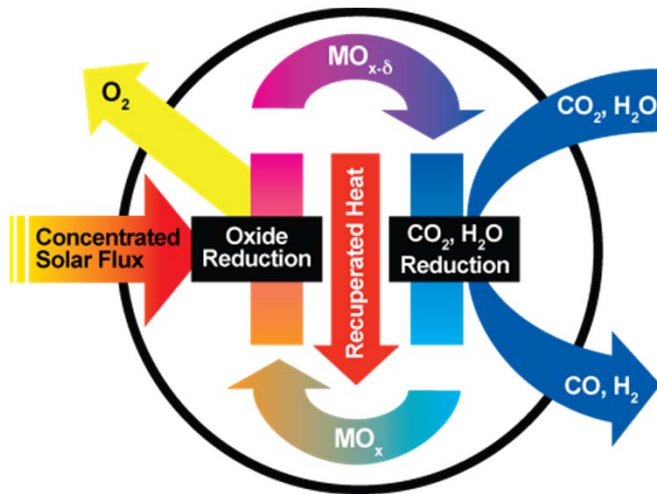
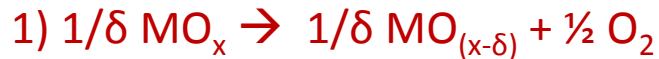

A thermochemical cycle is essentially an engine that converts heat into work in the form of stored chemical energy. ***Efficiency gains are possible as initial conversion to mechanical work and electricity are avoided.***

Goals: Minimize energy required per unit CO and/or H₂ produced; minimize the cost.

Divide an unfavorable endothermic reaction
($\text{H}_2\text{O} \rightarrow \text{H}_2 + \frac{1}{2} \text{O}_2$, or $\text{CO}_2 \rightarrow \text{CO} + \frac{1}{2} \text{O}_2$)
into two thermodynamically favorable reactions.

Potential Solar Fuels Impact:



Meeting a significant fraction of transportation fuel demand with solar fuels is certainly plausible!

- *High solar to fuel efficiency (>10% Annual Average) is absolutely required.*
 - Cost
 - Scale (land, materials of construction (embedded energy))
- *Water, CO₂ are not limiting –*
 - Water consumption/cost relatively low (water rights?)
 - High impact opportunity for CO₂ utilization – long term requires air capture.
- *Consistent with other human activities occurring over multiple decades.*

E.B. Stechel and J.E. Miller “Re-energizing CO₂ to fuels with the sun: Issues of efficiency, scale, and economics” *Journal of CO₂ Utilization*, 1 (2013) 28–36.

Solar Thermal Heat In, Fuel Out

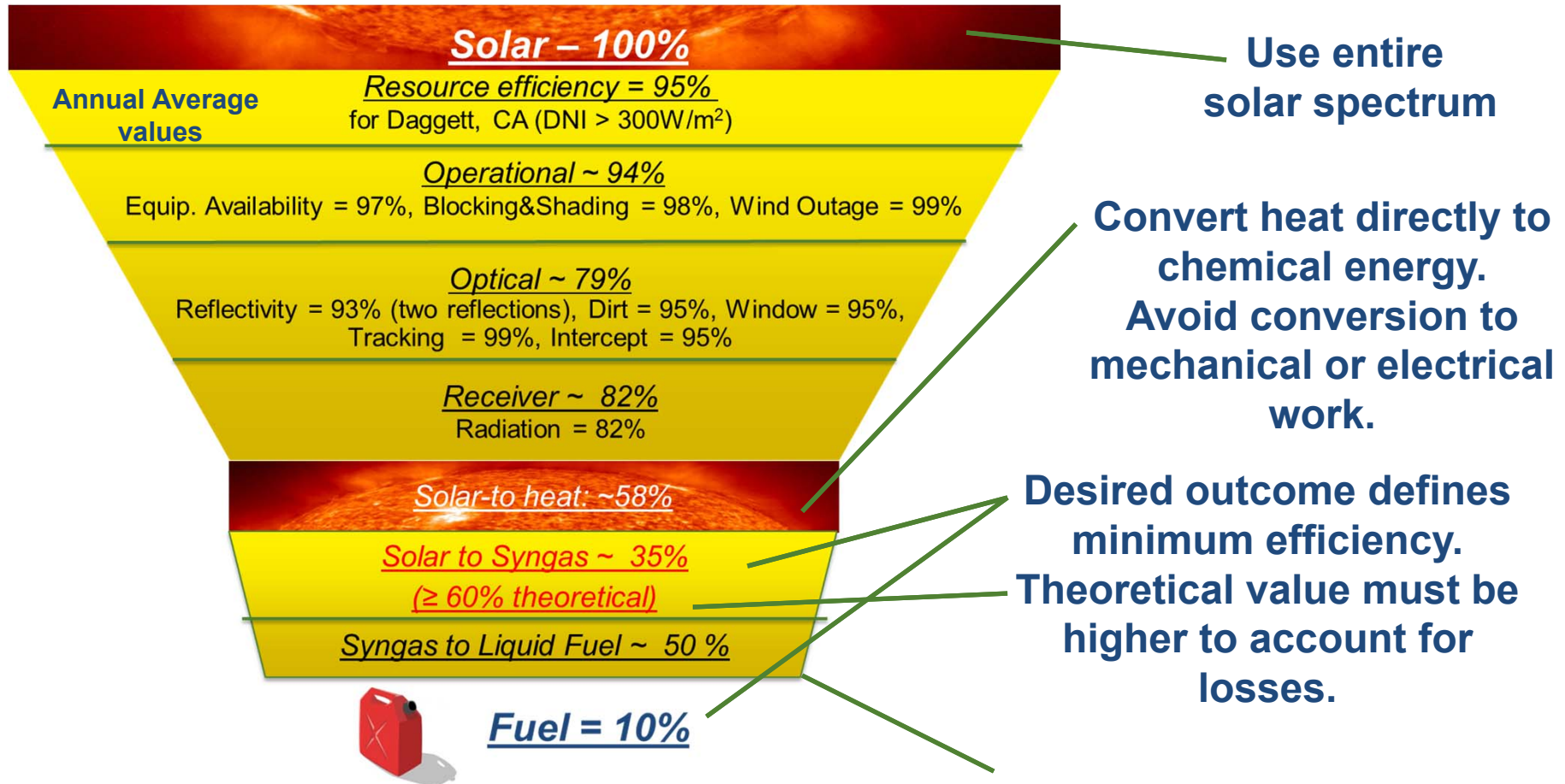

Capitalize on decades of Synfuel technology, e.g.

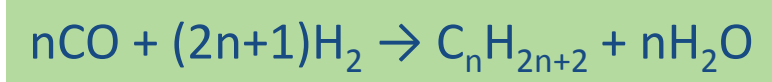

The thermodynamic cost implementing a reaction as a cycle

$$\Delta H_{\text{red endotherm}} - \Delta H_{\text{oxid exotherm}} = \Delta H_{\text{fuel}}$$

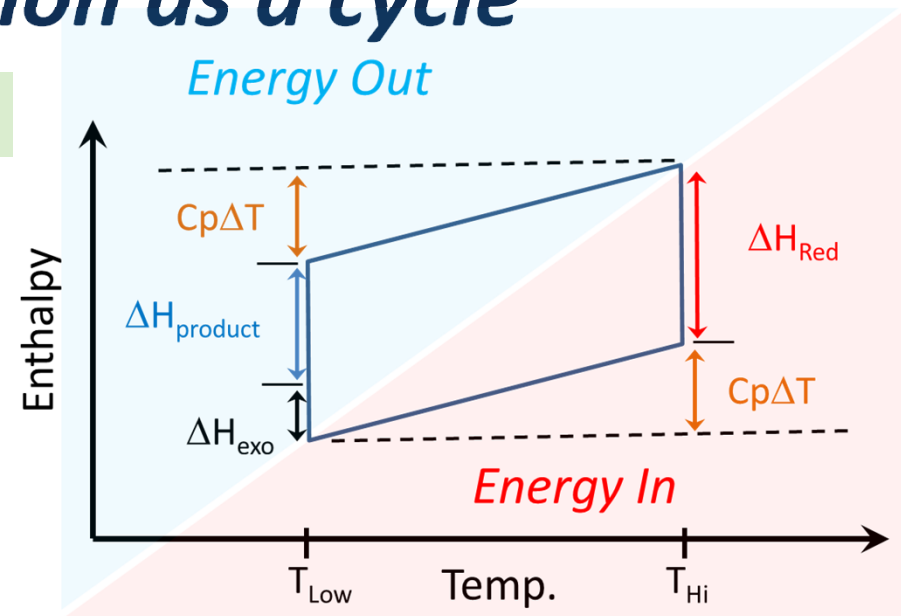
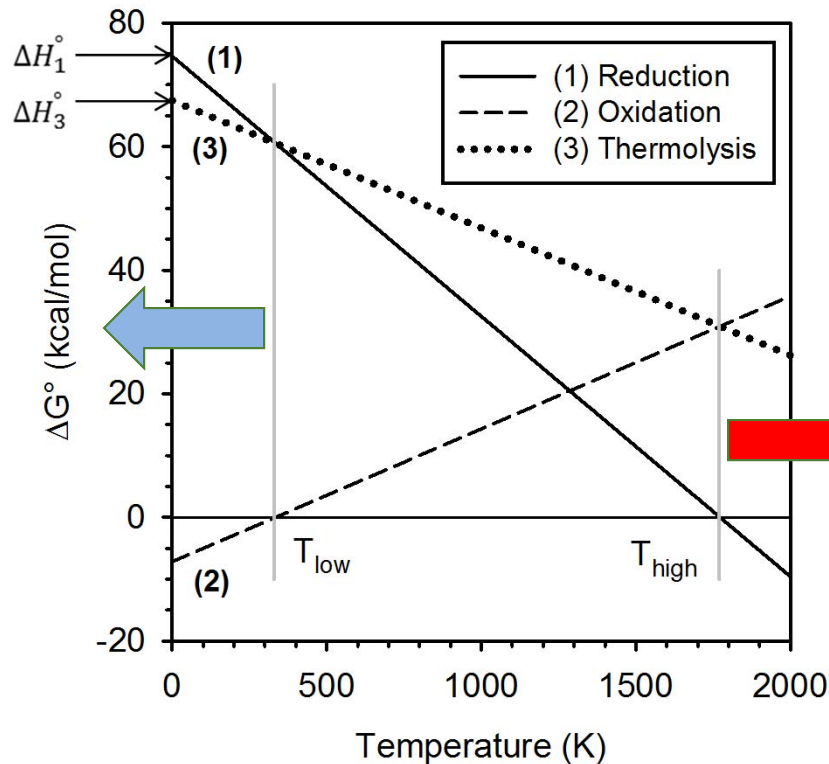

$$\frac{\Delta H_{\text{fuel product}}}{\Delta H_{\text{red}} + (C_p \Delta T)_{\text{net}}} = \text{Max. thermal eff.}$$

- Each reaction favorable at a different temperature (arrows)
- Some heat will be rejected as an exotherm
- Temperature gap and exotherm are a function of the active material

Heat of reaction and thermodynamically defined temperatures.

Materials with high reduction temperature, low oxidation temperature (wide spread) minimize reduction enthalpy. Sensible heat considerations favor a narrow spread.

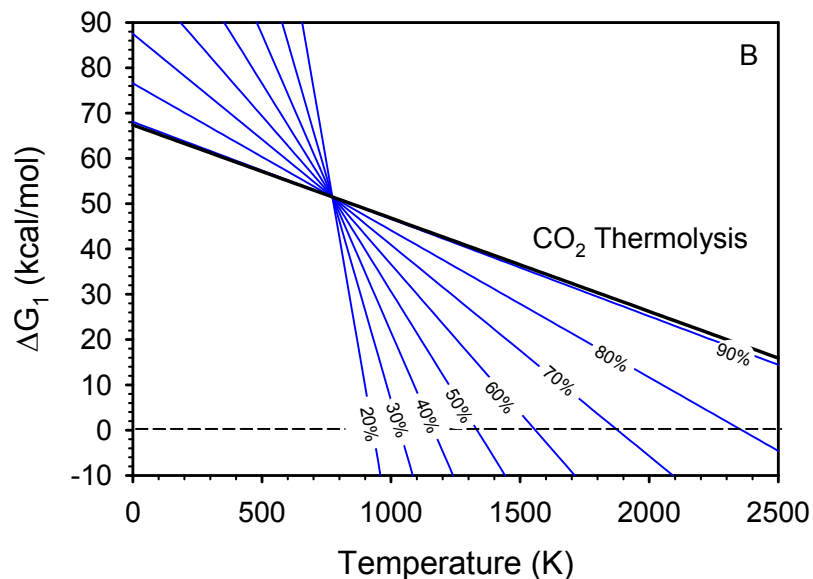

Note: these use a slightly lower “fuel cell-like” efficiency

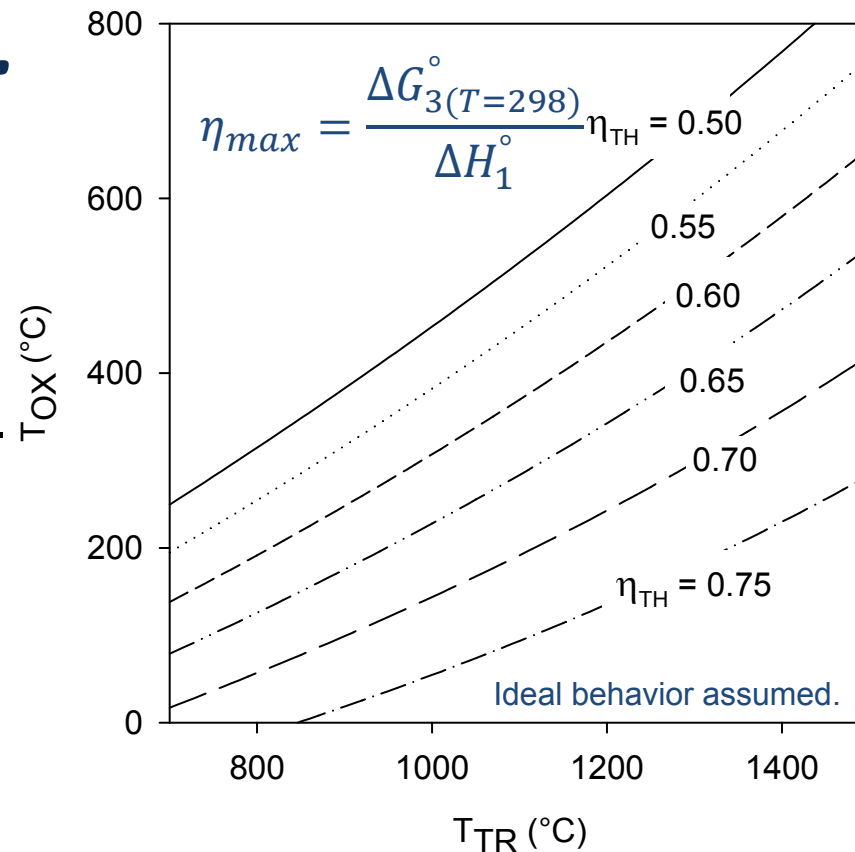

Thermodynamic T_{TR} and T_{OX} imply ΔH and ΔS and vice versa. Not all combinations are realistic.

Reaction Extent and the Utilization Factor

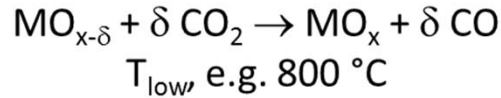
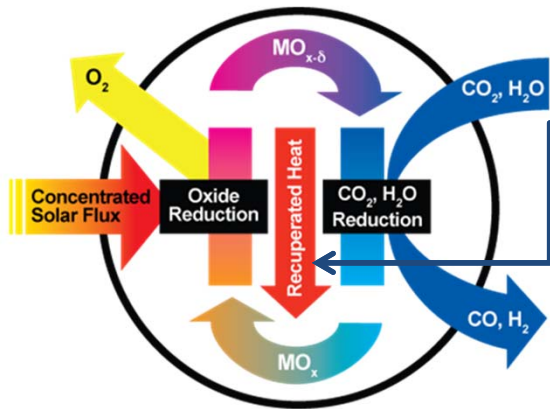
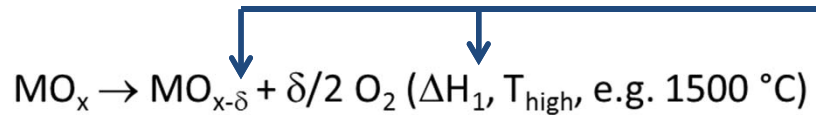

The possible efficiency increases with degree of reaction (δ) and/or effectiveness of recuperation.

When utilization is low, sensible heat demand becomes a more dominant factor than ΔH_1 .

Efficiency is a function of:

Thermodynamics: ΔH_1 (T_{high} & T_{low}), δ

Kinetics: δ

The reactor: recuperation effectiveness & Pressures, sweep etc. (work input)

The maximum possible efficiency is limited by ΔH_1 .

High efficiency (small ΔH_1) corresponds to a large $T_{\text{high}} - T_{\text{low}}$.

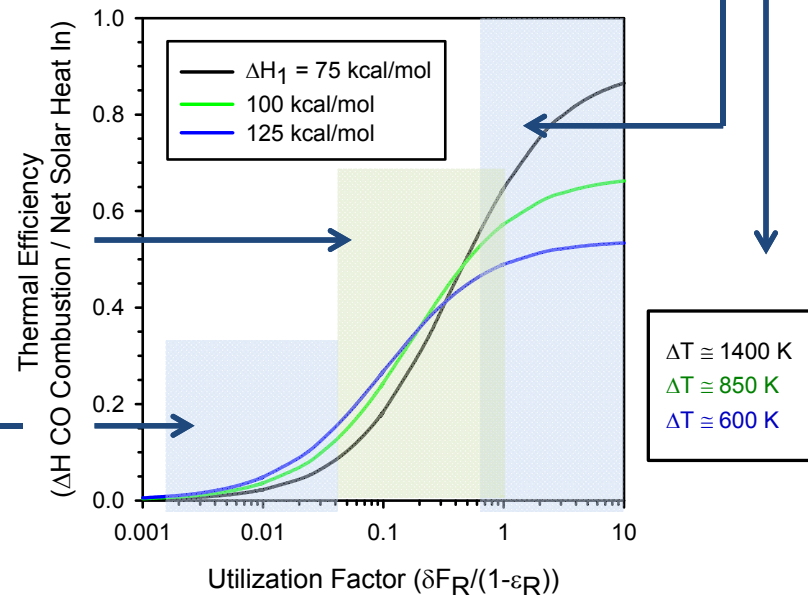

“Non-standard” Temperatures?

Reduction: Work in the form of Pumping or sweep gas shifts reduction temperature.

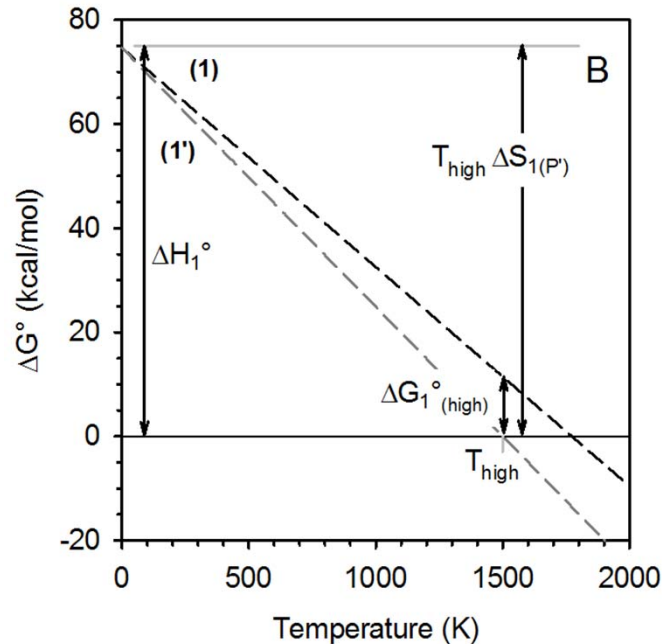

Heat to Work Conversion Penalty

Oxidation:
 $\Delta G \approx -RT \cdot \ln\{[CO]/[CO_2]\}$

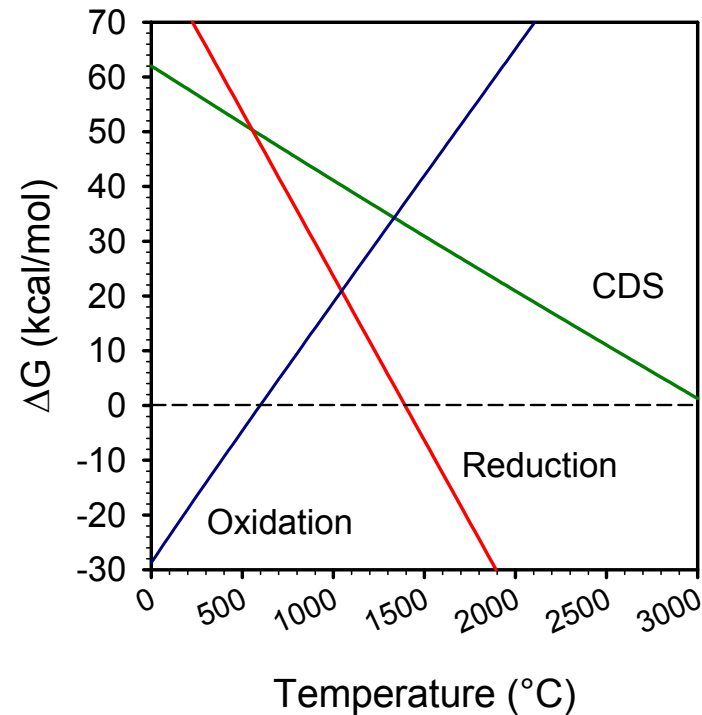

Separation Work Requirement

Yes, but at a price!

$$\frac{\Delta H_{\text{fuel product}}}{\Delta H_{\text{red}} + (C_p \Delta T)_{\text{net}} + Q_{\text{parasitic}} + W/\eta} = \text{Thermal eff.}$$

Optimum Temperature Swing

Balancing thermal losses from T swing and other inputs

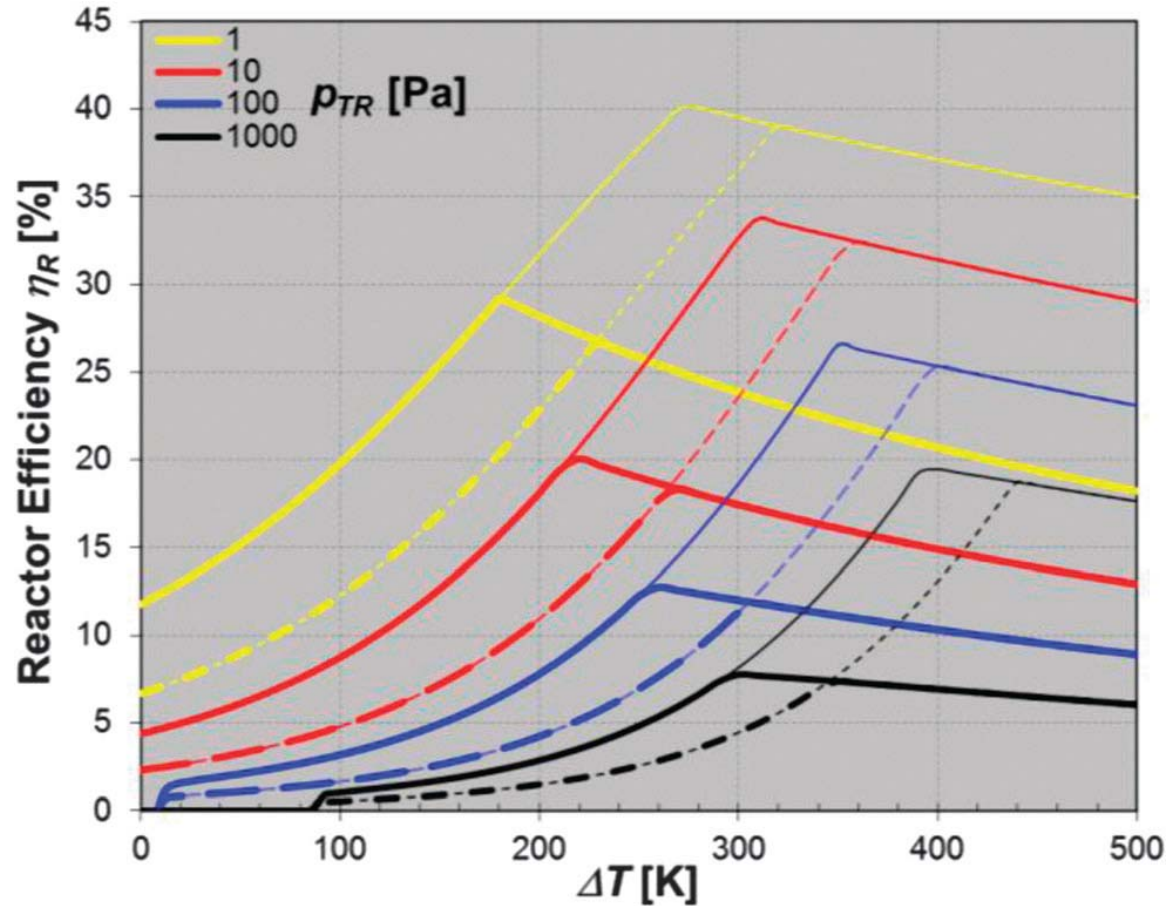

Different lines of similar color represent different recuperation extents for gas and solid for a given material.

Isothermal is possible, but inadvisable

CR5 : First-of-a-kind approach and our attempt to apply the lessons.

Counter-Rotating-Ring Receiver/Reactor/Recuperator (CR5)

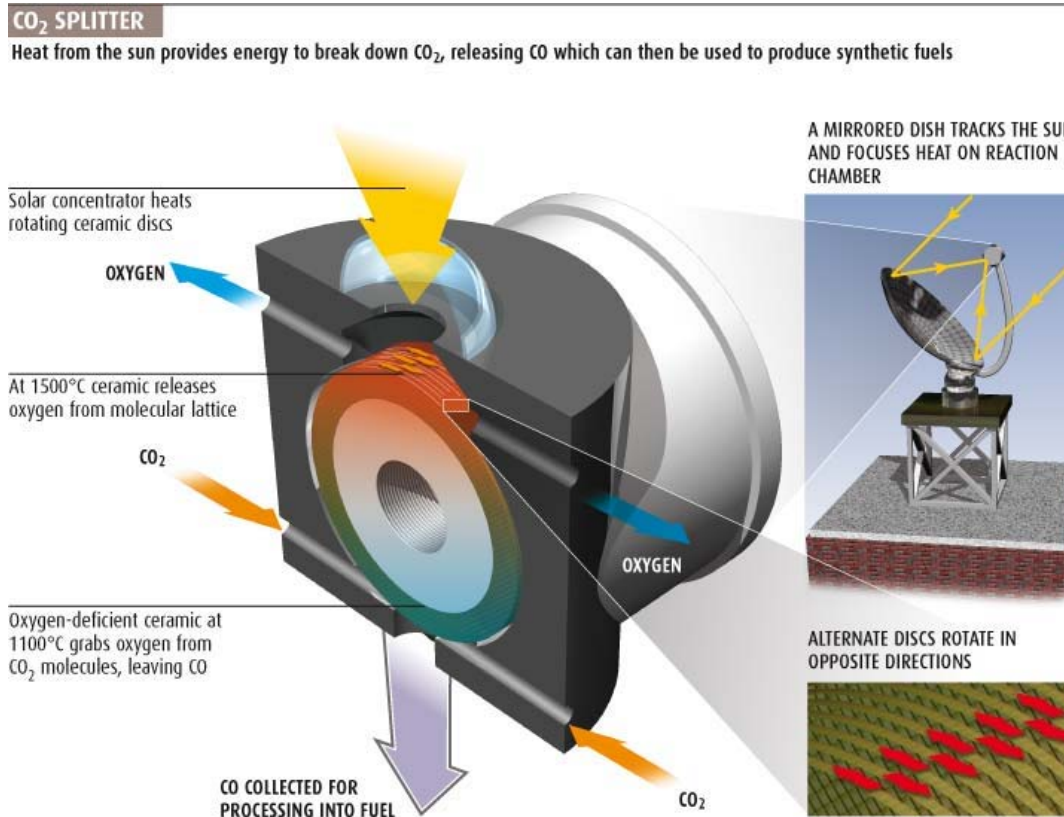

“Reactorizing a Countercurrent Recuperator”

Continuous flow, Spatial separation of products, Thermal recuperation

Performance Map of Gen-1 Prototype

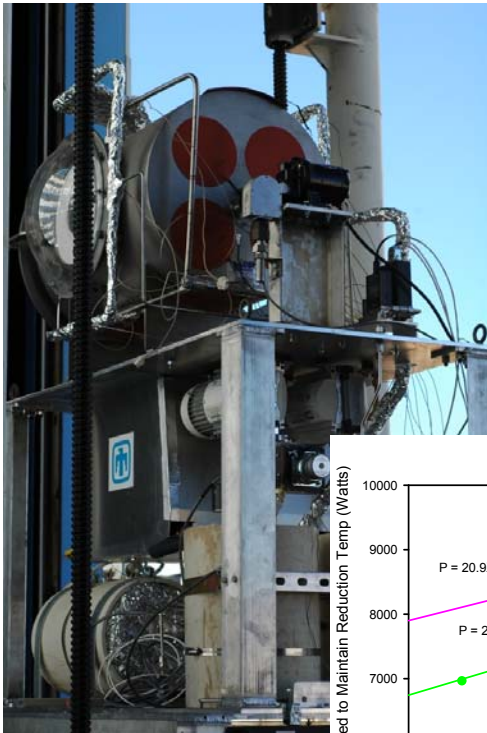

Collect data to validate models, guide improvements

- Ceria-based fins on rings
- 6 Data Sets: Cold, 2@ 1450 °C, 2@ 1550 °C, 1620 °C
- 3 ring rotation speeds, 3 CO₂ flow rates for each
- Constant Ar flow, Pressure = 0.5 atm
- Floating Pressure at 1550 °C

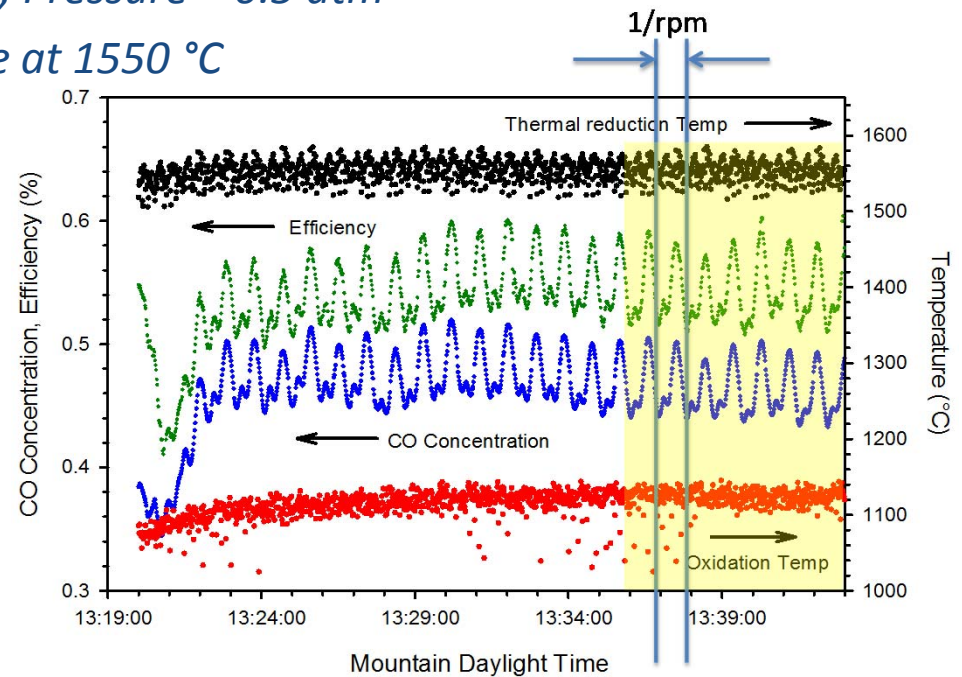
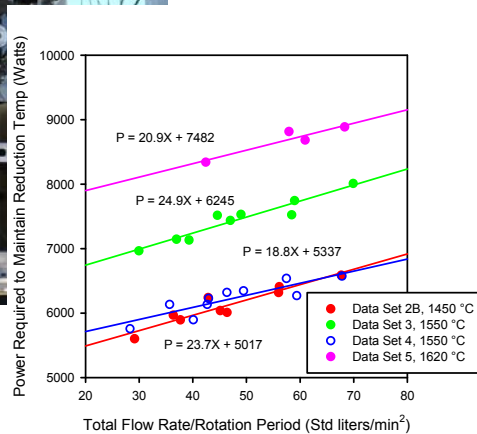

Miller, Allendorf, Ambrosini, Coker, Diver, Ermanoski, Evans, Hogan, McDaniel
 "Development and Assessment of Solar-Thermal-Activated Fuel Production: Phase 1
 Summary" SAND2012-5658, July 2012

For Your Viewing Pleasure ...

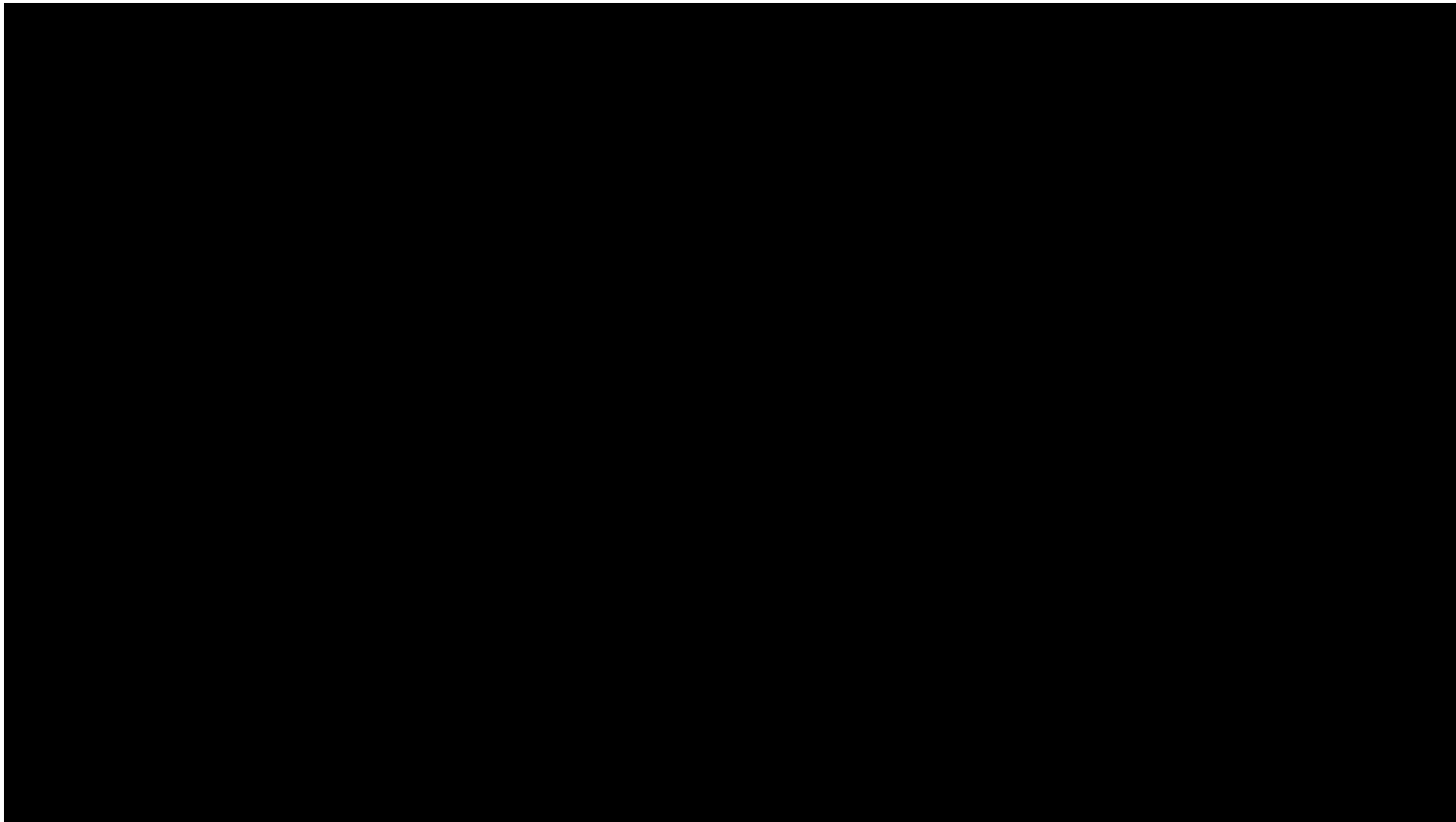

Operating with 22 Rings



Multiple Technical Challenges

Exploiting complex materials and systems to carry out highly coupled, multi-scale (time, dimensions) dynamic processes under extreme conditions.

■ Reactors

- Maximizing energy usage, Minimizing parasitic work input
- Interfacing solar with chemistry
- Decoupling steps

■ Materials

- Simple repeatable chemistry
- Efficient mass and volumetric usage
 - Favorable thermodynamics
 - Rapid kinetics
- Chemical and Physical Durability
 - 1000s if not 10^6 cycles
 - High melting, Low volatility, Sinter resistant

■ Systems

- Setting targets, process optimization , economics, life cycle impacts etc.

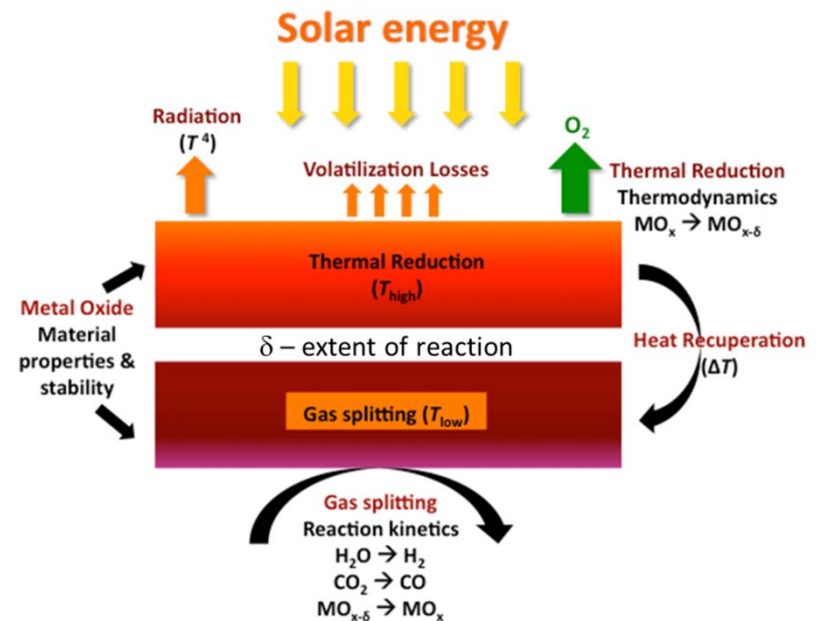

Multiple Technical Challenges

Exploiting complex materials and systems to carry out highly coupled, multi-scale (time, dimensions) dynamic processes under extreme conditions.

■ Reactors

- Maximizing energy usage, Minimizing parasitic work input
- Interfacing solar with chemistry
- Decoupling steps

■ Materials

- Simple repeatable chemistry
- Efficient mass and volumetric usage
 - Favorable thermodynamics
 - Rapid kinetics
- Chemical and Physical Durability
 - 1000s if not 10^6 cycles
 - High melting, Low volatility, Sinter resistant

■ Systems

- Setting targets, process optimization , economics, life cycle impacts etc.

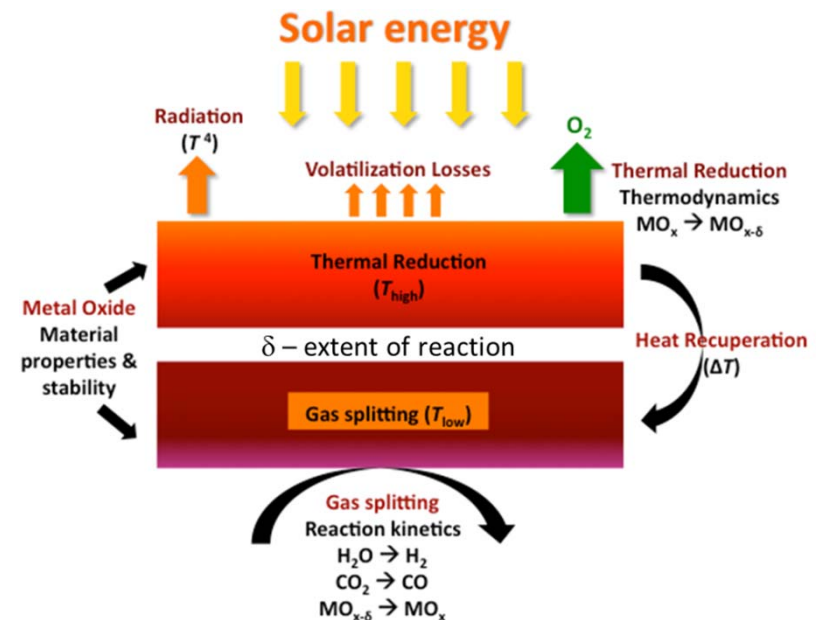

Metal Oxide TC Begins with Ferrites

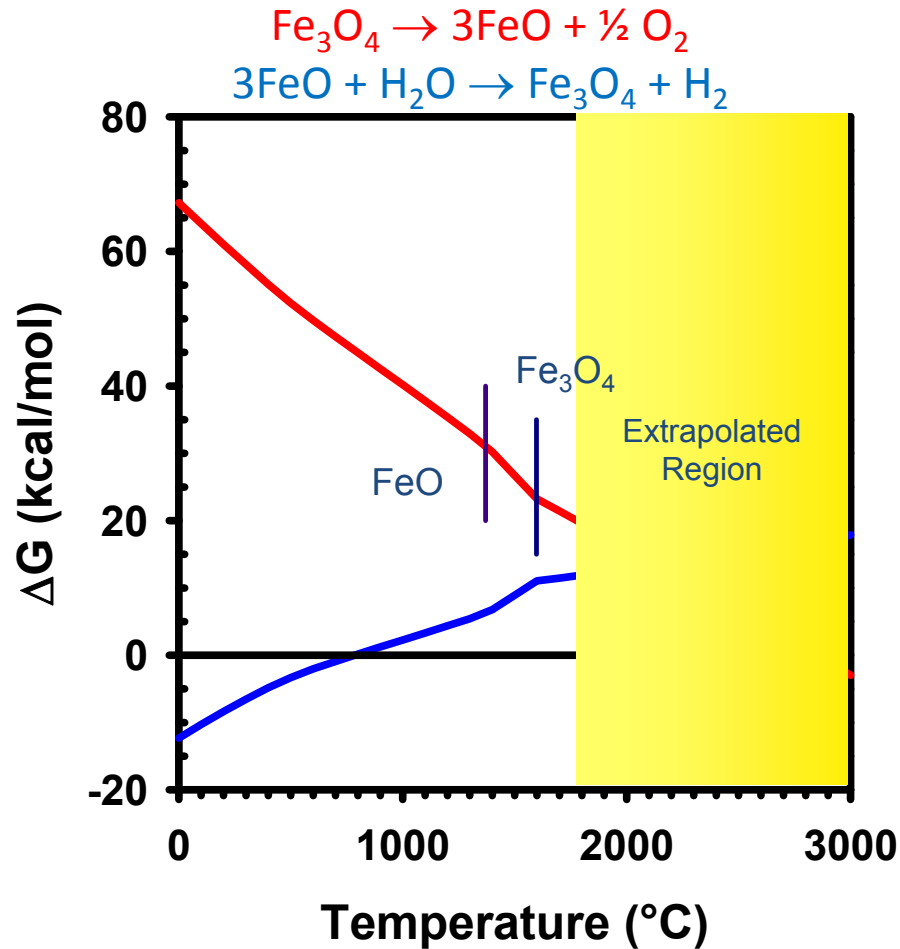

Ferrite metal oxide cycle (Nakamura 1977).

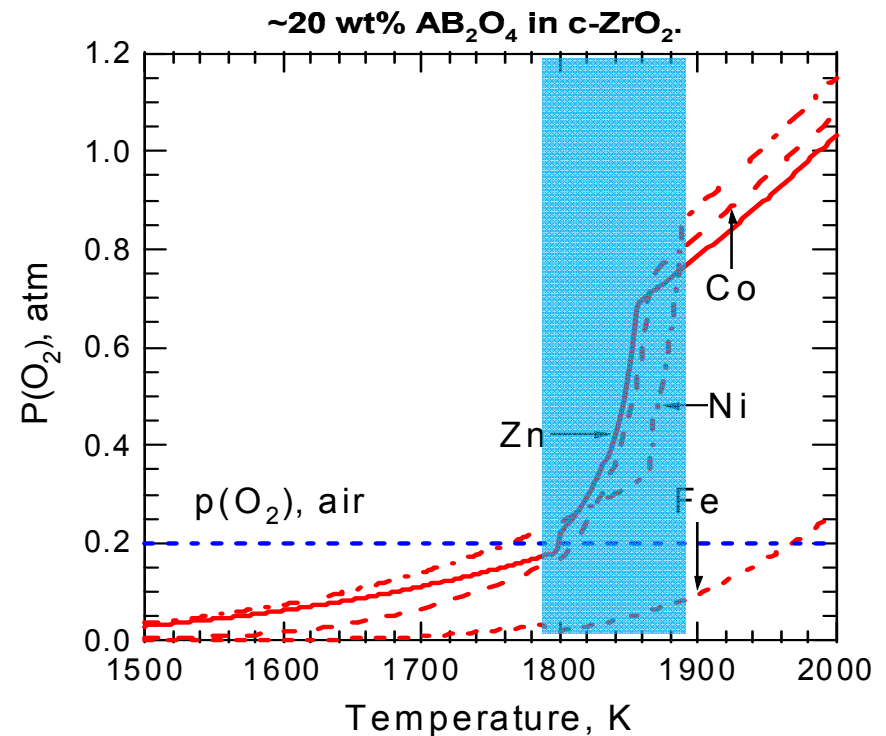

Favorable temperature range (thermodynamics) can be manipulated via metal substitutions in Fe_3O_4 .

Partial conversion now possible.

Metal Oxide TC Begins with Ferrites

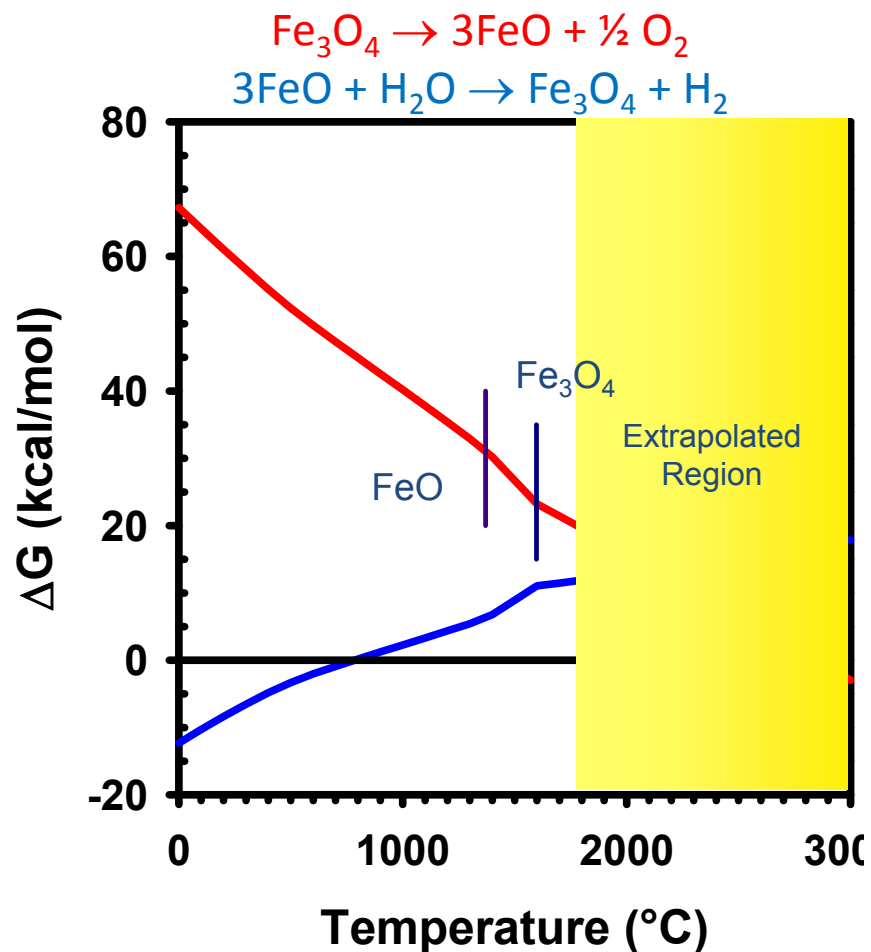

Ferrite metal oxide cycle (Nakamura 1977).

“Bulk” doped ferrites do not live up to thermodynamic expectations

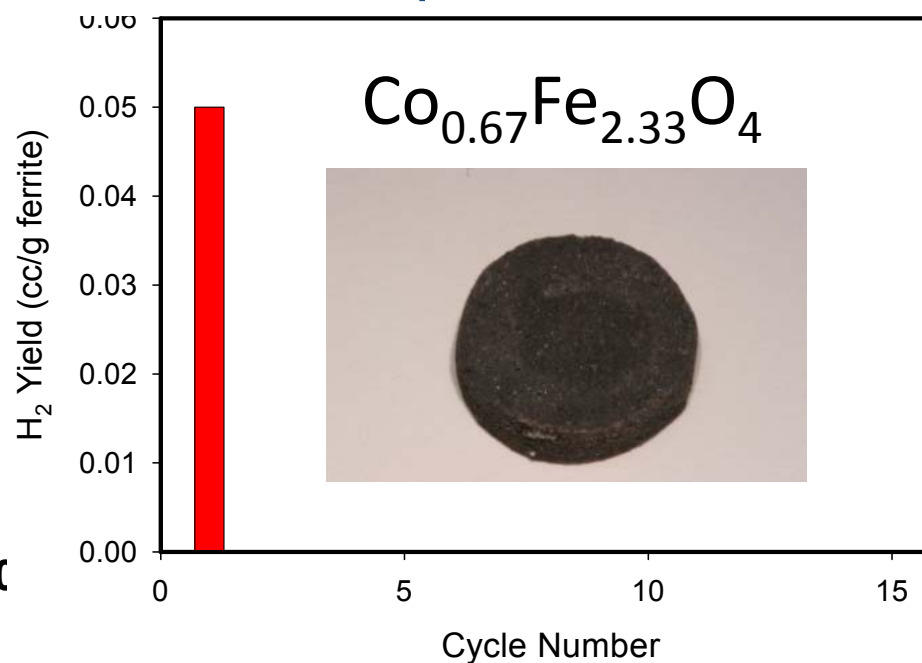

Porous disk of cobalt ferrite produced small amount of H_2 for only one cycle.

Ferrites work ...

when you add Zirconia

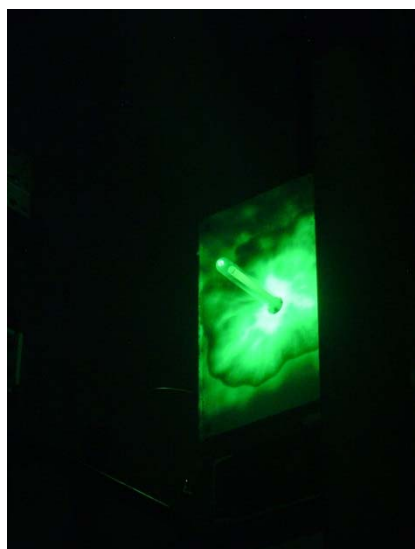
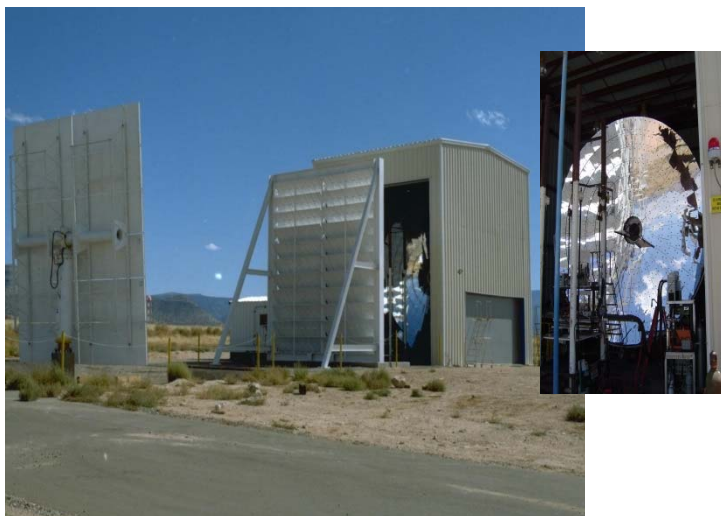

On-Sun Test:
 $\text{Co}_{0.67}\text{Fe}_{2.33}\text{O}_4/\text{YSZ}$ (1:4)

T_{TR} 1580 °C, T_{OX} 1050 °C
 $\text{H}_2 = 3.5\text{-}4$ sccm/g ferrite each cycle

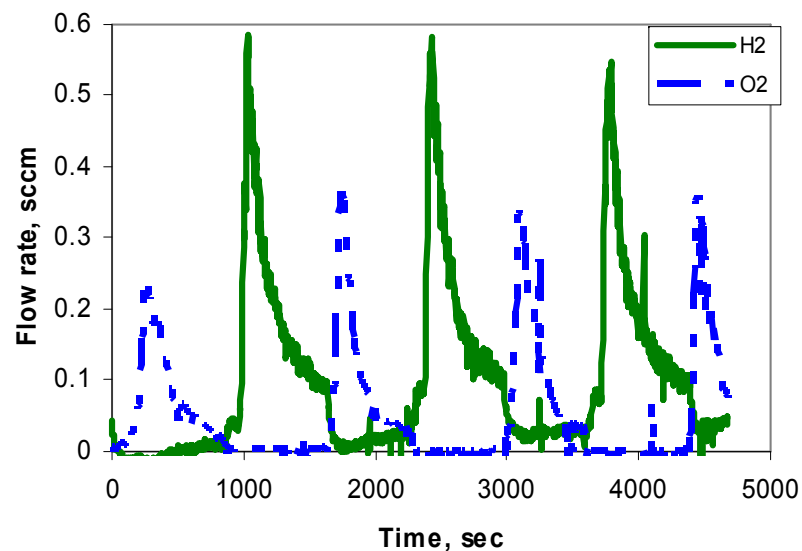

Pioneered by Kodama et. al. (ISEC) 2004, ISEC2004-65063, Portland, OR.

Fe dissolution and oxygen transport are the keys

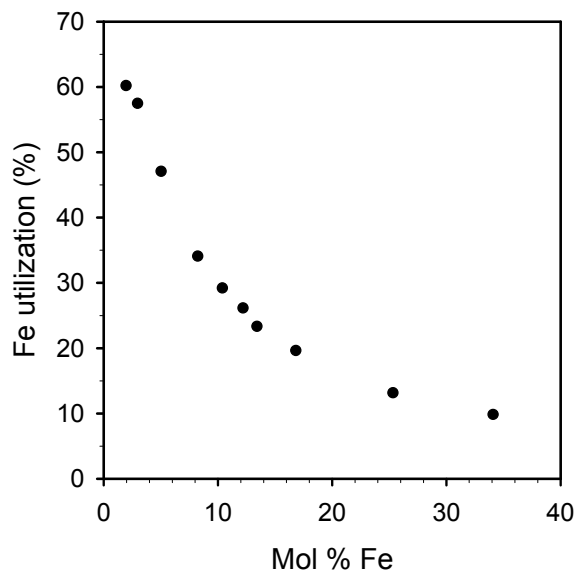
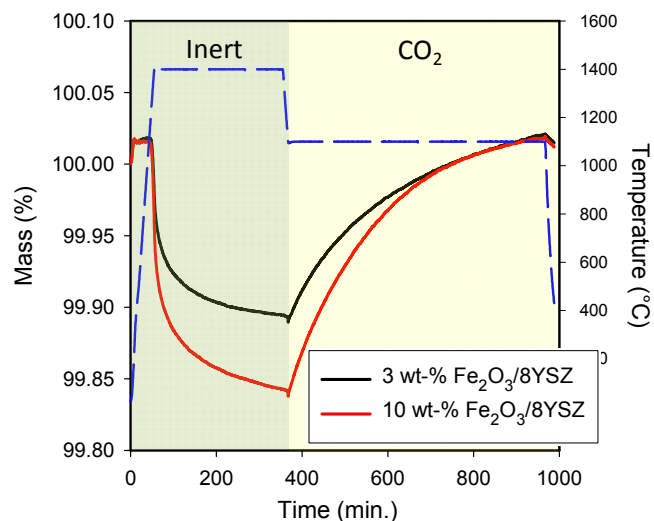

Beyond the solubility limit additional Fe contributes little to the overall gas yield.

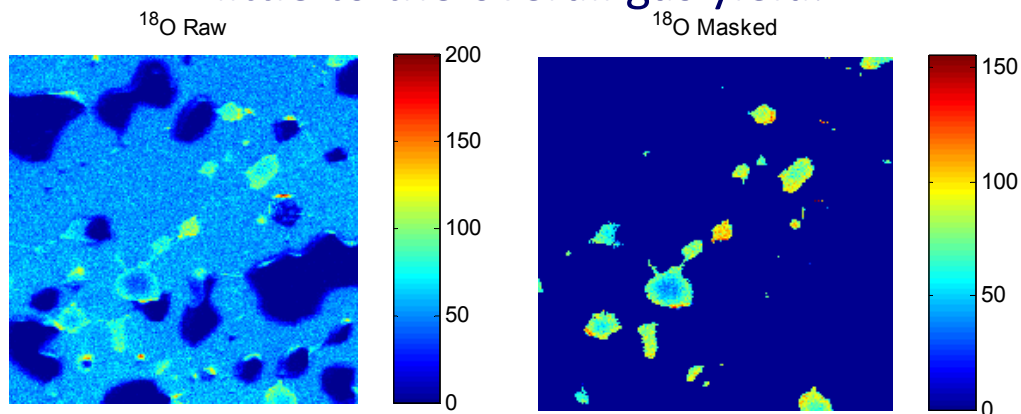

Reaction with ^{18}O -labelled CO_2 confirms limited utilization of bulk particles relative to Fe/YSZ.

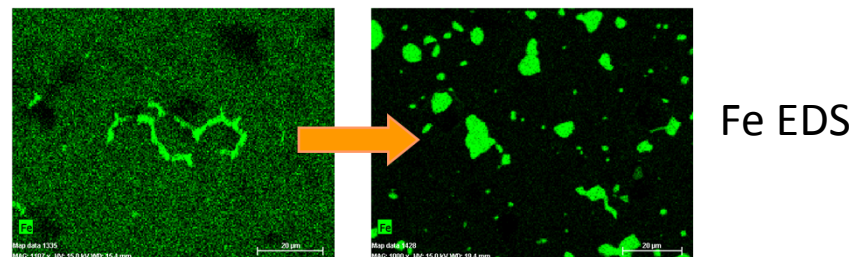

Perspective on Ion Transport

$$\text{diffusion length} = 2\sqrt{Dt}$$

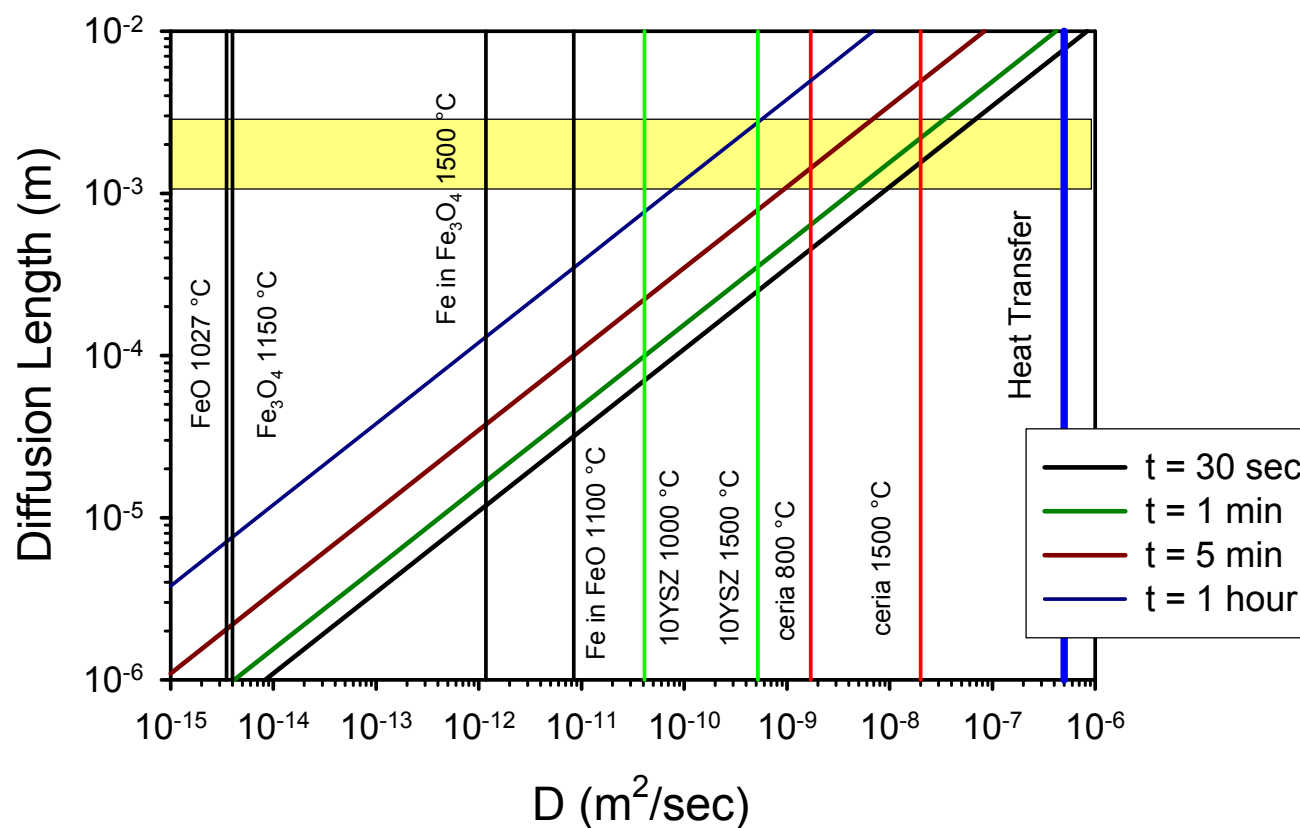

Heat > Ceria > YSZ >> Fe_3O_4

Ion (oxide) diffusion lengths are materials- and temperature-dependent.

Match Dimensions to Transport?



ALD thin film peak production rate ~ 100X faster than bulk

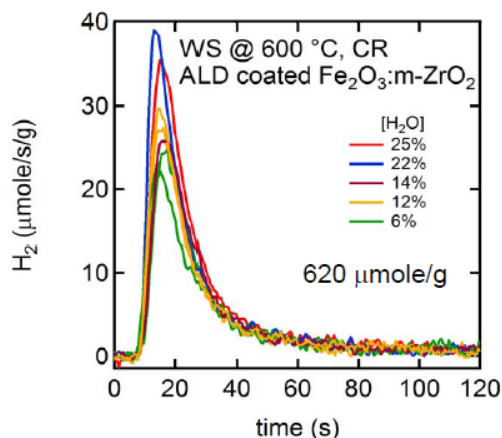

*Chemically reduced ALD
Fe:ZrO₂ nanoparticles*

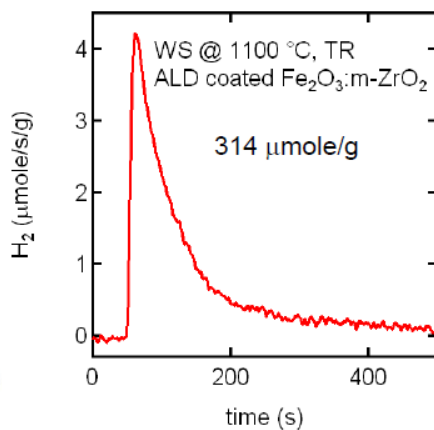

*Thermally reduced
ALD particles*

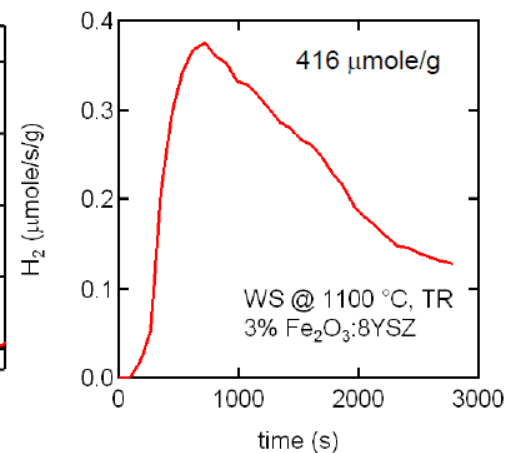

Bulk Fe:YSZ



- CO₂-splitting activity improves dramatically for particles of ZrO₂ coated with *nanometer scale* layers of Fe₂O₃

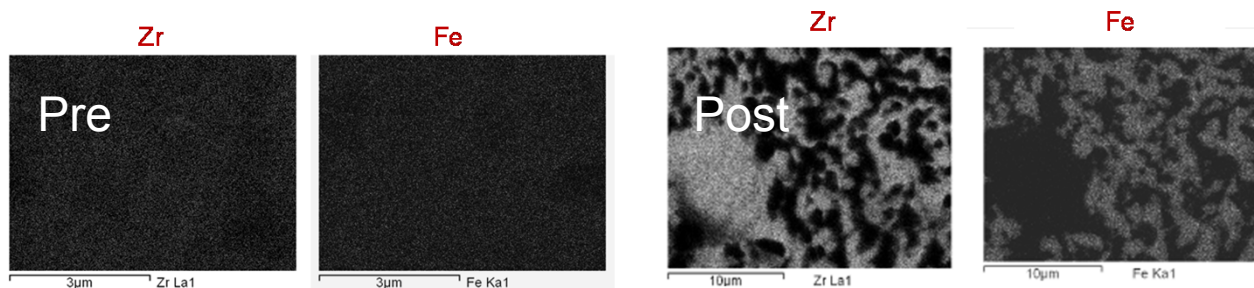

JR Scheffe, MD Allendorf, EN Coker, BW Jacobs, AH McDaniel, AW Weimer
Chemistry of Materials 23 (8), 2030-2038.

Ceria: good transport, poor reaction extent

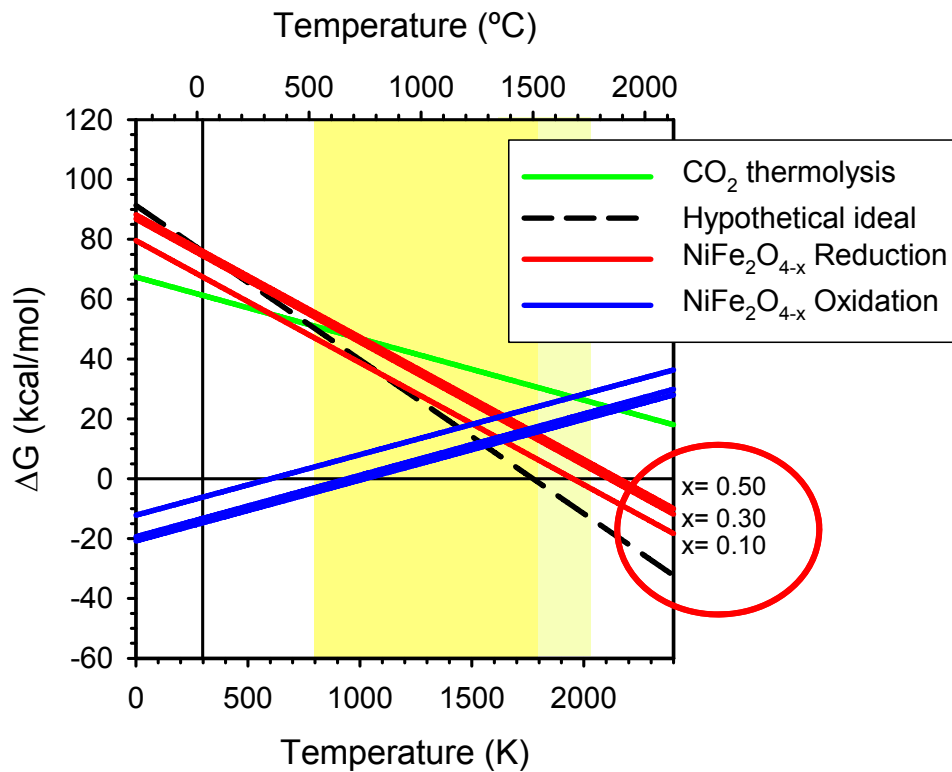

From a thermodynamic viewpoint, ferrites are superior to ceria (larger δ in target temperature range).

ΔH and ΔS (ΔG) are functions of redox state (δ or x). With each increment of reduction, materials become harder to reduce, easier to oxidize.

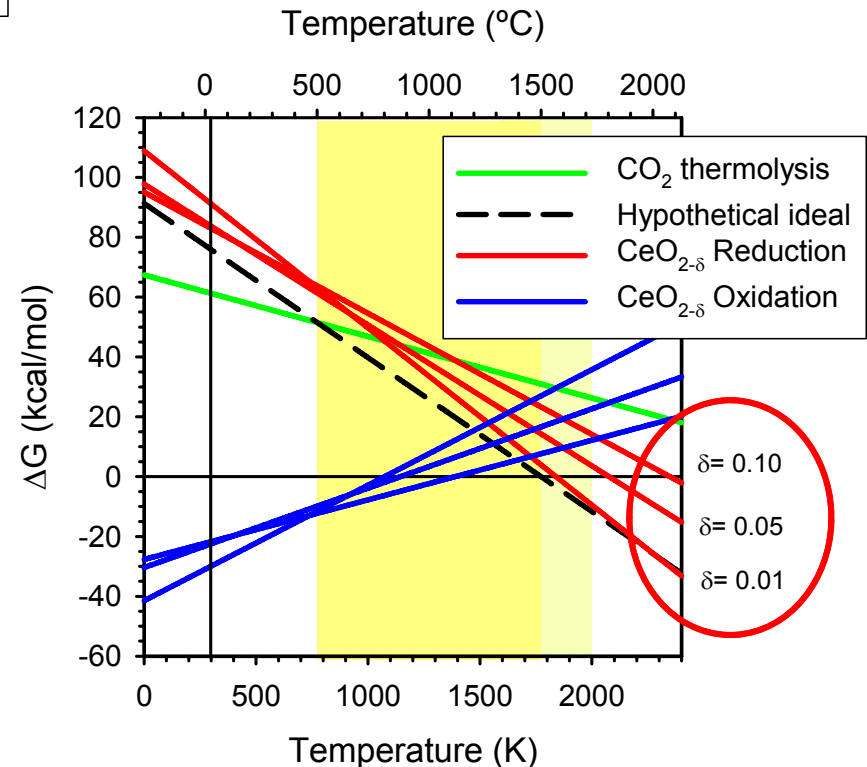

Miller, McDaniel, Allendorf *Adv. Energy Mater* 2013.

One Path Forward: Tailored Materials for



Thermo and Transport

- $\text{La}_x\text{Sr}_{1-x}\text{Al}_y\text{Mn}_{1-y}\text{O}_{3-\delta}$ (LSAM) oxidize to split H_2 and CO_2 with lower T_{TR}
- Comparable kinetics to ceria, but higher utilization.

9× more H_2 , 6× more CO

compound	CO ($\mu\text{mole/g}$)	H_2 ($\mu\text{mole/g}$)
LSAM1	294	307
LSAM2	286	277
LSAM3	247	220
$\text{CeO}_{2-\delta}$	46	32

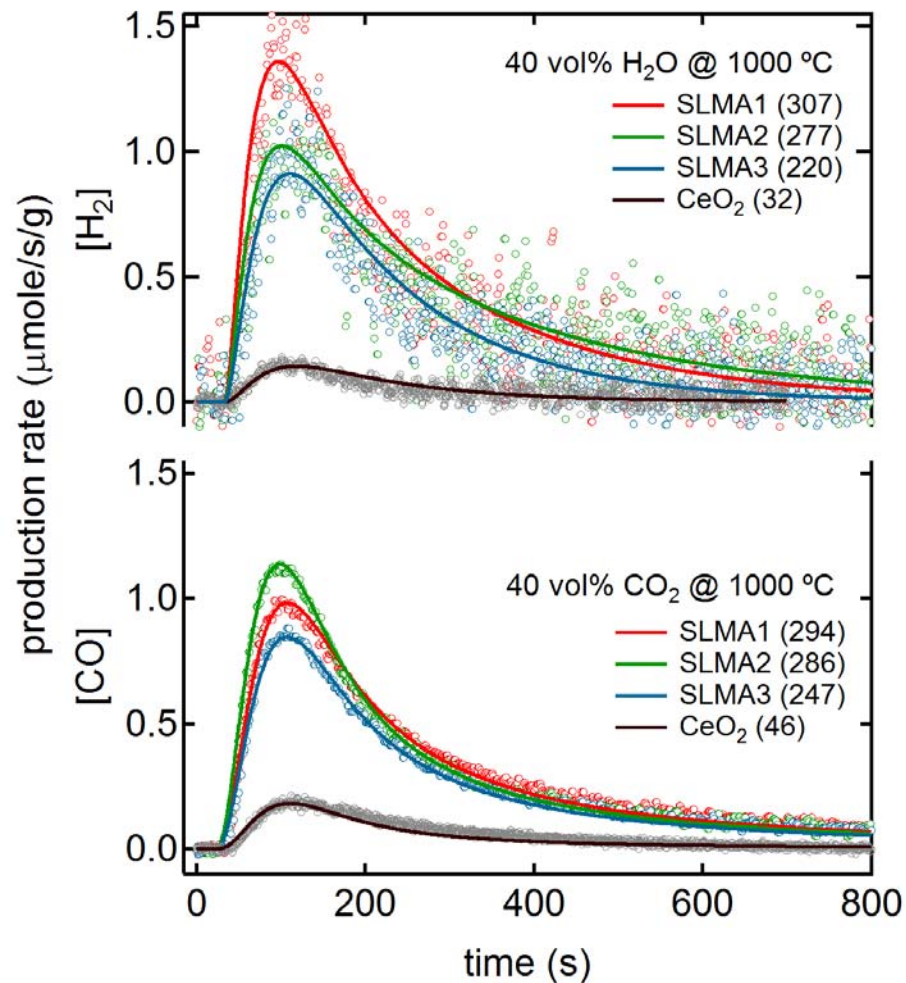

80 cycle durability demonstrated

... Also a path forward for TCES

Goal: Decrease costs of storage while enabling more efficient power and cost effective cycles.

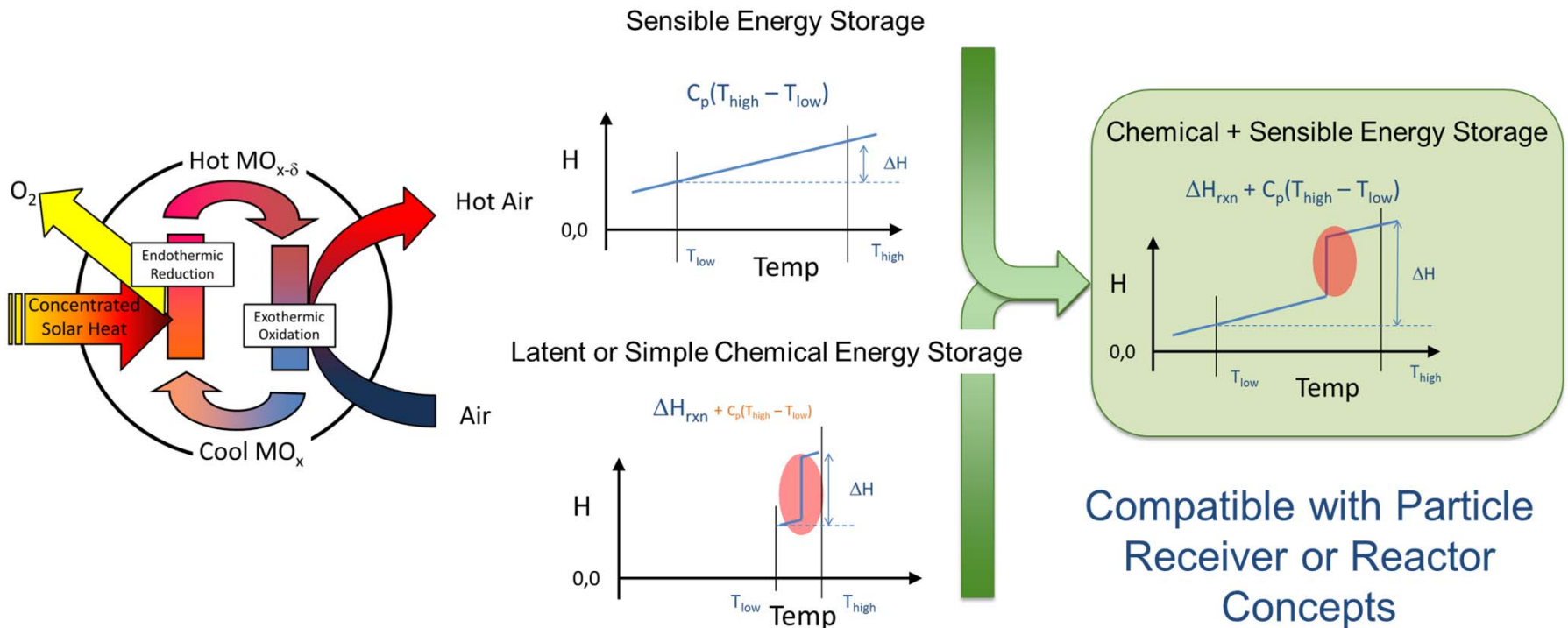

TCES: Single Reversible Reaction
 $2/\delta MO_x \leftrightarrow 2/\delta MO_{x-\delta} + O_2(g)$

Improve Upon Solar Salt

- High temperatures
- High energy density
- Low cost
- Stability, Longevity
- High 1st and 2nd Law Efficiency
- Simplicity
- Compatibility
- Rapid startup

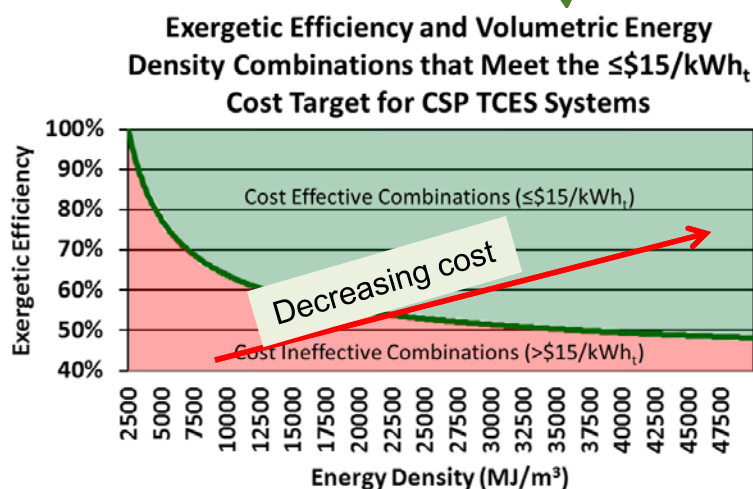
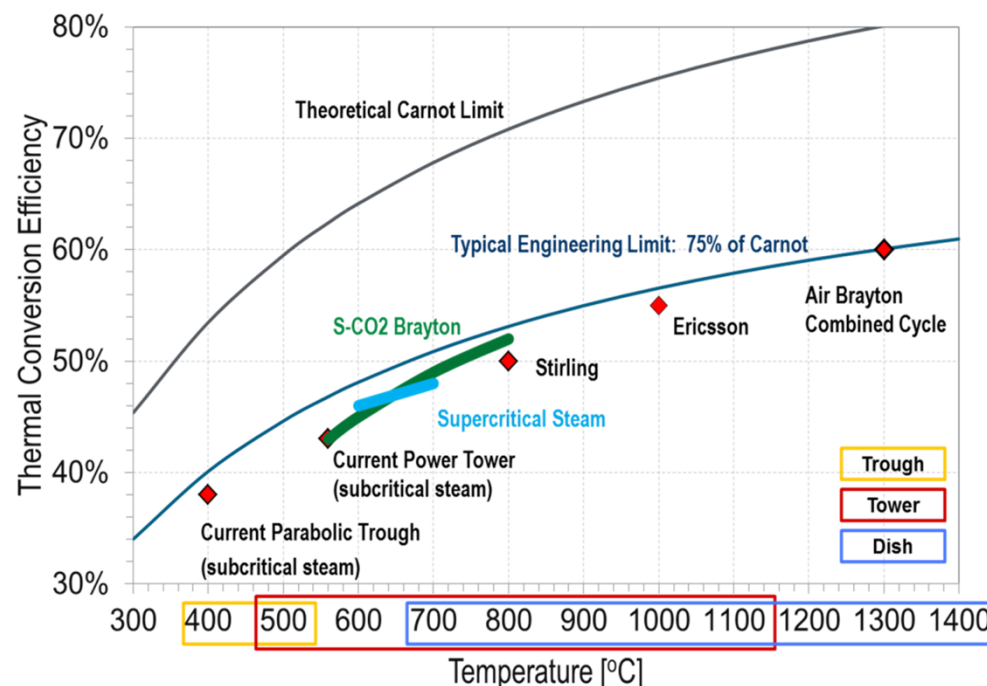

Solar Salt
 405 kJ/kg, $T < 650\text{ }^\circ\text{C}$, $\$30\text{ kWh}_{th}$

Goal
 1500 kJ/kg, $T > 1000\text{ }^\circ\text{C}$, $\$15\text{ kWh}_{th}$

Project Concept

1. New MIEC materials enable high temperature, high energy density storage

5. Systems and techno-economics to predict cost and performance and to guide development efforts

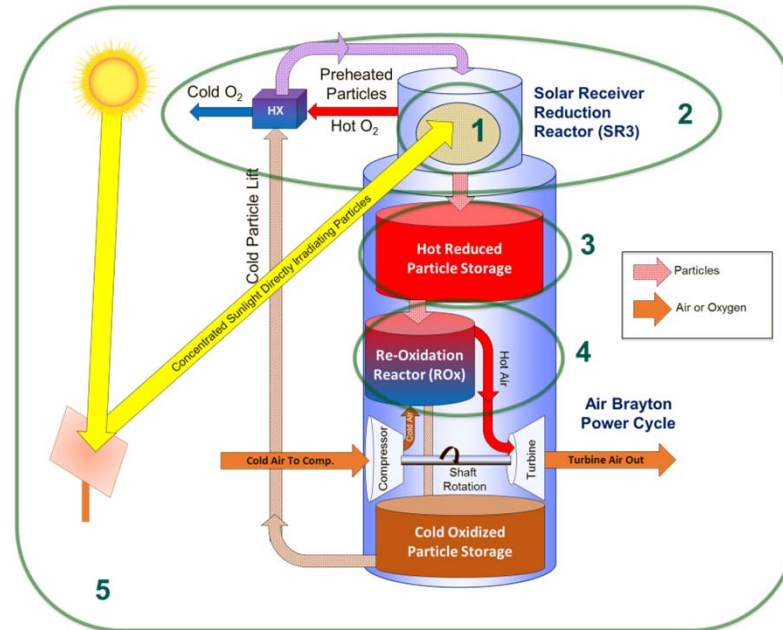

2. SR3: A particle receiver tailored to metal oxide reduction reactions

3. Hot Storage Bin: High temperatures ($T > 1000\text{ }^{\circ}\text{C}$) and an O_2 -free environment

4. ROx: Reoxidation reactor -- replaces the combustor in a power block. Compressed air acts as both reactant and heat transfer fluid. High $p\text{O}_2$ facilitates heat recovery at high temperatures. Open cycle -- no gas storage.

Phase 1: Develop & Characterize materials & TE models

Phase 2: Midscale Component Development and Demo

Phase 3: Larger scale test on-sun

Project Concept

1. New MIEC materials enable high temperature, high energy density storage

5. Systems and techno-economics to predict cost and performance and to guide development efforts

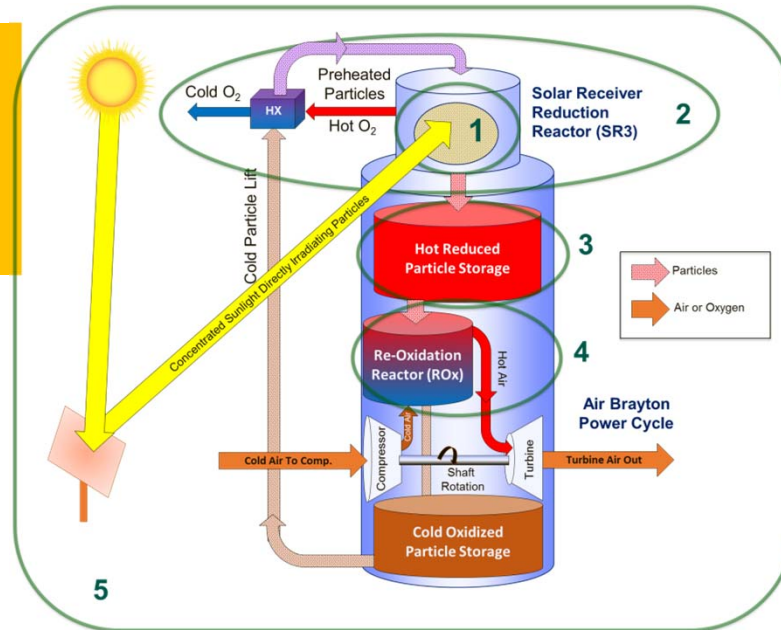

2. SR3: A particle receiver tailored to metal oxide reduction reactions

3. Hot Storage Bin: High temperatures ($T > 1000\text{ }^{\circ}\text{C}$) and an O_2 -free environment

4. ROx: Reoxidation reactor -- replaces the combustor in a power block. Compressed air acts as both reactant and heat transfer fluid. High pO_2 facilitates heat recovery at high temperatures. Open cycle -- no gas storage.

Phase 1: Develop & Characterize materials & TE models

Phase 2: Midscale Component Development and Demo

Phase 3: Larger scale test on-sun

TCES starting point mirrors TCWS

- Binary Oxides (Mn, Co, Fe) with distinct phase transitions.
- Issues include low temperature reaction kinetics (oxidation), poor utilization, sintering, cost, volatility, poor tunability, etc.

Characteristic reaction enthalpy (ΔH_{rxn}) and reaction temperature (T_0).

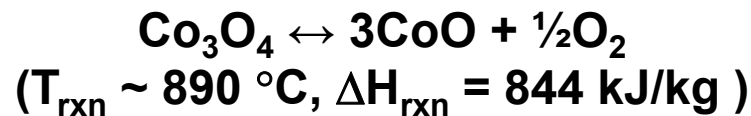
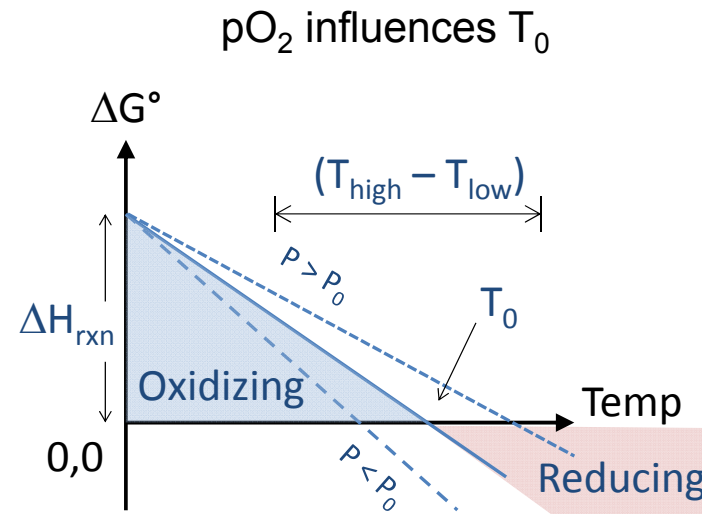
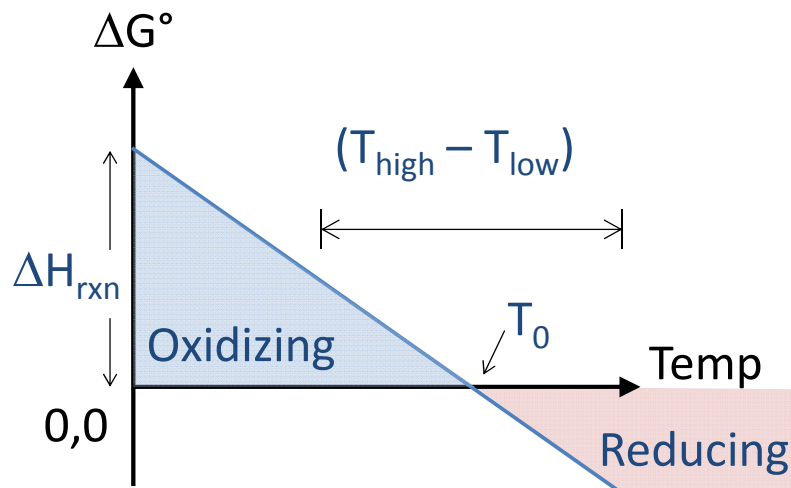

Mixed Ionic-Electronic Conductors

Mixed conductivity facilitates reaction kinetics, reaction extent, redox activity.

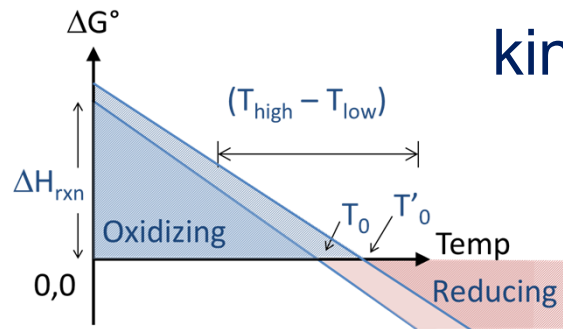

Perovskites (not the solar cell kind)

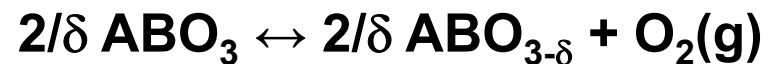

Continuum of oxidation states over variety of T and $p\text{O}_2$

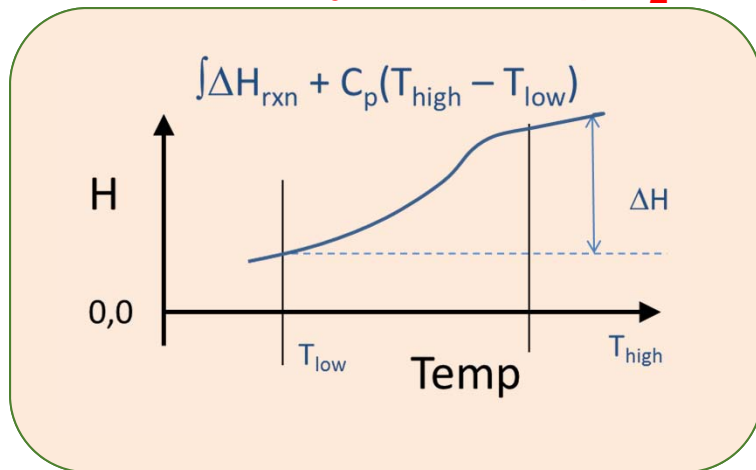

- Selective and reversible redox rxns
- Substitution to tune thermo (δ and T_0) ($\text{A}_x\text{A}_{1-x}'\text{B}_y\text{B}_{1-y}'\text{O}_3$)
- $\text{La}_{0.3}\text{Sr}_{0.7x}\text{Co}_{0.9}\text{Mn}_{0.1y}\text{O}_3 = \text{LSCM3791}$
- Higher temperature reduction implies greater ΔH , but generally smaller δ
- Oxygen nonstoichiometry without structure decomposition
- Robust and thermally stable

$$\Delta H_{total} = \frac{\partial}{2} \Delta H_{rxn} + \bar{C}_P (T_{high} - T_{low})$$

Binary Oxide vs. Perovskite (MIEC)

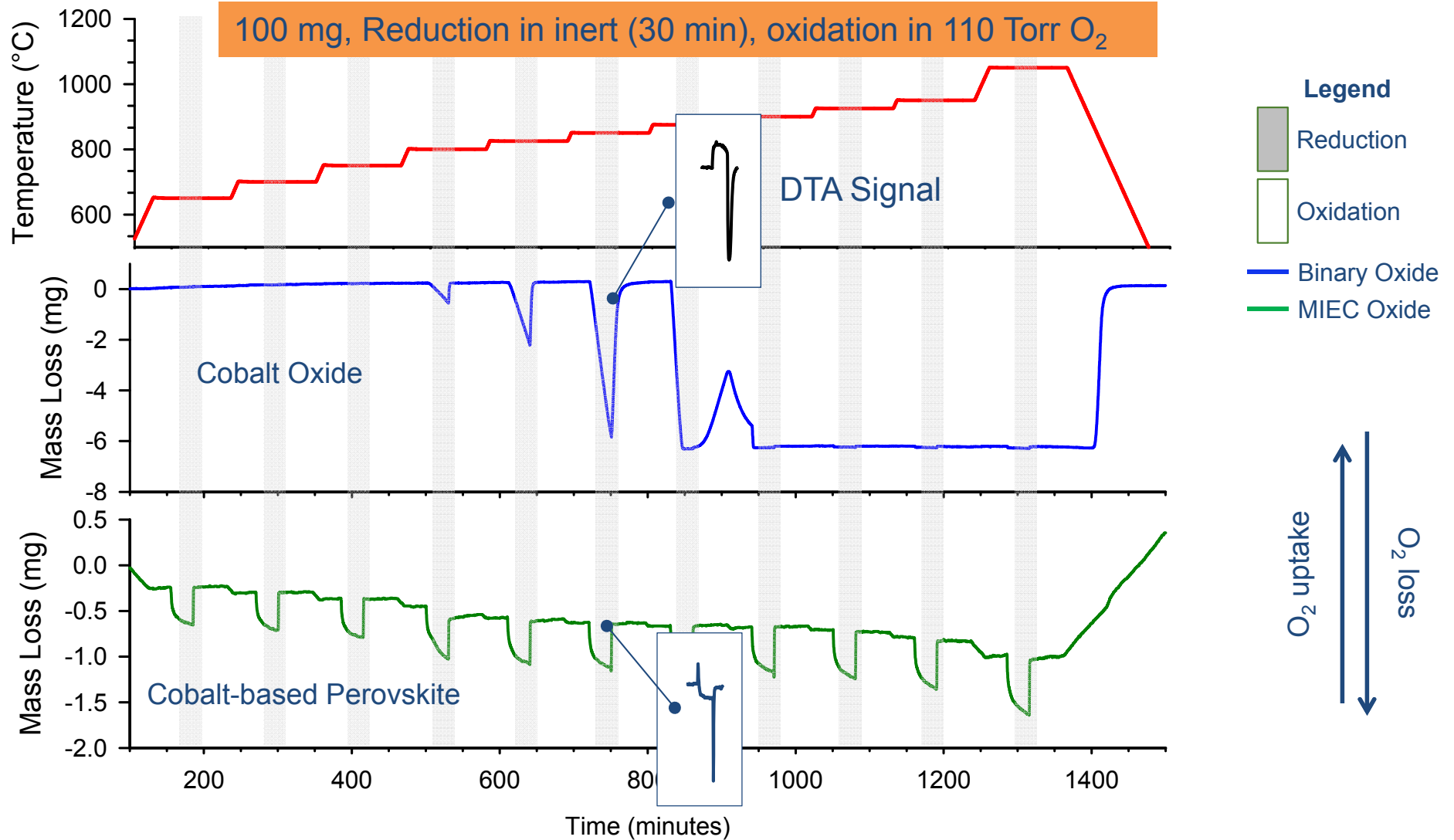

Binary Oxide vs. Perovskite (MIEC)

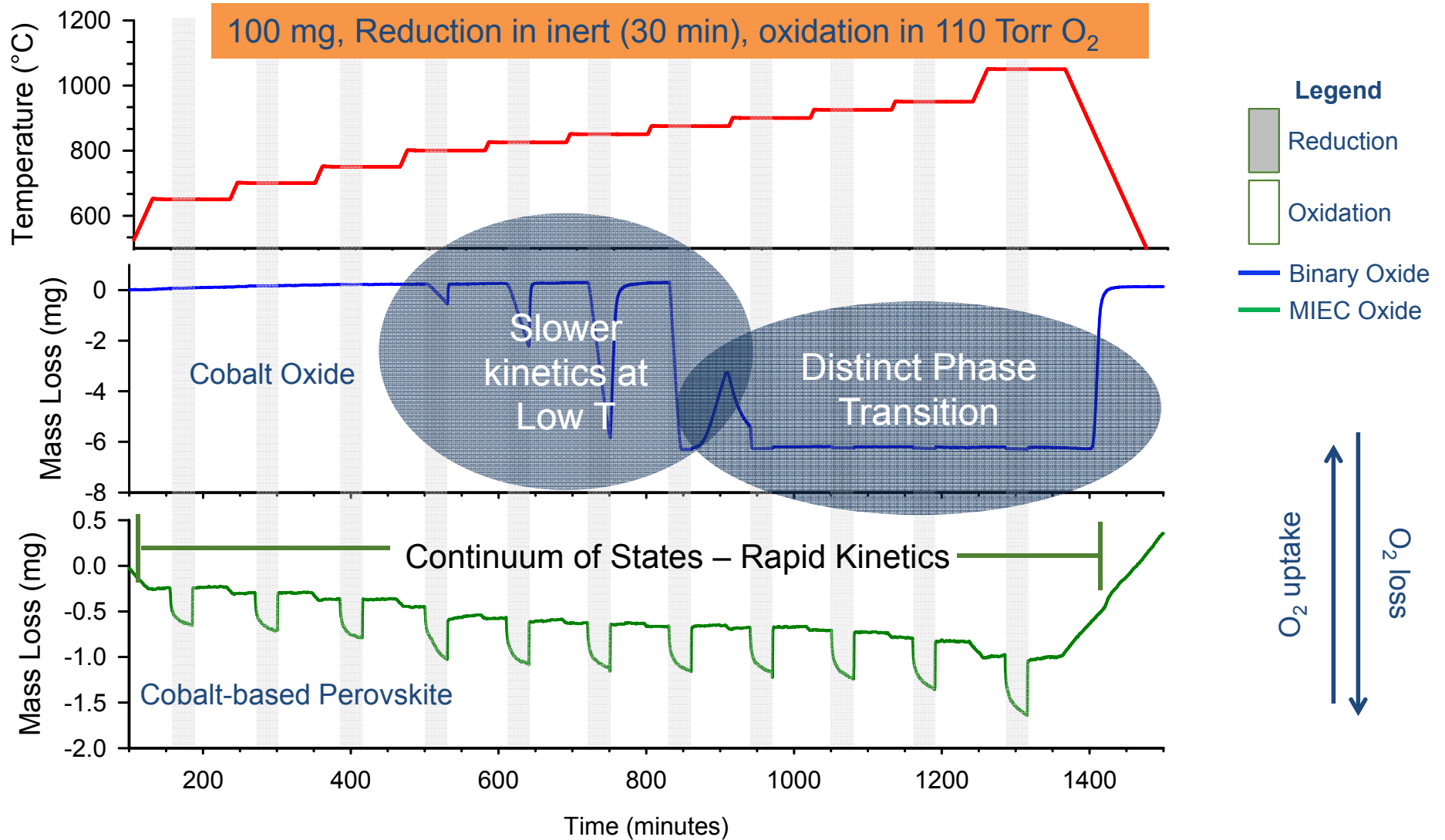

Binary Oxide vs. Perovskite (MIEC)

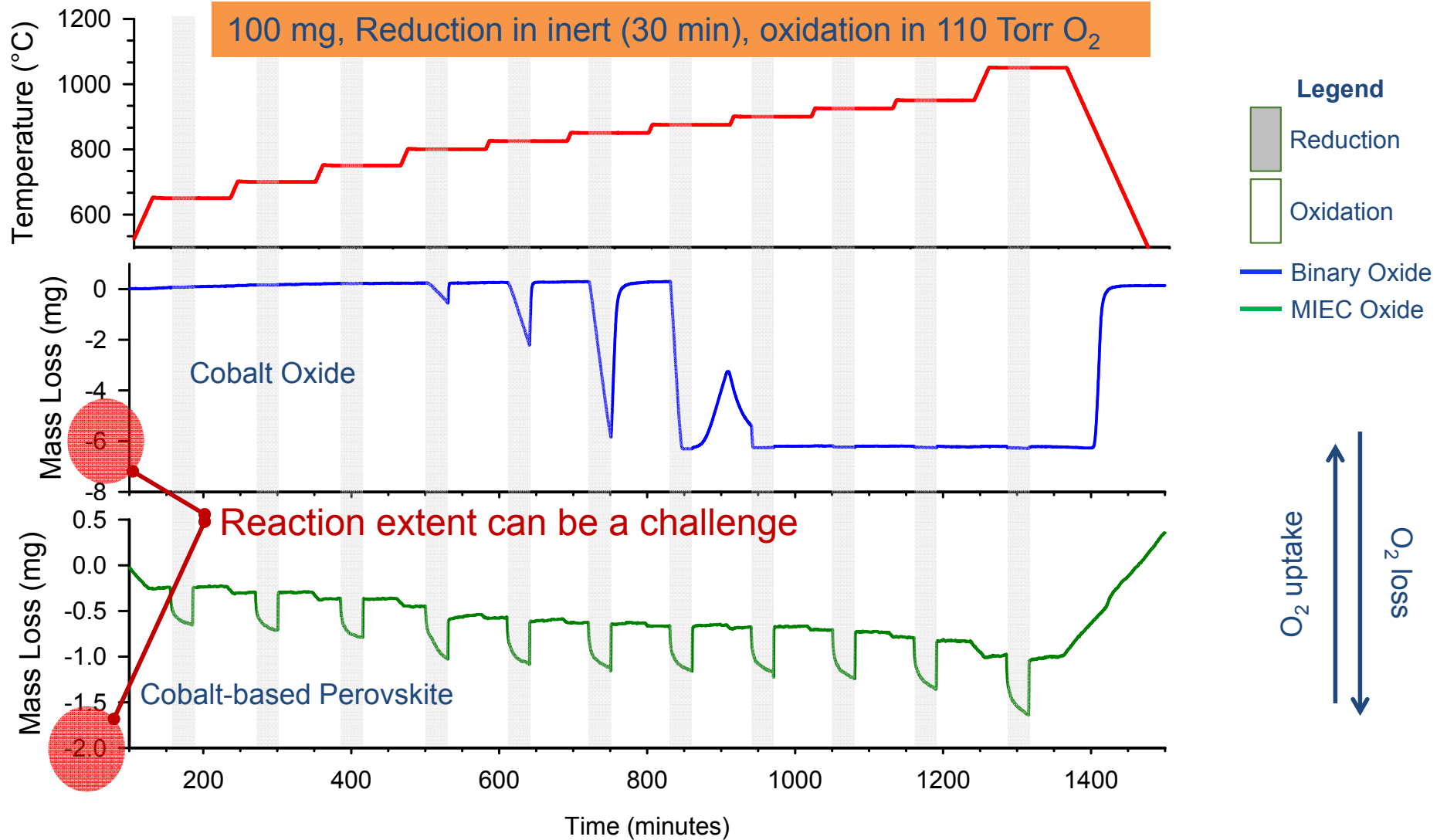

Materials: Reaction Enthalpy

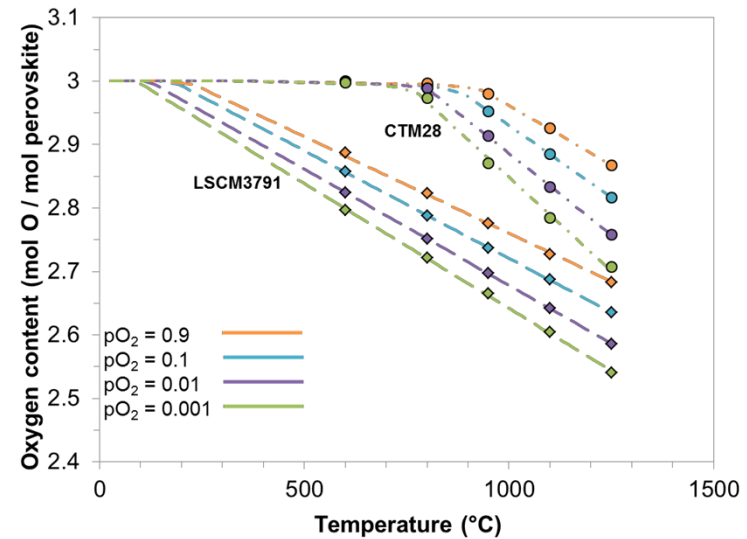
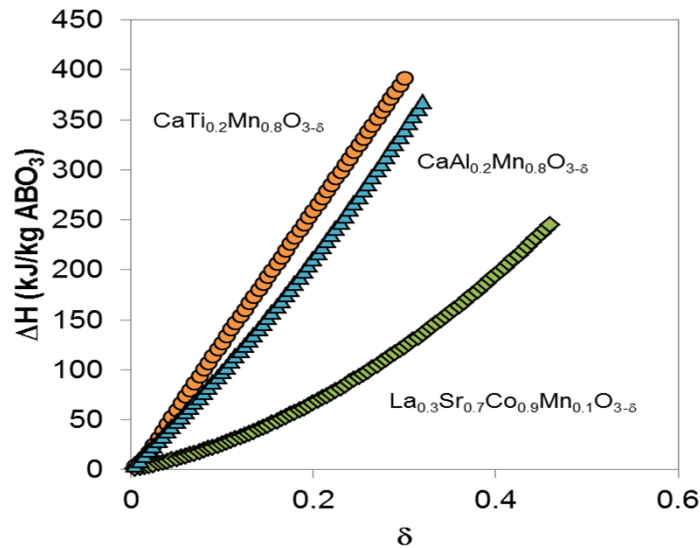

- First gen LSCM, LSCF, and related materials to identify baseline LSCM3891h
 - high redox capacity ($\delta = 0.46$) and reasonable ΔH_{rxn} (242 kg/kJ)
- Second generation: Low-cost earth-abundant compositions CXM (X = Ti, Al)
 - Lower δ compensated by higher T_{red} \rightarrow Stronger M-O bonds and storage of higher-quality heat
 - higher specific heat per unit mass

Materials: Total Storage Capacity

$$\Delta H_{\text{tot}} = \Delta H_{\text{rxn}} + C_p \Delta T$$

Chemical + Sensible Energy Storage

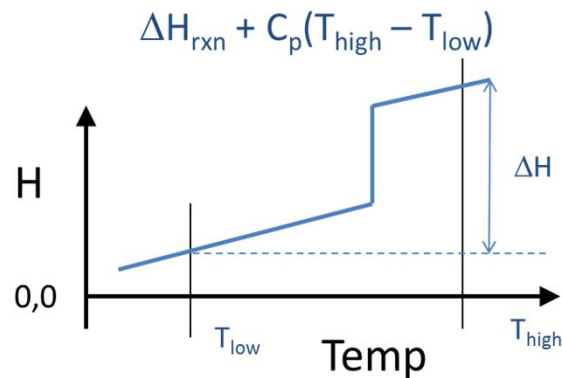

Measured heat capacity as a function of temperature

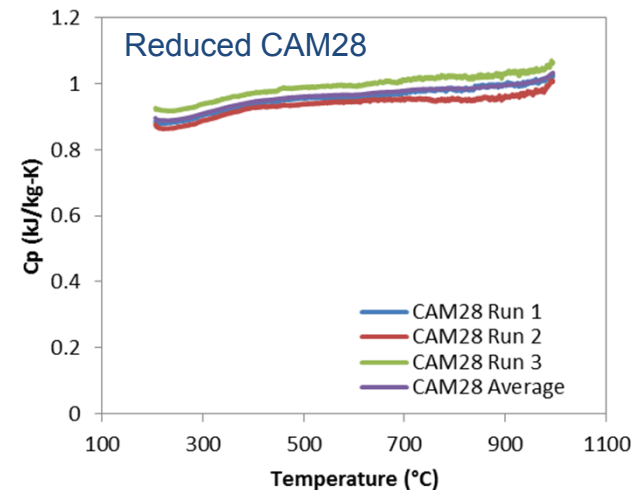

Candidate material	Mol weight (g/mol)	$T_{\text{red Onset}}$ (°C)	Max δ	ΔH_{rxn} (kJ/kg) (at δ_{max})	C_p (kJ/kg-K)	ΔH_{tot} (kJ/kg)
LSCM379 1	209.5	343	0.461	242	*0.595	837
CTM28	141.6	901	0.293	393	*0.881	1274
CAM28	135.8	759	0.322	371	*0.910	1281

*Estimated Values: $C_p = 3R \cdot N$ (J/mol-K) = 15R, $T_{\text{high}} = 1200$ °C, $T_{\text{low}} = 200$ °C

Materials: Cycle-to-Cycle Stability

Extended thermal redox cycling in TGA

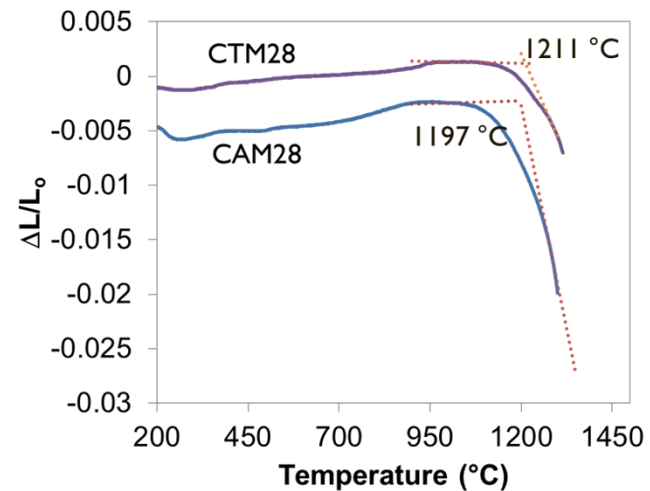
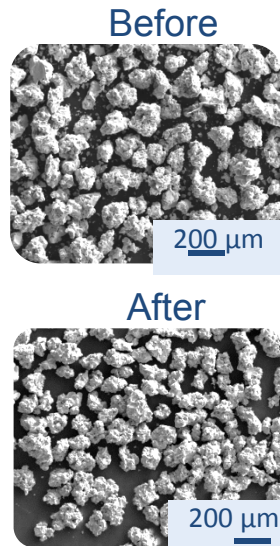
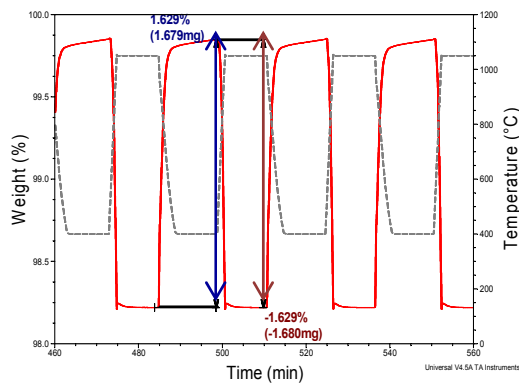
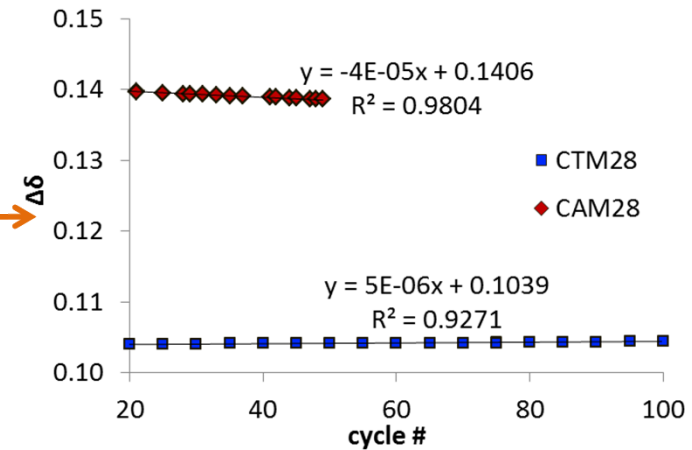
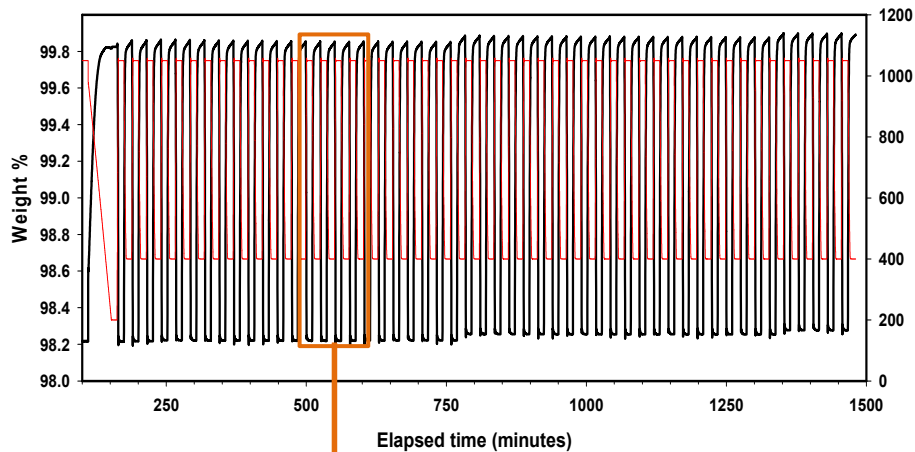

SEM of cycled particles Sintering (dilatometry) of compressed pellets (worst case)

Rapid Kinetics and Favorable Costs

“Upflow reactor” coupled to high flux solar simulator (> 50 K/s) measures reduction kinetics

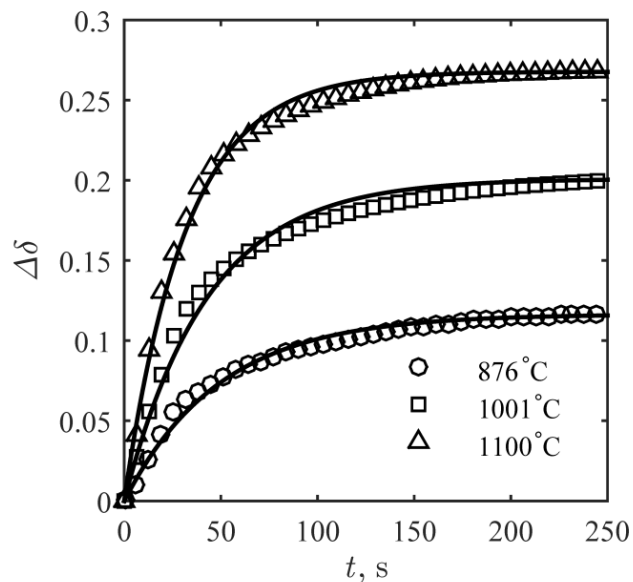

CAM28

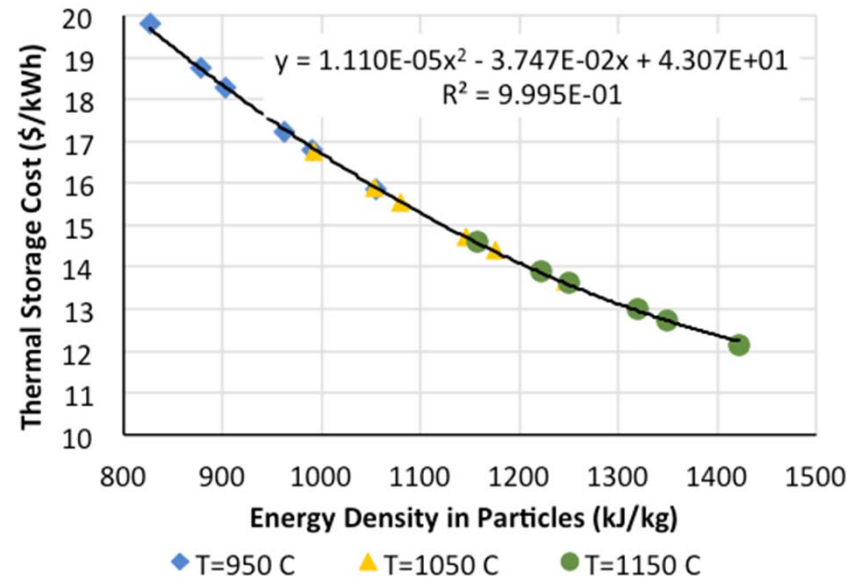

- Particle inventory sensitive to T_{air} in, SR3 operation, ROx operation, etc.
 - \$8.50/kWh_{th} (CAM28 reduced at 1050 °C and 200 Pa pO₂ ($\delta=0.203$), T_{part} out = 388 °C)
- Storage volume scales with amount of particles, cost scales more slowly
 - Estimated at \$4.60/kWh_{th}

Results of collaborations with P. Loutzenheiser (GIT), and E. Stechel, N. Johnson (ASU)

Though I focused on Materials - Modeling, Building, Testing Reactors

SR3 – Georgia Tech

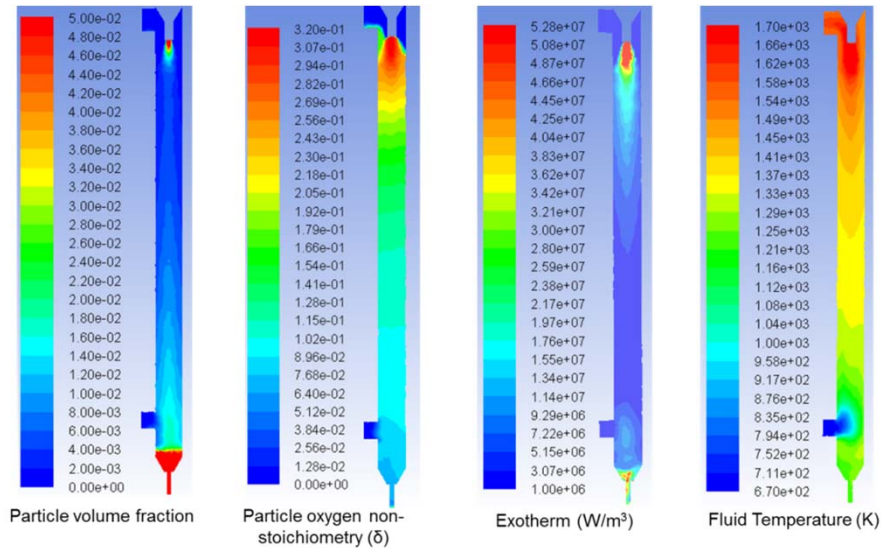
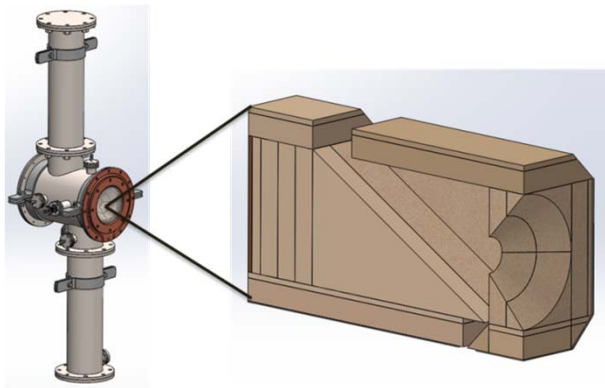

Spatial Temperature

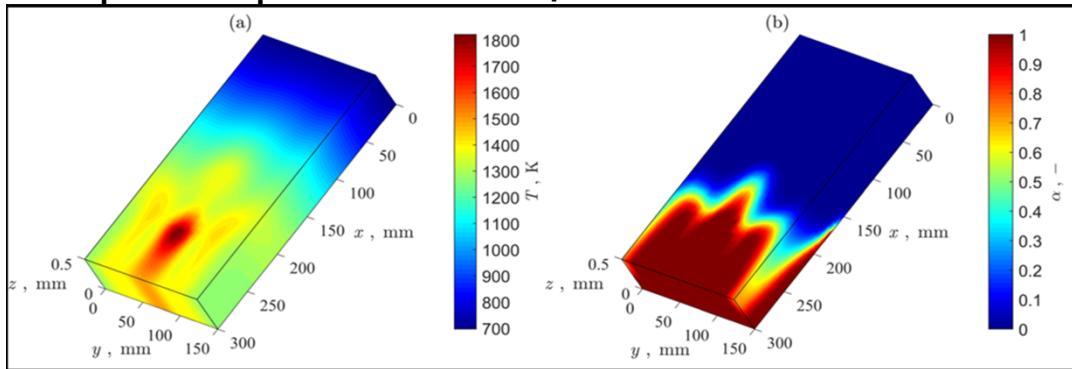

Spatial conversion

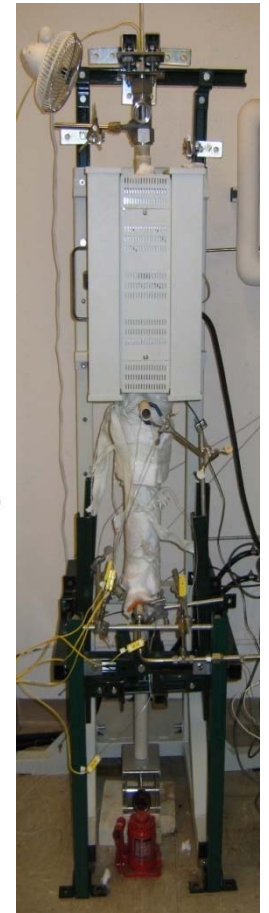
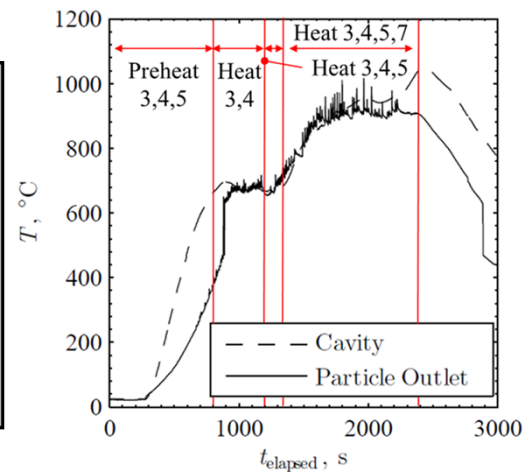

ROX - SNL

Take-home points

Producing solar fuels and storing heat via thermochemical processes has the potential for transformational impact on our energy future.

- ✓ For any approach to Solar Fuels (or CO₂ utilization more generally) - Efficiency is key for cost and scalability – 10% solar to fuel minimum.
- ✓ For TCES low cost, high energy density, high temperature are necessary
- Materials, Reactors, and Systems all areas of opportunity and need.
 - All impact important metrics, all relatively immature for this technology.
 - A comprehensive and coordinated cross-discipline effort is preferred.
 - Small global community has made significant advances in recent years.

We have barely begun to explore the possibilities

Challenging Demands for Materials

TCES	Attribute	Solar Fuels
✓	Simple, Repeatable Chemistry (No side reactions, No intermediate processing)	✓
✓	Thermodynamics - matched to application	✓
✓	Long Term Stability – chemical and physical (years – 1000s if not millions of cycles)	✓
✓	Efficient volumetric/mass usage (utilization/energy density per cycle)	✓
✓	Rapid Kinetics	✓
✓	High Melting /Low Volatility/Sinter Resistant	✓
✓	Amenable to integration with receivers	✓
✓	Low Cost	✓

Pathways: Modification, Hybridization, Structuring, Invention

Cast Of Characters (a snapshot)



S2P: Principal Investigator – James E. Miller
Project Managers - Ellen B. Stechel and Tony Martino

Systems

- Terry Johnson, Chad Staiger, Christos Maravelias (U-WI), Carlos Henao (student,) Jiyong Kim (PD), Daniel Dedrick

Reactor

- Solar Reactor - Rich Diver, Tim Moss, Scott Korey, Nathan Siegel
- Reactive Structures - Nathan Siegel, Terry Garino, Nelson Bell, Rich Diver, Brian Ehrhart
- Detailed Reactor Models - Roy Hogan, Ken Chen, Spencer Grange, Siri Khalsa, Darryl James (TTU), Luke Mayer (student)

Materials

- Reactive Materials Characterization & Development - Andrea Ambrosini, Eric Coker, Mark Rodriguez, Lindsey Evans, Stephanie Carroll, Tony Ohlhausen, William Chueh
- Bulk Transport & Surface Reactions - Gary Kellogg, Ivan Ermanoski, Taisuke Ohta, Randy Creighton
- Thermodynamics & Reaction Kinetics - Mark Allendorf, Tony McDaniel, Chris Wolverton (Northwestern University), Bryce Meredig (student), Heine Hansen (PD), Asegun Henry, Al Weimer (CU), Jonathan Scheffe (student)

The PROMOTES Team



Sandia National Labs

Andrea Ambrosini
Sean M. Babiniec
Eric N. Coker
Cliff K. Ho
Ken M. Armijo
James E. Miller



**Sandia
National
Laboratories**

Arizona State University

Ellen B. Stechel
Nathan G. Johnson



Georgia Tech

Peter G. Loutzenhiser
Sheldon M. Jeter



**Georgia Institute
of Technology**

King Saud University

Hany Al-Ansari



Powered by

SunShot

U.S. Department of Energy

PowerEnergy2016-59660

Thank You.

