

High Speed Video(HSV) 2D DIC Tester to Perform Turn-Key High-Speed Video Acquisition and Analysis of StrongLink Units

By Scott Walkington

With Special Thanks To: Alvaro Cruz-Cabrera, John Wagner, Miguel Palaviccini and Phil Reu

Outline

- Production Environment
- Problems with Commercial-of-the-Shelf Software(COTS)- PCC and VIC 2D
- Hardware for HSV Tester
- Precursors to the HSV Tester
- Walk through Test Sequence
 - Initialize
 - Capture Video
 - Registration
 - ASC Analysis
 - DIC Analysis
 - Curve Generation
 - Parameter Extraction
 - Limits Checking
- Conclusion

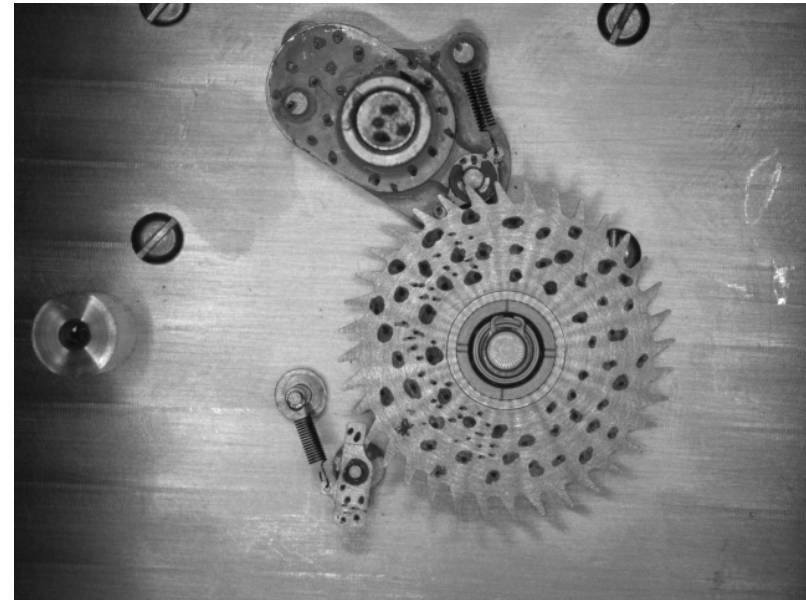

Different Environment- Production

- Sandia National Laboratories- R&D Laboratory
 - Not real production environment
 - Software Developers are the users of the software
- Production Factory
 - Speed
 - Repeatability
 - Production line- Deadlines
 - Reliability, Maintainability, and Supportability of the Systems



Complexity of Phantom(PCC) HSV Software

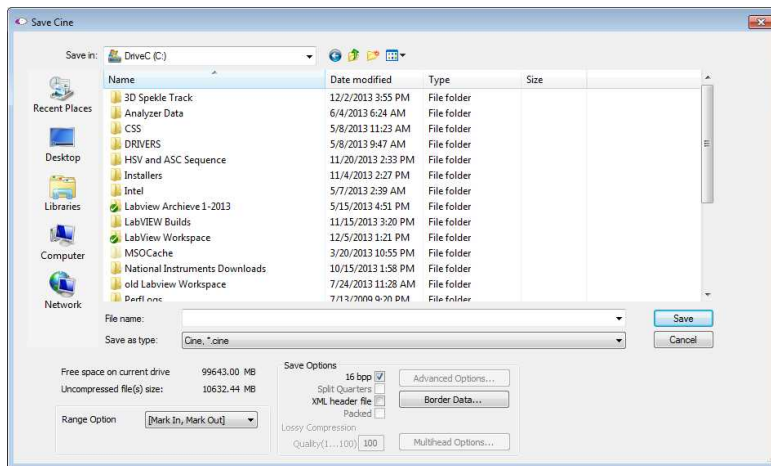
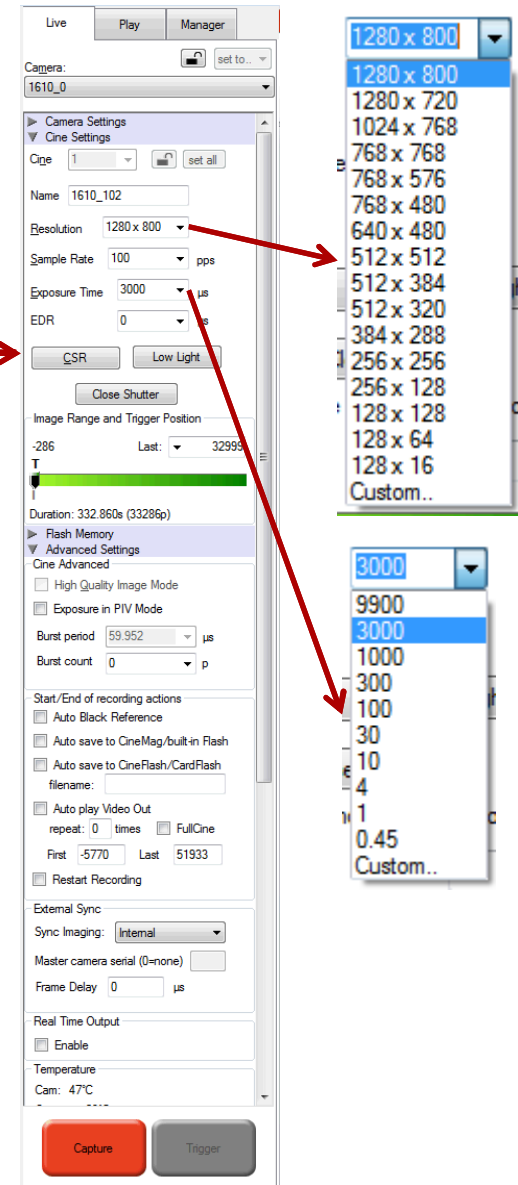
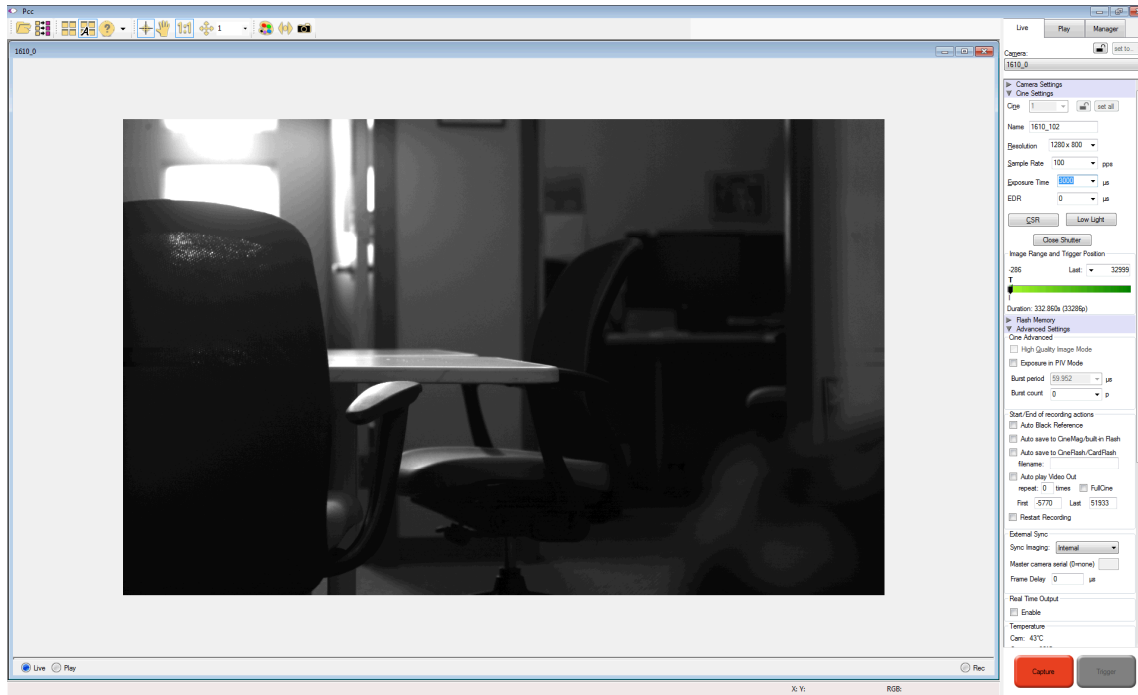

To much control/
complexity for a
standard user!
Easy to make
a mistake!

Disadvantages

- Long time to track a full run of a unit (about 8 hours)
- No easy way to save ROI
- Must convert .cine to .tiff
- Manually Save Tracked data to file
- No Batch Mode!

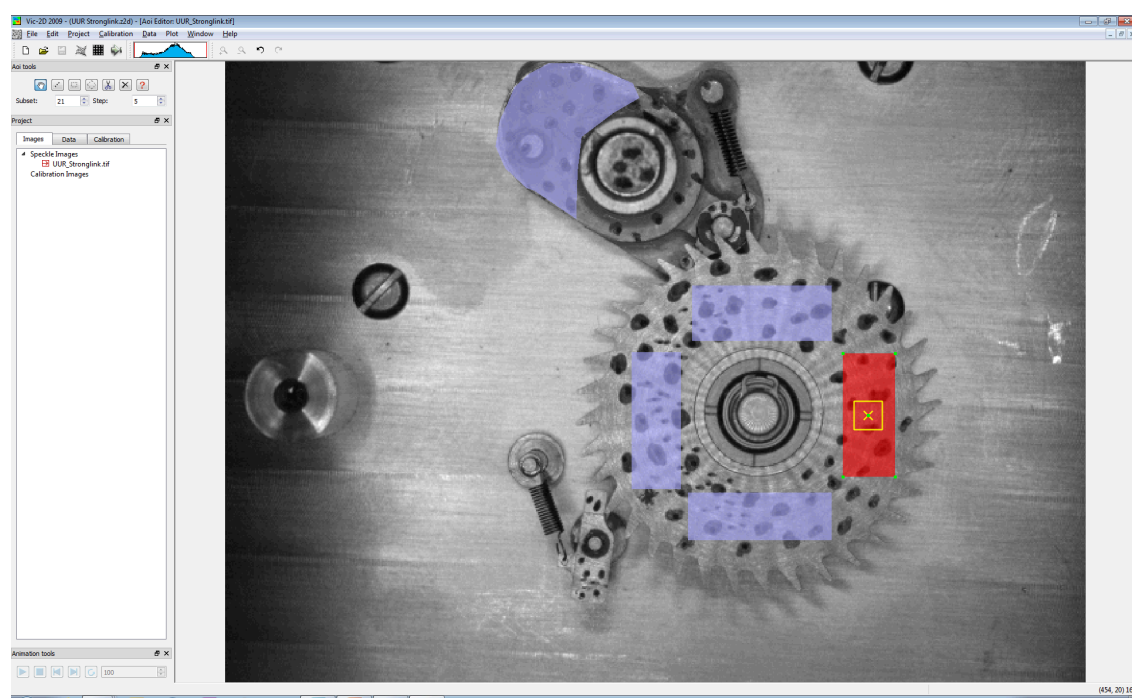

Camera and Light Dome Mount + Fixture.

ITEM NO.	PART NUMBER	DESCRIPTION	QTY.
1	2020 X 40	All Memeber are 40"	2
2	2020 X 30	All Memeber are 30"	1
3	8020-4138		14
4	8020-6424		3
5	8020-6850		6
6	8020-2753		1
7	2020 X 8	All Memeber are 8"	2
8	8020-4125		2
10	8020-2568	All Memeber are 18"	2
11	1/4-20 Screws	Lots	???

DETAIL A
SCALE 1 : 4

UNLESS OTHERWISE SPECIFIED:	NAME	DATE
DIMENSIONS ARE IN INCHES	DRAWN	SW
TOLERANCES:	CHECKED	12/3/2012
FRONTALS:	ENG APPR.	
ANGULARS: MACH. ± BEND ±	MFG APPR.	
TWO PLACE DECIMAL ±		
THREE PLACE DECIMAL ±		

Sandia National Laboratories

PROPERTY AND CONFIDENTIAL
THE INFORMATION CONTAINED IN THIS DRAWING IS THE SOLE PROPERTY OF SANDIA NATIONAL LABORATORIES. ANY REPRODUCTION IN PART OR AS A WHOLE WITHOUT THE WRITTEN PERMISSION OF SANDIA NATIONAL LABORATORIES IS PROHIBITED.

INTERPRET GEOMETRIC TOLERANCING PER: G.A.

Drawn By: Scott Walkington
Drawn For: Alvaro Augusto Cruz-Cabrera

MATERIAL: Aluminum
FINISH: Anodized
DO NOT SCALE DRAWING

SIZE: A
Camera and Light Dome Mount
REV: 1
SHEET 1 OF 2

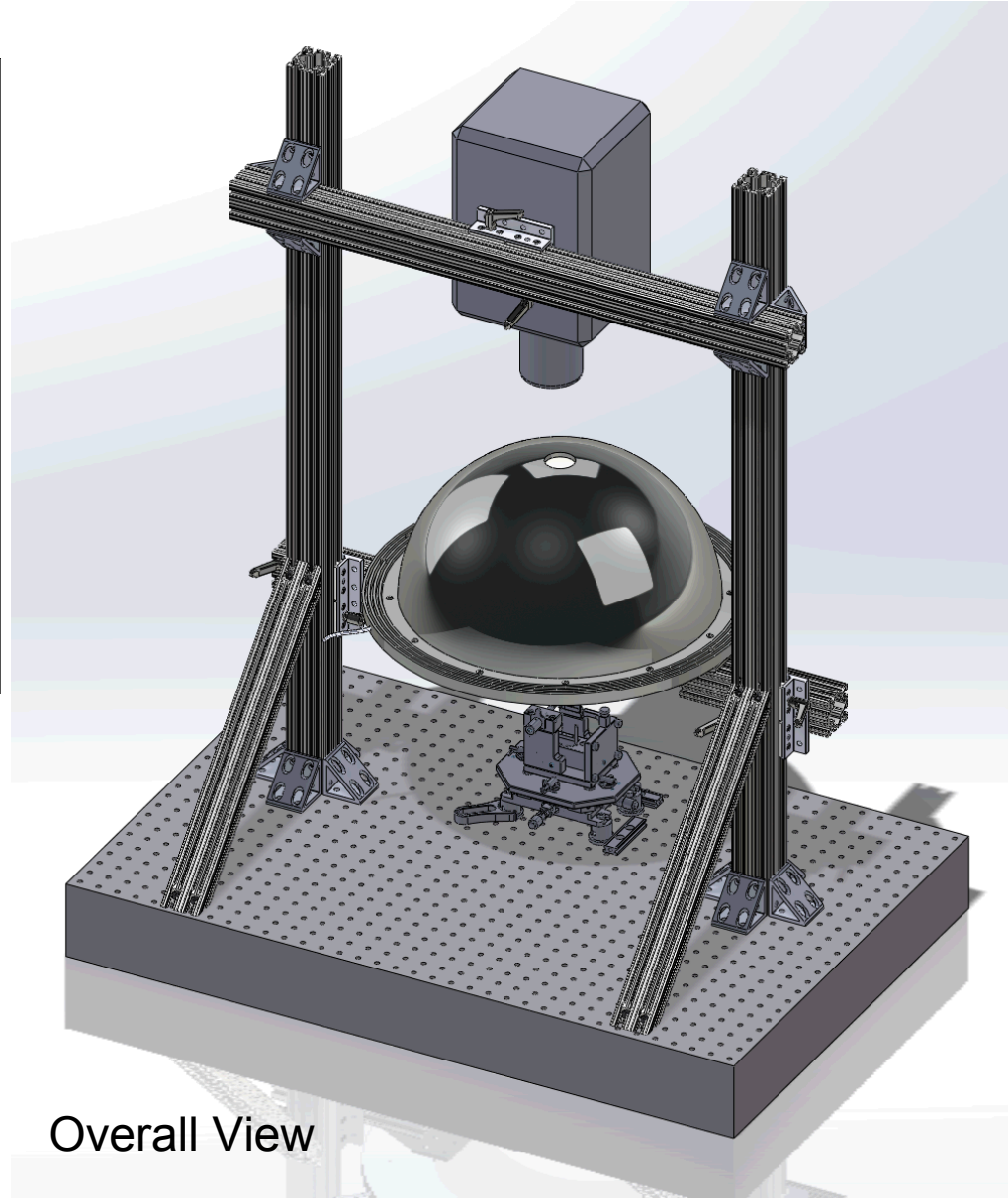

Overall View

Camera and Light Dome Mount + Fixture.

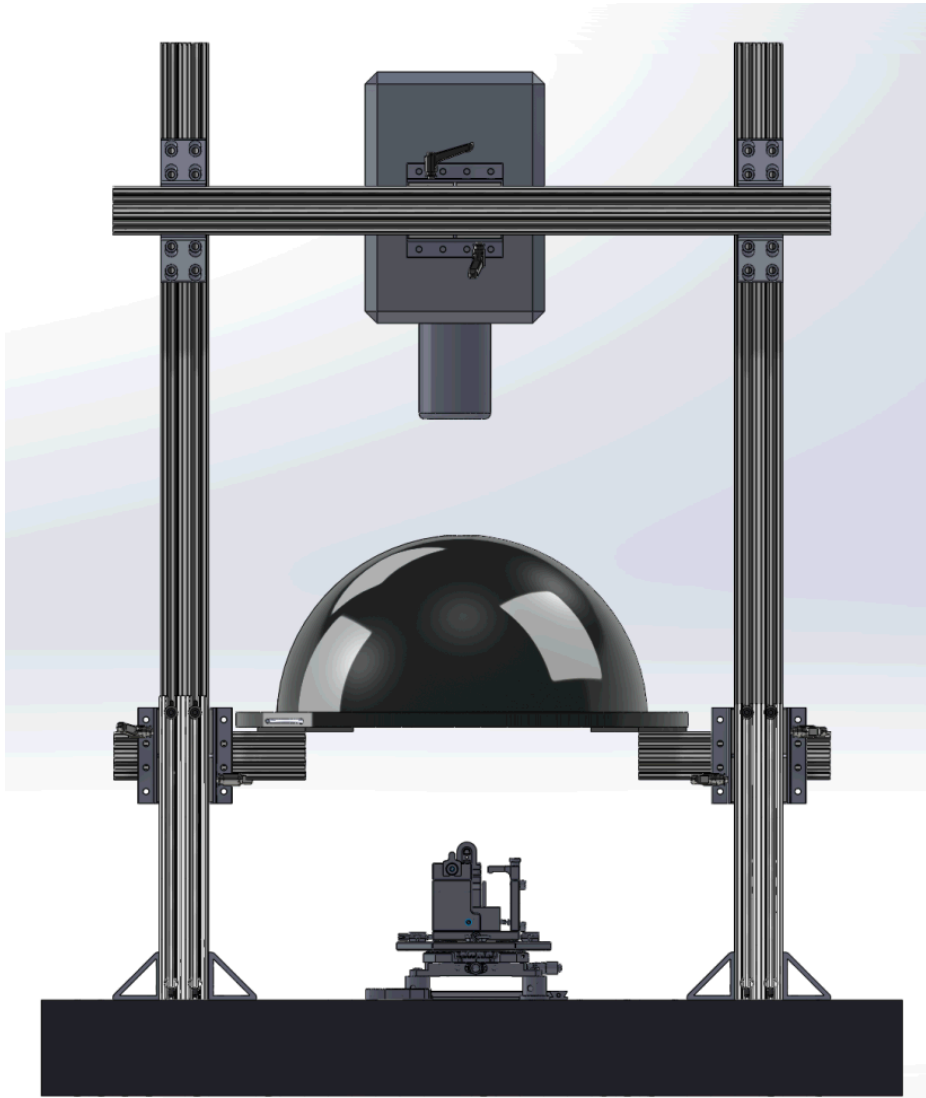

Front View

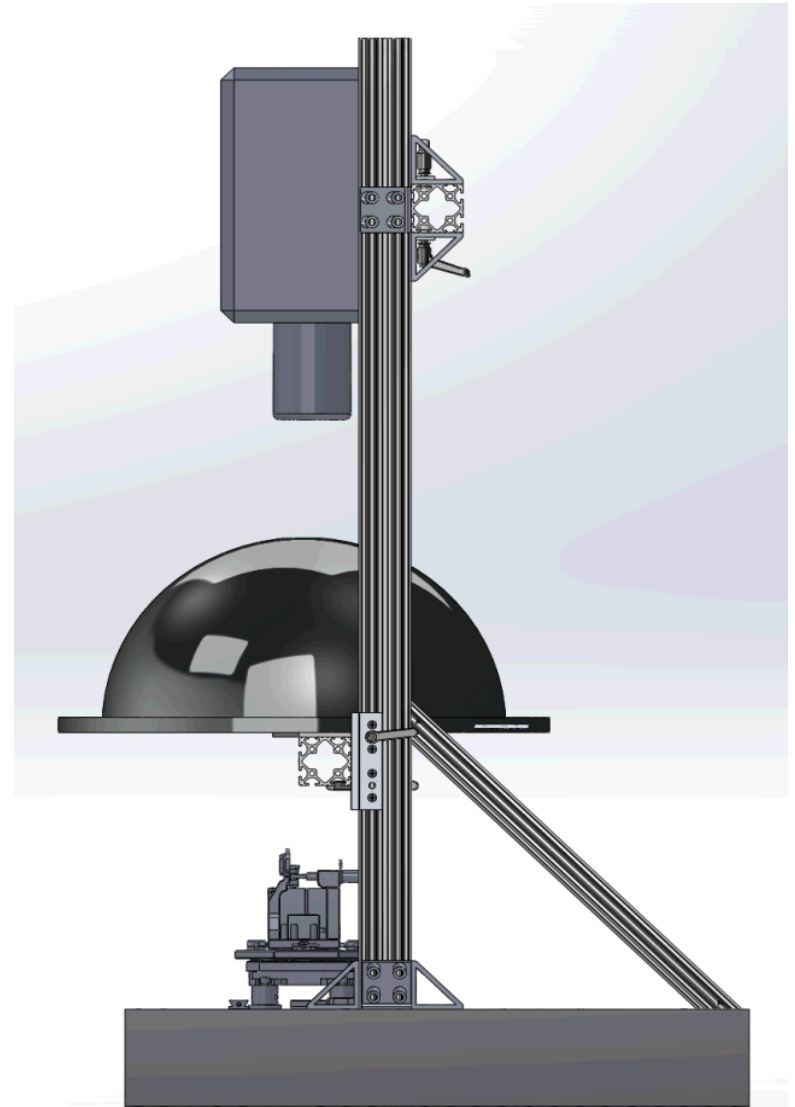

Side View

Speckle Track Software

Speckle Track KC.vi

File System Help

Open Movie (*.cine) Remove Subset Open ROI from Binary Run Analysis Abort Track

Set Subset Save ROI to Binary

subset_size: 35

CurrentImage: 5040

Current Date/Time: 11:53:55.0 12/10/2013

Window Size: 400

Analyzing...

Video Selected: 20hz_holdPawl.cine



Area 05-u
Area 05-v
Area 06-u
Area 06-v

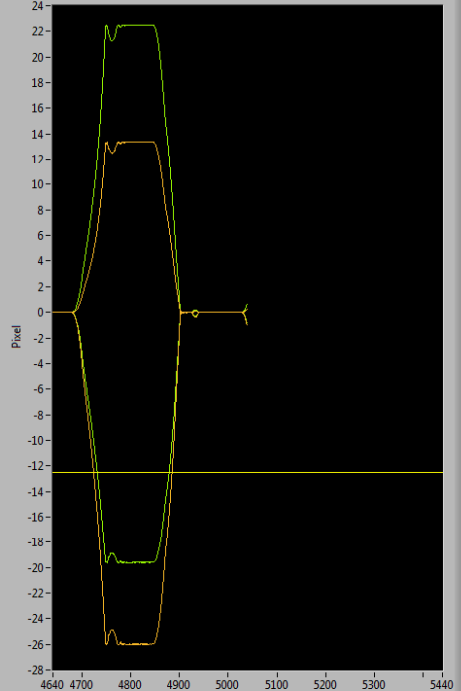

Pixel

4640 4700 4800 4900 5000 5100 5200 5300 5440

Area 05-u
Area 05-v
Area 06-u
Area 06-v

Frame Number	Area 01	Area 02	Area 03	Area 04	Area 05	Area 06
X						
Y						
du/dx						
dv/dx (Rotation)						
du/dy (Rotation)						
dv/dy						
sigma						
x_c						
y_c						
u_c						
v_c						
f_c						

Batch Directory

Select Batch Directory Select Files / Folders Run Batch

Directories

640x480 1.10X 8-bit image 6 (0,0)

Two Different Testers

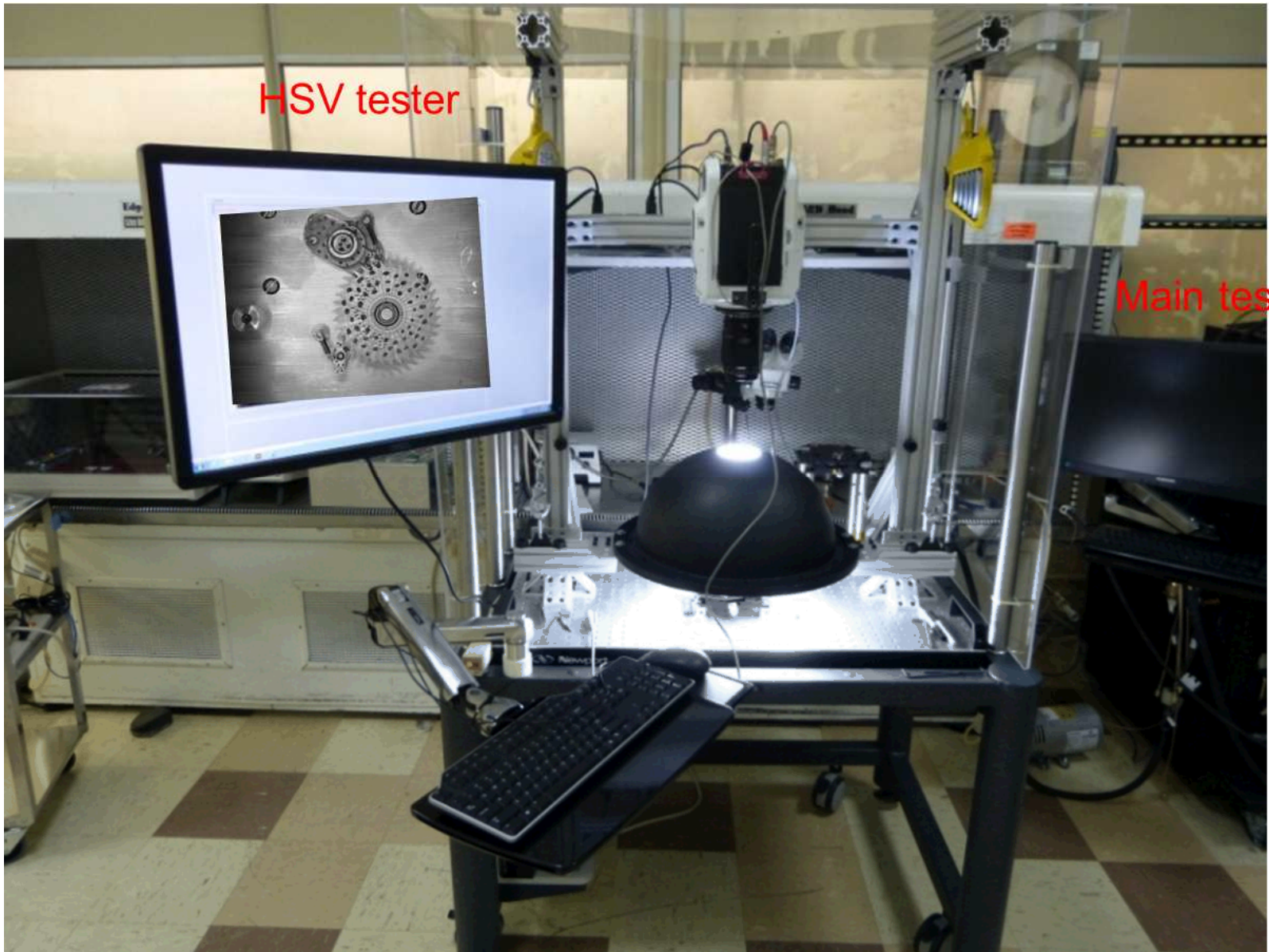

NI TestStand - Sequencer

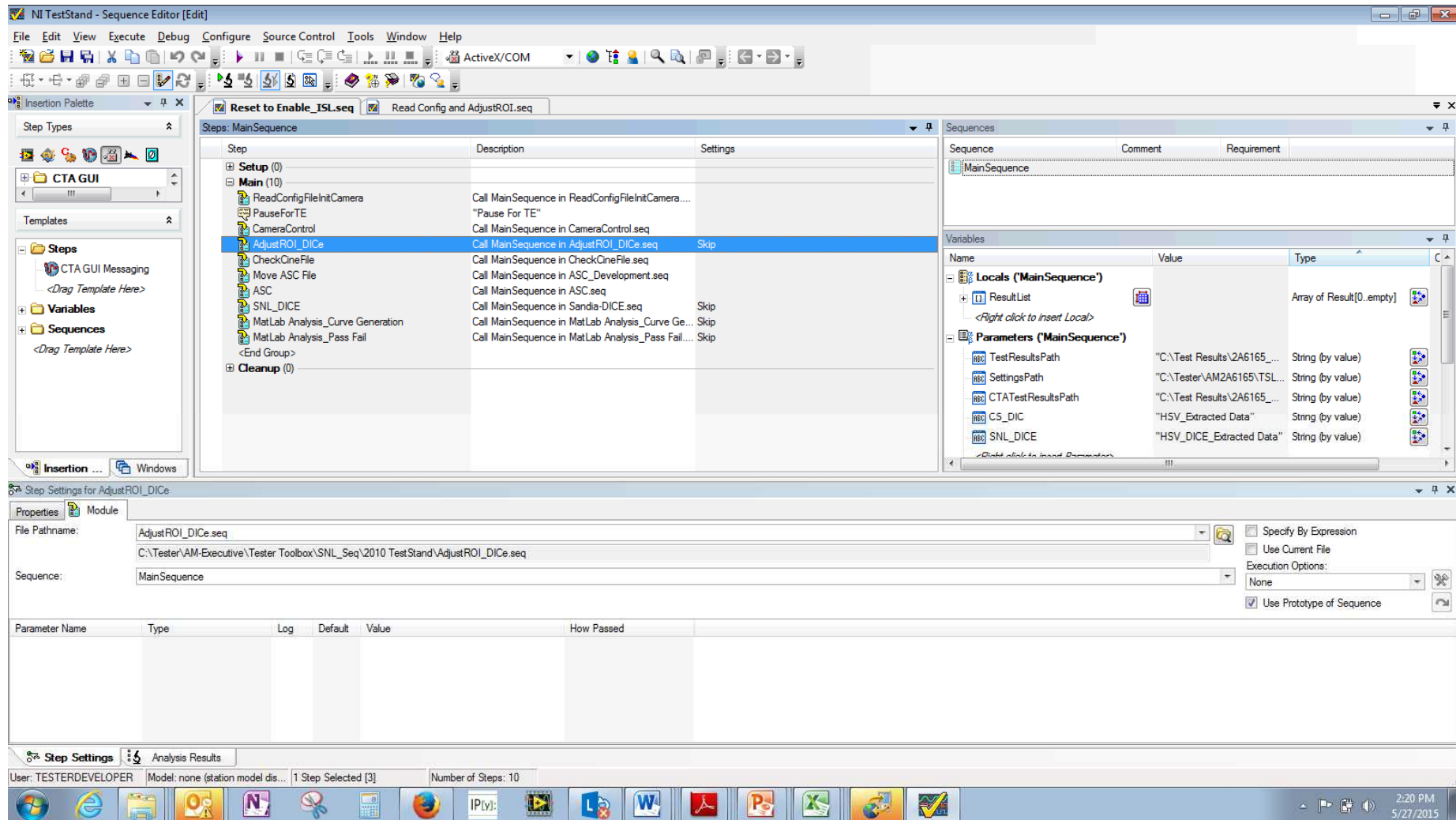

The screenshot displays the NI TestStand - Sequence Editor interface. The main window shows a sequence tree on the left with 'MainSequence' expanded to show steps like 'Setup (0)', 'Main (10)', and 'Cleanup (0)'. The 'Main (10)' step is further expanded to show sub-steps such as 'ReadConfigFileInitCamera', 'PauseForTE', 'CameraControl', 'AdjustROI_DICe', 'CheckCineFile', 'Move ASC File', 'ASC', 'SNL_DICE', 'MatLab_Analysis_Curve Generation', and 'MatLab_Analysis_Pass Fail'. The 'AdjustROI_DICe' step is selected, and its properties are shown in the 'Step Settings for AdjustROI_DICe' window at the bottom. This window includes fields for 'File Pathname' (C:\Tester\AM-Executive\Tester_Toolbox\SNL_Seq\2010 Test Stand\AdjustROI_DICe.seq) and 'Sequence' (MainSequence). It also has checkboxes for 'Specify By Expression', 'Use Current File', 'Execution Options' (set to None), and 'Use Prototype of Sequence' (checked). A table below the properties window is empty, with columns for 'Parameter Name', 'Type', 'Log', 'Default', 'Value', and 'How Passed'. The bottom status bar shows 'User: TESTERDEVELOPER', 'Model: none (station model dis...)', '1 Step Selected [3]', and 'Number of Steps: 10'. The Windows taskbar at the bottom shows the time as 2:20 PM on 5/27/2015.

Step	Description	Settings
Setup (0)		
Main (10)		
ReadConfigFileInitCamera	Call MainSequence in ReadConfigFileInitCamera....	
PauseForTE	"Pause For TE"	
CameraControl	Call MainSequence in CameraControl.seq	
AdjustROI_DICe	Call MainSequence in AdjustROI_DICe.seq	Skip
CheckCineFile	Call MainSequence in CheckCineFile.seq	
Move ASC File	Call MainSequence in ASC_Development.seq	
ASC	Call MainSequence in ASC.seq	
SNL_DICE	Call MainSequence in Sandia-DICE.seq	Skip
MatLab_Analysis_Curve Generation	Call MainSequence in MatLab_Analysis_Curve Ge...	Skip
MatLab_Analysis_Pass Fail	Call MainSequence in MatLab_Analysis_Pass Fail...	Skip
<End Group>		
Cleanup (0)		

Name	Value	Type
Locals ('MainSequence')		
ResultList		Array of Result[0..empty]
Parameters ('MainSequence')		
TestResultsPath	"C:\Test Results\2A6165_...."	String (by value)
SettingsPath	"C:\Tester\AM2A6165\TSL...."	String (by value)
CTATestResultsPath	"C:\Test Results\2A6165_...."	String (by value)
CS_DIC	"HSV_Extracted Data"	String (by value)
SNL_DICE	"HSV_DICE_Extracted Data"	String (by value)

Parameter Name	Type	Log	Default	Value	How Passed
----------------	------	-----	---------	-------	------------

Certified Tester Architecture(CTA)

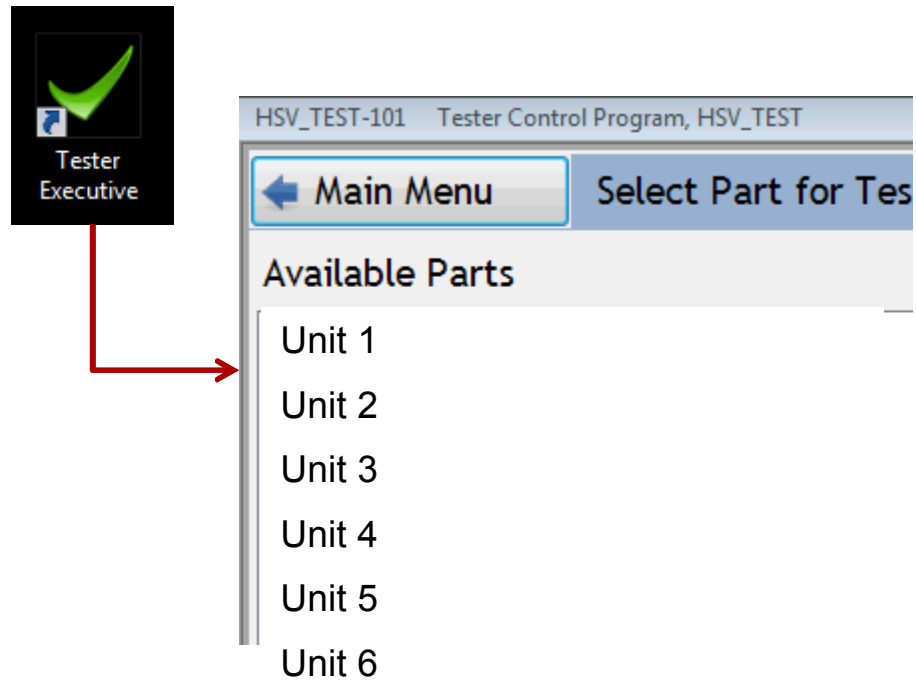

Initializing/Setup

```
SOSRE.ini - Notepad
File Edit Format View Help
[[Test Description]
Test Description = SOSRE

[Paths]
DataFolder = C:\Test Results
Cine =
DIC Results Folder =
CurveGenerationCode = C:\Tester\AM-Executive\Tester Toolbox\SNL_Se
CurveGenerationCode Settings =
ASC Code = C:\Tester\AM-Executive\Tester Toolbox\SNL_Seq\MatLab\AS
ASC Code Settings = C:\Tester\AM-Executive\Tester Toolbox\SNL_Seq\
Temp ASC Data Folder = \\LT6035496\ASCFileshare\FOR HSV
TOMS Data Path =
PassFail Code = C:\Tester\AM-Executive\Tester Toolbox\SNL_Seq\MatL
PassFail Code Settings =
Feature Recognition Code = C:\Tester\AM-Executive\Tester Toolbox\S
The Closer Code = C:\Tester\AM-Executive\Tester Toolbox\SNL_Seq\Ma
Phantom STG File = C:\ProgramData\Phantom\744\14020.stg
PhantomPCOND11 = C:\Tester\AM-Executive\Tester Toolbox\SNL_Seq\Pha
PhantomPFILED11 = C:\Tester\AM-Executive\Tester Toolbox\SNL_Seq\Ph
CfgFile = C:\Tester\AM2A1503\ISL\Settings Files\SOSRE.ini
ROI Path = C:\Tester\AM2A1503\ISL\Settings Files\subset_defs_RE.tx
Master Cine Path = C:\Tester\AM2A1503\ISL\Settings Files\MasterISL

[Camera Number and Save Range]
Camera Number = "0"
MaxSaveValue = "18050"
MinSaveValue = "-100"

[Lens Settings]
HomeFocusPosition = -2600
FocalLength = 943
FStop = 4617991057905706598

[DIC Settings]
ROI size = 19
Sigma Threshold = .07
Sigma Jump Limit = .02
Correlation Criterion = ZNNSD
Search window = 0

[Cine Parameters]
Imwidth = "896"
ImHeight = "400"
FrameRate = "10000"
Exposure = "50000"
EDRExposure = "0"
ImDelay = "0"
PTFrames = "19000"
ImCount = "65776"
SyncImaging = "SYNC_INTERNAL"
```

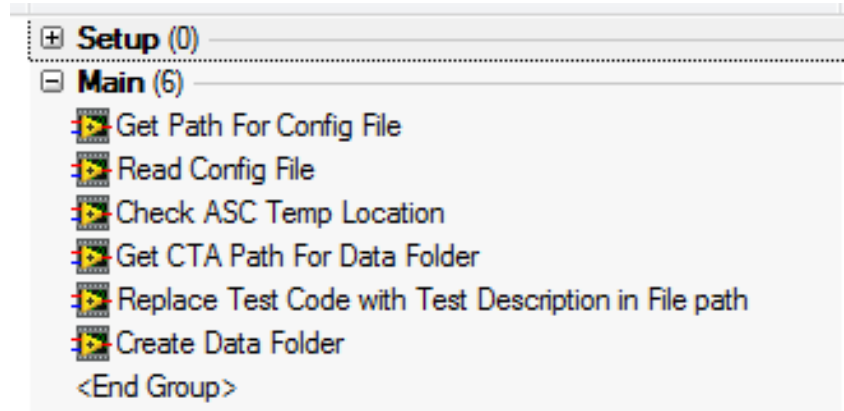

Setup (0)

Main (6)

- ▶ Get Path For Config File
- ▶ Read Config File
- ▶ Check ASC Temp Location
- ▶ Get CTA Path For Data Folder
- ▶ Replace Test Code with Test Description in File path
- ▶ Create Data Folder

<End Group>

Camera Control

- Live Image and Test Description are provided
- In this state the Camera waits for a trigger supplied from the main tester

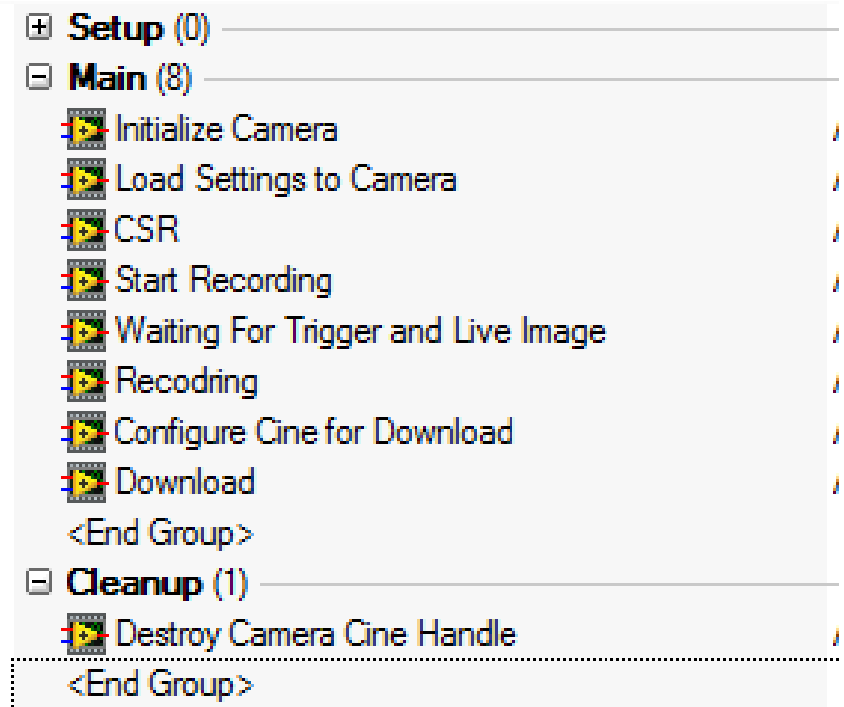

Camera Control Software

Camera

Live Image For **Part # -Test Run**

Current Date/Time: 15:31:05.4
08/12/2013

Run New Unit

Exit

Waiting For Trigger



Camera Control-MainPanel and Analysis.vi

File Help

Camera



Waiting 00:Seconds...

Current Date/Time: 15:25:34.6
08/12/2013

Run New Unit

Exit

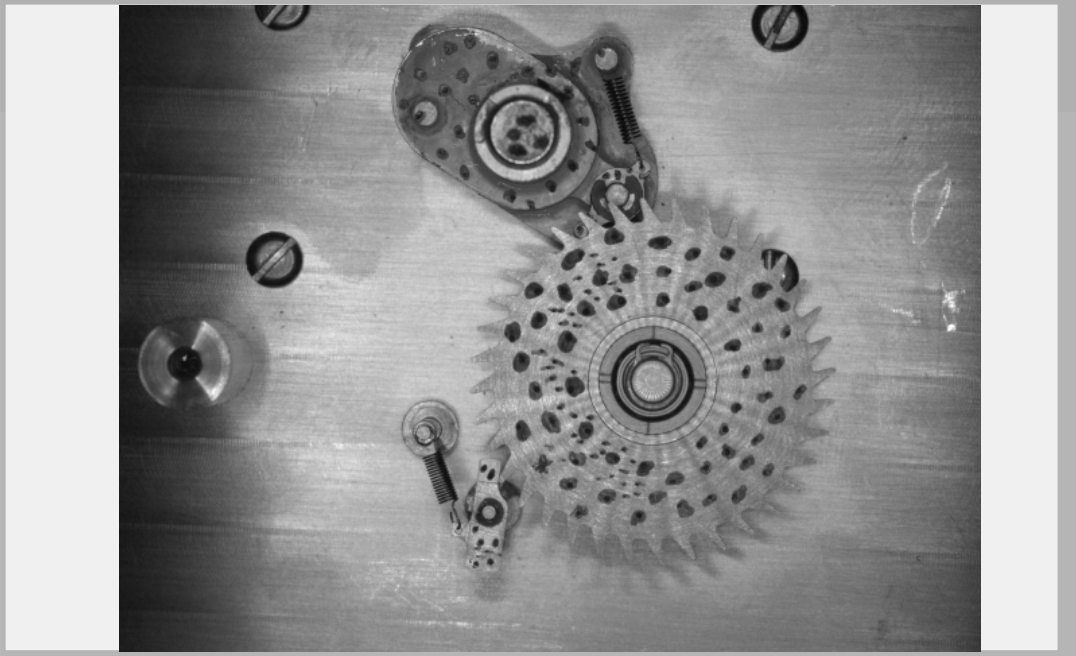
Waiting For Trigger



[Architecture-TSL or ISL\hpro\My Computer]

Registration to Adjust ROI's

- Need to adjust ROI's due to variability in unit position
- Matlabs Registration out puts the change in: x, y, scale, and theta.
- This information is sufficient to get the ROI's to fall into the region of speckle

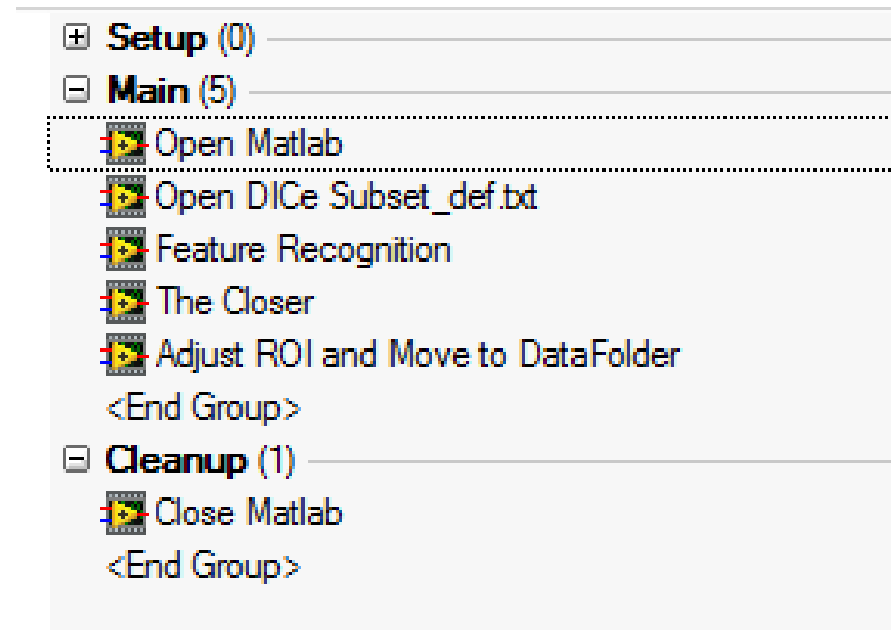

Check Cine File

- Plays back the cine and checks for errors
 - Checks to see if unit has vibrated
 - Checked to make sure cine opens and plays

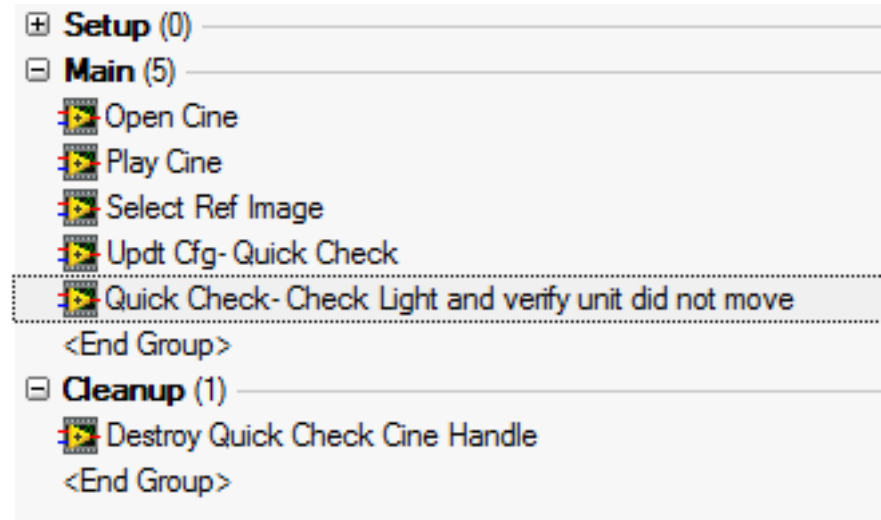

Move ASC File and ASC Analysis

- Moves ASC data from acquisition PC to Data Analysis PC
- Extracts Parameters and writes them to a file to be later limit checked against.

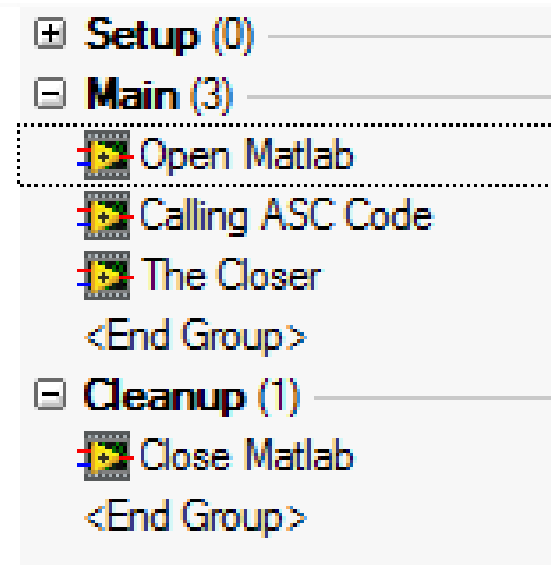
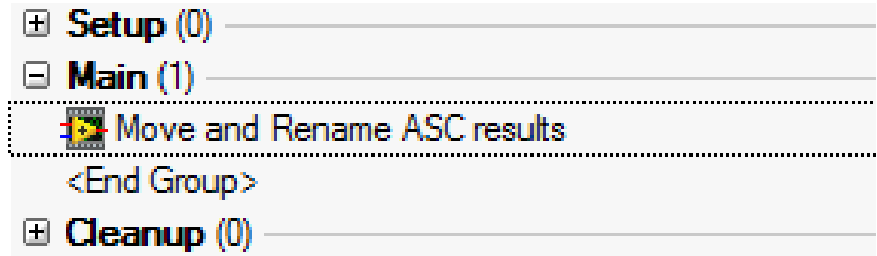

ASC Parameter Extraction Method

1. Extract Impacts from Accelerometer Signature

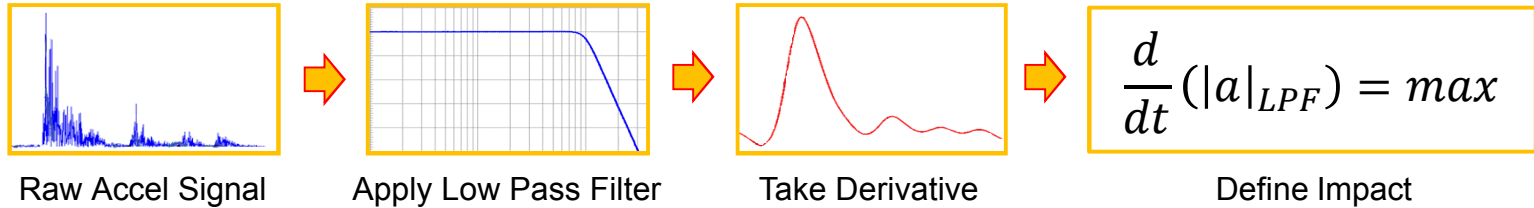

2. Calculate Parameters from Voltage Rise/Fall times and Impact Locations

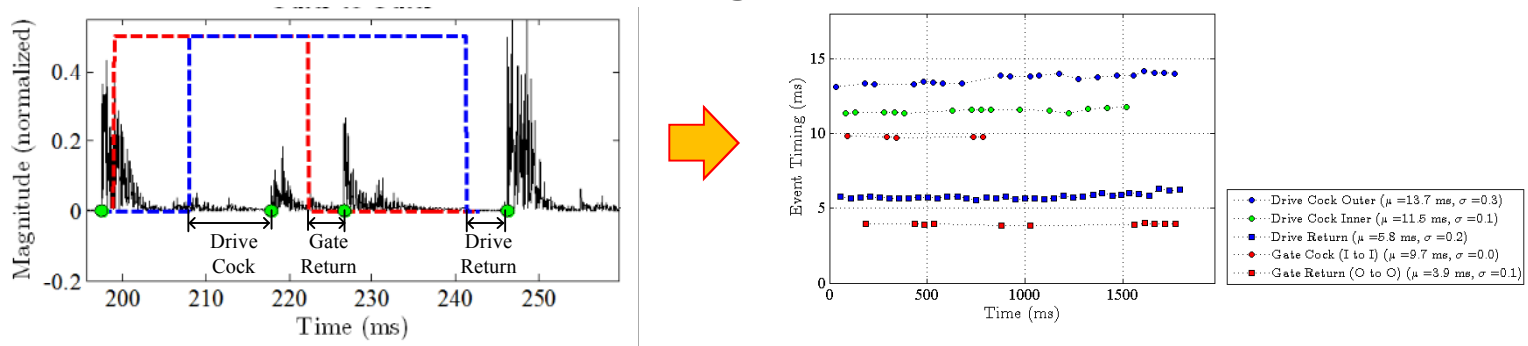

3. Calculate Population Statistics for each Signal Type

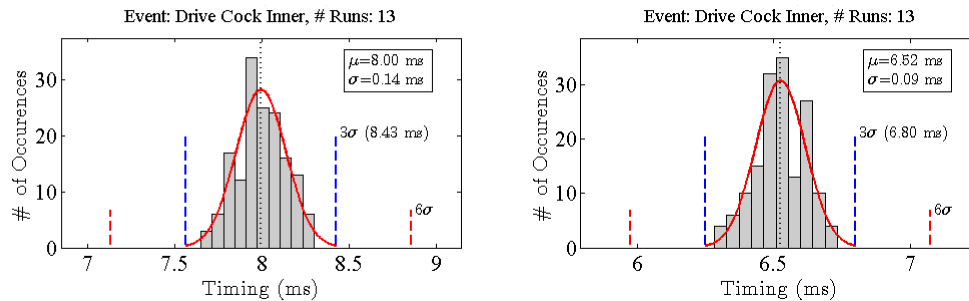

Digital Image Correlation (DIC)

- Utilizing Both Correlated Solutions DIC code and Sandia's DICe code

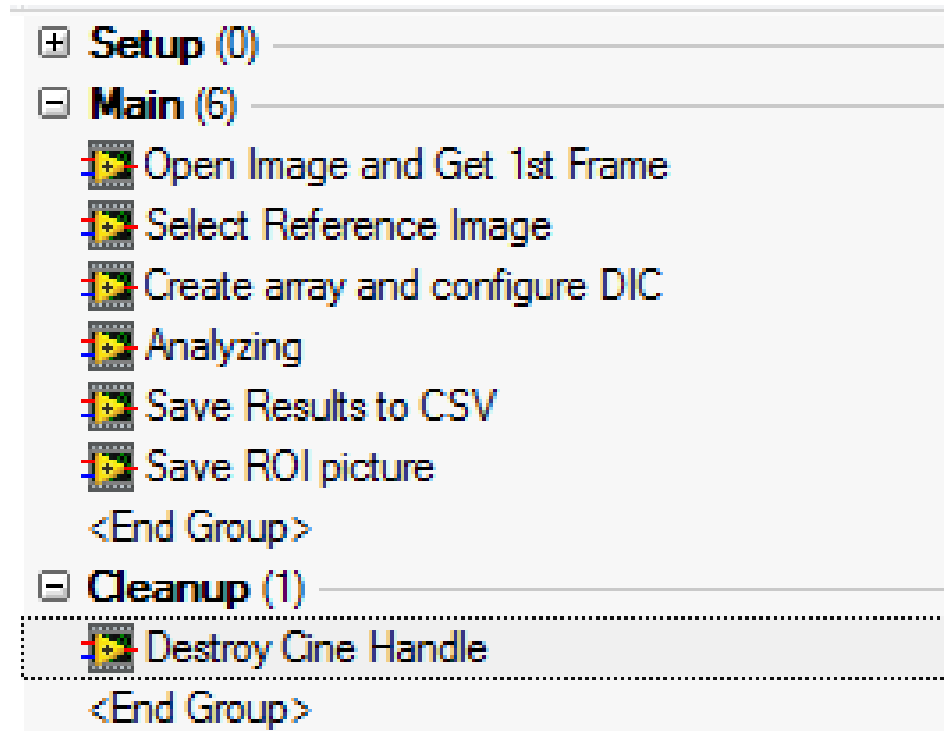

Curve Generation

- Takes Data from Pixels vs frame rate into more usable engineering data
 - Converts to Angle vs Time, Velocity vs Time, and Acceleration vs Time

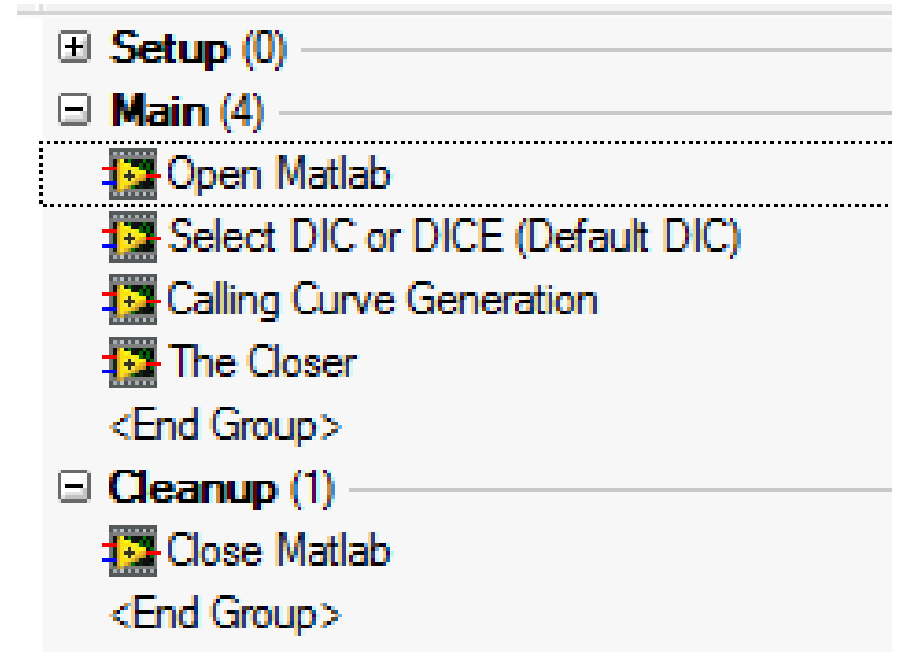

Acceptance Criteria Extraction

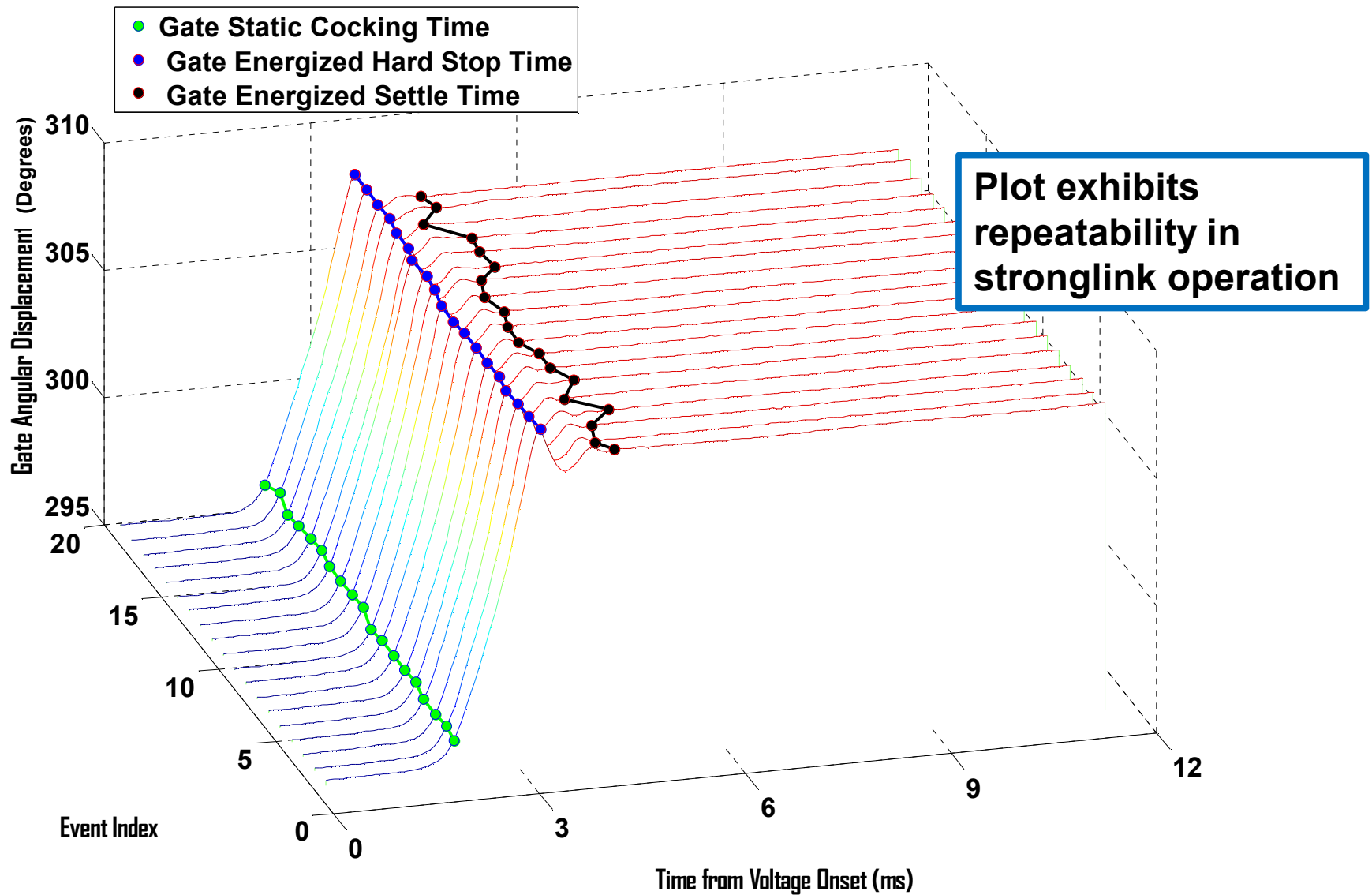

Mechanism – Motion Curves

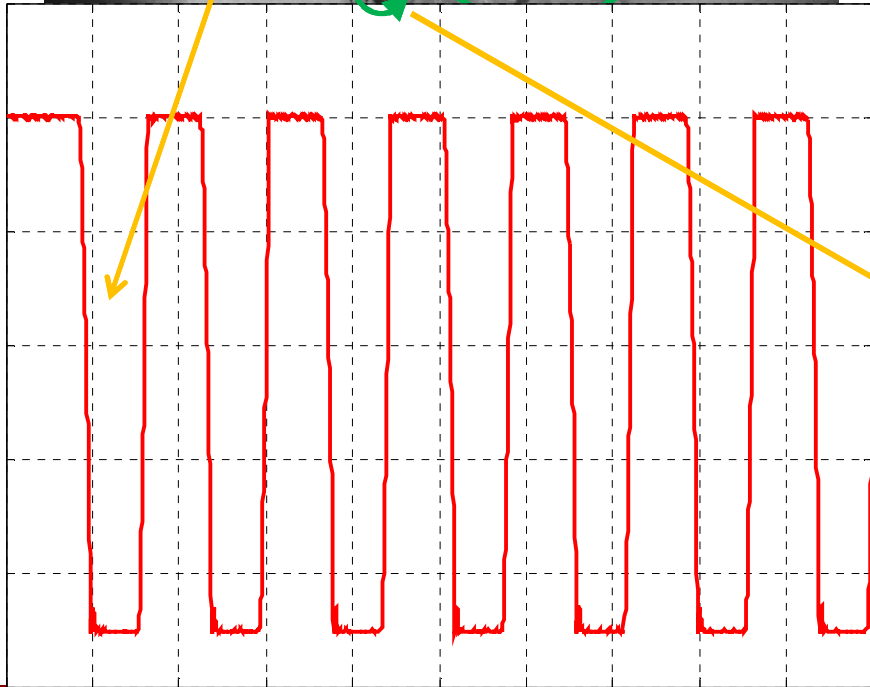
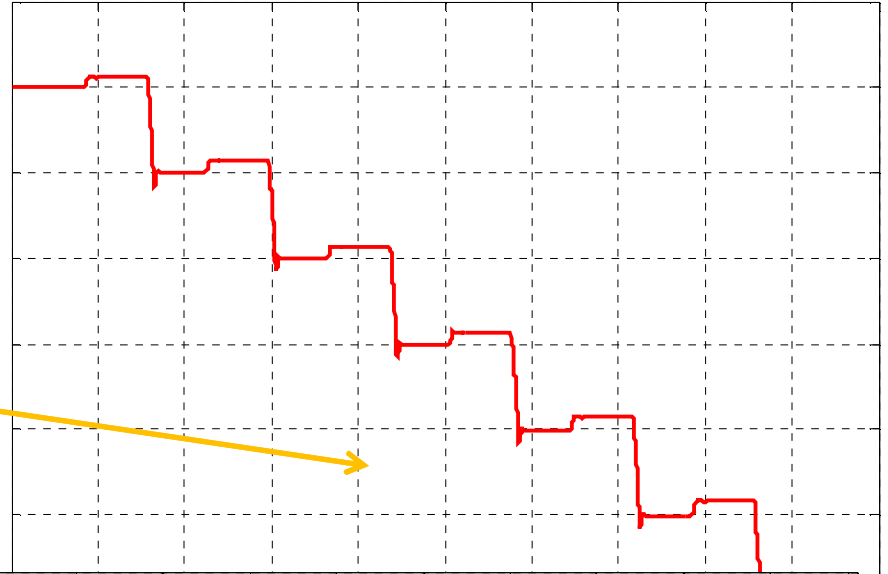
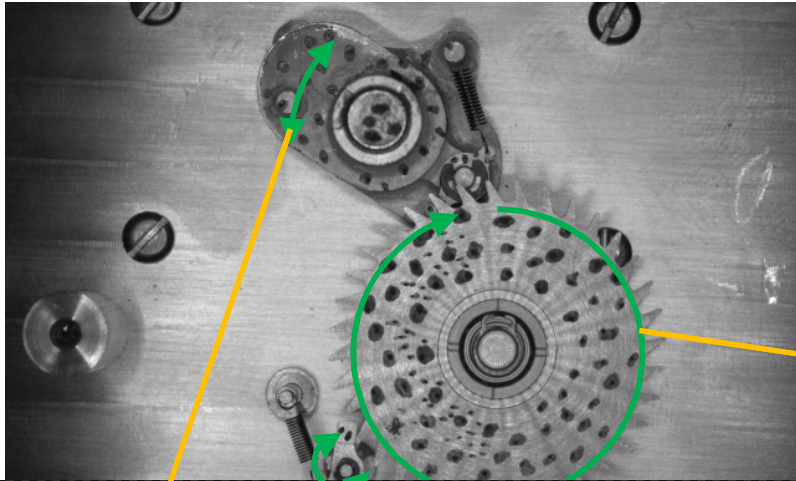

Limits Checking – For Other Mechanism

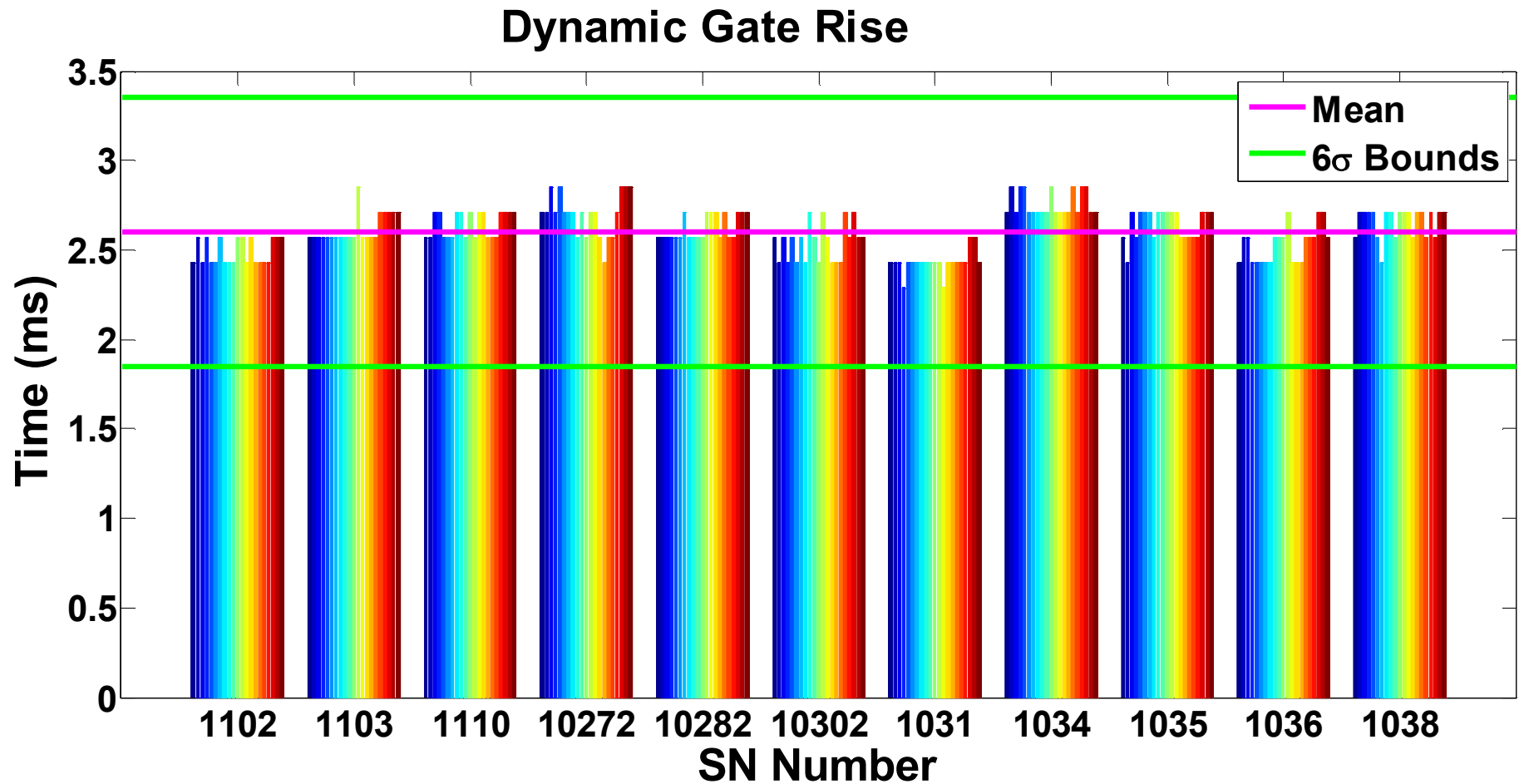

Conclusions

- DIC is automatable for complex mechanisms and tests
- Under optimized setup DIC can provide robust and repeatable tracking
- Provides high fidelity useful data to validate models
- Provide other detailed information as to a mechanisms functionality
- Can aid in detection of mechanical abnormalities

Questions??

Scott Walkington
swalkin@sandia.gov
1-505-284-9331

Miguel Palaviccin
mpalavi@sandia.gov
1-505-845-9963

Alvaro Cruz-Cabrera
aacruz@sandia.gov
1-505-845-2024