

# Battery Electric and Hybrid Vessels in Norway and Denmark: Ampere, Vision, and HH Ferries

---

**Joe Pratt**

Sandia National Laboratories

Marine Hi-Power Battery Workshop  
DOT/MARAD Headquarters, Washington DC

December 15, 2016



# The Ampere



H<sub>2</sub>FC

# Vessel



- 120 cars, 350 passengers
- 10-12 knots
- Part of the Norwegian highway system
- Operated by Norled

# Route

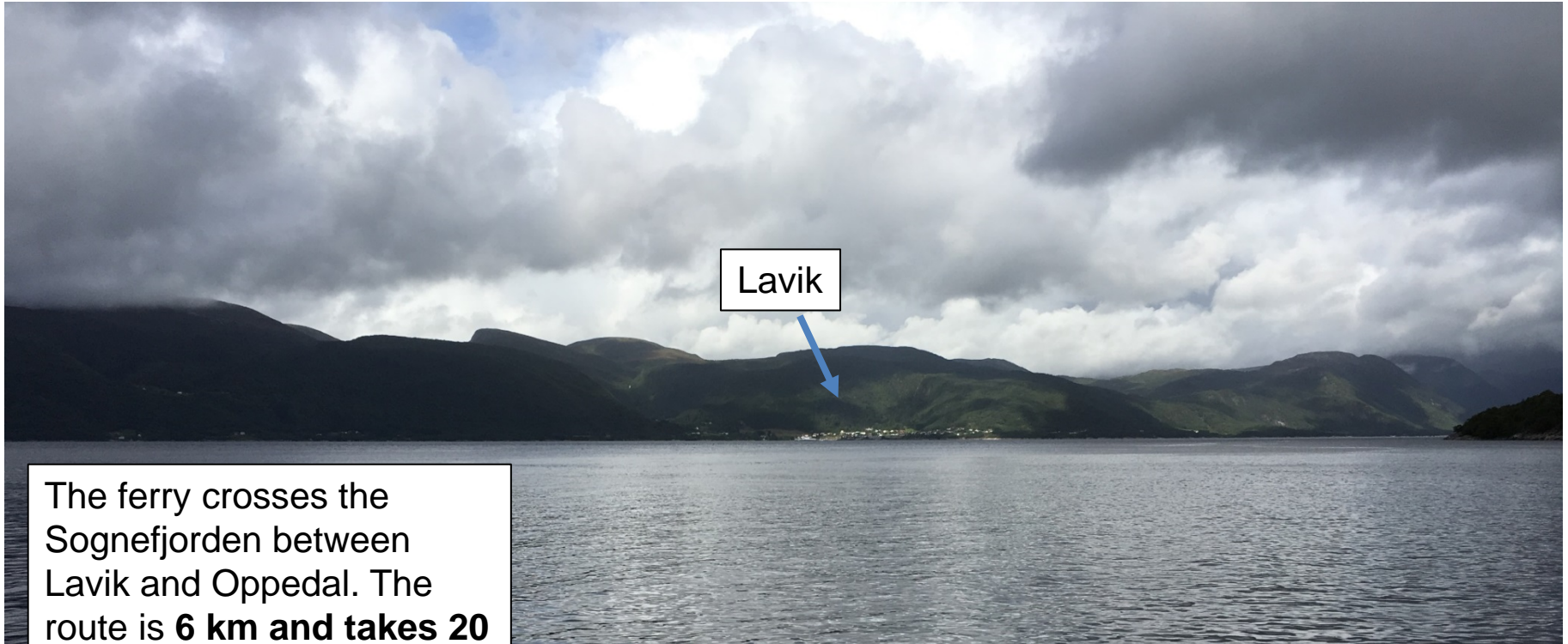

The ferry crosses the Sognefjorden between Lavik and Oppedal. The route is **6 km and takes 20 minutes to cross**. There is a **10 minute turnaround** on each side. It uses about 150 kWhr energy each crossing.



# Dock equipment

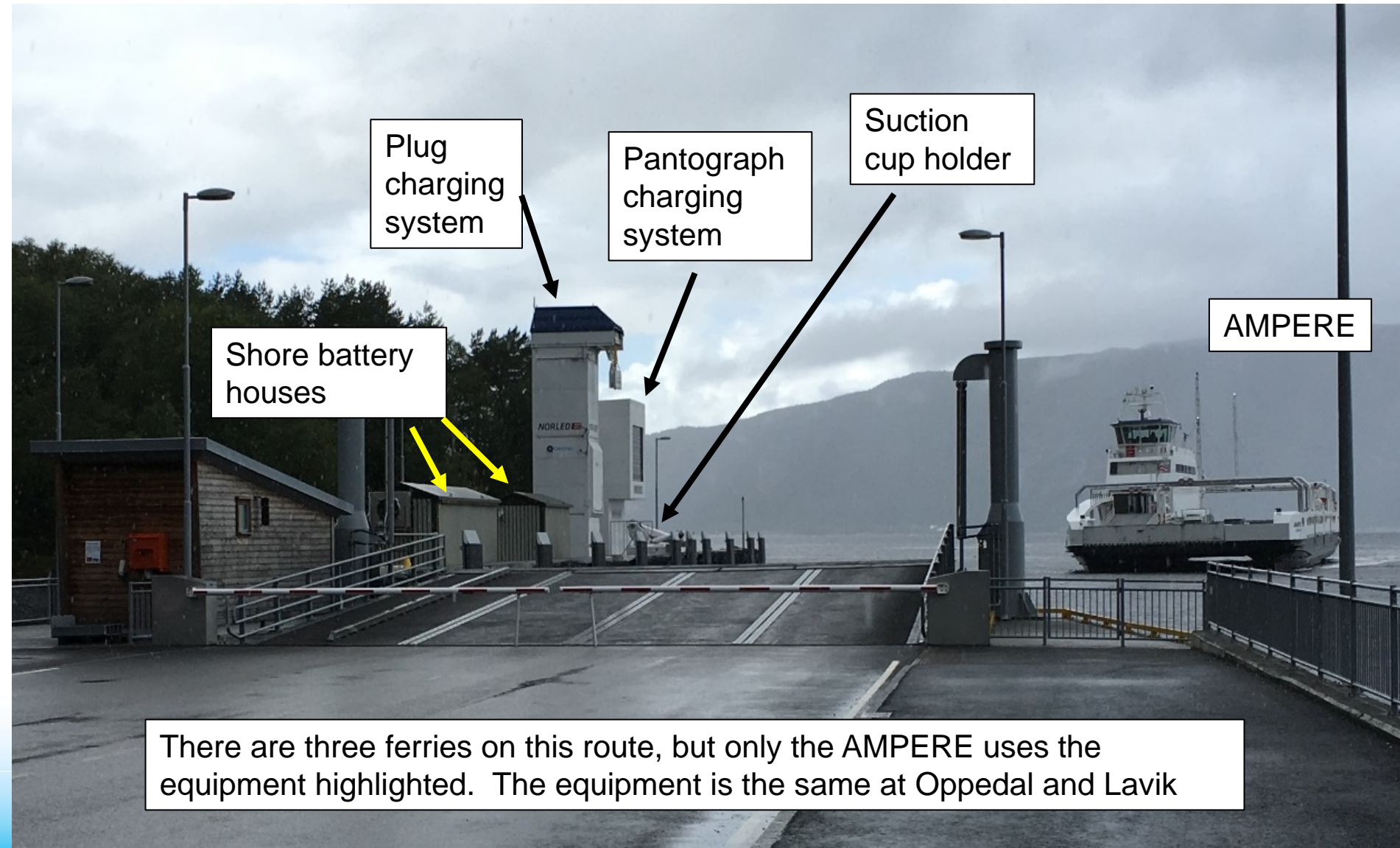

# At the dock



Hook on the bottom of the loading ramp secures the ferry's loading end against the shore

Both measures are needed to ensure the electrical connection remains secure throughout the time at the dock

Suction cup along the side secures the ferry's side against the dock



# Charging

The pantograph system is preferred because it is faster to connect and allows for more motion of the ferry when docked. On the plug system the operator has to wait for the arm to extend and lower the plug. Also the plug does not have much flexibility so if the vessel rocks the plug can come loose, interrupting the charge and damaging the contacts

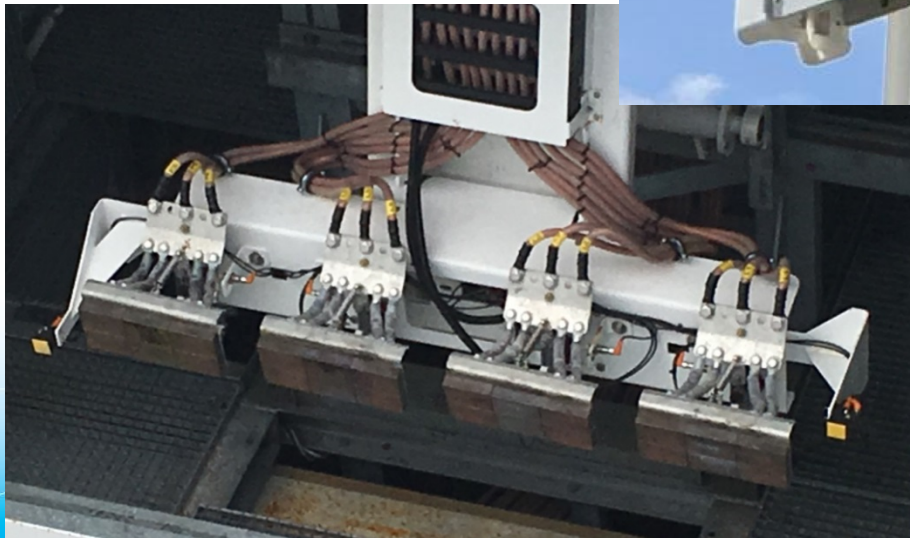

# Charging

Charge about 10 minutes each time it docks, receiving up to 200 kWhr (~1.2 MW rate). Electricity comes from the batteries on shore because the local grid cannot support this much power.

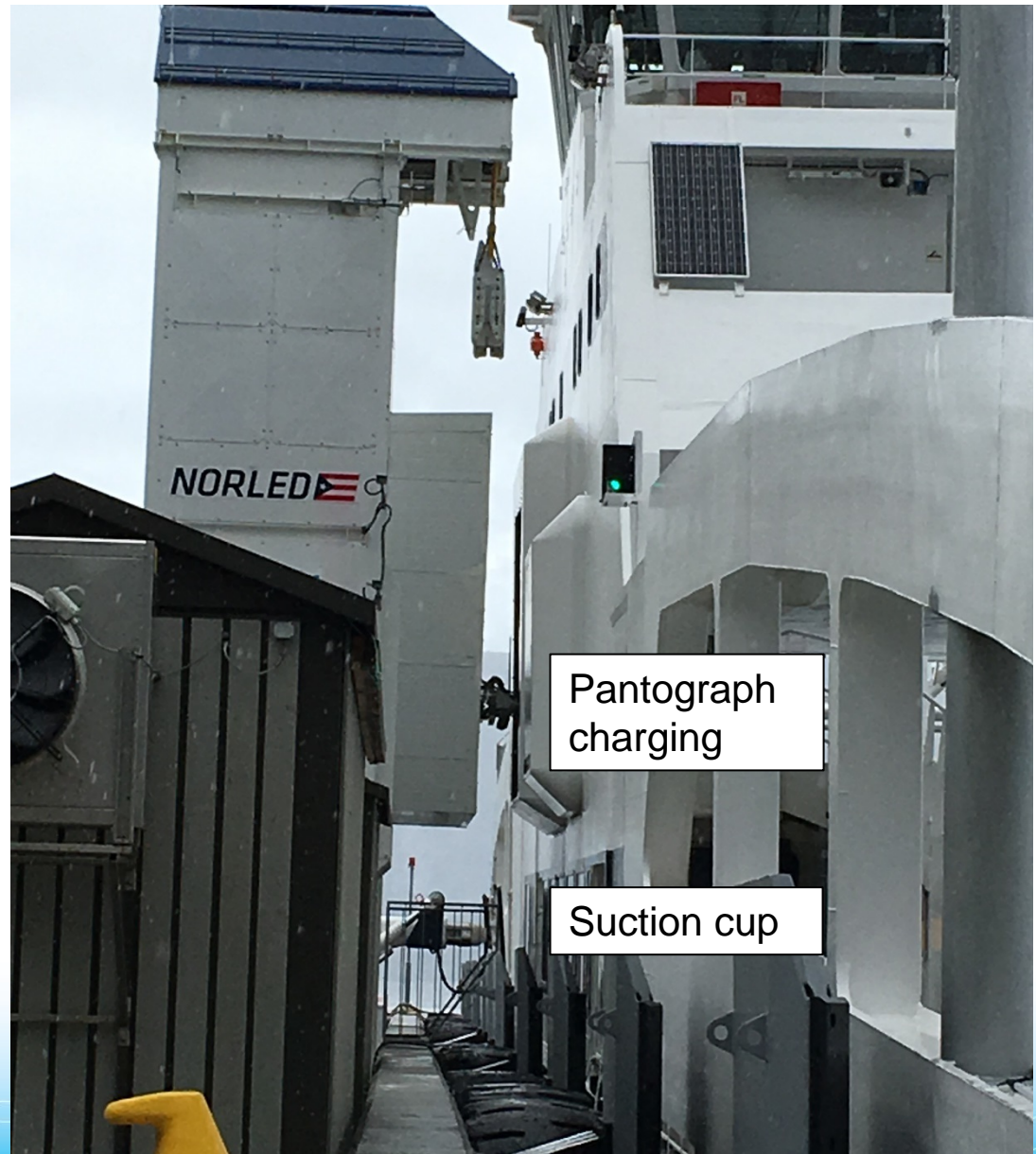

Pantograph charging

Suction cup

# Batteries

- 2 independent battery rooms
- 4 banks in each room
- 15 batteries in each bank
- Corvus model AT6500-250-48, 6500 Wh rated capacity
- 10 year life

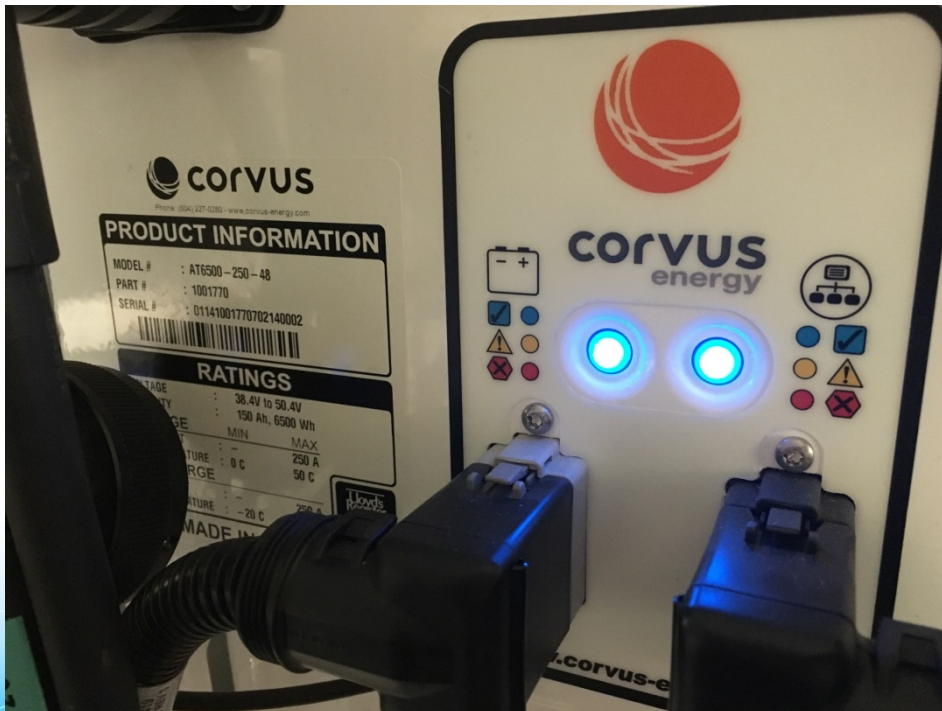

# Drivetrain

- 2 independent engine rooms
- 1 x 450 kW motor in each room
  - 620 VAC
  - 520 A
  - Siemens
  - 2,700 kg
  - Regular grease/oil checks
  - 50,000 maintenance interval (bearings)
- 1 azimuth thruster

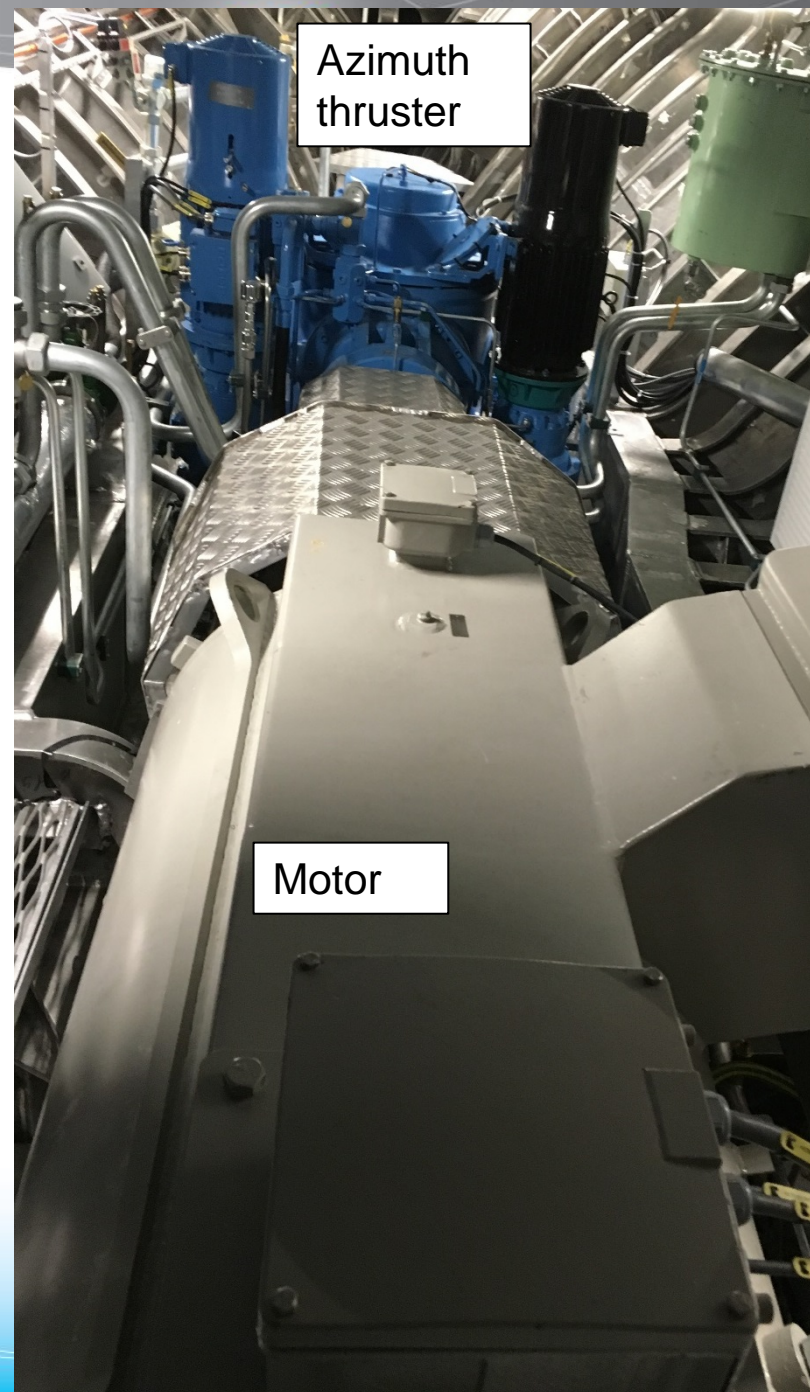

# Thank you Norled and DNV-GL

- Frank Kristiansen, Chief Engineer, Norled
- Arne Hopland, Principal Surveyor, DNV-GL



Arne Hopland and Tom Escher

# The Vision of the Fjords



# Vessel

- Carbon fiber catamaran
- Diesel electric hybrid
- 400 passengers
- Panoramic windows
- Full disabled access
- Owned/operated by The Fjords



More vessel design info: <http://www.seasight.braa.no/>

# Route

The boat cruises between Flam and Gudvangen, Norway. The main point of the trip is the part through the Nærøyfjord, a UNESCO World Heritage site.

One-way route profile:

- Flam to entry of Nærøyfjord
  - Diesel engine
  - 30-40 minutes
  - 18-19 knots
- **Through Nærøyfjord to Gudvangen**
  - **Battery only**
  - **50 minutes**
  - **8-11 knots**

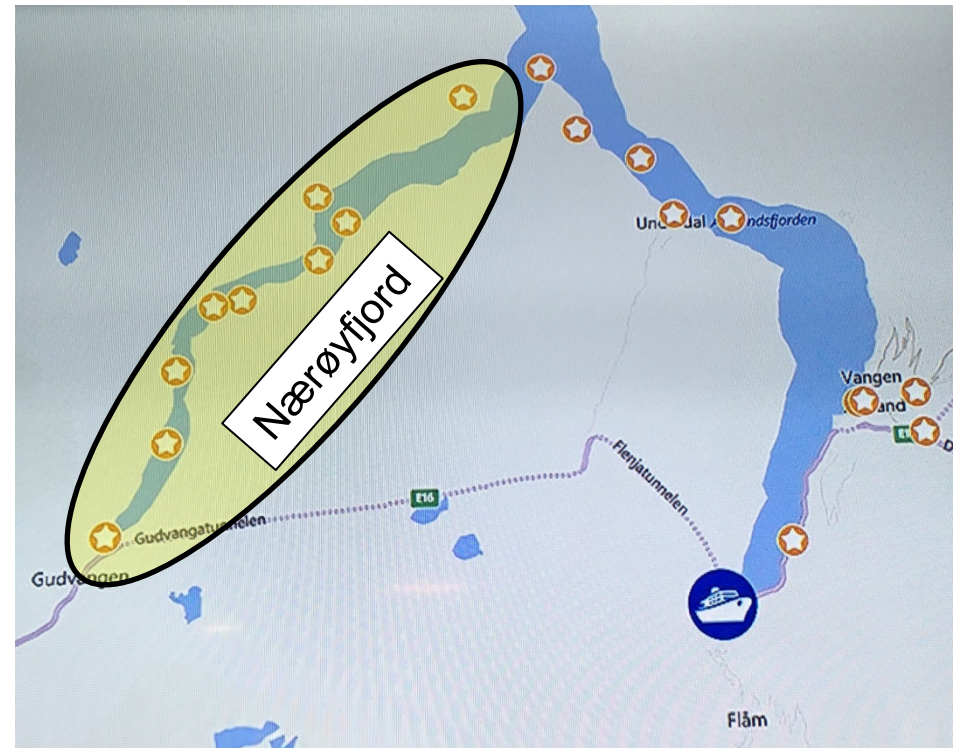

# Dock equipment



Flam



Gudvangen

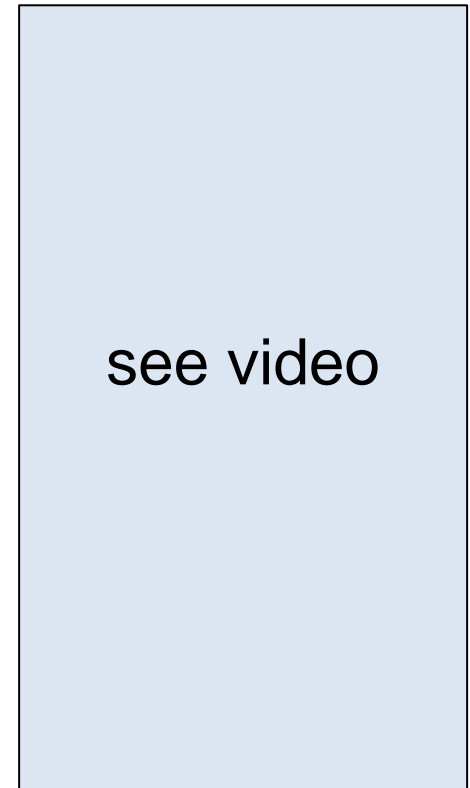

Procedure

Only dockside equipment is the cable reel/crane

# Charging

- The cables weight about 3 kg/m and the connectors about 10 kg each.
- The cables are not very flexible and do not have play in them – because of tides they do not charge overnight.
- Operator would prefer fully automated system with a single plug requiring only one crew and one connection.
- Each cable is 440 VAC / 600 A, total 528 kW
- Charge time is dictated by schedule, not optimized for the electricity needed. Sometimes do not get necessary charge.
- Shore-side voltage limits charging to 77% maximum. Installation of a converter could increase this to 100%.



# Batteries



- Battery system by ZEM
- Batteries from LG Chem
- 15 batteries per rack
- 7 racks per bank
- 288 kWhr per bank
- 1 bank each hull



# Drivetrain

2 independent engine rooms

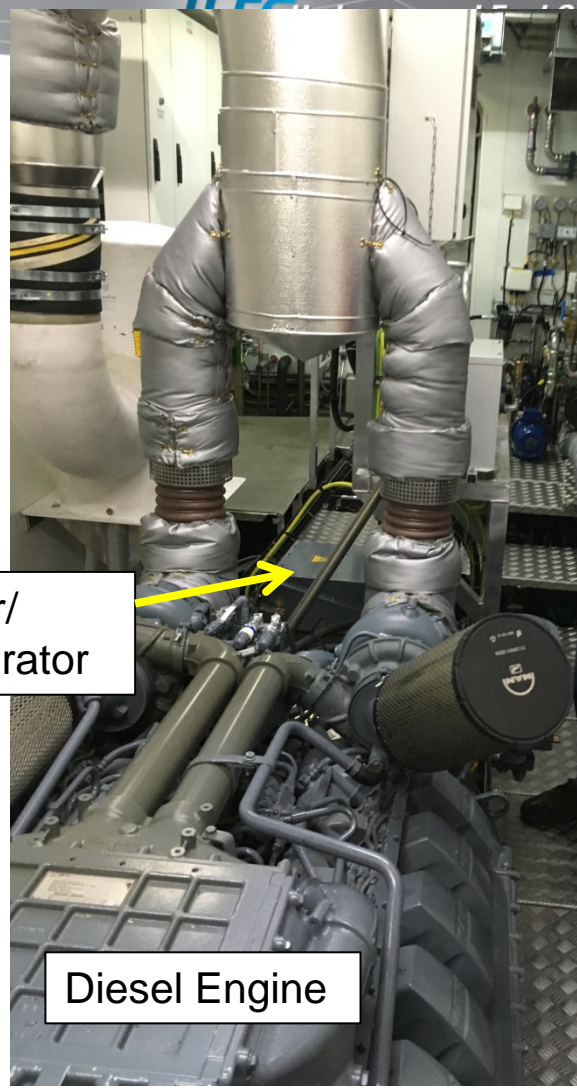
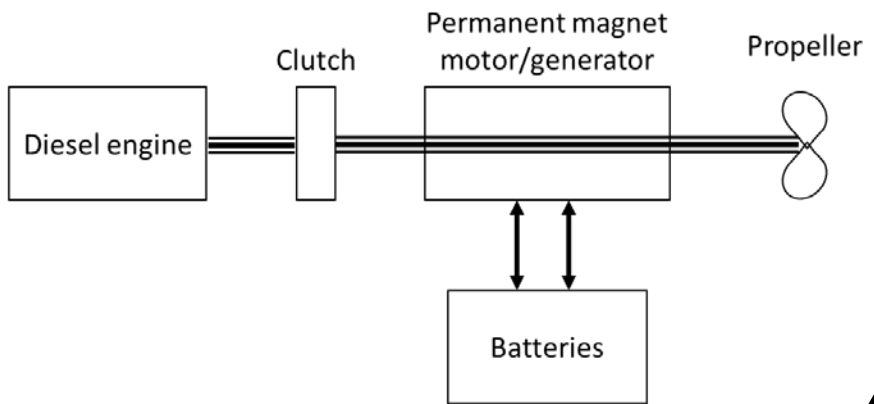

Motor/  
Generator

Diesel Engine

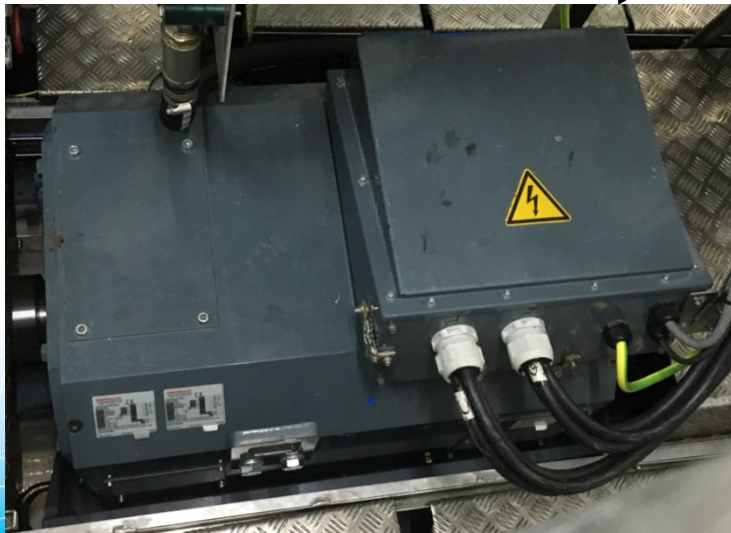

**OSWALD**  
ELEKTROMOTOREN GmbH  
D - 63897 MILTENBERG / MAIN

Synchronous Generator

MFS25.35-8W	U 3x	/ 420 V Δ
Ser.No. 172775-	Ins. Cl. F	P / 209 kW
Part No. 0885-00001	Vib. Cl. R	I / 295 A
Cust.No. 0885-000001	IP 56	f / 140 Hz
Rating S1	m 1135 kg	n / 2100 rpm
$f_{max/min}$	153.3 Hz / 2300 rpm	cos φ / 0.95
$M_{max/min}$	Nm / A	
Altitude	≤ 1000 m a.s.l.	Amb. Temp. ≤ 45 °C
Cooling	water cooled	IC 71W
Material: copper, Medium: water, inlet temperature: max. 25°C, Menge: app. 12 l/min, dp: app. 1.5 bar, max. pressure: 8 bar, - DNV GL N1418918		
Made in Germany www.oswald.de IEC 60034		

**OSWALD**  
ELEKTROMOTOREN GmbH  
D - 63897 MILTENBERG / MAIN

Synchronous Motor

MFS25.35-8W	U 3x	/ 240 V Δ
Ser.No. 172775-	Ins. Cl. F	P / 150 kW
Part No. 0885-00001.m	Vib. Cl. R	I / 440 A
Cust.No. 0885-000001	IP 56	f / 73.3 Hz
Rating S1	m 1135 kg	n / 1100 rpm
$f_{max/min}$	Hz / rpm	cos φ / 0.85
$M_{max/min}$	Nm / A	
Altitude	≤ 1000 m a.s.l.	Amb. Temp. ≤ 45 °C
Cooling	water cooled	IC 71W
Material: copper, Medium: water, inlet temperature: max. 25°C, Menge: app. 12 l/min, dp: app. 1.5 bar, max. pressure: 8 bar, - DNV GL N1418918		
Made in Germany www.oswald.de IEC 60034		

# Thank you The Fjords crew and DNV-GL

## The Fjords

- David Westgård Jansson  
Chief Engineer
- Arvid Langteig, Captain
- Anu Pietiläinen, Chief Mate  
DNV-GL
- Arne Hopland, Surveyor



David Jansson, Captain Langteig, and Tom Escher

# HH Ferries

Information and graphics from ABB:

<http://new.abb.com/marine/references/hh-ferries>



# Vessels

- Vessel conversion project from diesel powered to 100% battery electric
- Diesel generators remain on-board as backup

## M/F Tycho Brahe

- Built 1991
- Length 111 m
- Breadth 28 m
- Draft 5,3 m
- Cars 238
- Passengers 1 100
- Lanemeters 539 m



## M/F Aurora

- Built 1992
- Length 111 m
- Breadth 28 m
- Draft 5,5 m
- Cars 240
- Passengers 1 250
- Lanemeters 528 m



<http://new.abb.com/marine/references/hh-ferries>

<http://hhferriesgroup.com/about-hh-ferries-group/ferries/>

# Route and Logistics

- Departure every 15 minutes
- Travel time of 20 minutes.
- ~ 3 nm one-way
- ~ 12 knots top speed

## Planned Charging:

- 5.5 minutes charge at Helsingor
- 9 minute charge at Helsingborg

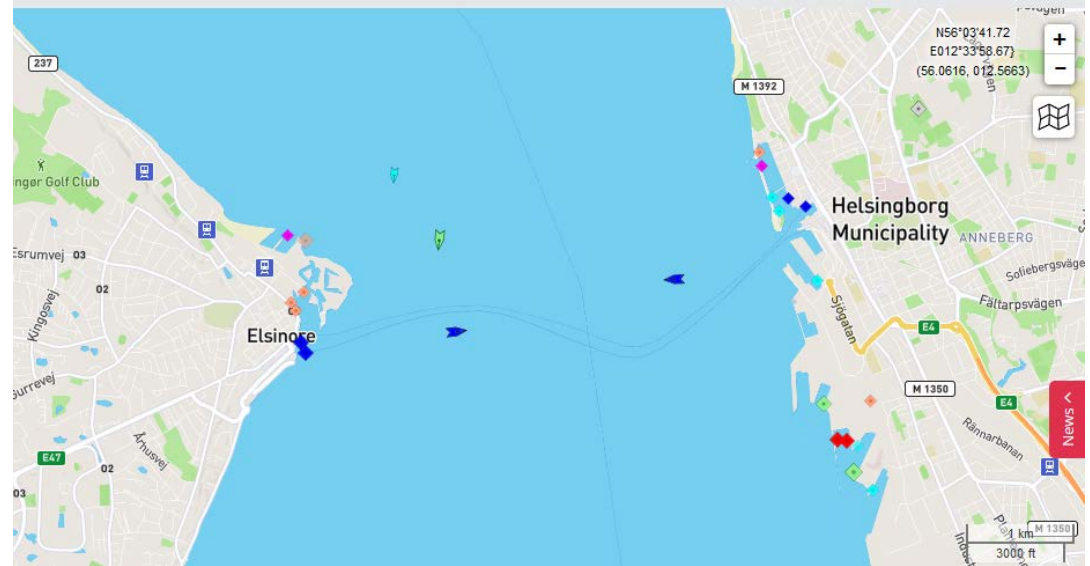

marinetraffic.com

# Equipment

## Main Components in the delivery



Co-financed by the European Union  
Trans-European Transport Network (TEN-T)

### Robot

ABB



### Onboard DC Grid

ABB

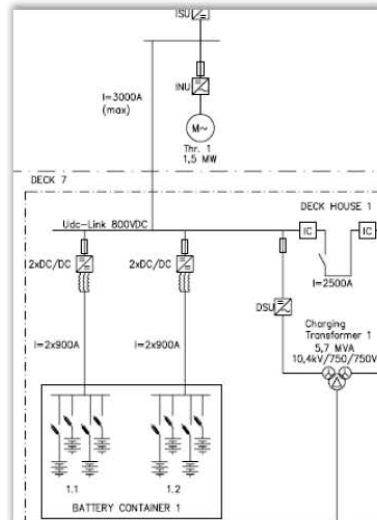

### Batteries

PlanB e Storage Ltd



### Energy Storage Control System

ABB



# Charging

Robot in action: <https://youtu.be/krJTdCFxupo>

Search: "ABB's shore connection robot"

## Automated shore-side charging station



Co-financed by the European Union  
Trans-European Transport Network (TEN-T)

### Highlights

- Connecting cable whilst the ferry is still making the final approach to the ramp → optimize the connection time and therefore maximize charging period
- Physical cable connection → minimum energy transfer losses
- Long life time for robot and cable reel.
- The tower moves vertically based on tidal water

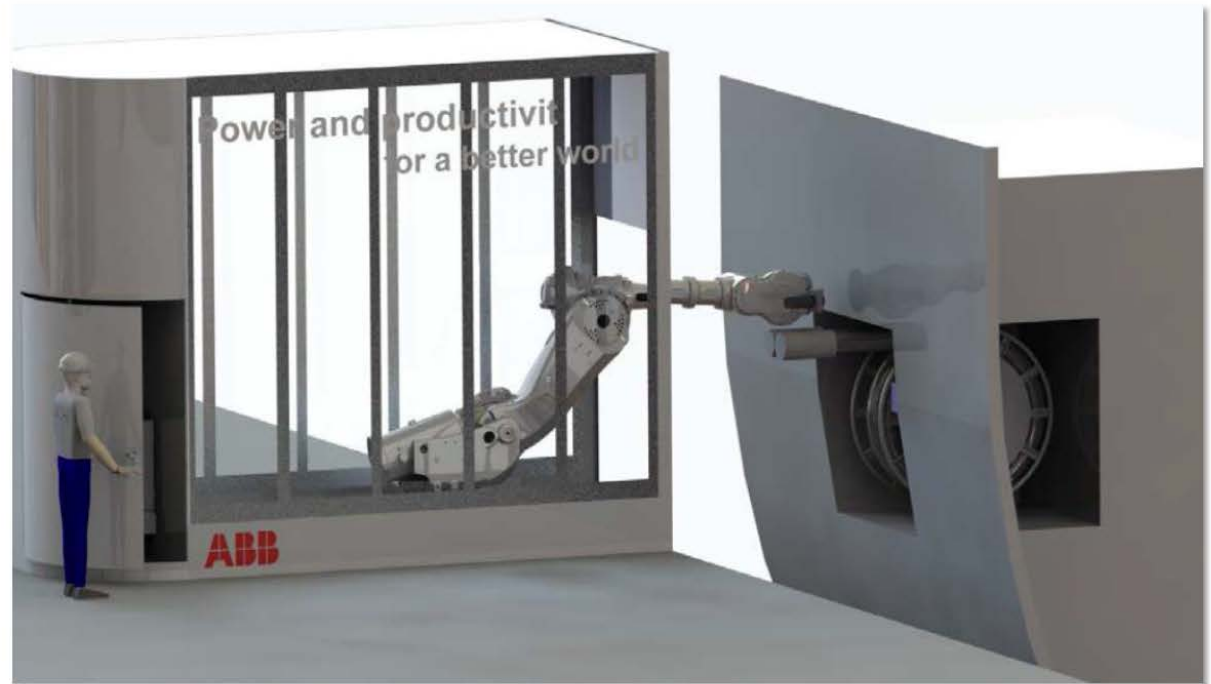

# What is the best type of zero emission ferry to build today?

