

Exceptional service in the national interest

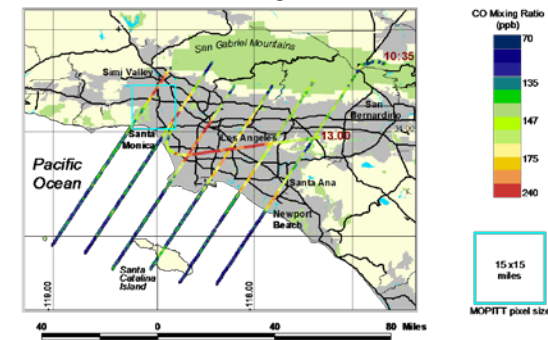
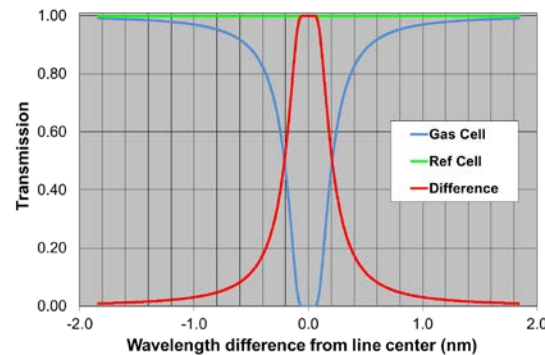
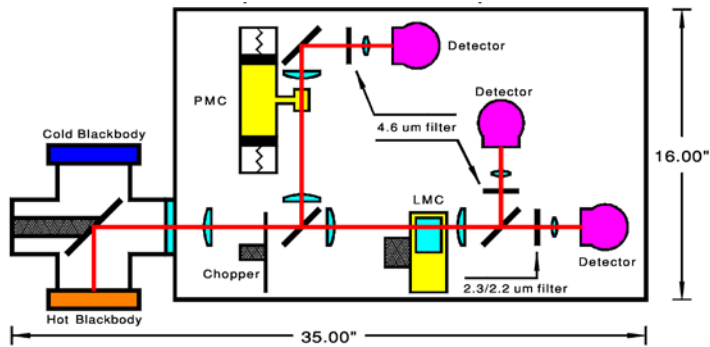

Remote sensing with gas filter correlation radiometry

Mark W. Smith, Dept. 05772
Sandia National Laboratories

Atmospheric remote sensing

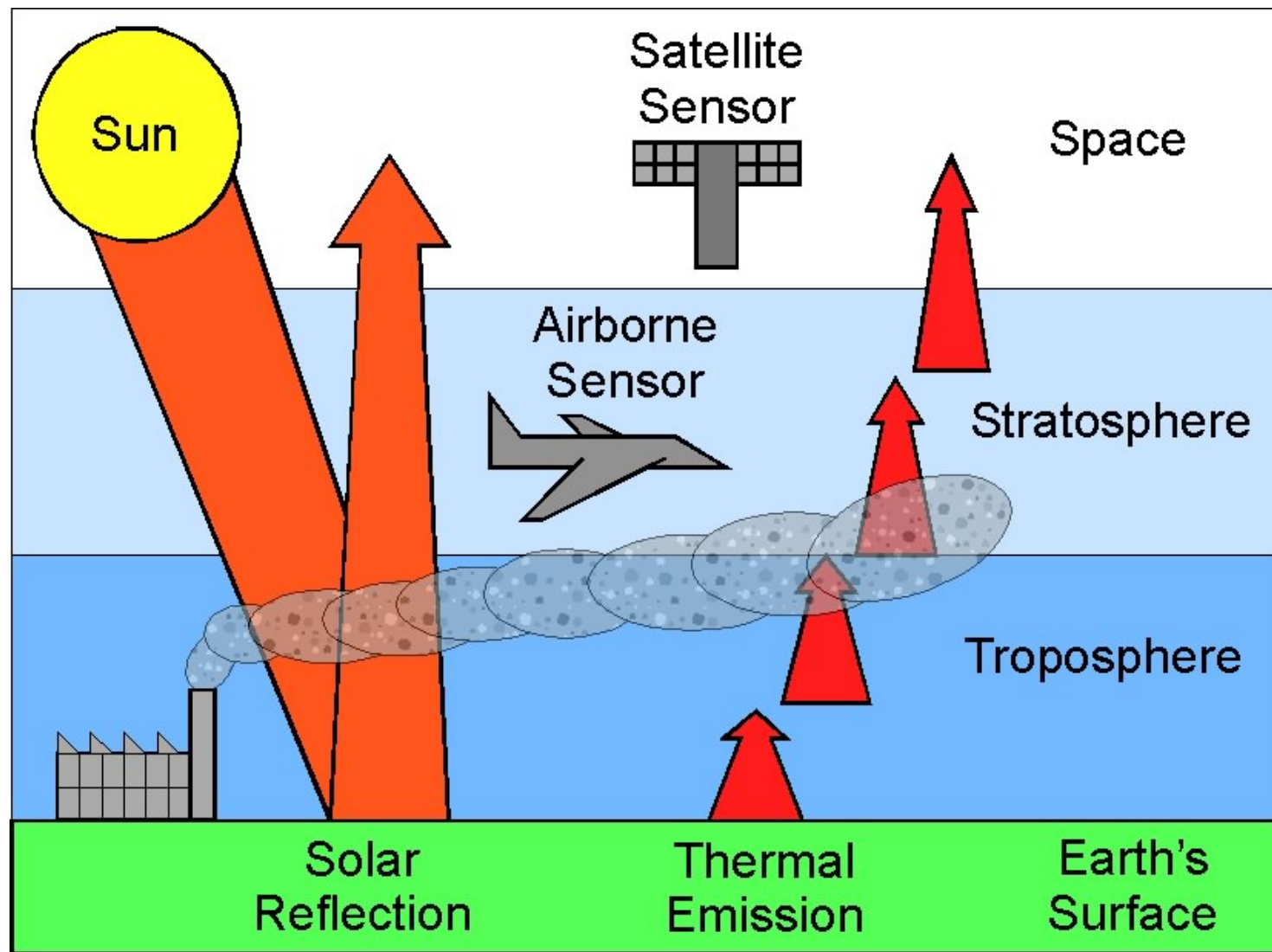

Generic gas filter correlation (GFC) optical layout

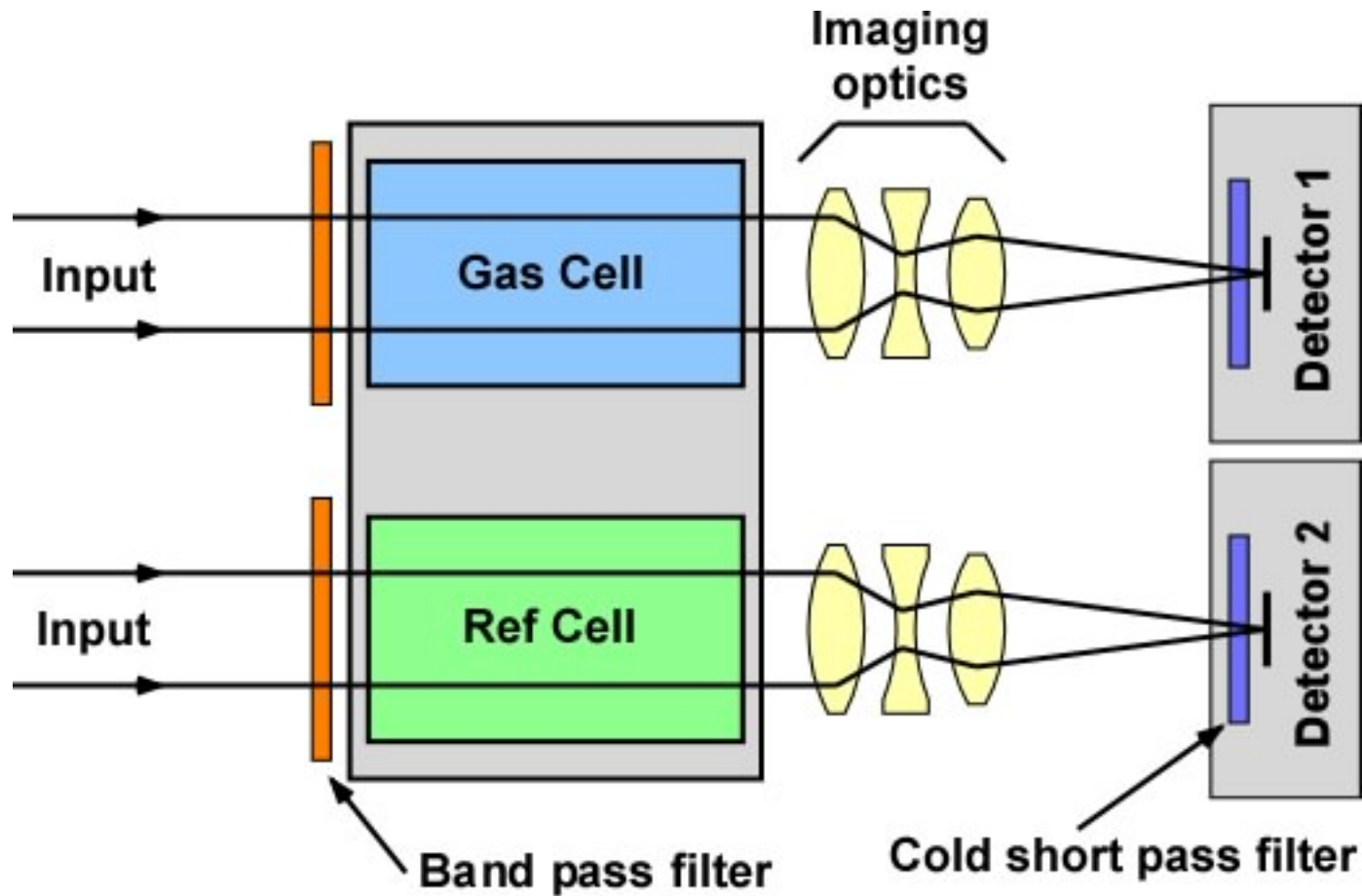

Principle of a gas correlation filter

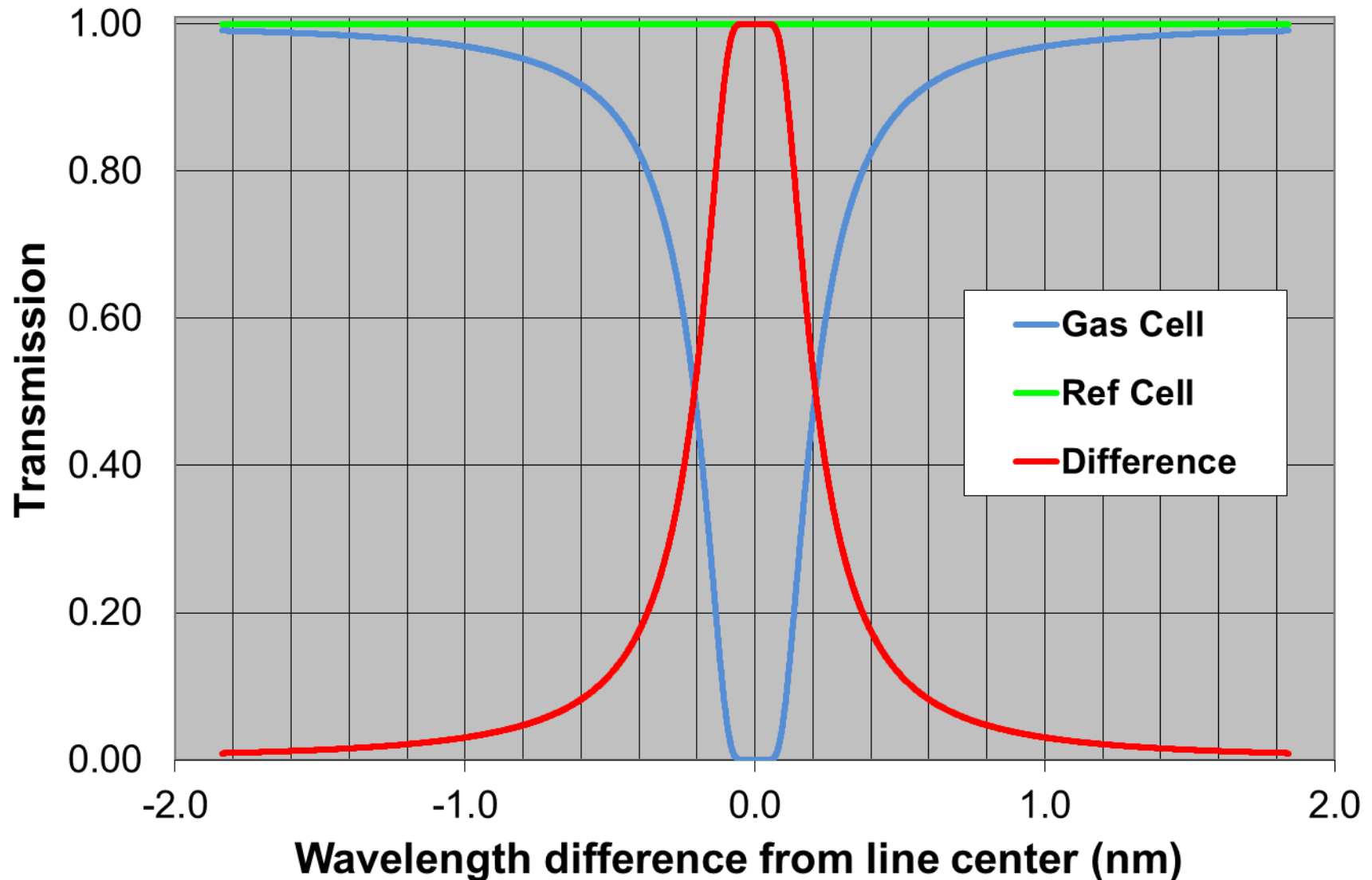

MATR optical layout

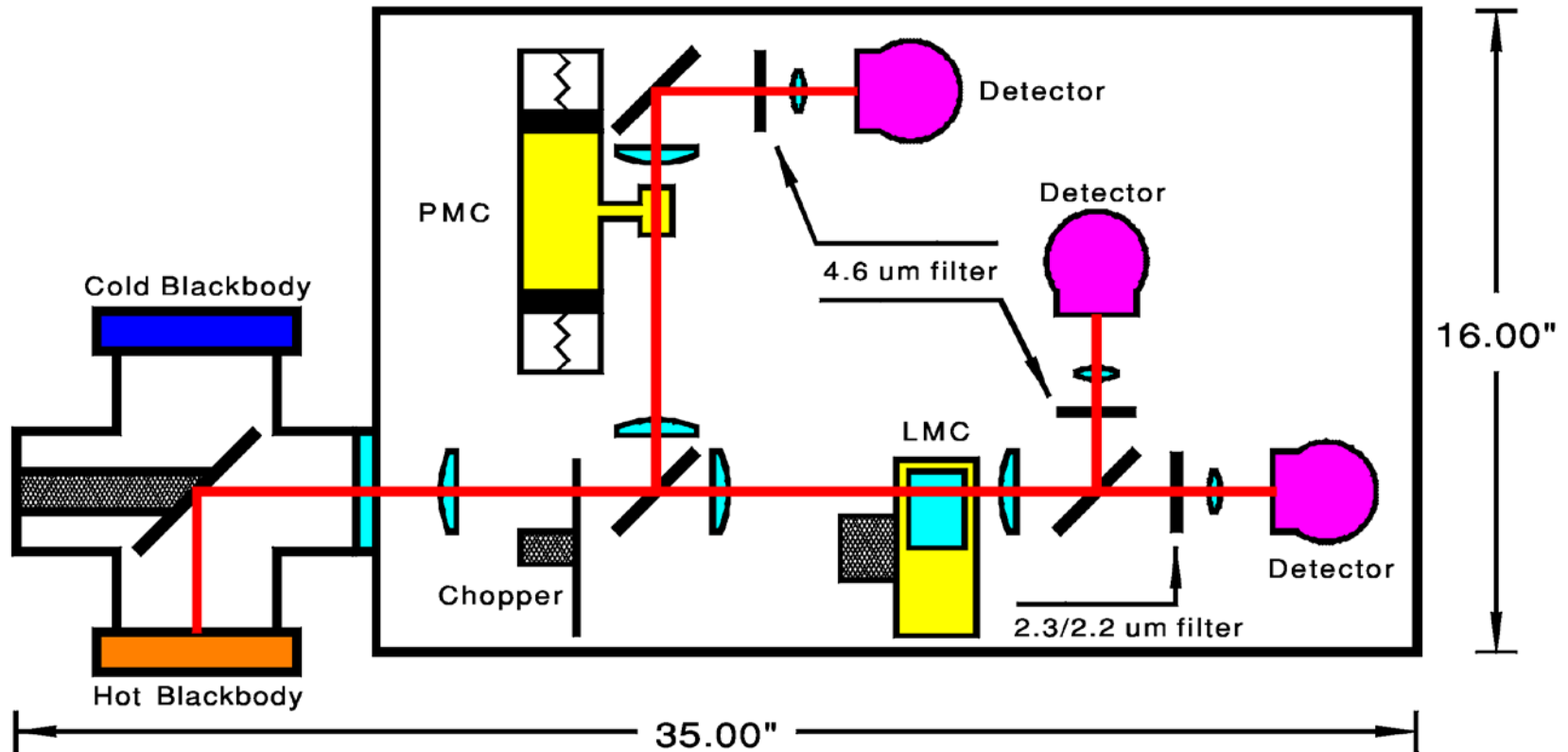

Pressure modulated cell (PMC) correlates to CO fundamental at 4.6 μm

Length modulated cell (LMC) correlates to CO first harmonic at 2.3 μm

LMC also correlates to a CH₄ overtone/combination band near 2.2 μm

MATR data from one flight

CO Mixing Ratio Over Los Angeles January 22, 1999

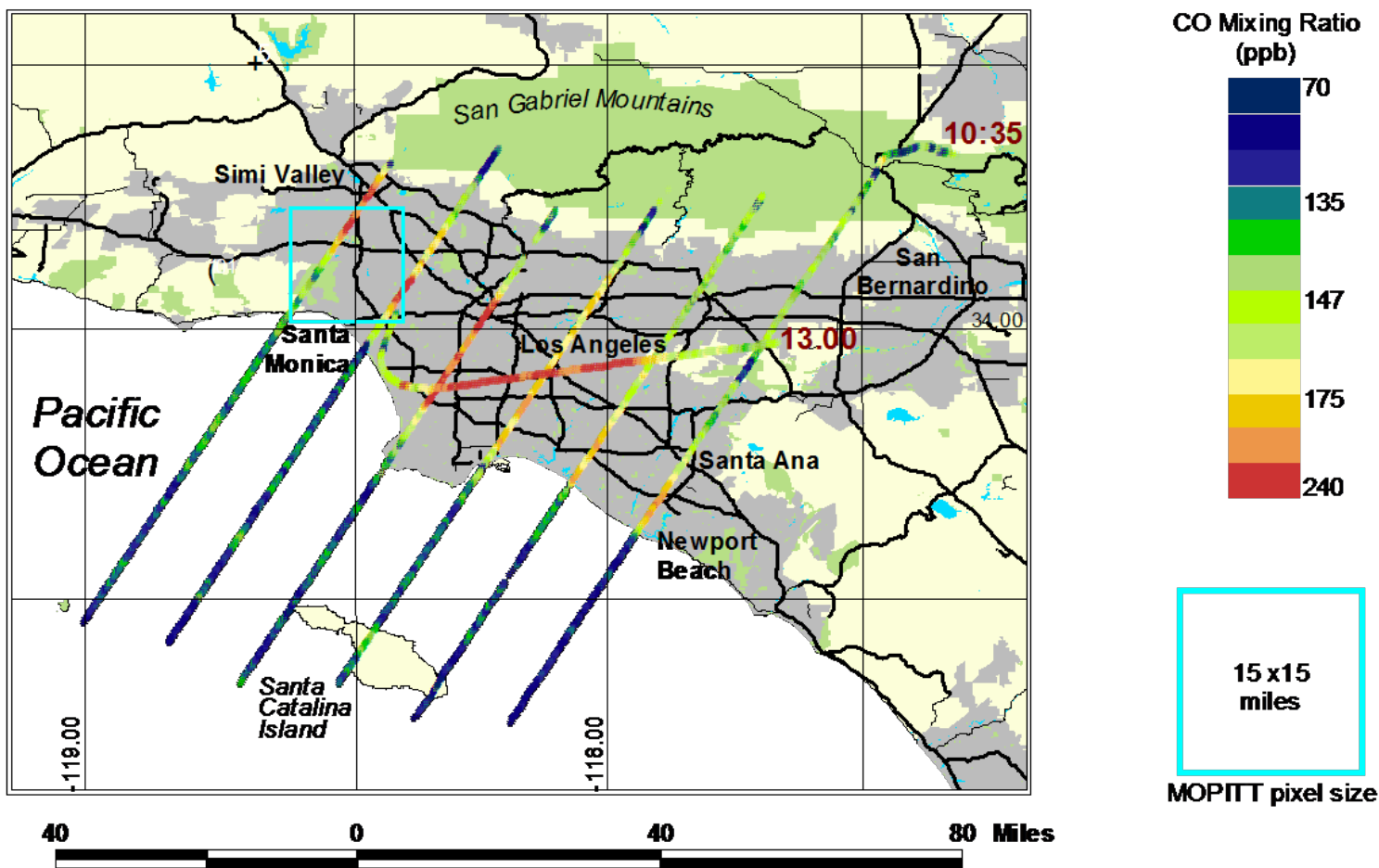

February 29, 2000

Neptune optical layout

