

# Advanced Protection Schemes for Renewable-Rich Microgrids

Mohamed El Khatib, Sukumar Brahma and Abraham Ellis  
Sandia National Laboratories, Albuquerque, NM, USA

## Introduction

Microgrids are becoming important tools to improve power grid resilience and reliability. As such, and as the size of microgrids continue to grow, it is becoming crucial to develop efficient protection schemes to selectively clear faults within the microgrid by tripping the least possible part and avoid collapsing the whole microgrid for all internal or external faults. Microgrids with significant inverter-interfaced generation are particularly challenging since fault currents could be very limited and traditional overcurrent protection could fail completely to detect faults.

## Technical Approach

There is a need to fill the gap between low-cost low-reliability schemes like overcurrent protection and high-cost high reliability schemes like differential protection.

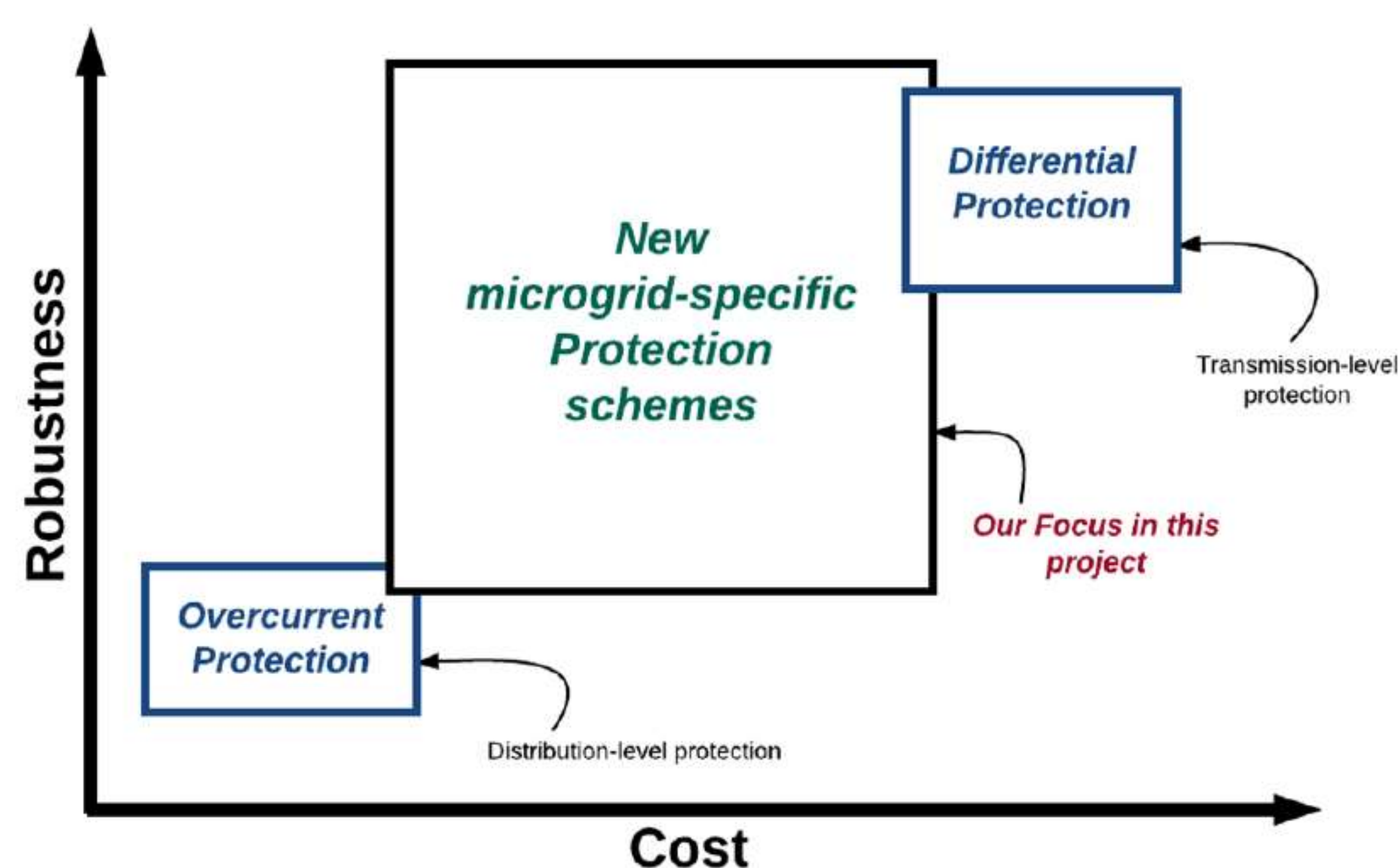

## Protection Zones

we define microgrid protection zone as:  
*a part of the microgrid bordered by a set of fault interrupting devices.*

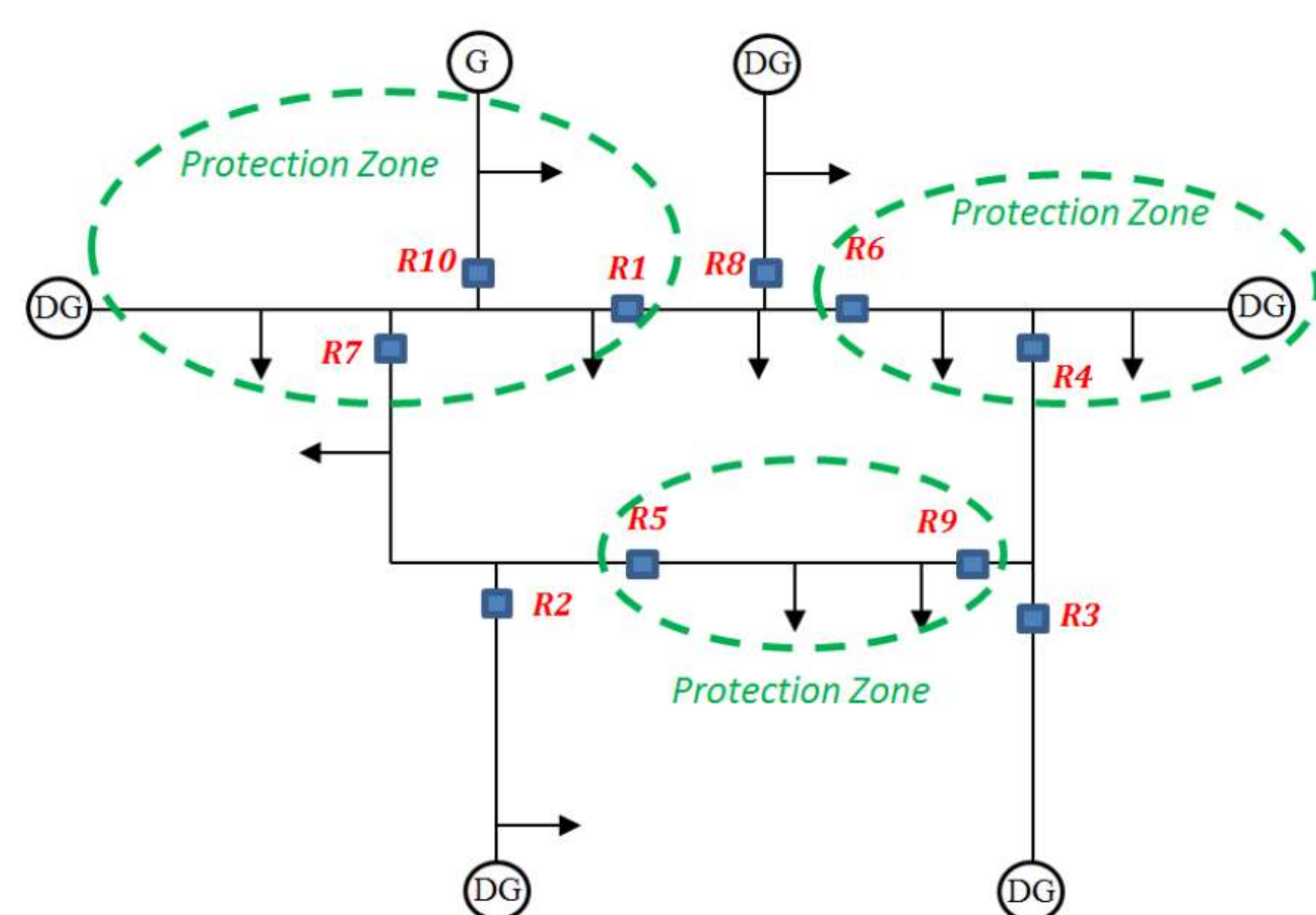

## Impedance-based Protection

Impedance relays are more effective than overcurrent for low-fault microgrids. A fault is detected if the impedance measured by a relay falls below its impedance threshold value. Pilot-schemes combining impedance and directional elements were developed to reliably detect and locate faults in low-fault microgrids.

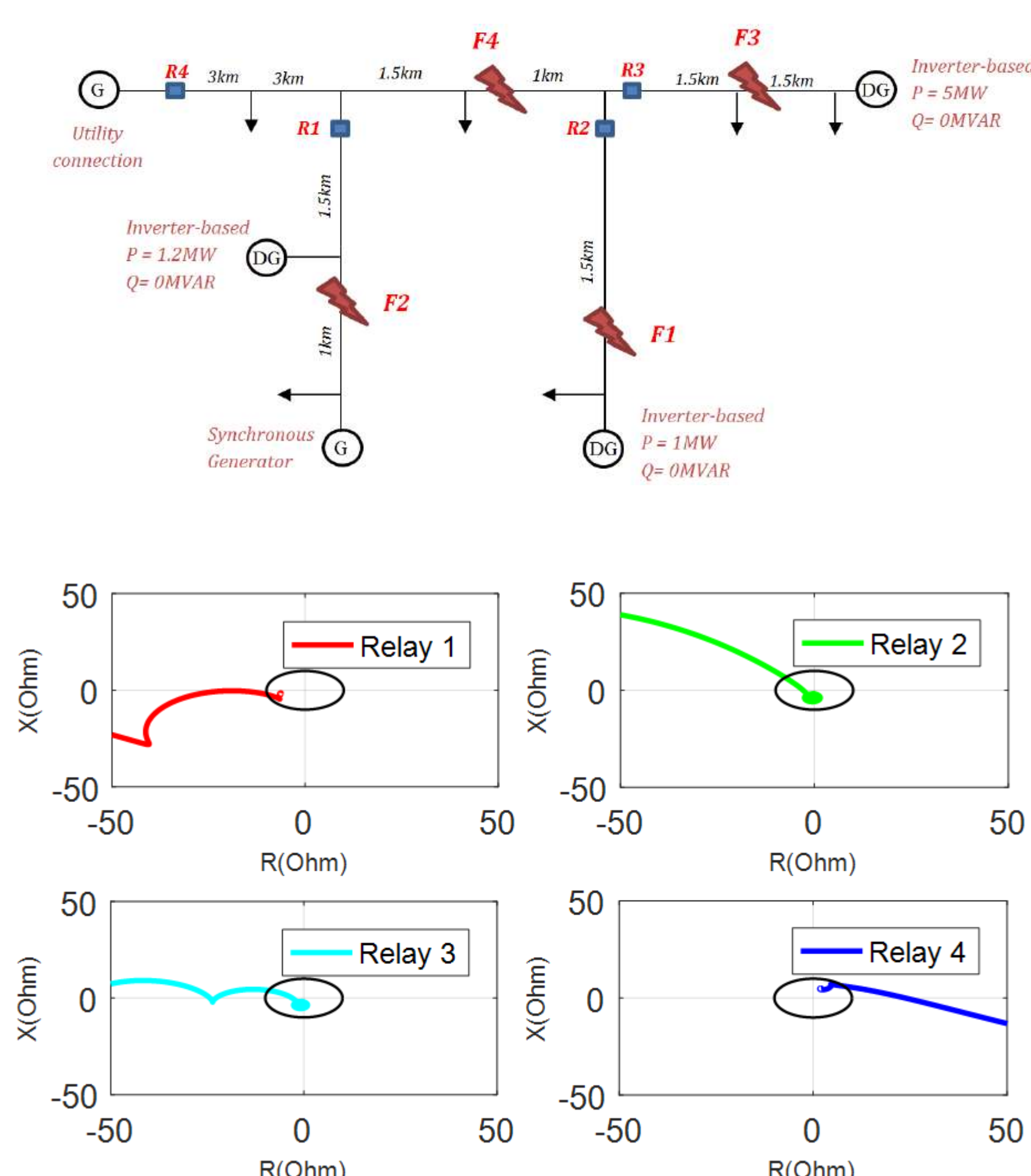

## Transients-based Protection

The effectiveness of transient-based fault detection relies on the transient signature. Detection of single phase to ground faults and sensitivity to capacitor switching are some of the main challenges. A combination of transient-based, voltage-based and zero sequence protection was shown to provide effective protection for low-fault microgrids.

