

Exceptional service in the national interest

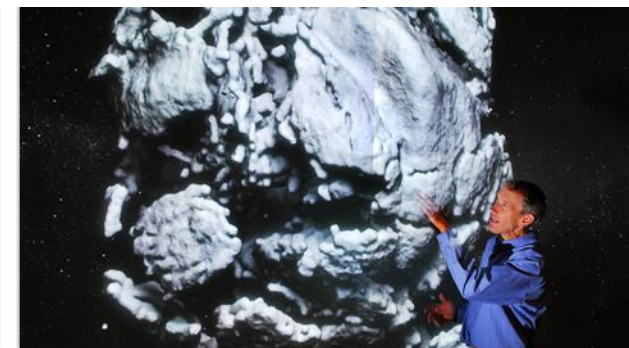

energy.sandia.gov

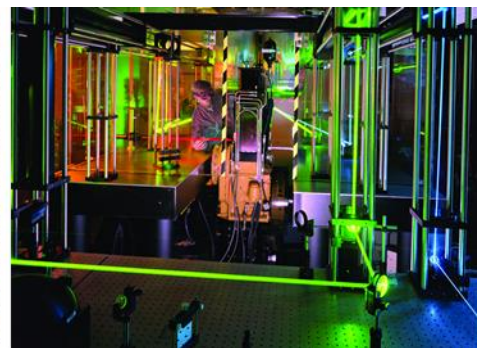

Progress & Challenges in Transitioning the US to a Renewable Energy-Focused Electrical Grid

University of New Mexico, 29 Sept 2016

Jay Johnson

Photovoltaic and Distributed Systems Integration, Sandia National Laboratories

Outline

- **What is Solar Energy?**
- **Status update:** We have made a lot of progress in the last decade, but there's still a long way to go.
- **Motivation** for adding renewables to the power grid:
 - combat climate change
 - cost-competitive in much of the US and world now
 - adds new jobs and reduces our dependence on foreign oil
- **Problem:** What are the roadblocks with this transition?
 - Bulk (transmission) system issues
 - Local (distribution) system issues
- **Solutions:** What can be done to solve these new challenges?
 - Advanced PV and energy storage systems are big help!
 - New communications, control, and optimization are critical

What is Solar Energy

- Typical Photovoltaic (PV) Residential Installation

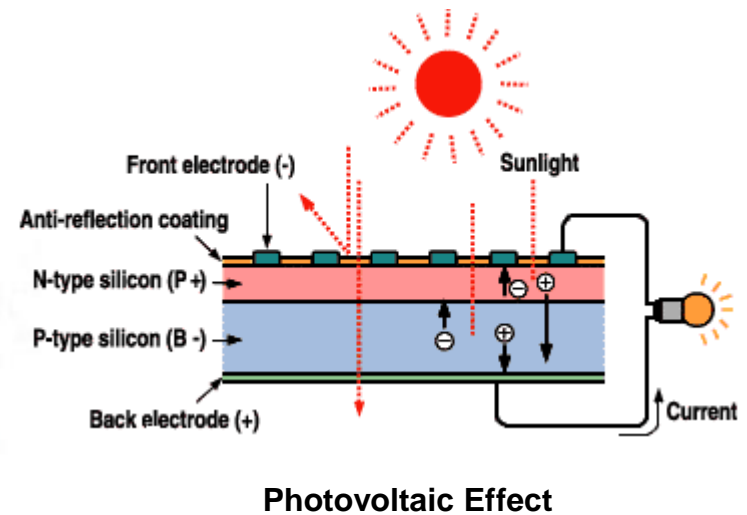
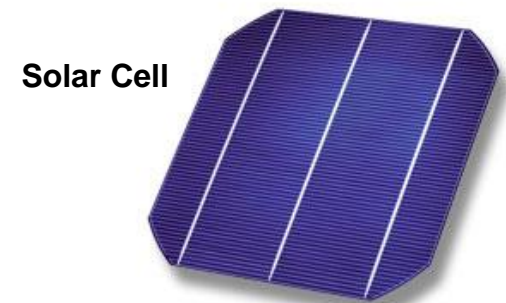

Typical Residential Solar Installation

Photovoltaic Cells, Modules, and Arrays

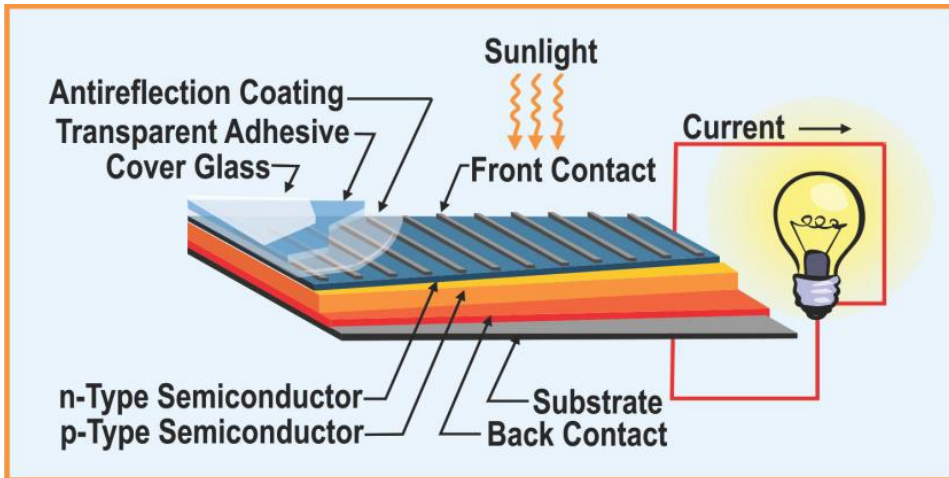
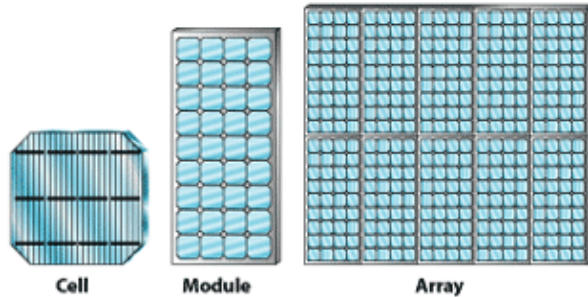

<http://www1.eere.energy.gov/solar>

Current-Voltage & Power-Voltage Curve (190S-24)

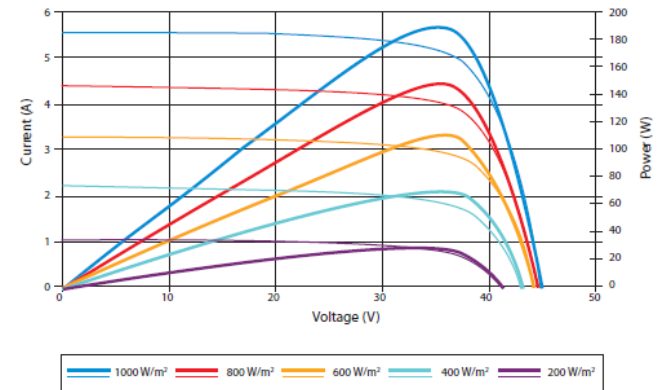

**Diode-like behavior of cells and modules:
higher current output at higher irradiance**

Courtesy SunTech PV

Utility-scale solar is large!



What are the installation trends?

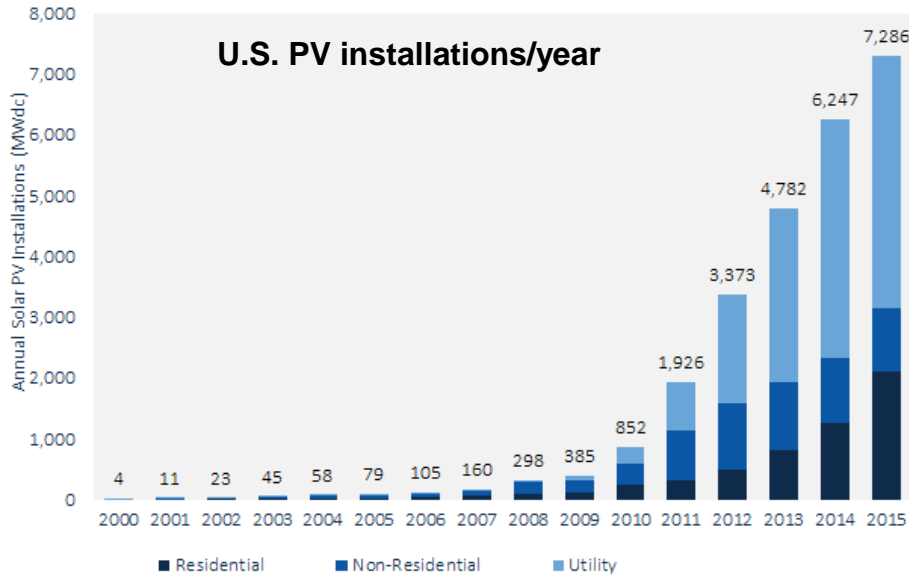

Cumulative installed solar PV globally

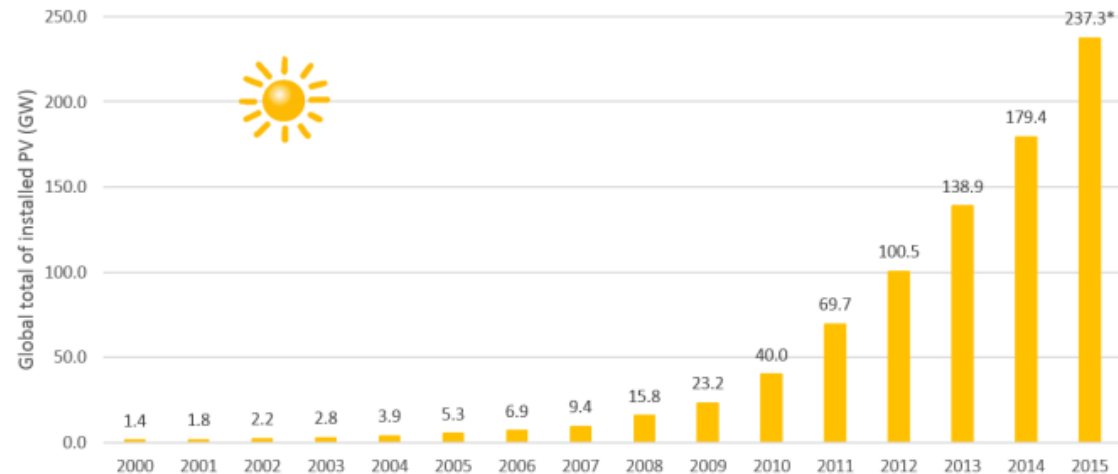

Why add renewables to the electrical grid?

Motivation #1: Climate Change



No human alive today has lived through a hotter month of August.

- You just lived through the hottest August on record! ...And July, and June, and May, and April, and March... It was *11th* Record-Breaking Month in a Row!
- Aug was 0.98°C above average across the planet, for records going back 136 years.

Hottest Month on Record

Temperature anomalies ($^{\circ}\text{F}$) each year since 1880

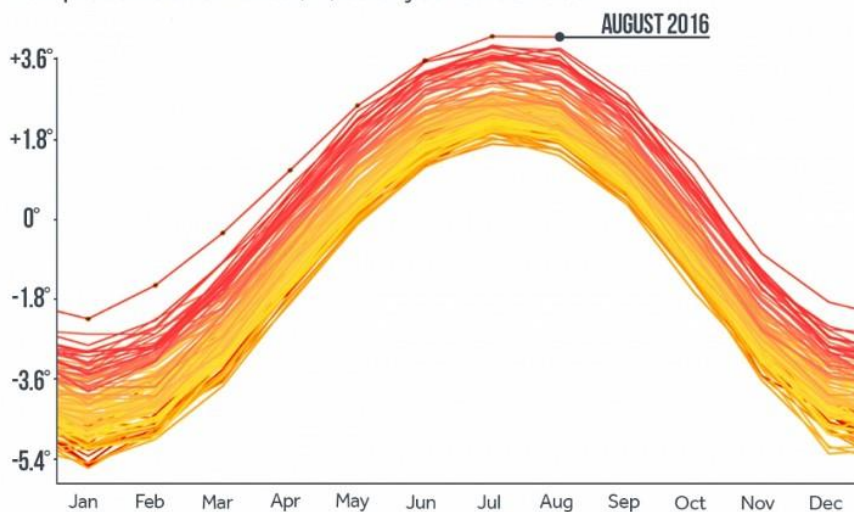

Curves adjusted for seasonal temperature cycle
Courtesy: Gavin Schmidt: NASA/GISS. Data as of August 2016.

CLIMATE CENTRAL

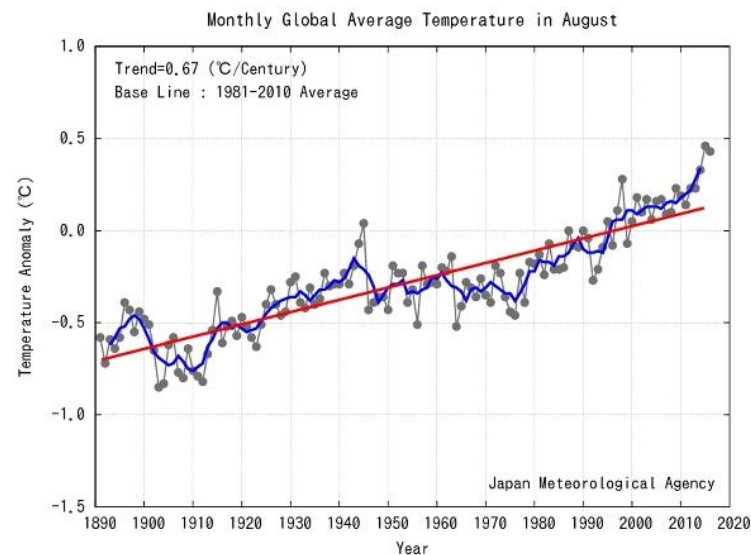

Anomalies are deviation from baseline (1981-2010 Average).
The black thin line indicates surface temperature anomaly of each year.
The blue line indicates their 5-year running mean.
The red line indicates the long-term linear trend.

**How many people here are
younger than 31?**

**...if you are, you have never
experienced a global monthly
temperature below average.**

Increasing temperatures are causing more natural disasters



Natural catastrophes worldwide 1980 – 2011
Number of events with trend

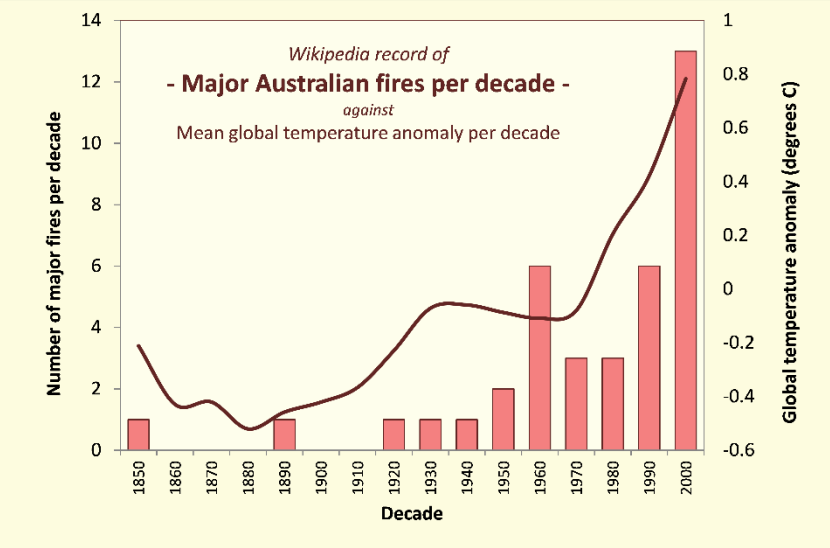
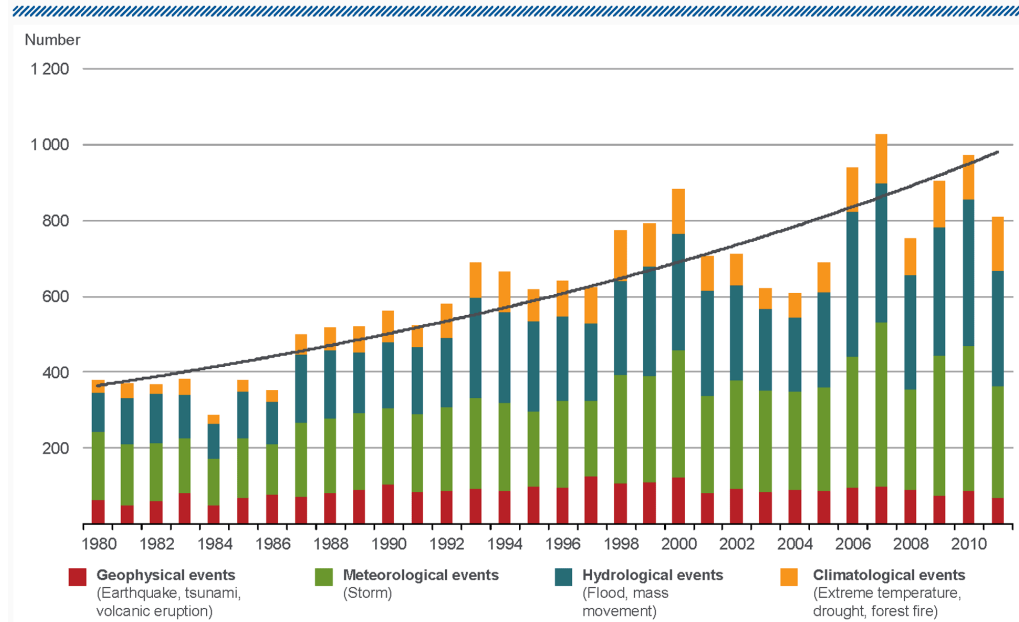

More Large Wildfires in the West

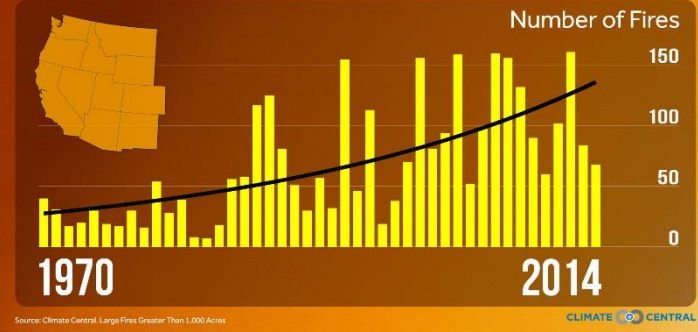

Why add renewables to the electrical grid?

Motivation #2: It's cheap and getting cheaper!

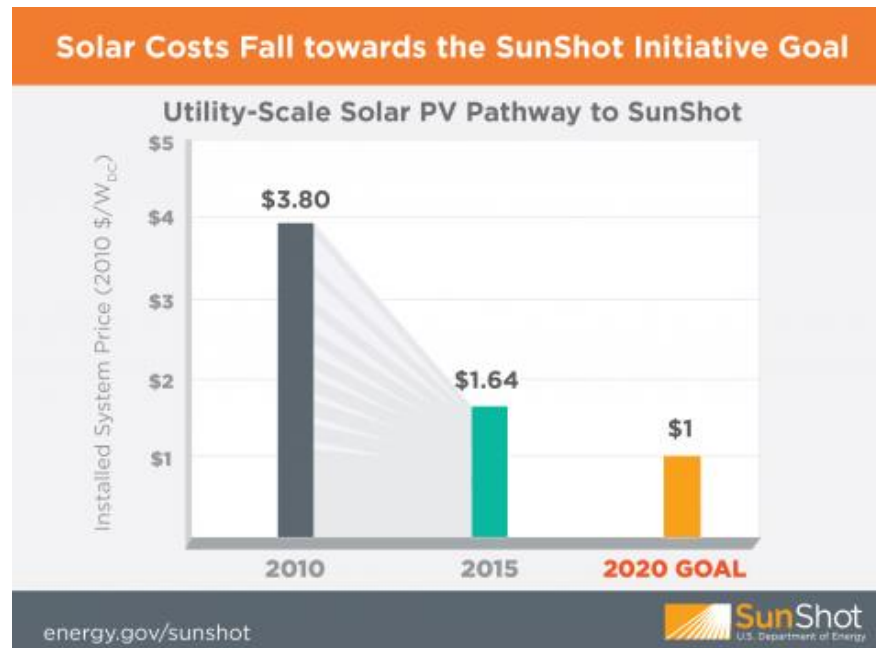

The **DOE SunShot Initiative** aims to reduce the total installed cost of solar energy systems to \$0.06 per kilowatt-hour (kWh) by 2020. Today, SunShot is about 70% of its way toward achieving the program's goal, halfway into the program's ten-year timeline.

Lower prices = more solar installations

AS SOLAR MODULE COSTS DECLINE, ANNUAL INSTALLATIONS RISE

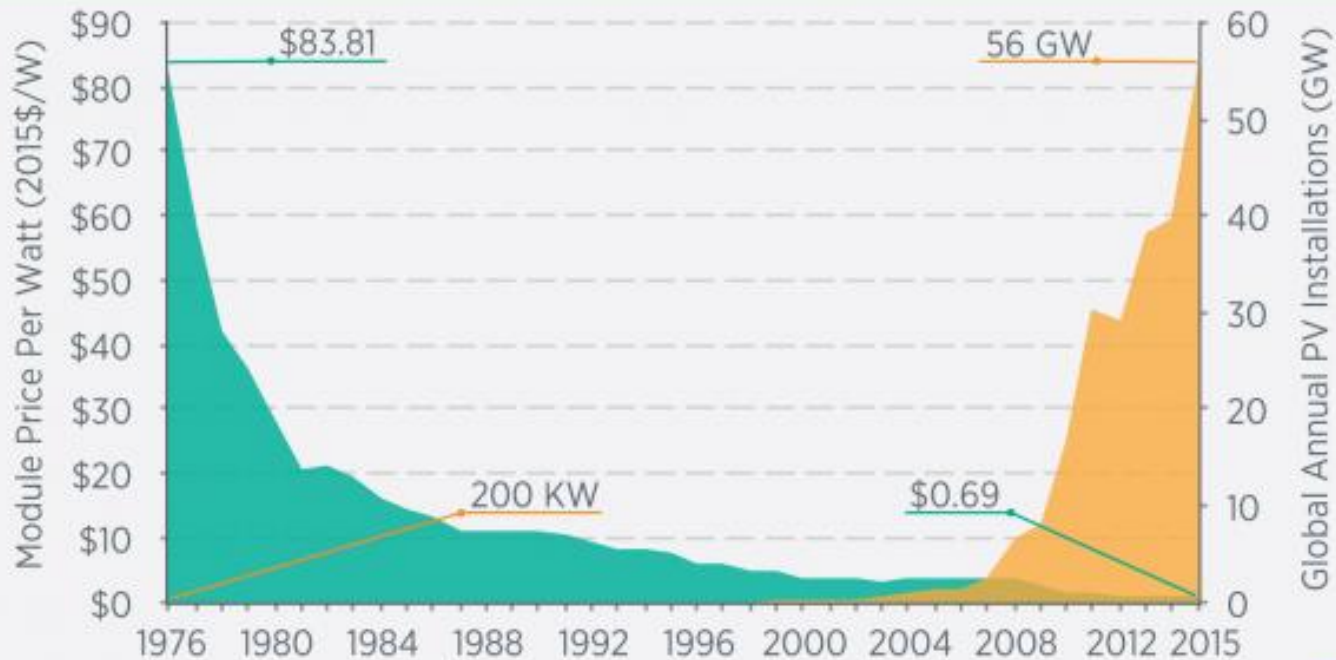

LCOE Energy Comparison

Unsubsidized Levelized Cost of Energy Comparison

Certain Alternative Energy generation technologies are cost-competitive with conventional generation technologies under some scenarios; such observation does not take into account potential social and environmental externalities (e.g., social costs of distributed generation, environmental consequences of certain conventional generation technologies, etc.) or reliability-related considerations (e.g., transmission and back-up generation costs associated with certain Alternative Energy technologies)

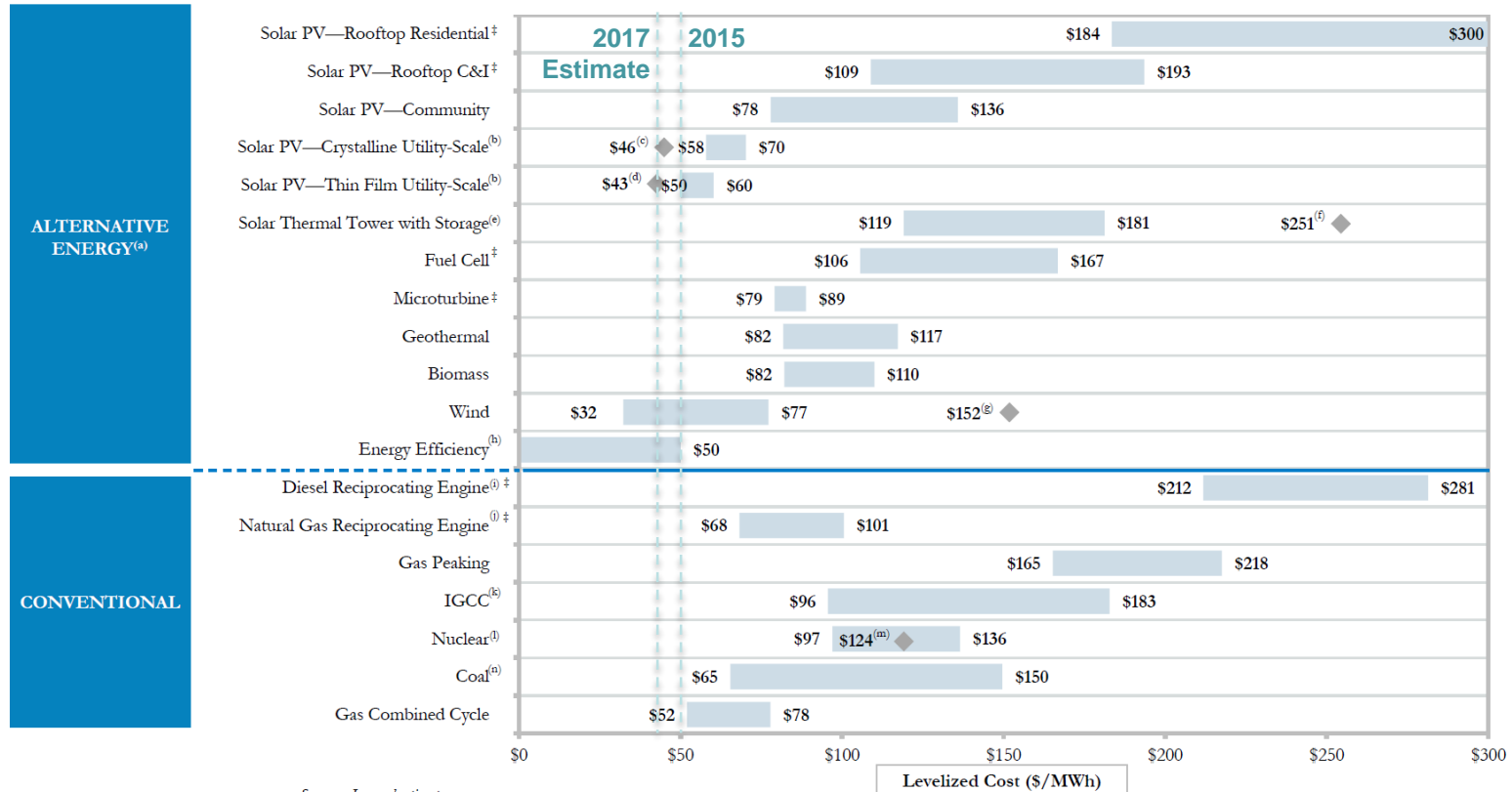

Source: Lazard estimates.

Note: Here and throughout this presentation, unless otherwise indicated, analysis assumes 60% debt at 8% interest rate and 40% equity at 12% cost for both conventional and Alternative Energy generation technologies. Assumes diesel price of ~\$2.50 per gallon, Northern Appalachian bituminous coal price of ~\$2.00 per MMBtu and a natural gas price of ~\$3.50 per MMBtu for all applicable technologies other than Natural Gas Reciprocating Engine, which assumes ~\$5.50 per MMBtu. Analysis does not reflect potential impact of evolving regulations/rules promulgated pursuant to the EPA's Clean Power Plan. See following page for footnotes.

Solar delivering cheapest electricity ever, by any technology

- Chile has just contracted for the cheapest unsubsidized power plant in the world: 2.91 cents per kilowatt-hour
 - ½ the price of coal!
 - Average residential price for electricity in the US is 12 cents/kWh



August 18, 2016: “One of the contracts was the cheapest deal ever seen for any type of power project, according to Bloomberg New Energy Finance. The Spanish solar-energy developer Solarpack Corp. Tecnologica won a contract to sell power from a 120 megawatt-solar plant for \$29.1 per megawatt-hour”

<http://www.bloomberg.com>

Why add renewables to the electrical grid?

Motivation #3: Jobs

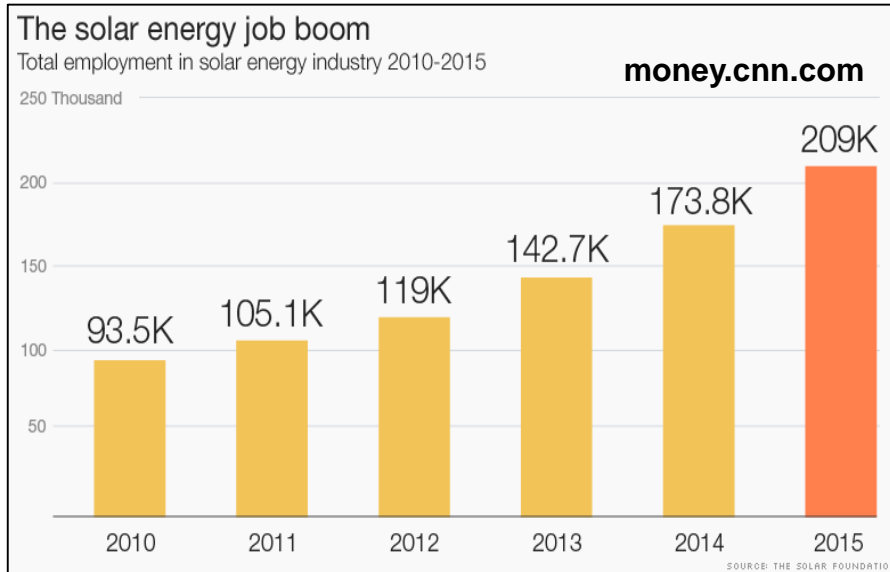

As of 2012, there were more solar jobs than coal jobs in the US!

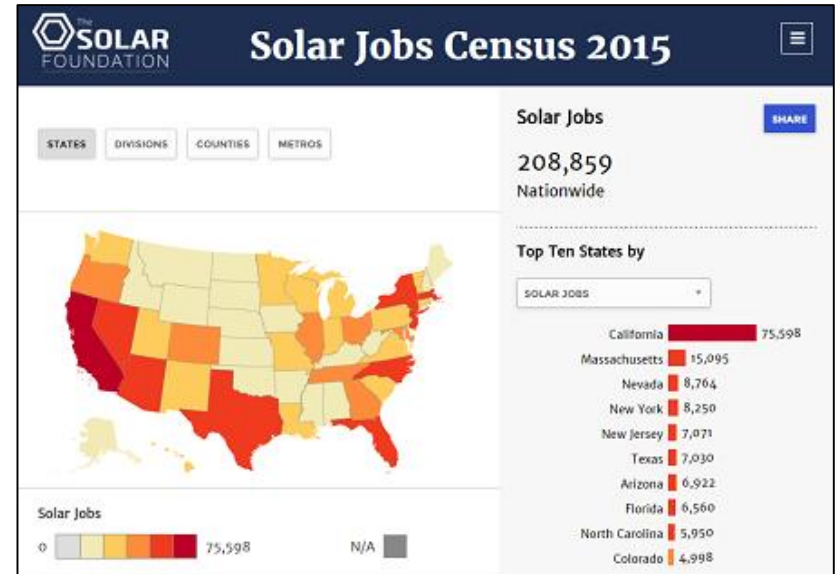
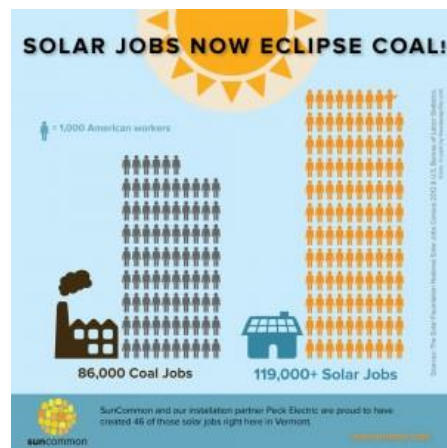

Interactive map: <http://solarstates.org/#states/jobs>

Solar Energy Fun Facts

- More energy from sunlight strikes the Earth in one hour than all the energy consumed on the planet in one year (13 Terawatts).
- Solar energy is a carbon- and water-free energy source
- Solar cells are Silicon, a plentiful resource

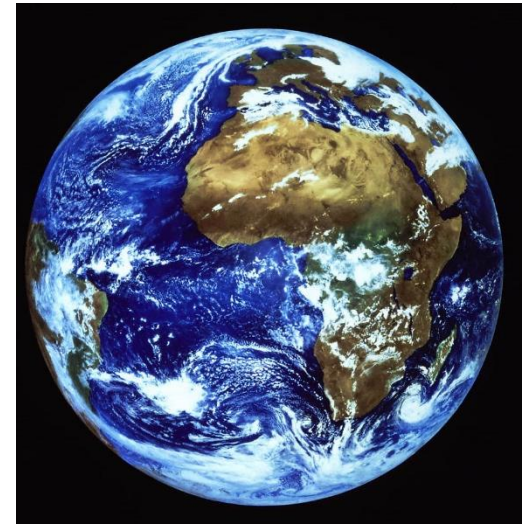

Solar energy is the only long-term option capable of meeting the energy (electricity and transportation fuel) needs of our planet.

Solar = 7,500 TW

Wind = 14 TW

Geothermal = 2 TW

Hydro = 1 TW

Ocean = 0.6 TW

Source: Estimated Extractable Resource (DOE-OS-BES)

Power Systems 101

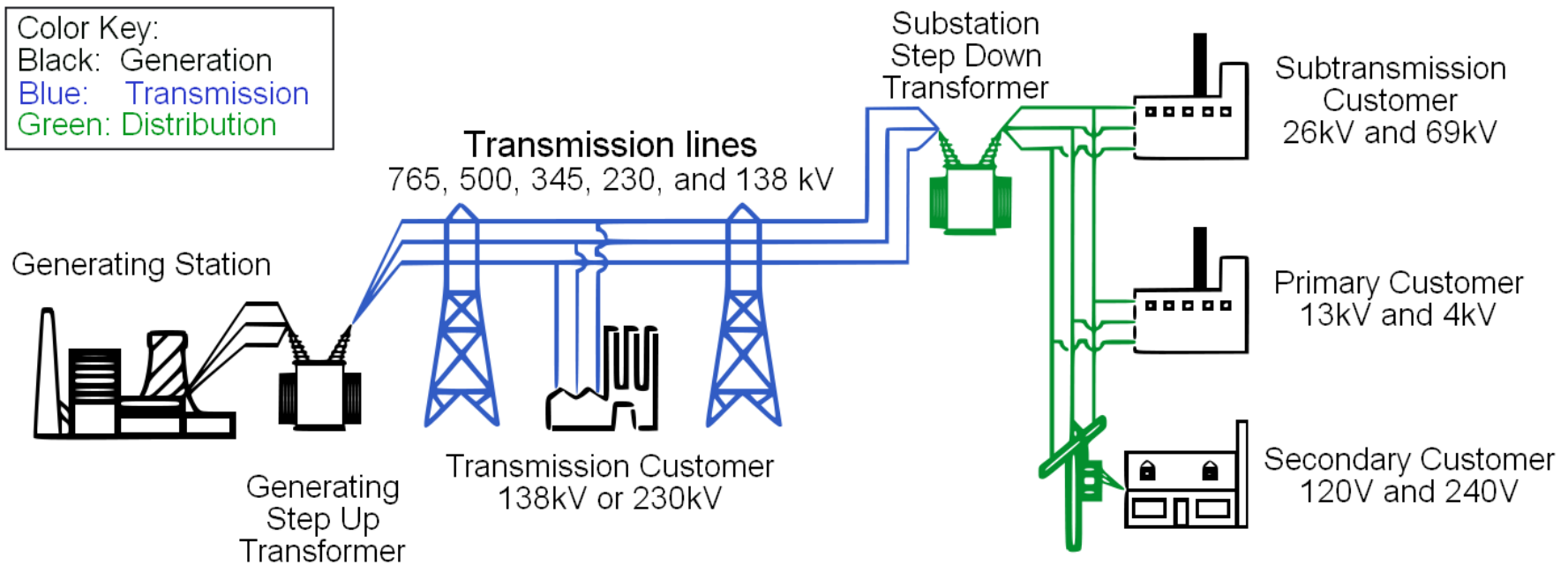

Power Systems

■ Transmission

- EHV: 345, 500, 765 kV
- HV: 115, 138, 230 kV
- Typically networked
- Long-distance
- DC lines are used, too

■ Sub-Transmission

- 46, 69 kV
- Network or long radial (e.g., rural feeders)

■ Distribution

- 4.16, 12.47 kV
- Radial
- Urban feeders

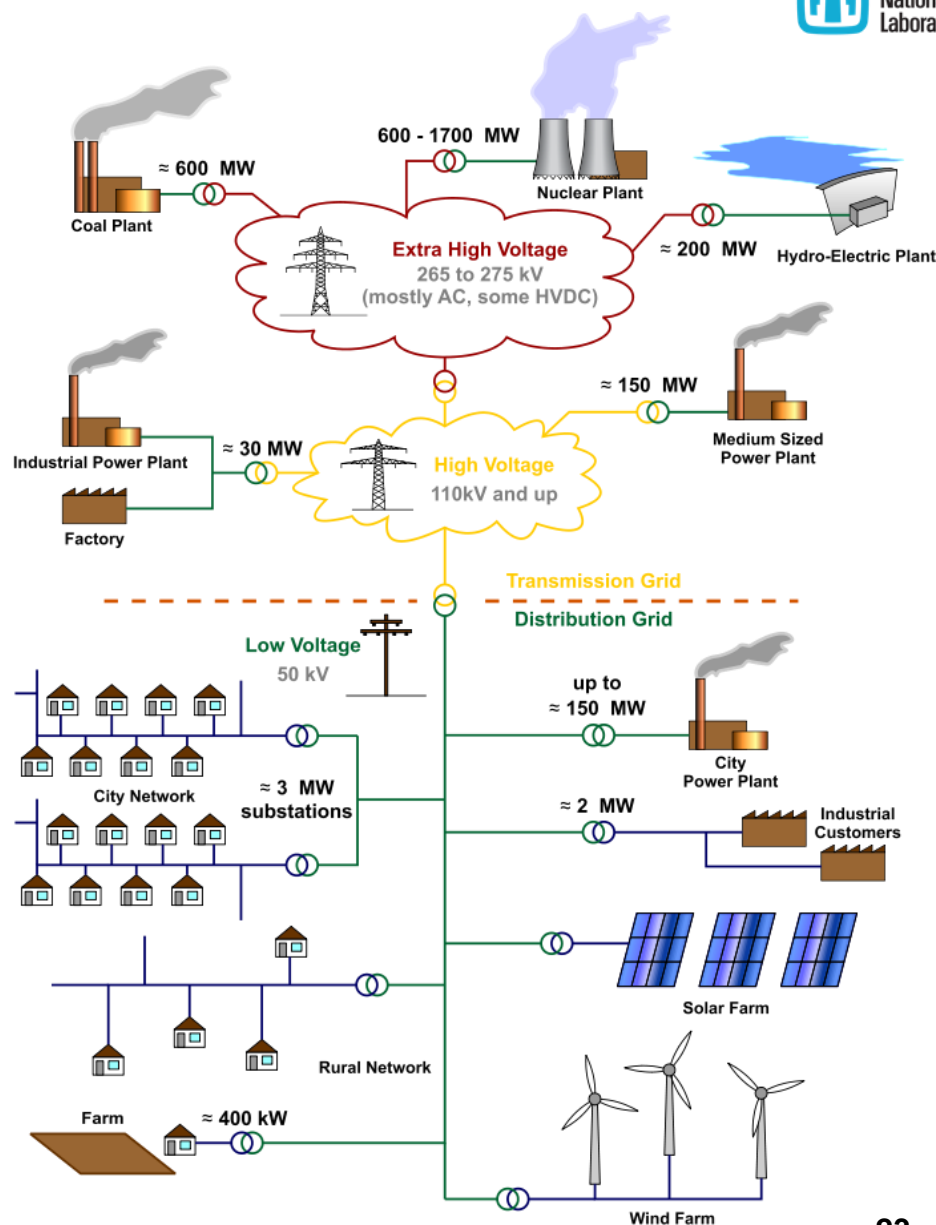

Grid performance requirements

- Voltage & frequency control
- Protection
 - How to tell when/where there is a problem (e.g., fault)
 - Ensure safety, prevent damage to equipment, avoid cascading
- System stability
 - How voltage and frequency recover from a disturbance
- Continuity of service
 - Benchmark: 1-day cumulative outage per customer in a 10-year span (99.97% reliable)

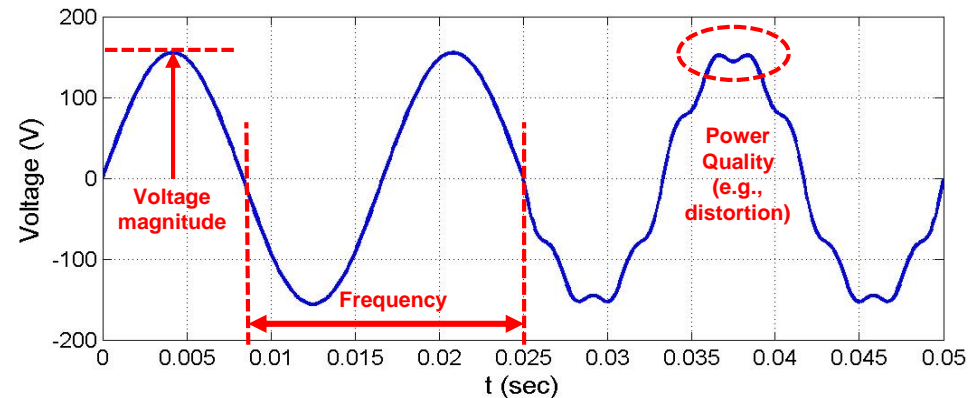

Frequency and Voltage Control

- For this presentation, let's talk about two basic grid needs:

1. Frequency control

- Balancing generation and load (power consumption)
- Control necessary at the transmission (bulk) system
- The prevents blackouts and brownouts

2. Voltage regulation

- Holds the voltage to safe levels for equipment, e.g., computers
- Control mostly challenging at the distribution level

Laptop on fire
(probably not from overvoltage event)



New York skyline, blackout of 2003.

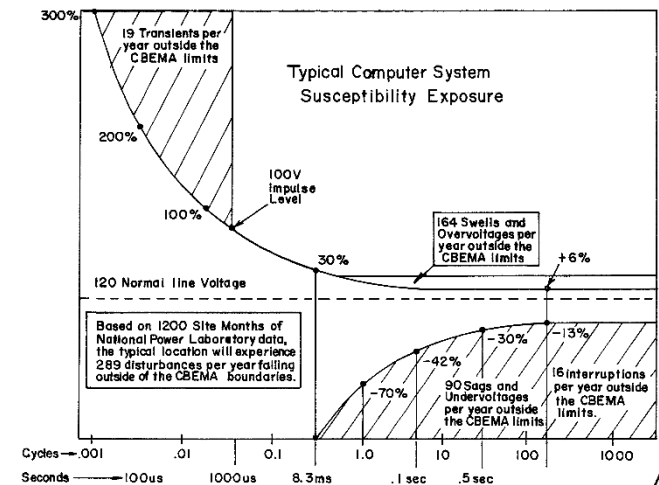

Computer and Business Equipment Manufacturers' Association (CBEMA) curve.

NERC (North American Electric Reliability Corporation) Regions

NERC: North America Electricity Reliability Corporation

FRCC: Florida Reliability Coordinating Council

MRO: Midwest Reliability Organization

NPCC: Northeast Power Coordinating Council

RFC: Reliability First Corporation

SERC: SERC Reliability Corporation

SPP: Southwest Power Pool

TRE: Texas Reliability Entity

WECC: Western Electricity Coordinating Council

NERC INTERCONNECTIONS

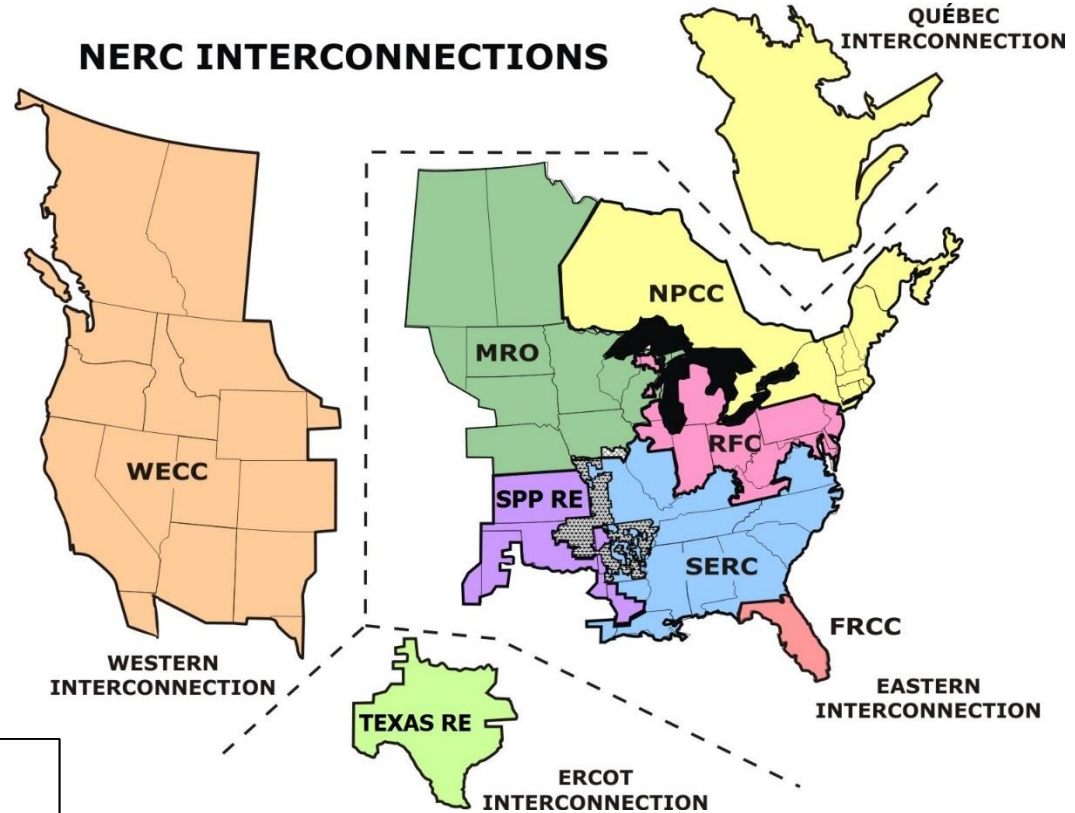

Net Demand (MW) – Summer 2008

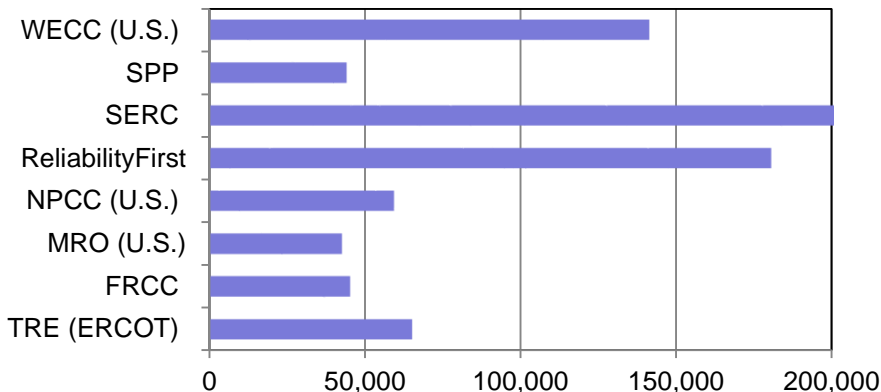

Contiguous US: 780,068 MW
Capacity Resources: 929,338 MW
Source: NERC

Bulk System Operations

- Regulation, Load Following, and Scheduling balance power at different time-scales.

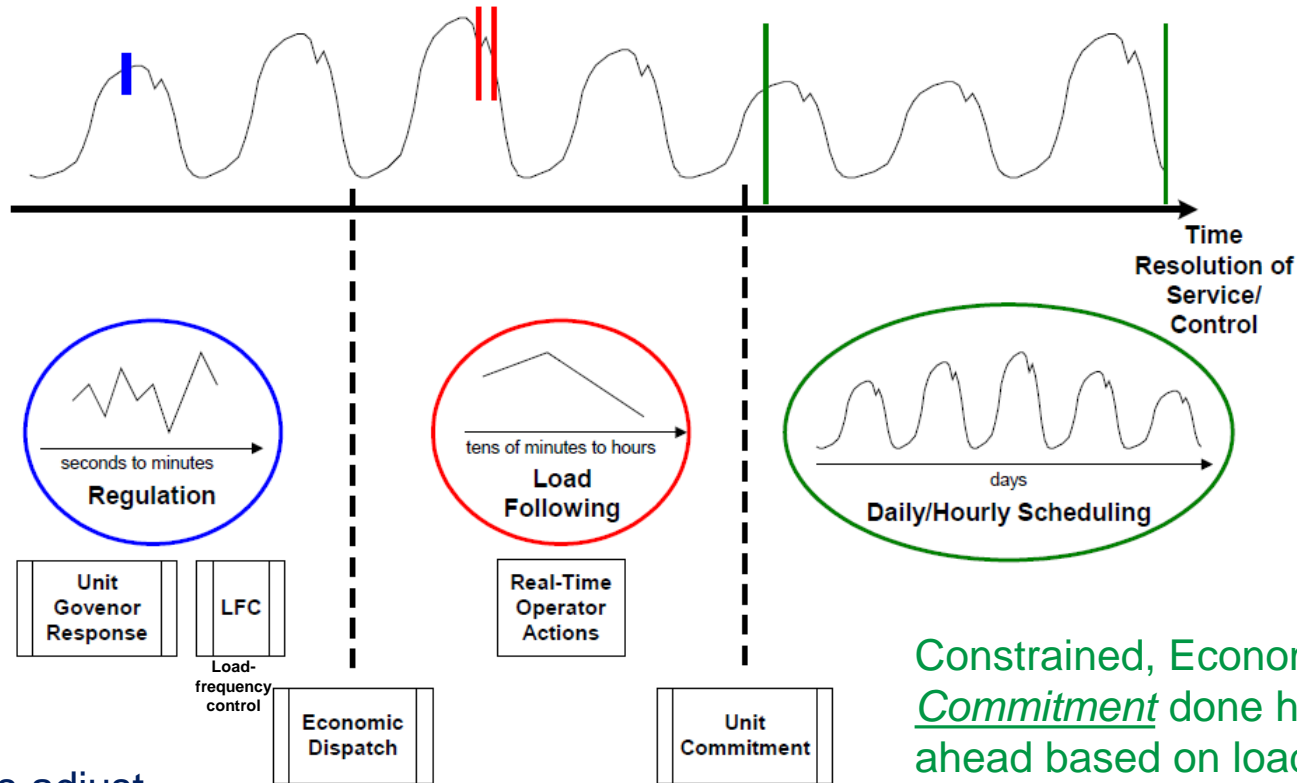

Generators adjust output automatically in response to phenomena faster than operators have time to react.

Operators dispatch units based on actual system needs.

Constrained, Economic Unit Commitment done hours to days ahead based on load/generation forecast and generator characteristics (e.g., ramp rates).

Reserves also committed to cover uncertainty.

PV causes challenges for bulk system balancing

- Issue #1: Solar power production is variable!

Global Horizontal Irradiance in 2010

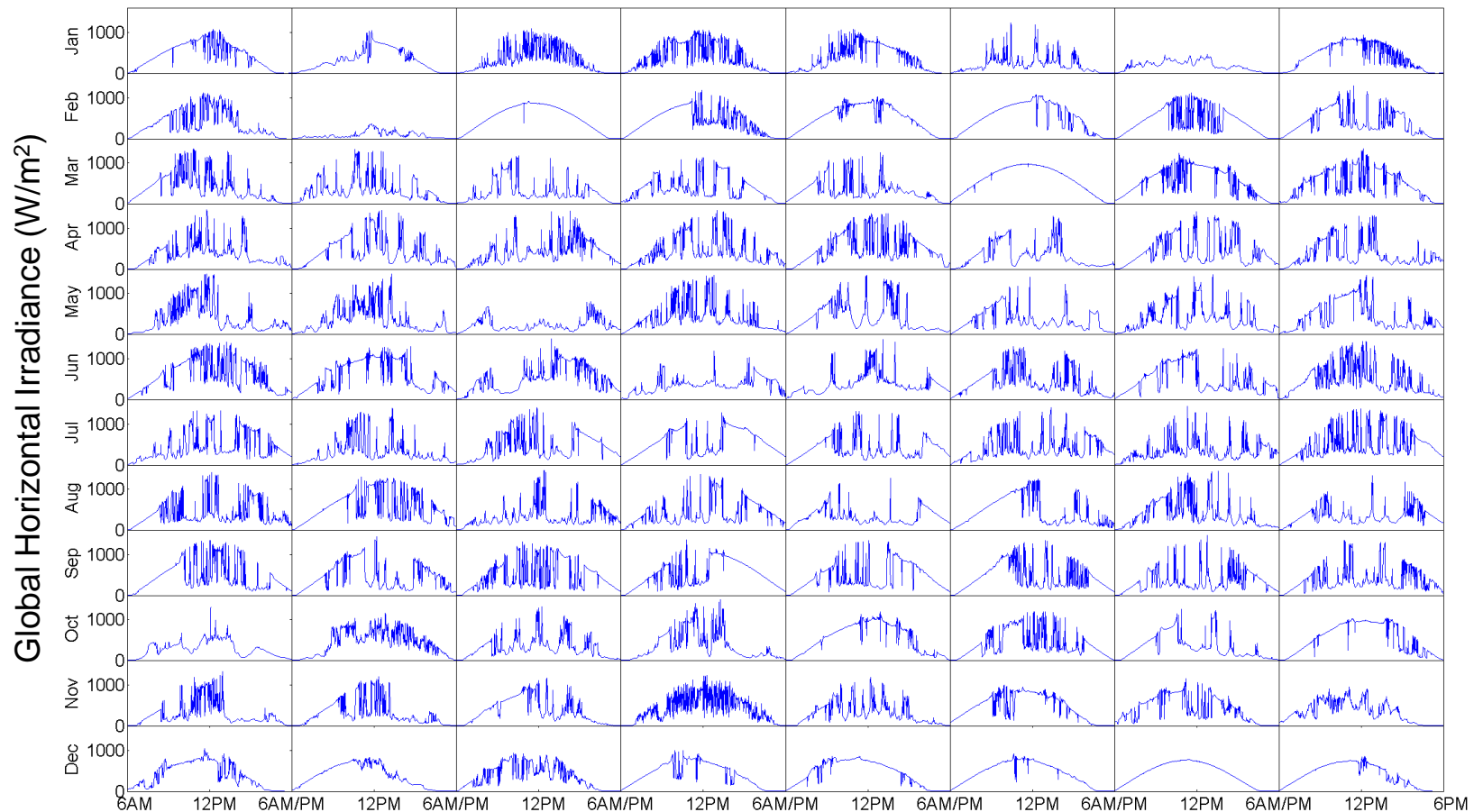

PV causes challenges for bulk system balancing.

- Issue #2: PV displaces generator inertia and causes larger frequency variations.
 - Especially when a generator faults on the power system.

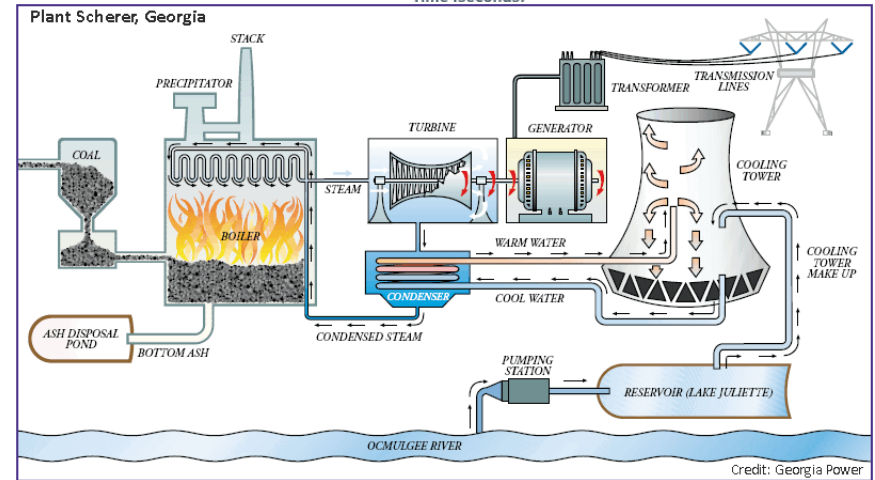
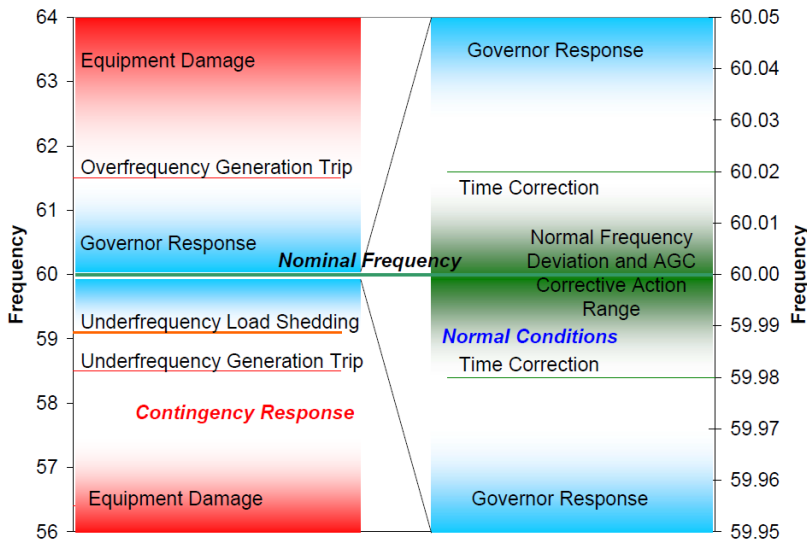
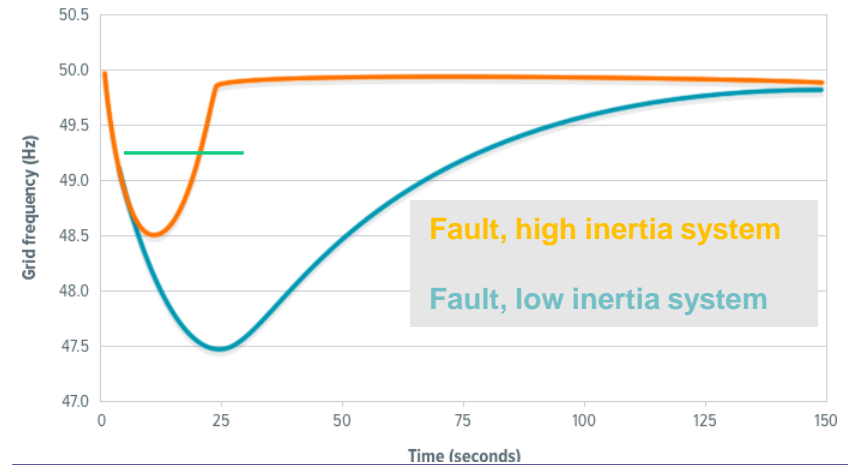
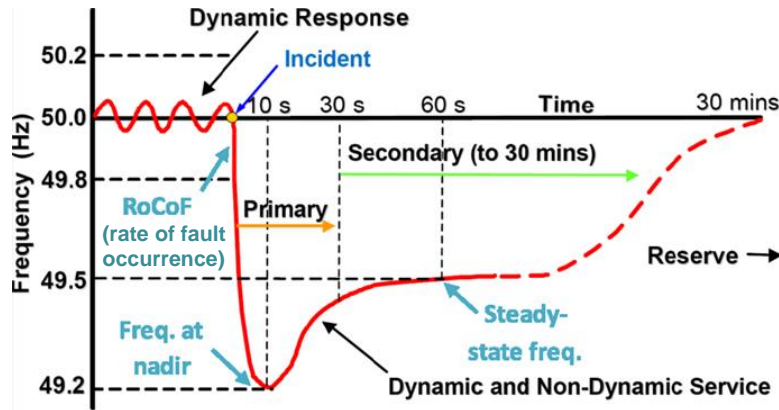

Coal-Fired Thermoelectric Power Plant 31

Distribution System Components

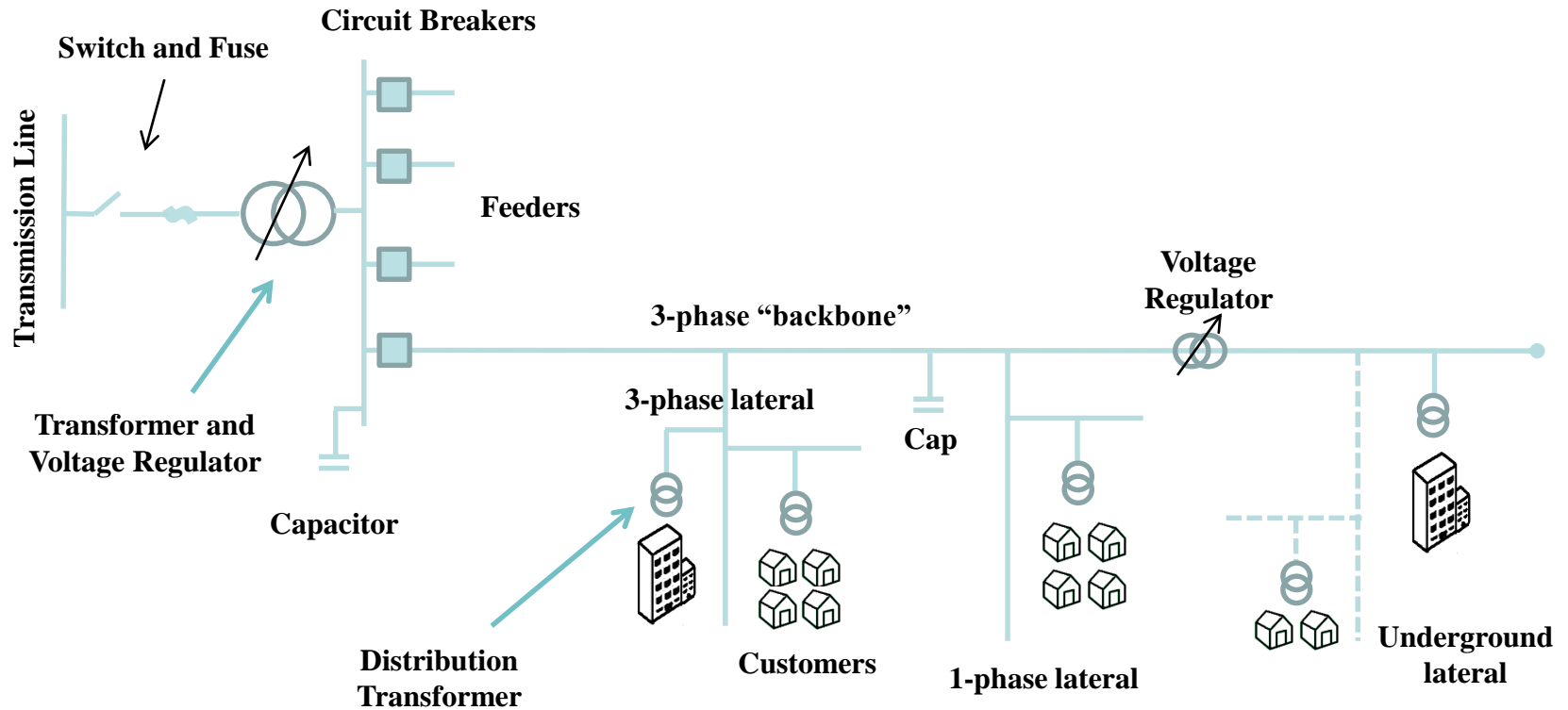

Distribution System Voltages (more detail)

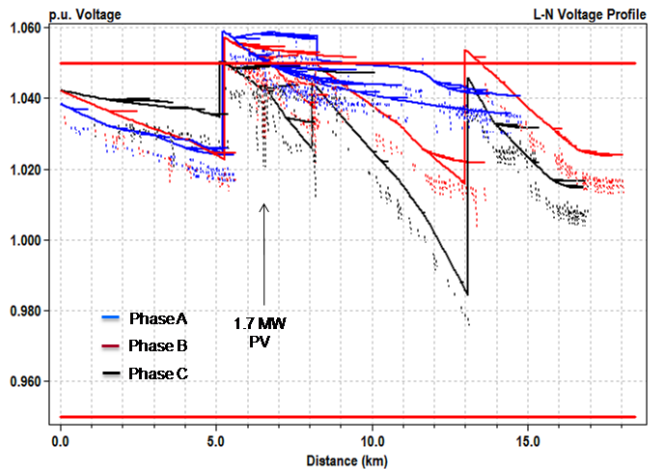

- Distribution network voltages change along the power line.
- Must be maintained within $\pm 5\%$ (ANSI C84.1)

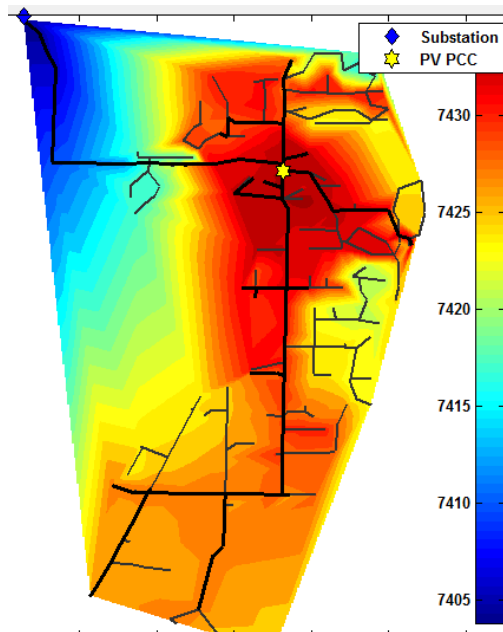
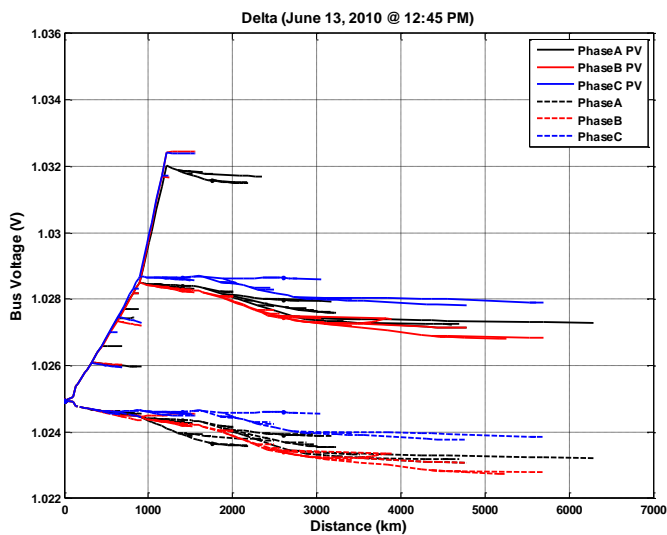

M. Reno, J. Quiroz, 2011

High-Pen PV and Grid Performance

- PV characteristics (variable, non-dispatchable, inverter-based, distributed) can affect grid performance
 - Local voltage control & protection issues tend to emerge first

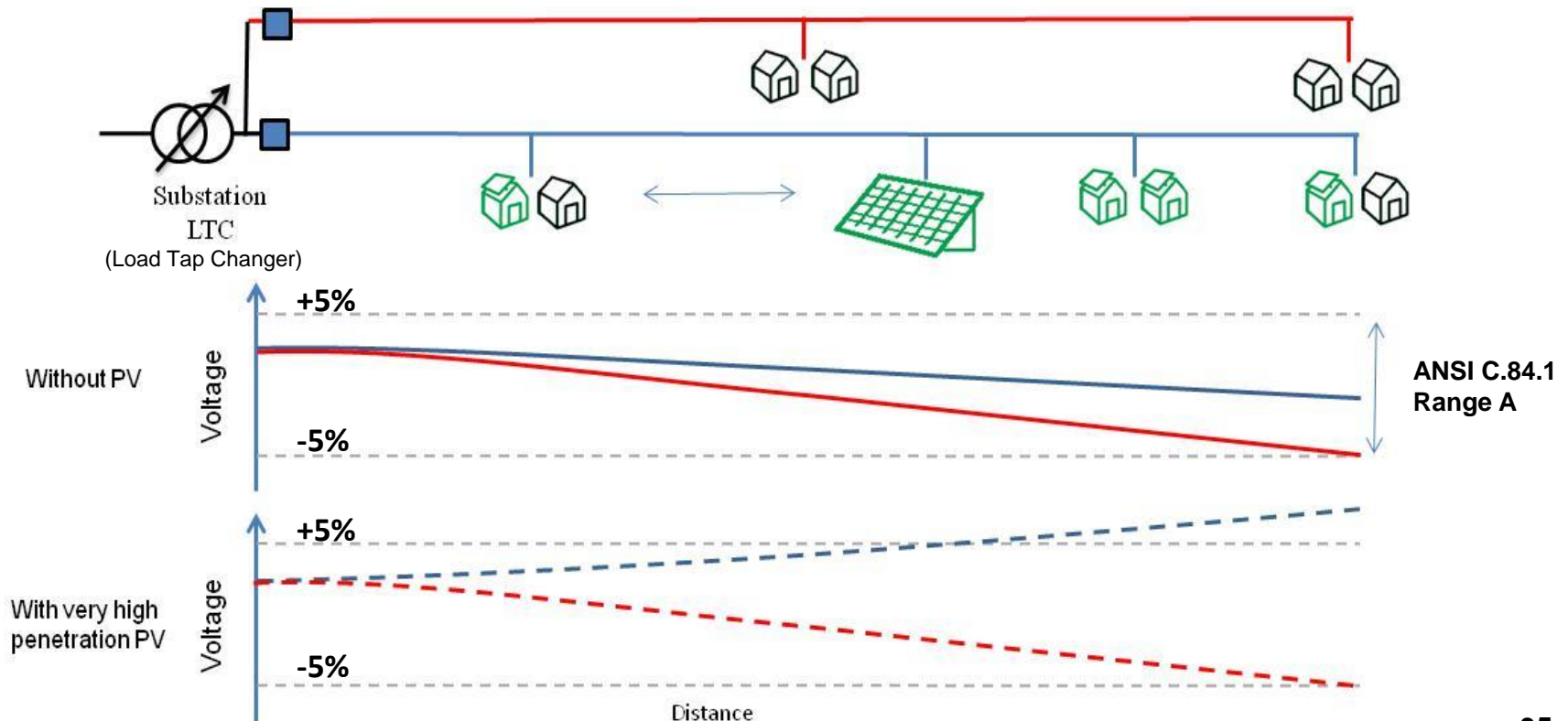

High-Pen PV and grid performance

- One example protection issue:
 - A fault on the distribution circuit will have a given impedance to ground.
 - Ohm's law: there will be an associated fault current for given feeder voltage.
 - If the fault current is sourced by PV, the circuit breaker will not see an increase in feeder current and won't trip (when it should).

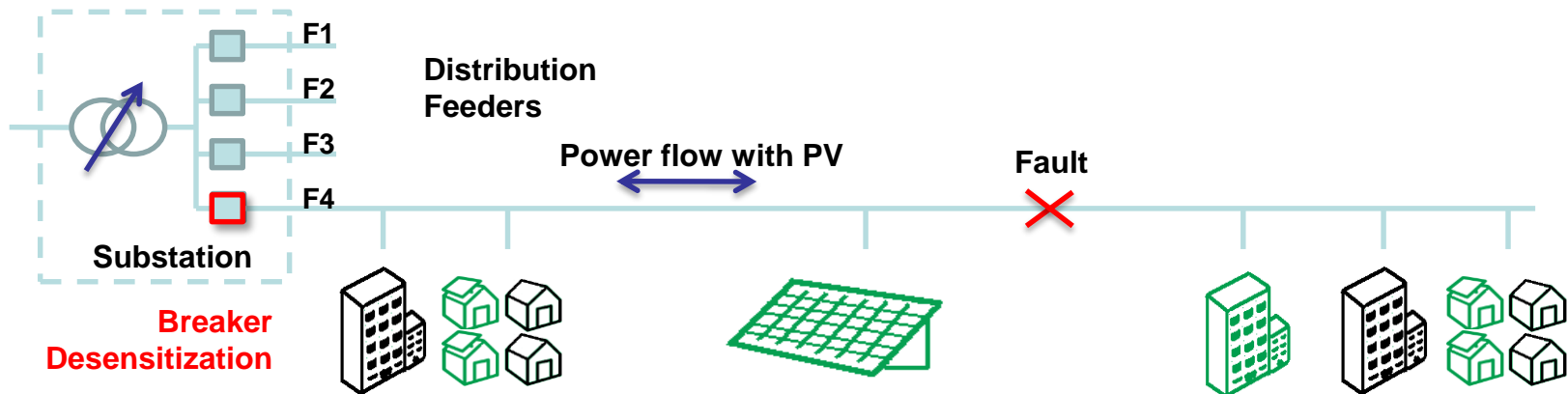

Solar Problems Manifest!

- **Hawaii installs a lot of PV** because electricity prices in HI are \$0.34 kWh!
 - Most of the power is from shipped crude oil
 - PV payback periods are ~5 years
- **Protection issues** caused the Hawaii Public Utility Commission **formally cap** new **PV customers** in Sept 2013:
 - No PV if nameplate generation is >100% of daytime minimum load (DML) on the distribution circuit.
 - Stated issue of **reverse power flows** would **prevent substation protection from operating** correctly. (For cost reasons, many of the circuit overcurrent protection and power voltage regulation devices are designed with the assumption that power flows in one direction.)
 - Actual problem from **transient overvoltage** when feeder is isolated at a time when generation > load.
- By Sept 2016 **bulk system limits** were hit on the Big Island (5 MW), Maui (5 MW) and Oahu (25 MW)
 - New fear: not enough inertia/contingency reserves to prevent blackout in an N-1 (generator fault) situation.
 - New installations must be “self-consumption” systems with a battery (solar energy is stored and used only at the house)

If you don't install solar in HI, you aren't very good at math.

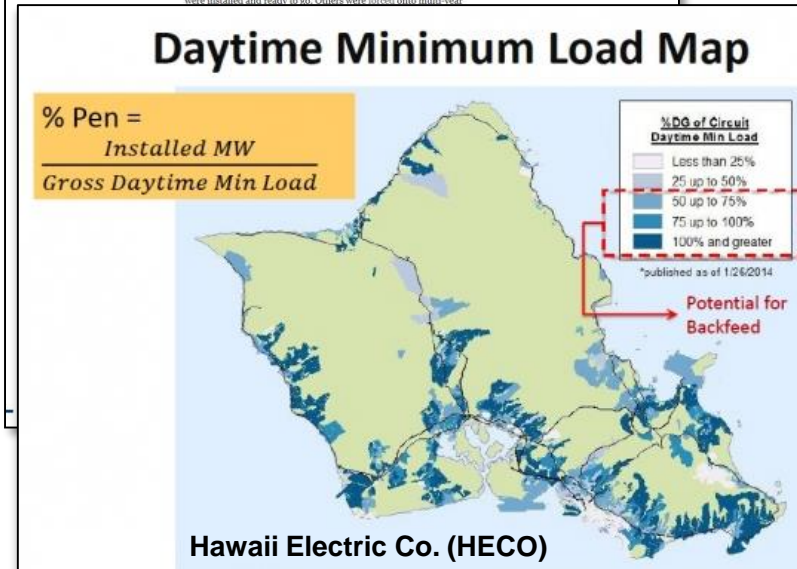
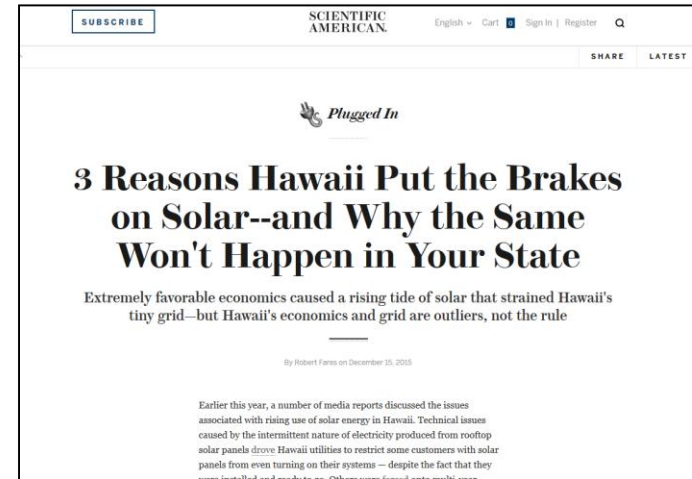

CA “duck” curve. Do you see a Duck?

- Ramp rate problem:
 - Solar is changing the ramping requirements for generators. This is difficult for base load generators.

CAISO Net Load Projections

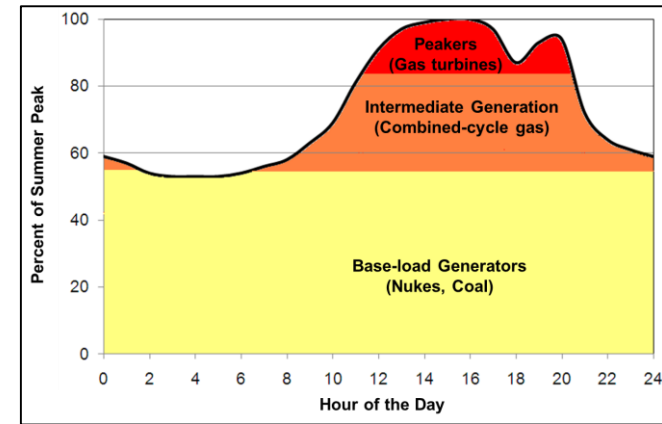
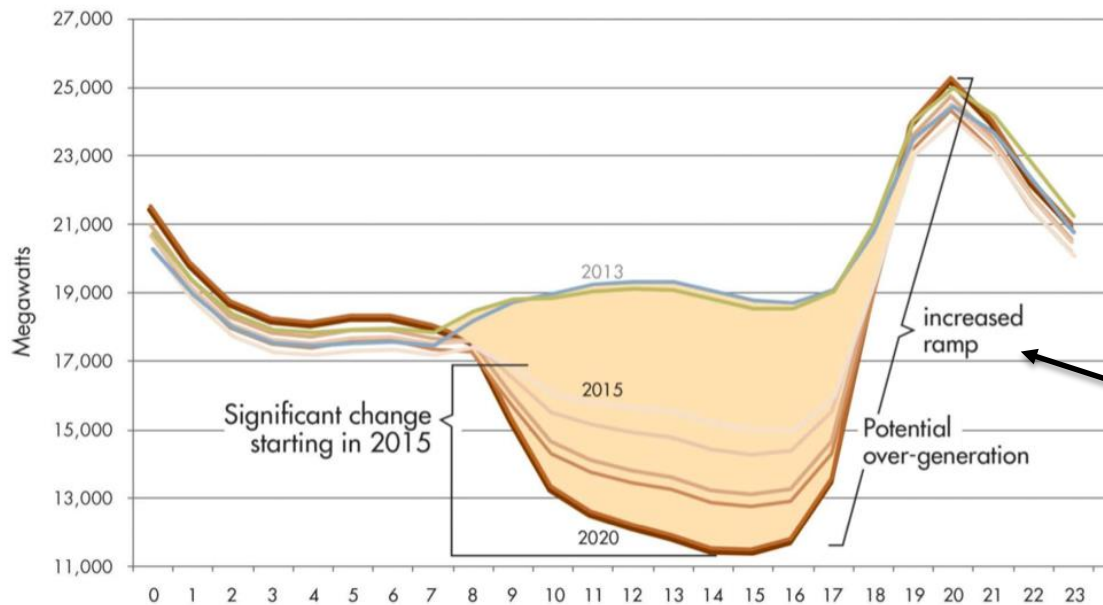

**CAISO needs
~13,000 MW in
3 hours**

CA “duck” curve. Do you see a Duck?

- Ramp rate problem:
 - Solar is changing the ramping requirements for generators. This is difficult for base load generators.

CAISO Net Load Projections

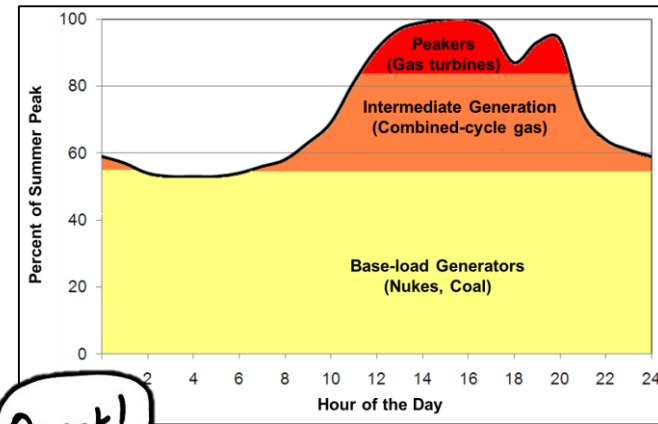
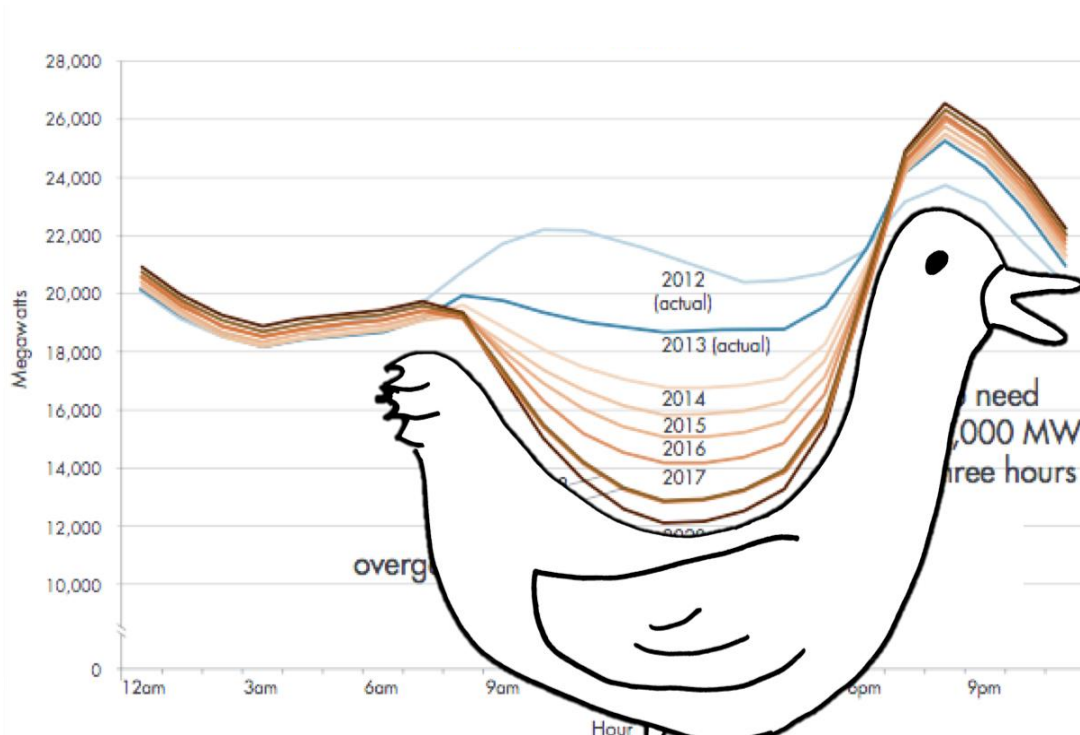

Quack!

**CAISO needs
~13,000 MW in
3 hours**

Save Us Smart Inverters!

- It will become increasingly difficult and expensive to integrate high-pen PV
- A big part of the solution: deployment of advanced inverters
 - Mitigate high-pen impacts and enhance value of PV to owner and grid
- Advanced inverters definition...
 - Actively support voltage and frequency by modulating output
 - Have high tolerance to grid disturbances
 - Interact with the system via communications

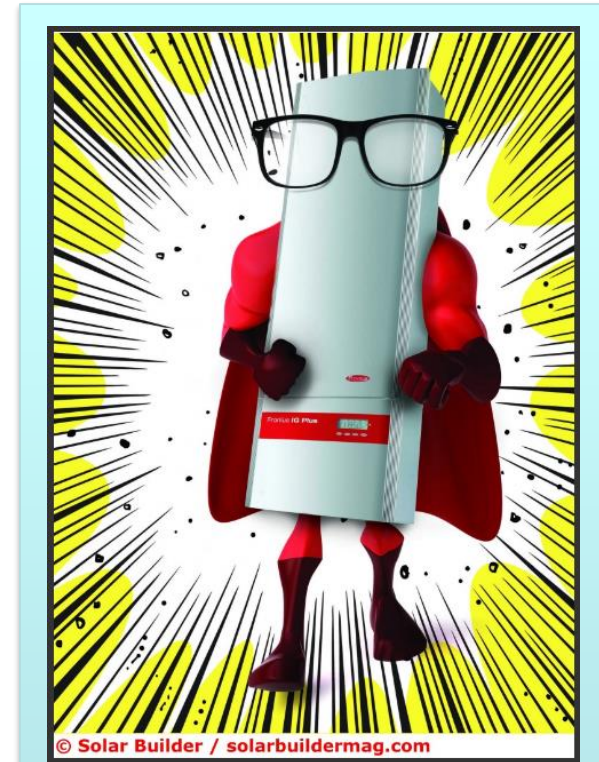

*...Faster than a tap changer
...More powerful than a
rotating machine
...Able to leap deep voltage
sags in a single bound*

Courtesy of B. Lydic, Fronius

Functional definitions

- Describe how the functions are implemented
 - Autonomous: Inverter response to local voltage and frequency conditions
 - Commanded: Remote control (e.g., on/off) & configure autonomous behavior

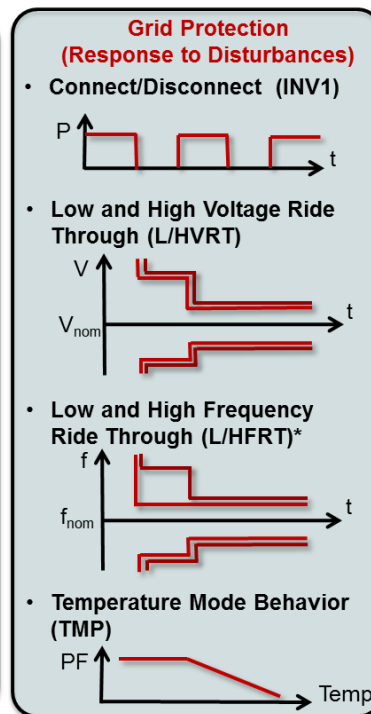
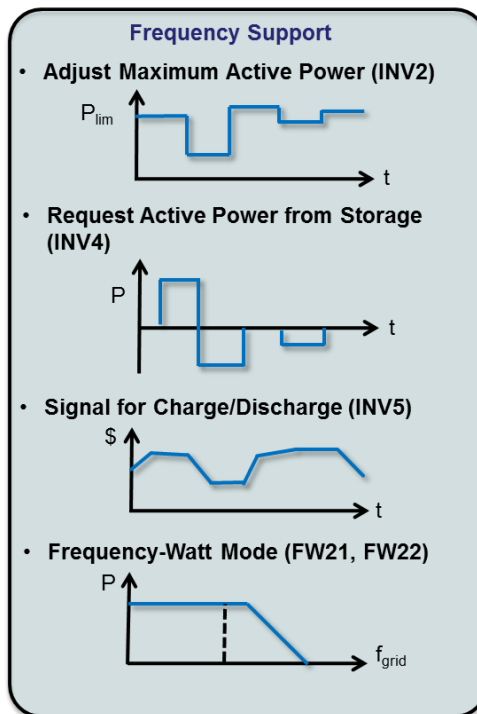
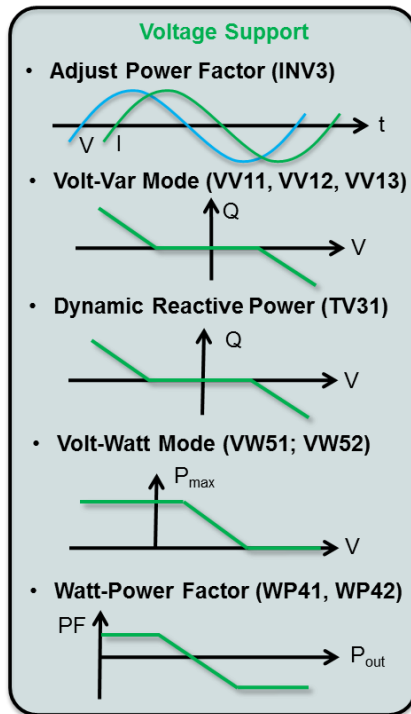

- In 2009, EPRI and Sandia initiated an effort to develop industry consensus on advanced inverter functions definitions, part of SEGIS effort
- Effort covers inverter-based DER (including PV and storage)
- The product became part of the IEC 61850-90-7 technical report

Advanced functions as defined in IEC TC 61850-90-7.

Advanced inverters provide voltage support to distribution circuits

- Advanced inverters allow for higher PV penetration
 - It has been shown that PV inverters with Volt/Var capability can double a distribution circuit's PV hosting capacity

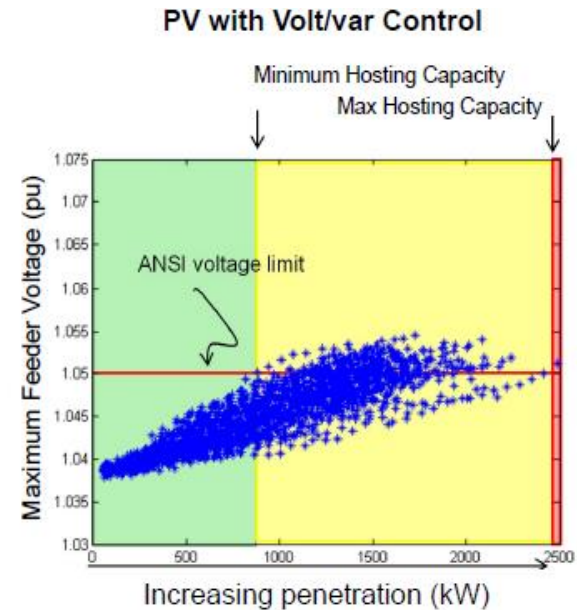
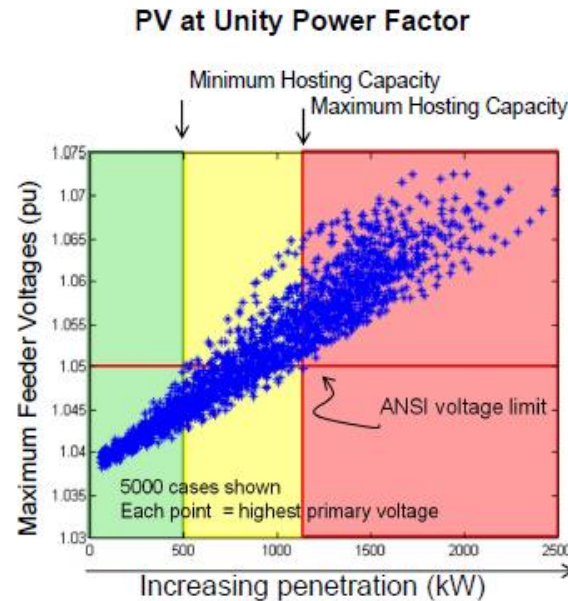
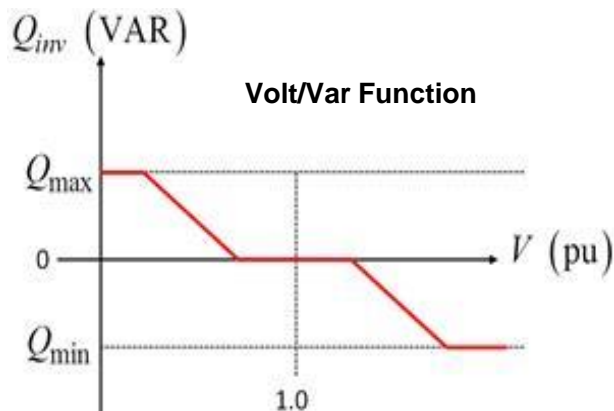
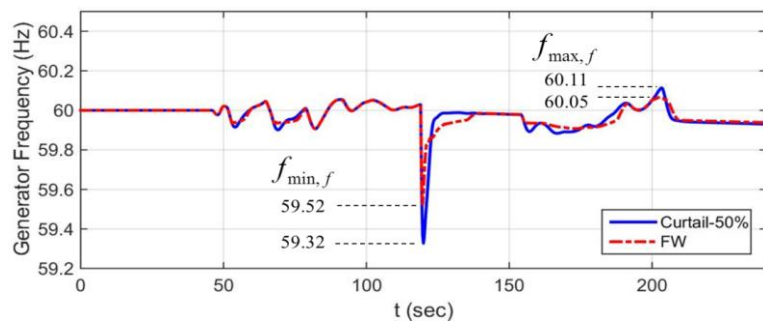

Illustration courtesy of B. Seal, EPRI

Frequency support with PV Inverters

- Frequency-watt functions reduce the depth of nadir.



- Frequency-watt can provide frequency regulation.

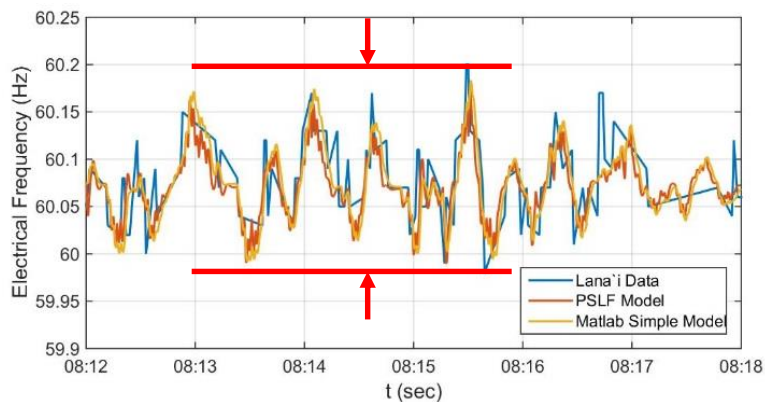

This article has been accepted for inclusion in a future issue of this journal. Content is final as presented, with the exception of pagination.

IEEE JOURNAL OF PHOTOVOLTAICS

Photovoltaic Frequency–Watt Curve Design for Frequency Regulation and Fast Contingency Reserves

Jay Johnson, Member, IEEE, Jason C. Neely, Senior Member, IEEE, Jarod J. Delhotal, Member, IEEE, and Matthew Lave, Member, IEEE

Abstract—When renewable energy resources are installed in electricity grids, they typically increase generation variability and displace thermal generator control action and inertia. Grid operators combat these emerging challenges with advanced distributed energy resource (DER) functions to support frequency and provide voltage regulation and protection mechanisms. This paper focuses on providing frequency reserves using autonomous IEC TR 61850-90-7 pointwise frequency-watt (FW) functions that adjust DER active power as a function of measured grid frequency. The importance of incorporating FW functions into a fleet of photovoltaic (PV) systems is demonstrated in simulation. Effects of FW curve design, including curtailment, deadband, and droop, were analyzed against performance metrics using Latin hypercube sampling for 20%, 70%, and 120% PV penetration scenarios on the Hawaiian island of Lanai. Finally, to understand the financial implications of FW functions to utilities, a performance function was defined based on monetary costs attributable to curtailed PV production, load shedding, and generator wear. An optimization wrapper was then created to find the best FW function curves for each penetration level. It was found that in all cases, the utility would save money by implementing appropriate FW functions.

Index Terms—Advanced inverter functions, advanced inverters, frequency regulation, grid-support functions, smart distributed energy resource (DER).

I. INTRODUCTION

IN JUNE 2015, the state of Hawaii, USA, passed a renewable portfolio standard bill that required Hawaiian utilities to generate 100% of their energy from renewable sources by 2045 [1]. In order for the Hawaiian Electric Industries to meet this requirement, an assortment of energy technologies must be implemented, including installation of energy storage systems (ESS) and activation of advanced grid-support functions in PV and other distributed energy resource (DER) inverters.

Advanced DER functions have been gaining acceptance in Europe and the United States as a cost-effective tool for improving grid stability. Grid codes around the world have been adding

grid-support requirements for photovoltaic (PV) and ESSs [2]–[6], major activities are creating interoperability standards to communicate with the devices [7]–[9], and international research teams are creating advanced DER testing protocols [10]–[13].

Frequency-watt (FW) implementation is required in DER in many European and California active power control and protection literature [14]–[16]. Grid codes are derived from the nameplate active for the curtailment and response time were found to be increasing power seconds when

This paper on multiple pe for the small at current and large number plug-in (LIS) [7] using General software and day (sunrise) to simulate in the latter power solar cycle. Fin of FW part loss due to cur

Lanai is a 14-residents as a 1 power system generators, the La Ola PV p is approximately does not en

Manuscript received April 25, 2016; revised June 30, 2016; accepted July 19, 2016. This work was supported by the U.S. Department of Energy SunShot program under Award 20092. Sandia National Laboratories is a multi-program laboratory managed and operated by Sandia Corporation, a wholly owned subsidiary of Lockheed Martin Corporation, for the U.S. Department of Energy's National Nuclear Security Administration under Contract DE-AC04-04AL15000. The authors are with the Sandia National Laboratories, Albuquerque, NM 87185 USA (e-mail: johnso2@sandia.gov; jneely@sandia.gov; jarod@ sandia.gov; mlave@sandia.gov).

Color versions of one or more of the figures in this paper are available online at <http://ieeexplore.ieee.org>.

Digital Object Identifier 10.1109/JPHOTOV.2016.2598725

2156-3381 © 2016 IEEE. Personal use is permitted, but republication/redistribution requires IEEE permission. See http://www.ieee.org/publications_standards/publications/rights/index.html for more information.

J. Johnson, J. Neely, J. Delhotal, M. Lave, Photovoltaic Frequency-Watt Curve Design for Frequency Regulation and Fast Contingency Reserves, IEEE Journal of Photovoltaics, 2016.

Evaluation of PV Frequency-Watt Function for Fast Frequency Reserves

J. Neely, Member, IEEE, J. Johnson, Member, IEEE, J. Delhotal, S. Gonzalez, M. Lave, Member, IEEE, Sandia National Laboratories, Albuquerque, NM, USA, jneely@sandia.gov

Abstract—Increasing the penetration of distributed renewable sources, including photovoltaic (PV) sources, poses technical challenges for grid management. The grid has been optimized over decades to rely upon large centralized power plants with well-established feedback controls, but some non-dispatchable, renewable sources are displacing these controllable generators. By programming autonomous functionality into distributed energy resources—in particular, PV inverters—the aggregated PV resources can act collectively to mitigate grid disturbances. This paper focuses on the problem of frequency regulation. Specifically, the use of existing IEC 61850-90-7 grid support functions to improve grid frequency response using a frequency-watt function was investigated. The proposed approach dampens frequency disturbances associated with variable irradiance conditions as well as contingency events without incorporating expensive energy storage systems or supplemental generation, but it does require some curtailment of power to enable headroom for control action. Thus, this study includes a determination of the trade-offs between reduced energy delivery and dynamic performance. This paper includes simulation results for an island grid and hardware results for a testbed that include a load, a 22 kVA diesel generator, and a 24 kW inverter.

Keywords—photovoltaics, IEC advanced functions, advanced inverters, frequency regulation, frequency-watt, PV curtailment.

I. INTRODUCTION

With plans to replace conventional power generation with renewable power, utilities fear large frequency and voltage excursions resulting from variability of renewable power generation, reduced mechanical inertia (for power electronic-coupled systems), and reduced grid support, i.e. voltage and frequency regulation. Some island power systems have realized high renewable penetration in a short time frame, and technical issues encountered therein are regarded by many as predictive for larger power systems in the U.S. In these island grids, PV systems are often required to also install expensive smoothing batteries [1] to mitigate the effect of PV fluctuations on the grid. The requirements are driven by concerns that the variability of renewable generators will overpower frequency regulating reserves provided by traditional generators, resulting in large frequency swings. These strict, expensive requirements could be lightened if the entire system were stabilized (rather than smoothing each plant individually). One method involves the implementation of grid support functions in grid-connected

This work was supported by the U.S. Department of Energy SunShot program under Award Number 20092. Sandia National Laboratories is a multi-program laboratory managed and operated by Sandia Corporation, a wholly owned subsidiary of Lockheed Martin Corporation, for the U.S. Department of Energy's National Nuclear Security Administration under contract DE-AC04-04AL15000.

Fig. 1. Overview of the Lanai power system, reproduced from [1]

A previous study of the 1.2 MW PV plant in Lanai, HI demonstrated that real power curtailment alone was an effective tool to reduce PV ramp rates and assist with frequency stability [3]. Unfortunately, when performing this control strategy, much of the DC power is left on the array. In this work, the Lanai power system is modeled and simulated assuming PV resources are configured to implement frequency-watt control. Evaluations of techno-economic performance are determined over a full day using a simplified model implemented in MATLAB [4], and final performance is evaluated over short time frames using a high-fidelity model developed in General Electric's Positive Sequence Load Flow (GE[®] PSLF). Several scenarios are considered with different PV penetration and grid-support function settings. In addition, a testbed was assembled using select hardware at the Distributed Energy Technology Laboratory (DETL), including a diesel generator and a PV inverter with frequency-watt capability. This testbed was used to evaluate the frequency-watt function's ability to mitigate frequency deviations on a small power system with large steps in load.

J. Neely, J. Johnson, J. Delhotal, S. Gonzalez, M. Lave, Evaluation of PV Frequency-Watt Function for Fast Frequency Reserves, IEEE Applied Power Electronics Conference (APEC), Long Beach, CA, March 20-24, 2016.

Peak Shaving (Reducing the Max Load)

- Reminder: generation = load.
- At peak load times, the price of electricity is high because grid operators are using older, less efficient power plants.
 - Utilities are also charged based on peak load for transmission upgrades.
- Energy storage (e.g., batteries) can reduce the net peak load.
 - Often batteries are charged by solar generation.

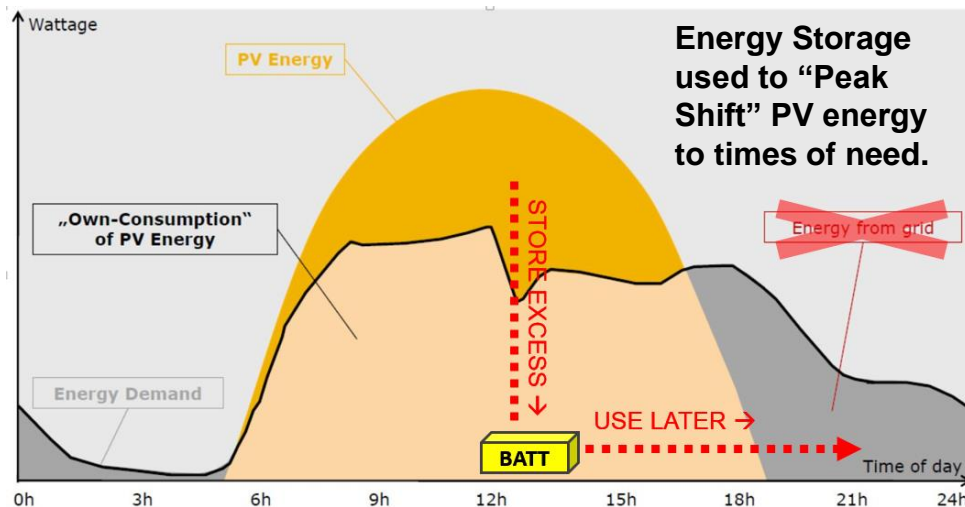
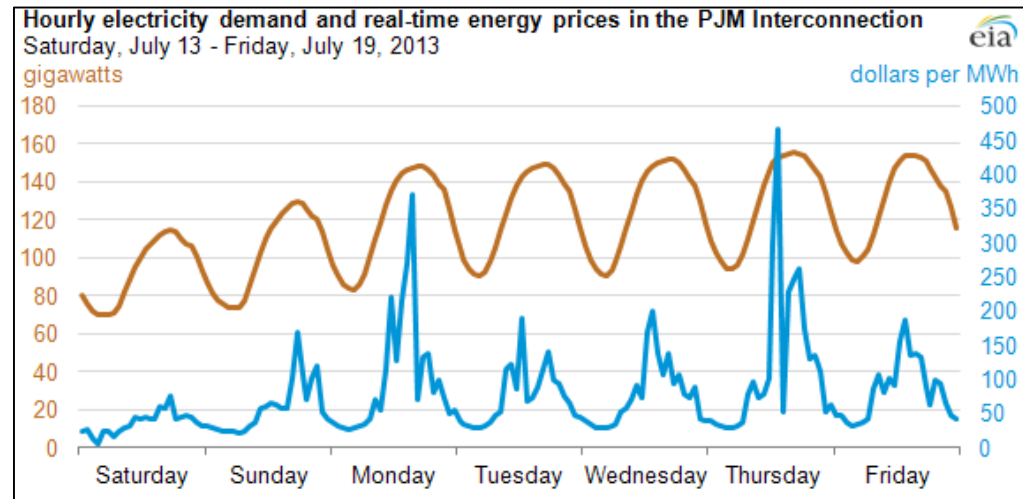

Notes: 1) Depending on size /type of system; Min. to max. tariff in 2013 of new EEG 2012 2) Depending on electricity retail price of respective utility company.

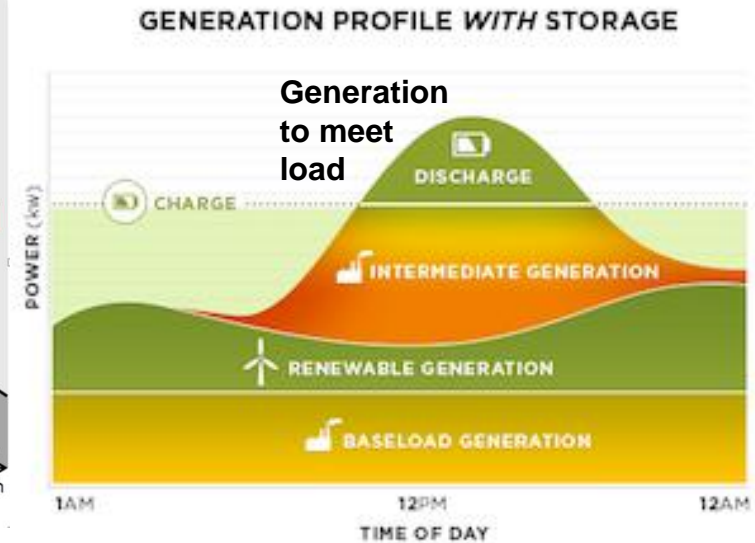

Peak Shifting at Stafford Hill, VT

- Sandia is collaborating with Green Mountain Power (Vermont utility) to provide peak shaving based on ISO NE load forecast.
- 2 MW of PV stored in 4 MW of battery storage and discharged at peak load.
- This is flattening the duck by increasing the solar dip and decreasing the peak load.
 - This also helps reduce the load ramp rate.

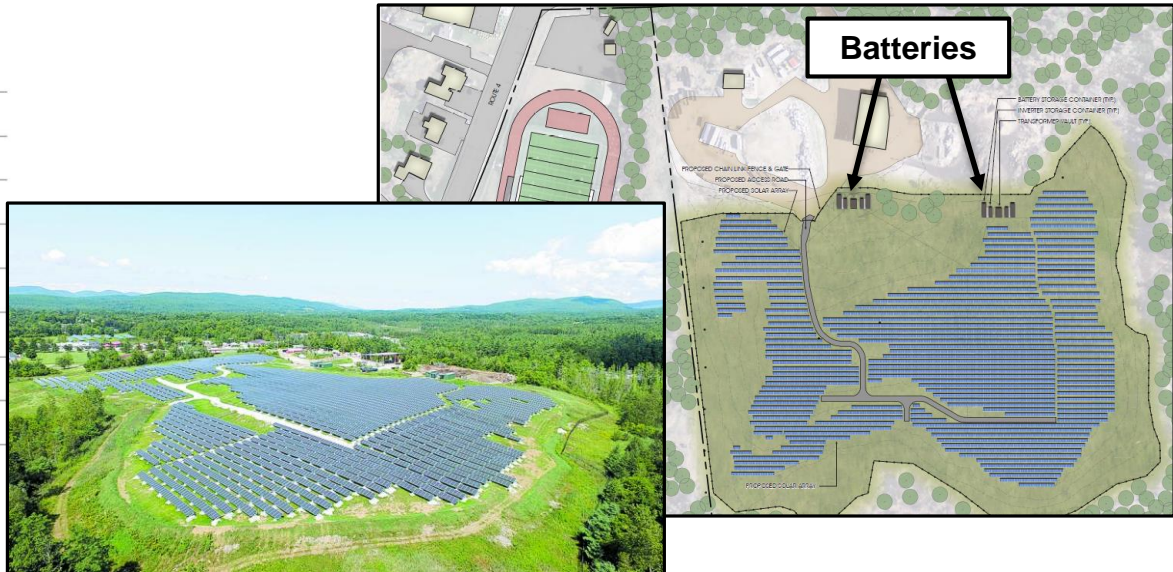
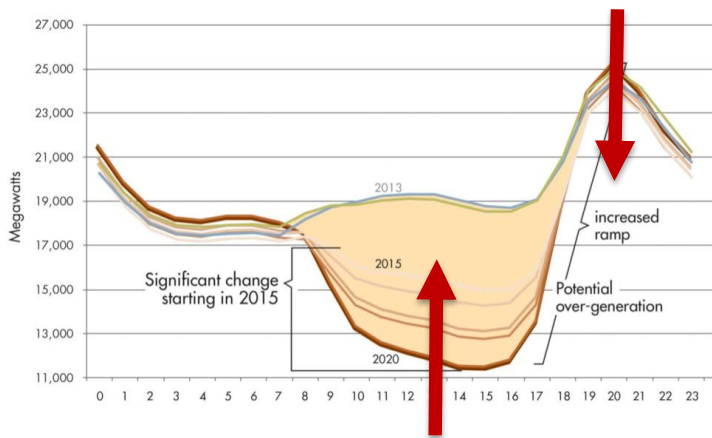

PV Smoothing with Battery and Diesel Genset



Goal: Locally assist grid operators with rapid voltage and power changes

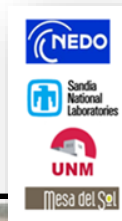
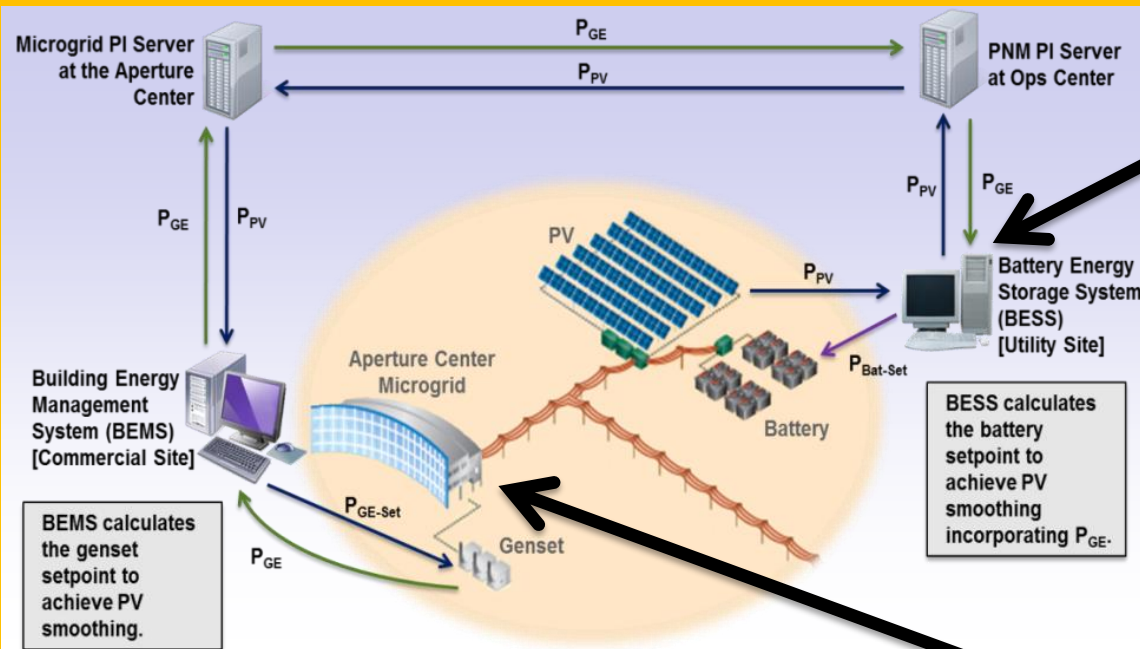

BEMS



Plant yard



PV panel



Distribution board

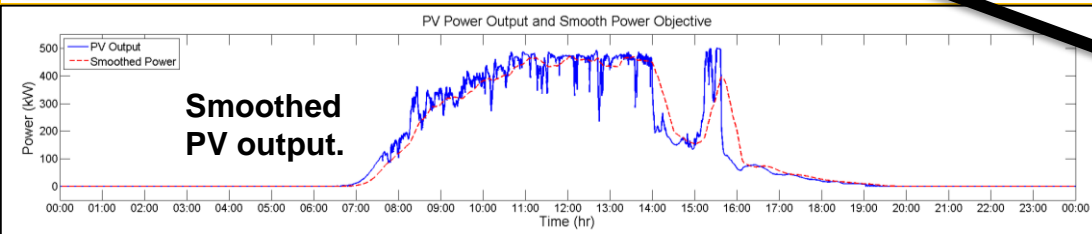

Smart Electricity Grid

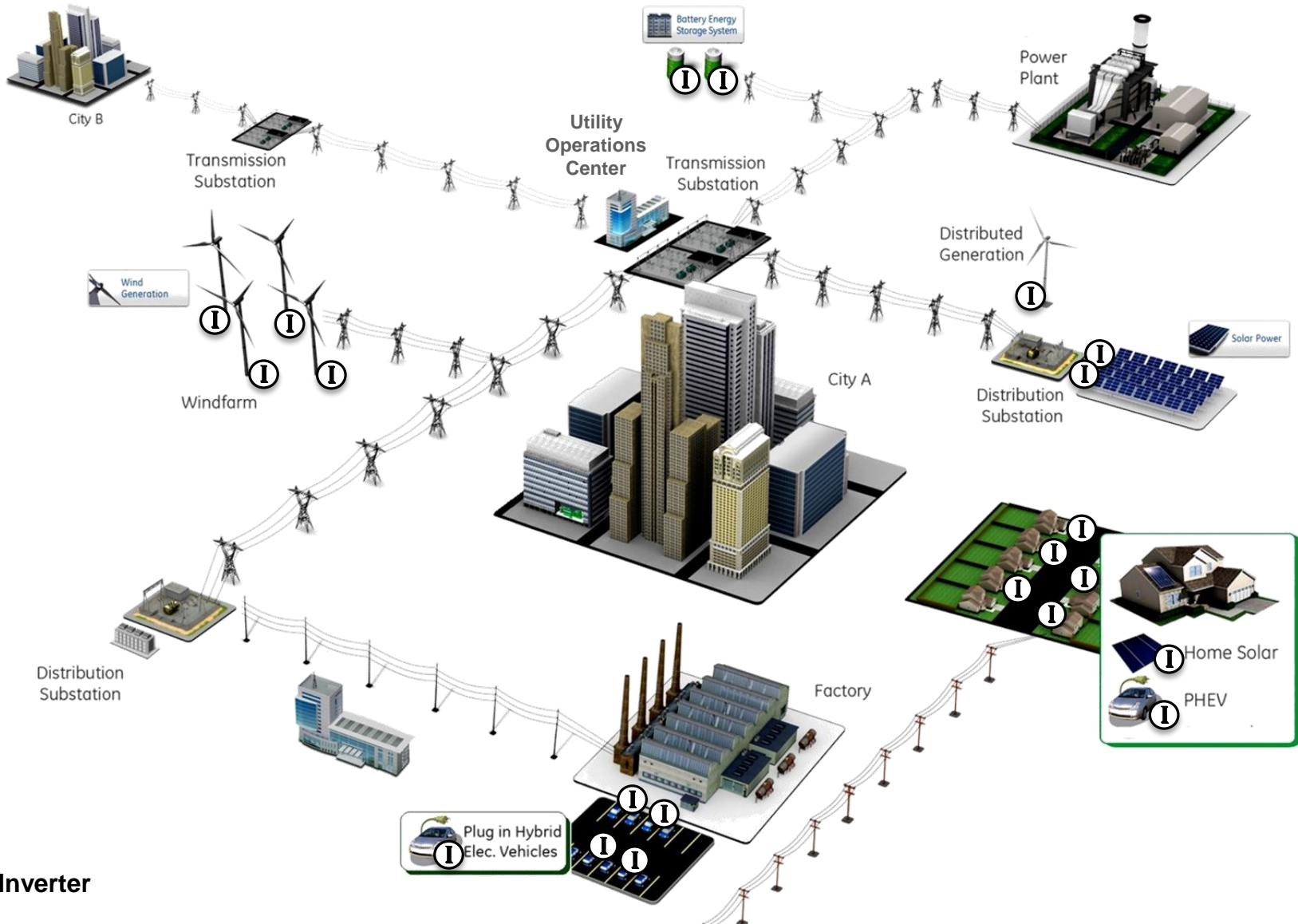

Smart Electricity Grid Communications

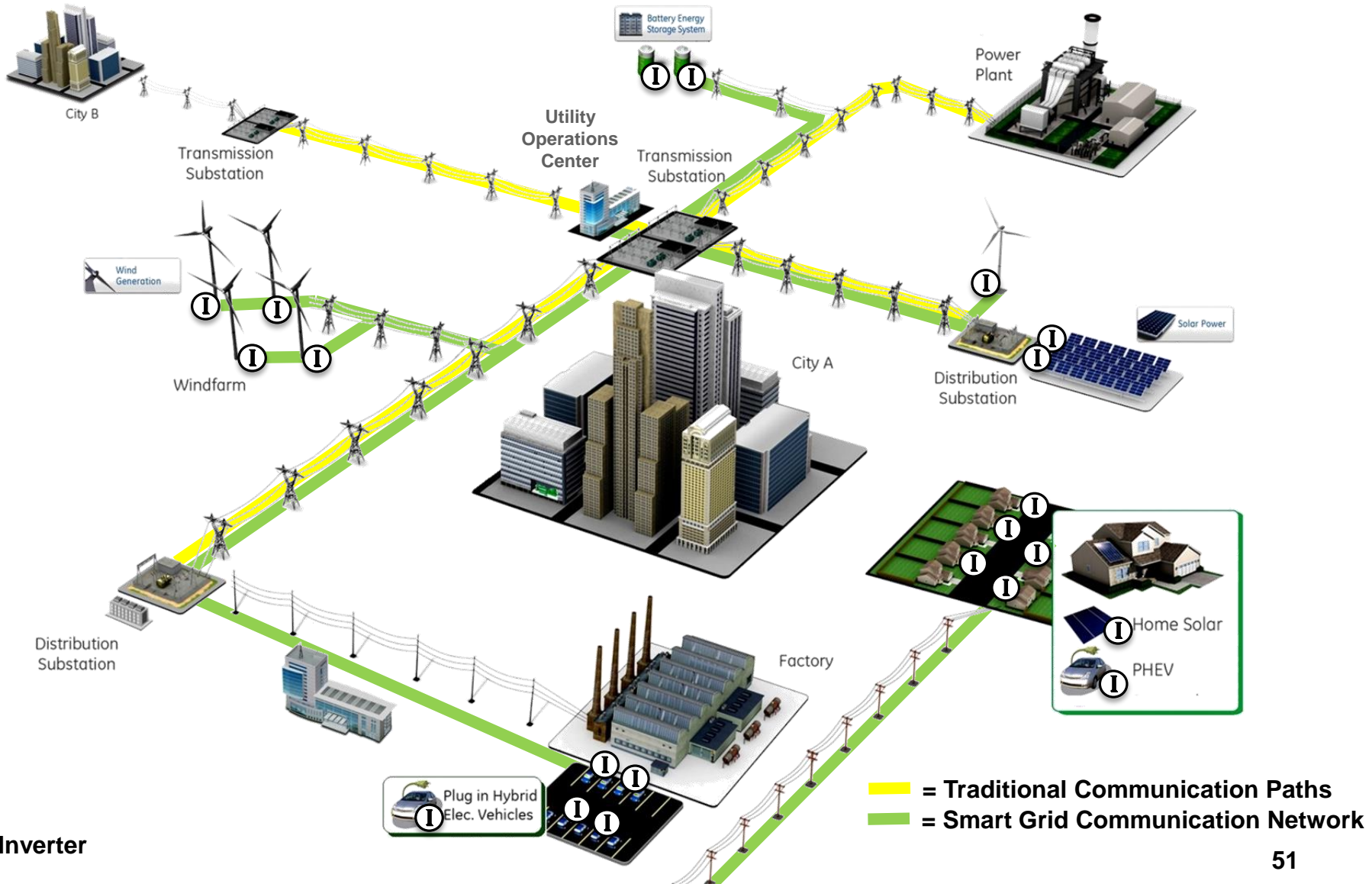

Smart Electricity Grid Communications

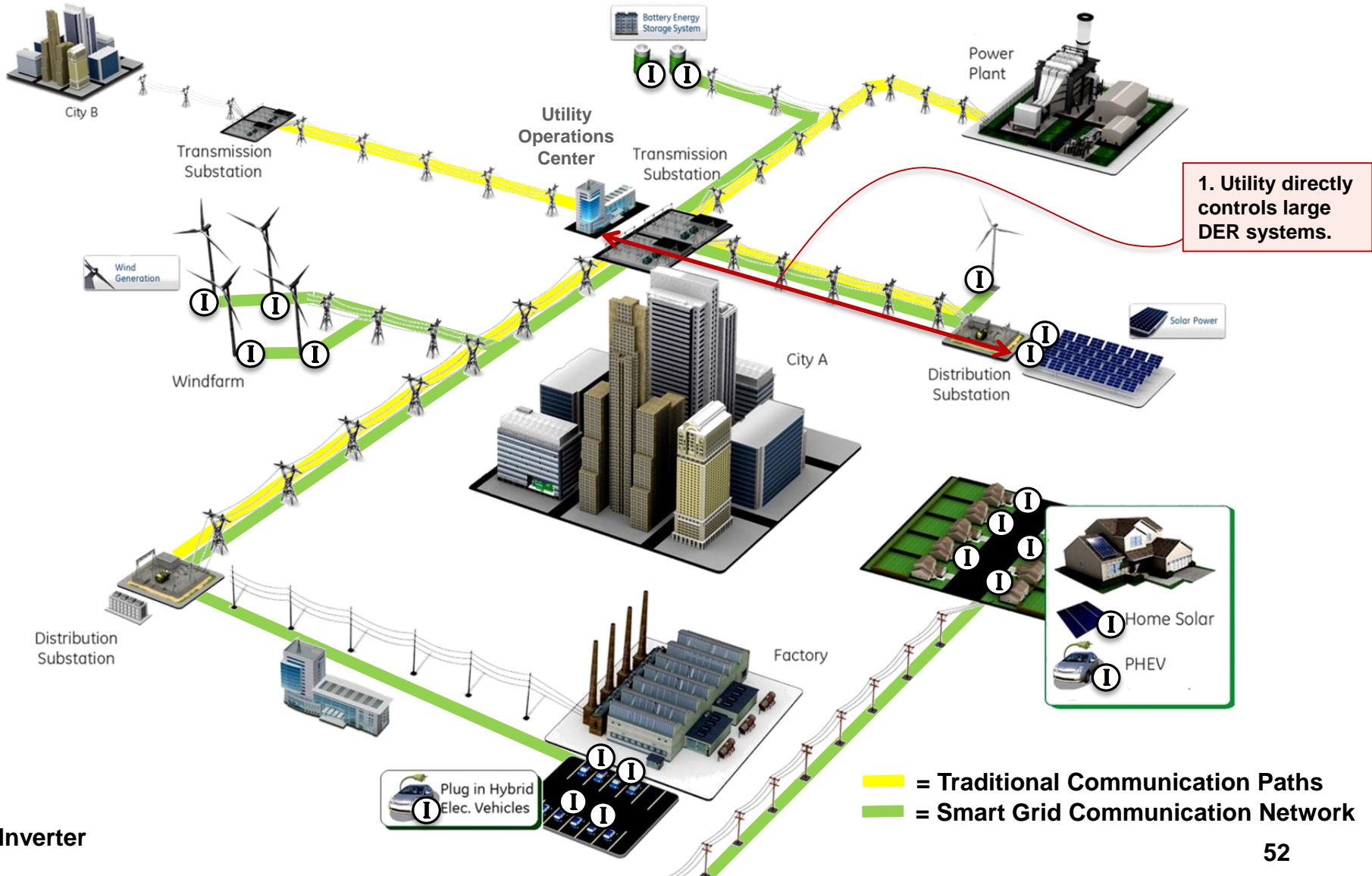

Smart Electricity Grid Communications

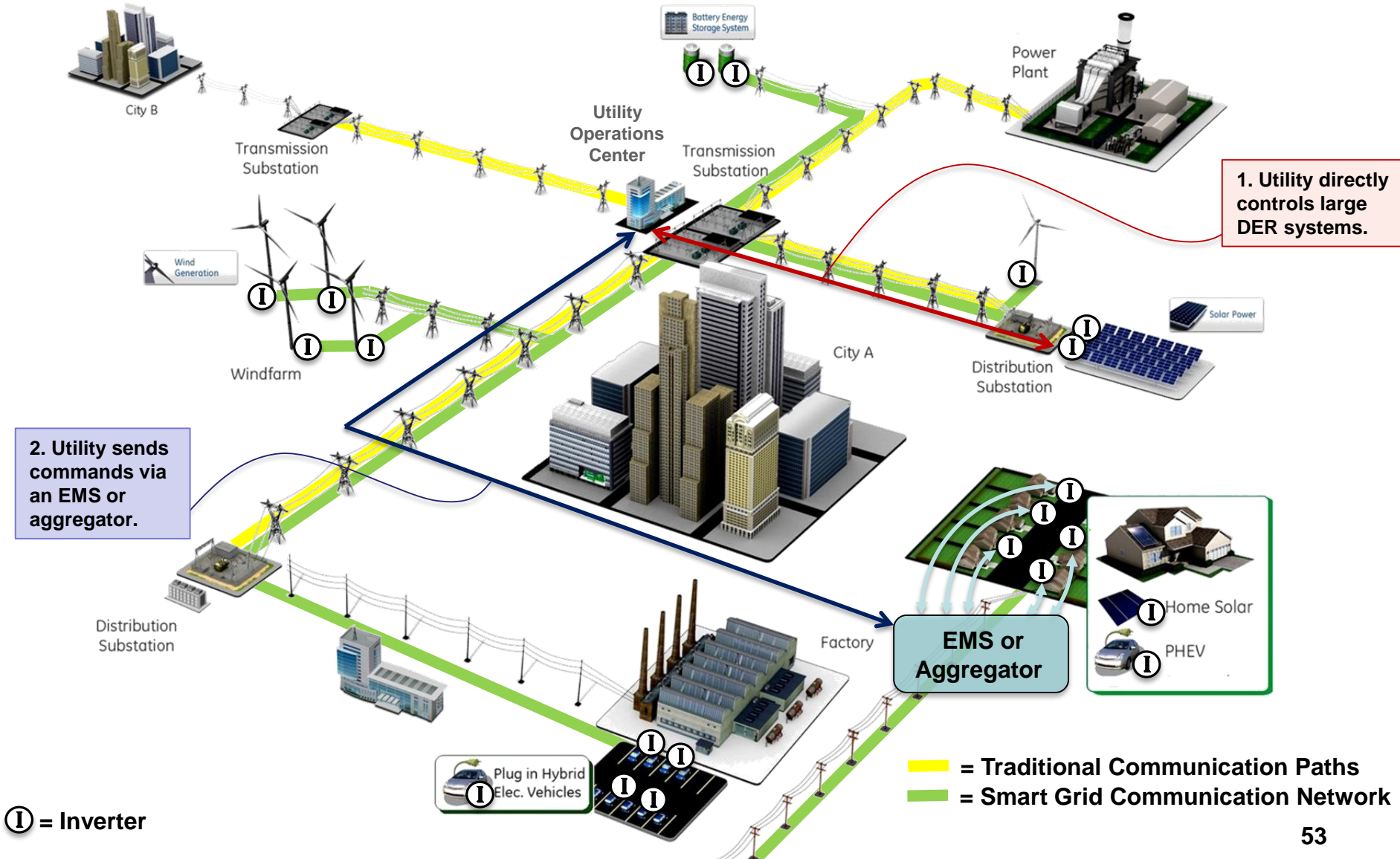

Smart Electricity Grid Communications

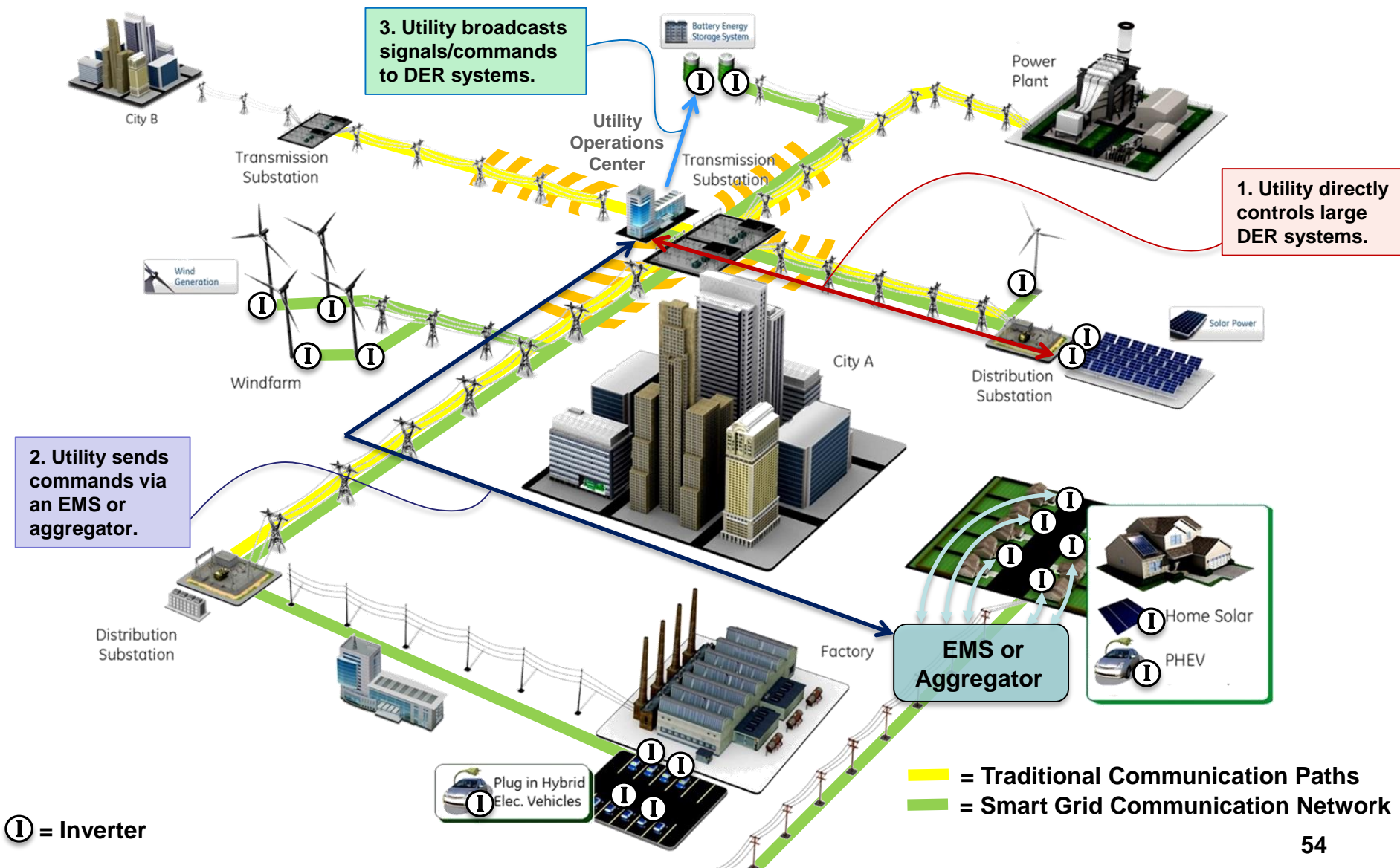

Communications/control architecture

- How will utility, aggregators, and smart inverters interact?
- Competing communications solutions
 - Protocols: DNP3, SEP 2.0, IEC 61850, Modbus, OpenADR, SunSpec
 - Medium: Wi-Fi, CAT6, PLC
 - Method: direct, broadcast
- Open challenges
 - Interoperability
 - Cybersecurity
 - Optimization
 - Utility Integration

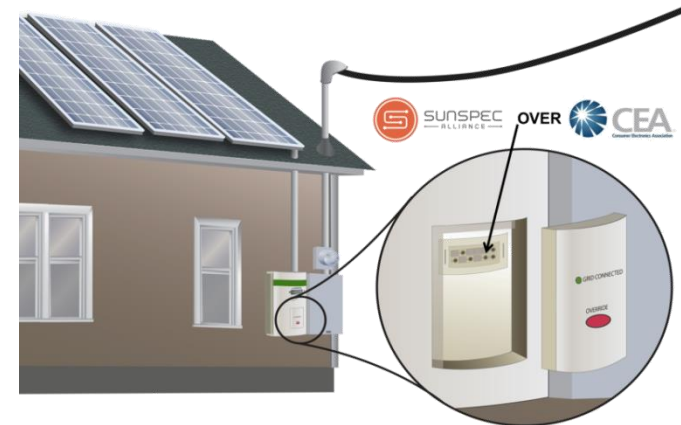

Possible Translation Idea: SEP 2.0 to Modbus

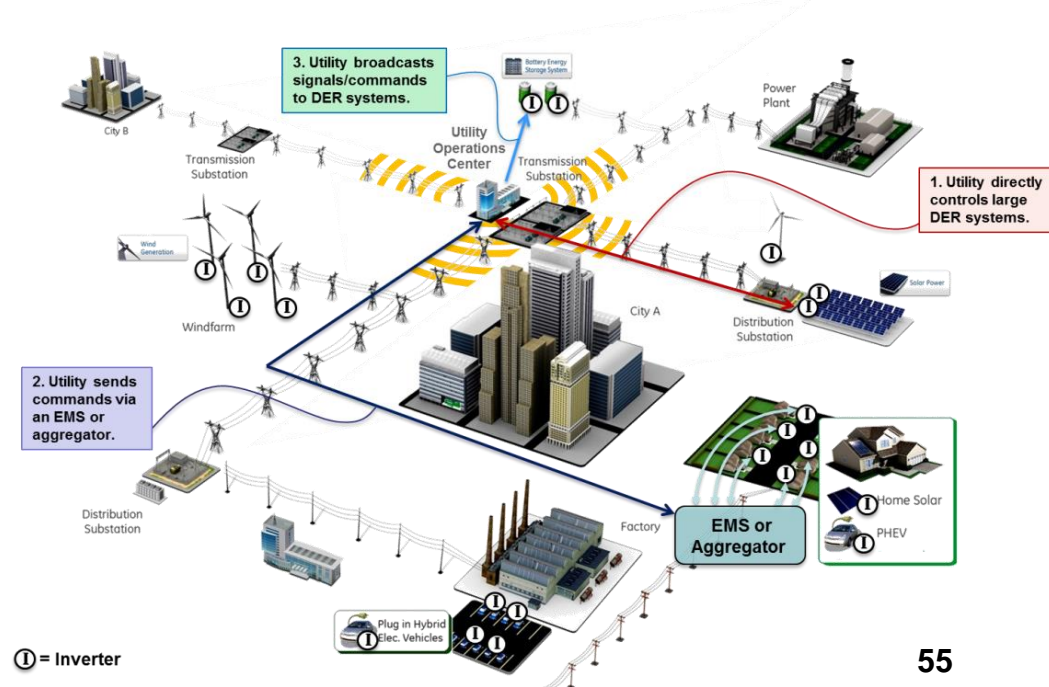

New Communications = Cybersecurity Issues!

DHS's Industrial Control Systems Cyber Emergency Response Team (ICS-CERT) coordinates control systems-related security incidents and information sharing with federal agencies; state, local, tribal, and territorial governments; and control systems owners, operators, and vendors to reduce the risk of cyber attack against the Nation's critical infrastructure.

There were 245 incidents reported to ICS-CERT in 2014. There were 295 in 2015.

FY 2015 Incidents by Sector (295 total)

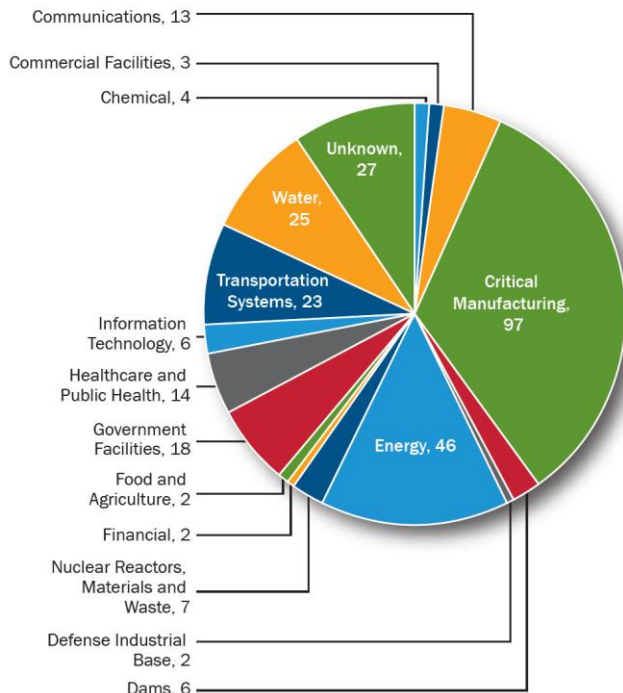

FY 2015 Observed Depth of Intrusion

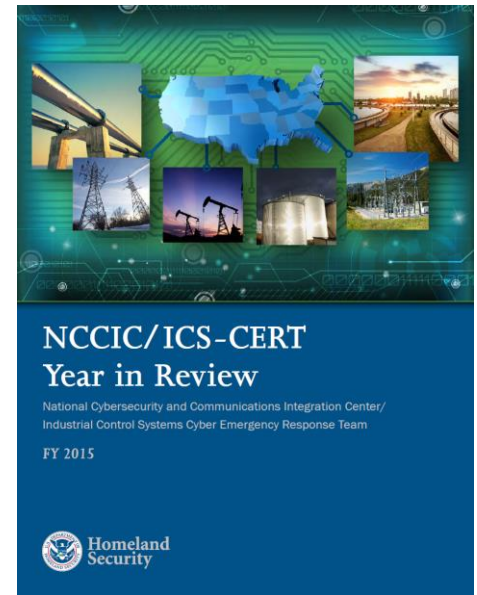
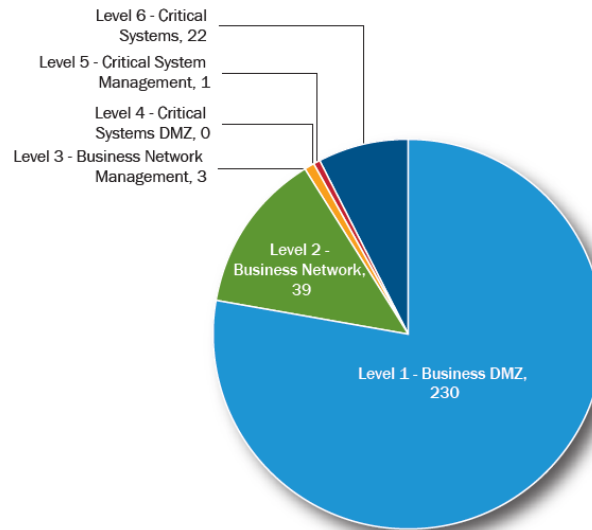

Latest published vulnerabilities

- ICSA-16-264-01 : Moxa Active OPC Server Unquoted Service Path Escalation Vulnerability 09/20/2016
- ICS-ALERT-16-263-01 : BINOM3 Electric Power Quality Meter Vulnerabilities 09/19/2016
- ICSA-16-259-01 : Yokogawa STARDOM Authentication Bypass Vulnerability 09/15/2016
- ICSA-16-259-02 : ABB DataManagerPro Credential Management Vulnerability 09/15/2016
- ICSA-16-224-02 : Rockwell Automation RSLogix 500 AND RSLogix Micro File Parser Buffer Overflow Vulnerability 09/15/2016
- ICS-ALERT-16-256-01 : FENIKS PRO Elnet Energy Meter Vulnerabilities 09/12/2016
- ICS-ALERT-16-256-02 : Schneider Electric ION Power Meter CSRF Vulnerability 09/12/2016

Cyber Security Attacks on Energy Systems

Ukrainian Blackout, December 23, 2015

- Coordinated cyber attacks three oblenergos (distribution companies), resulting in power outages affecting approximately 225,000 customers for 3 hours.
 - Seven 110 kV and 23 35 kV substations were disconnected
- Planned for months before the blackout using BlackEnergy 3 and KillDisk (malware installed through spear phishing)
 - Keystroke loggers stole credentials
 - VPNs used to enter ICS network
 - Master boot records erased
- Russian security services blamed for attack.
- Would be worse in US, because we don't have manual backup functionality for grid control systems.



<https://www.wired.com/2016/03/inside-cunning-unprecedented-hack-ukraines-power-grid/>

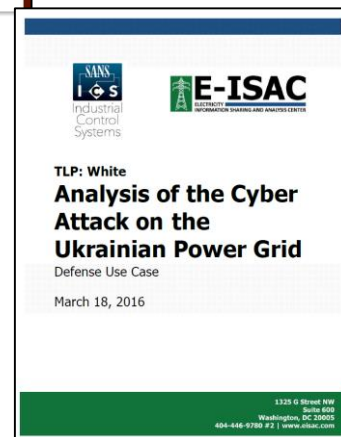

Analysis of the Cyber Attack on the Ukrainian Power Grid - NERC



Sandia's Integrated Cybersecurity Research

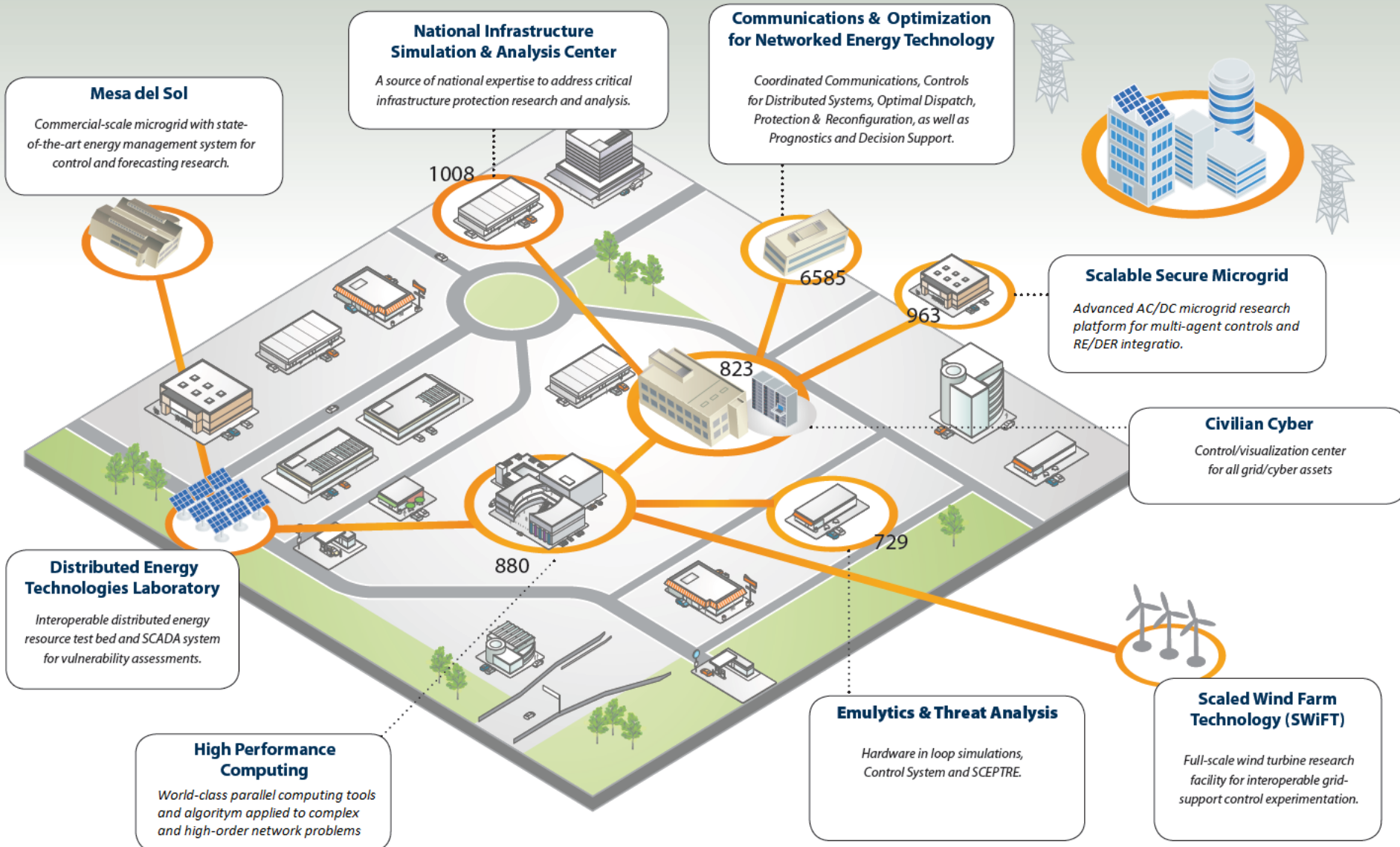

Cyber defense against DER data manipulation

- Scenario: modify inverter performance data to cause billing problems and adjust control set points to impact grid stability
- Analysis at Sandia combines SNL's cyber, power system, and critical infrastructure modeling and simulation capabilities

PV Panels & Microinverters

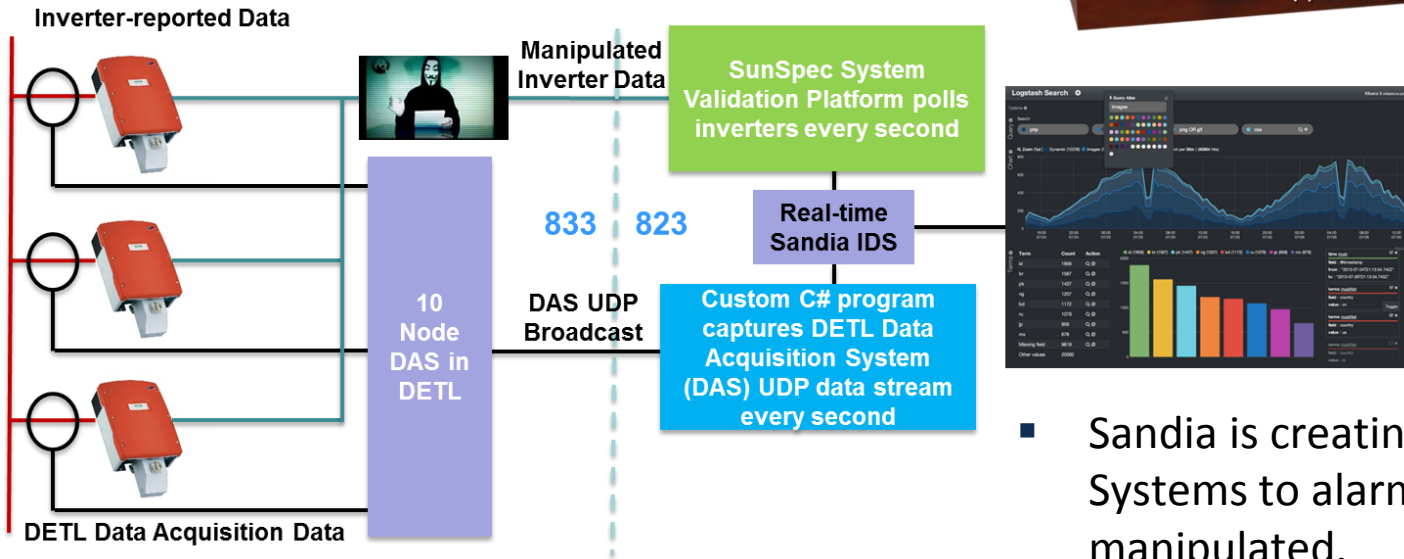
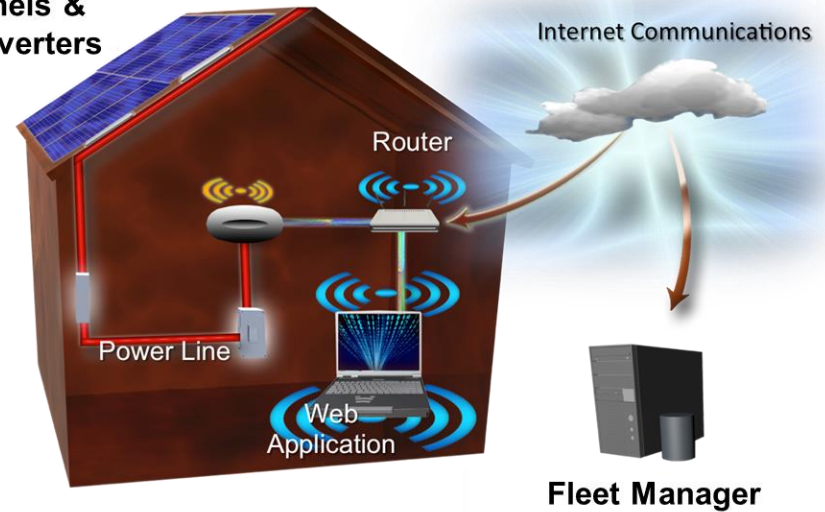

- Sandia is creating Intrusion Detection Systems to alarm when DER data is manipulated.

PV Codes and Standards Evolution is Now!

- Exciting times for the US as we create new *interconnection* and *interoperability* standards
 - (AKA I spend a lot of time on teleconference calls)
- **Interconnection Standards** specify the requirements and processes to physically **connect** devices to the grid without adversely impacting electric system components, reliability or stability.
 - Includes the advanced inverter grid-support functions
 - CA and HI have made changes to the rules for inverters.
 - The certification standard (UL 1741) published Sept 8, 2016!
 - National requirement (IEEE 1547) is being updated now
- **Interoperability Standards** specify the requirements & processes needed for devices to **communicate** and exchange information with other grid components and systems in a secure and effective manner.
 - Information models and communication requirements are being harmonized with the interconnection requirements: see IEC 61850, DNP3, SEP 2.0, SunSpec Modbus, etc.
- Currently participating in a codes and standards gap analysis with the Grid Modernization Laboratory Consortium

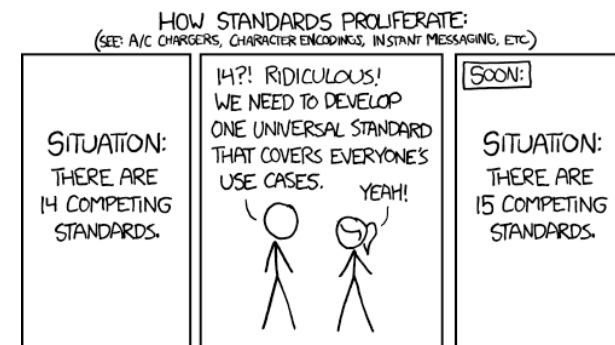
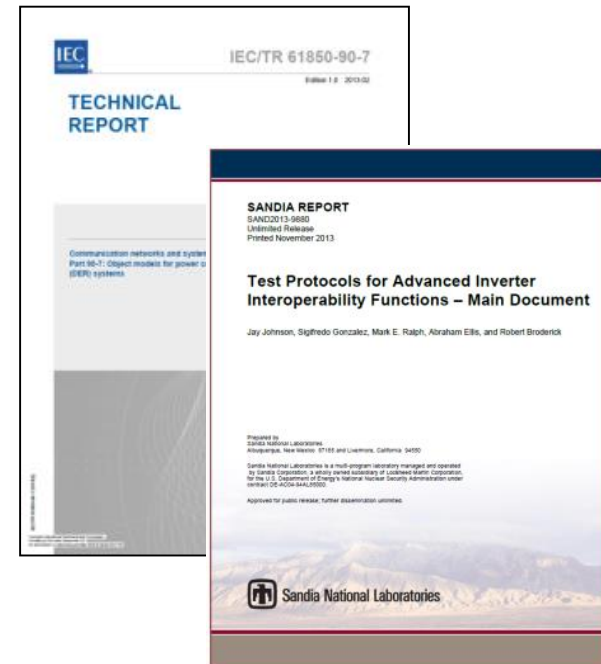

<https://xkcd.com/927/>

SIRFN Testing Laboratories are creating and executing ESS Certification Protocols



Team members at AIT Smart Electricity Systems and Technologies (SmartEST) PV Inverter Test Laboratory



Team Members at RSE Distributed Energy Resource (DER) Test Facility

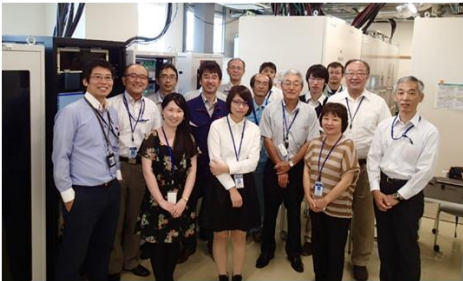

Team members at FREA Smart DER Research Facility



Team Members at Sandia's Distributed Energy Technologies Lab (DETL)

Protocols active power, reactive power, fixed power factor, volt-var, and frequency-watt.

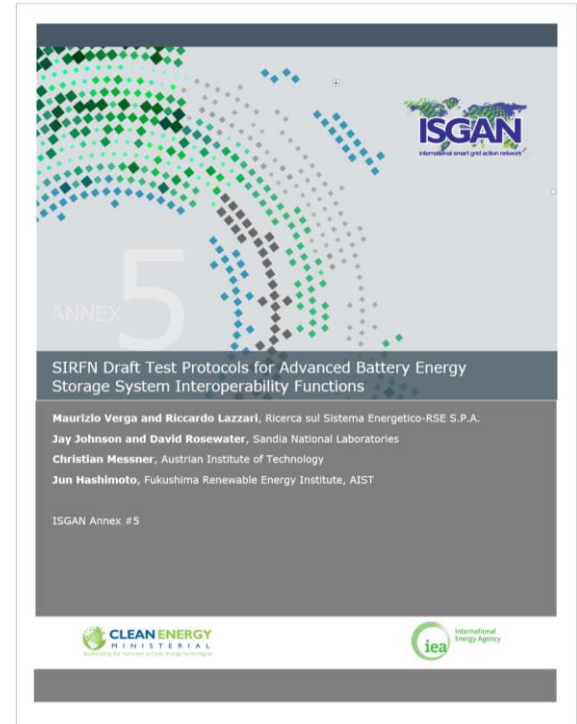

M. Verga, R. Lazzari, J. Johnson, D. Rosewater, C. Messner, J. Hashimoto, SIRFN Draft Test Protocols for Advanced Battery Energy Storage System Interoperability Functions, ISGAN Annex #5 Discussion Paper, 2016.

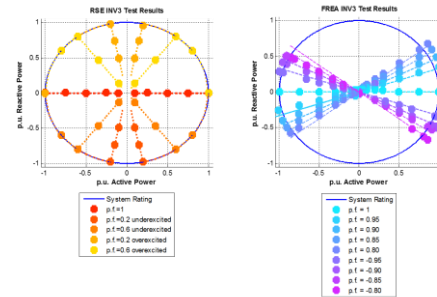
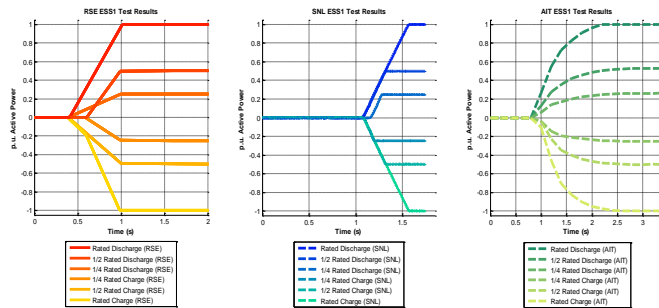

Sandia Impacts on Renewable and Distributed Systems Integration R&D

- Sandia has made major contributions to DER and RE grid integration over 35 years of work in this space
 - Advanced inverters, AI technologies, microgrid design, advanced UC/ED, ...
 - Analysis, mod/sim, development & validation, full-scale demonstrations
 - Partnerships: manufacturers, utilities, universities, standards organizations
- **Increasing focus on optimization, distributed controls, interoperability, cybersecurity**

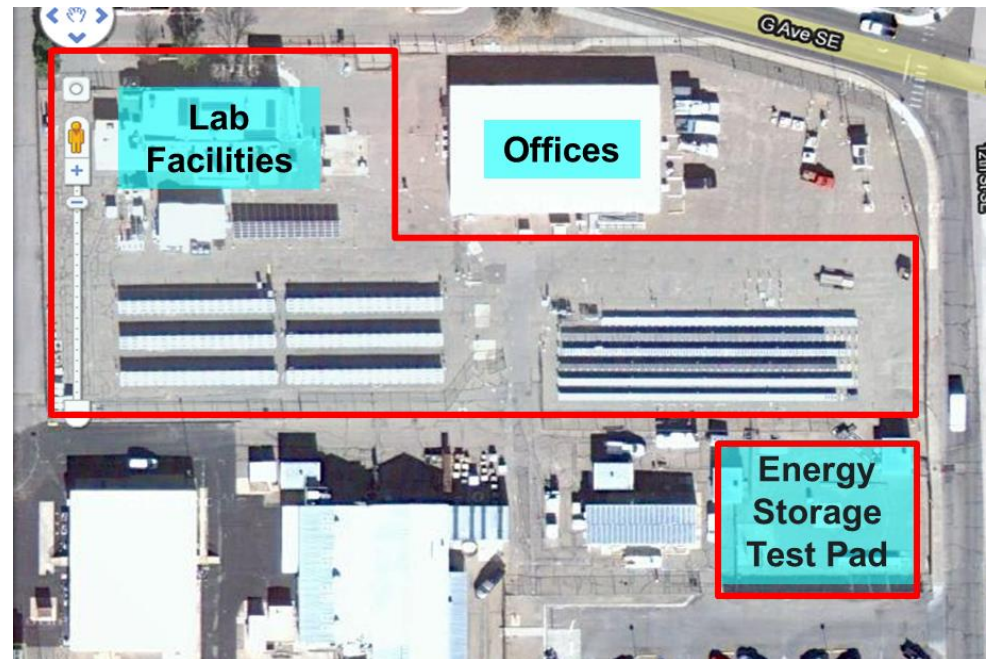

Distributed Energy Technologies Laboratory (DETL)

Virtual Power Plants

- VPPs are aggregations of DER assets controlled to provide identical (or superior) grid-support services compared to traditional generators.
 - Enables renewable energy, demand response, and energy storage to provide grid services
 - Improves grid reliability by providing additional operating reserves to utilities and ISO/RTOs
 - Removing renewable energy high-penetration barriers
- Goal: Develop a unified platform incorporating resource forecasting, standard communications, optimization, and control/dispatch to provide grid services with DERs.

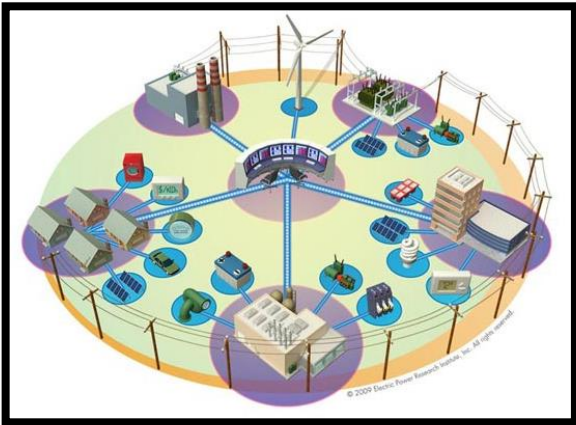

Virtual power plant with communication network (EPRI)

IV



Lake Side natural gas turbine power station in Vineyard, Utah. (Wikipedia Commons)

Sandia's Virtual Power Plant Research

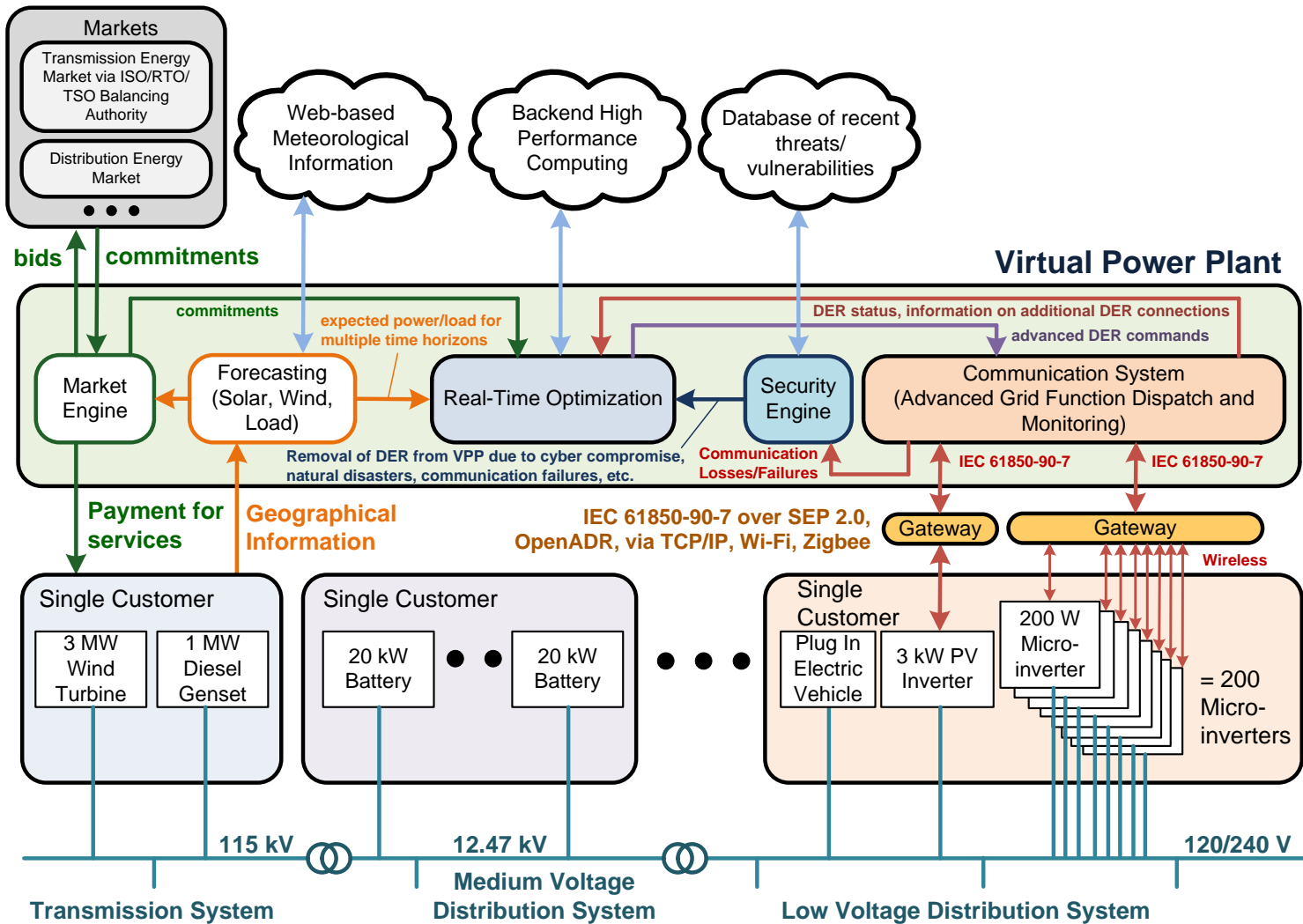

DETL generators will be used for the Virtual Power Plant demo in 2017

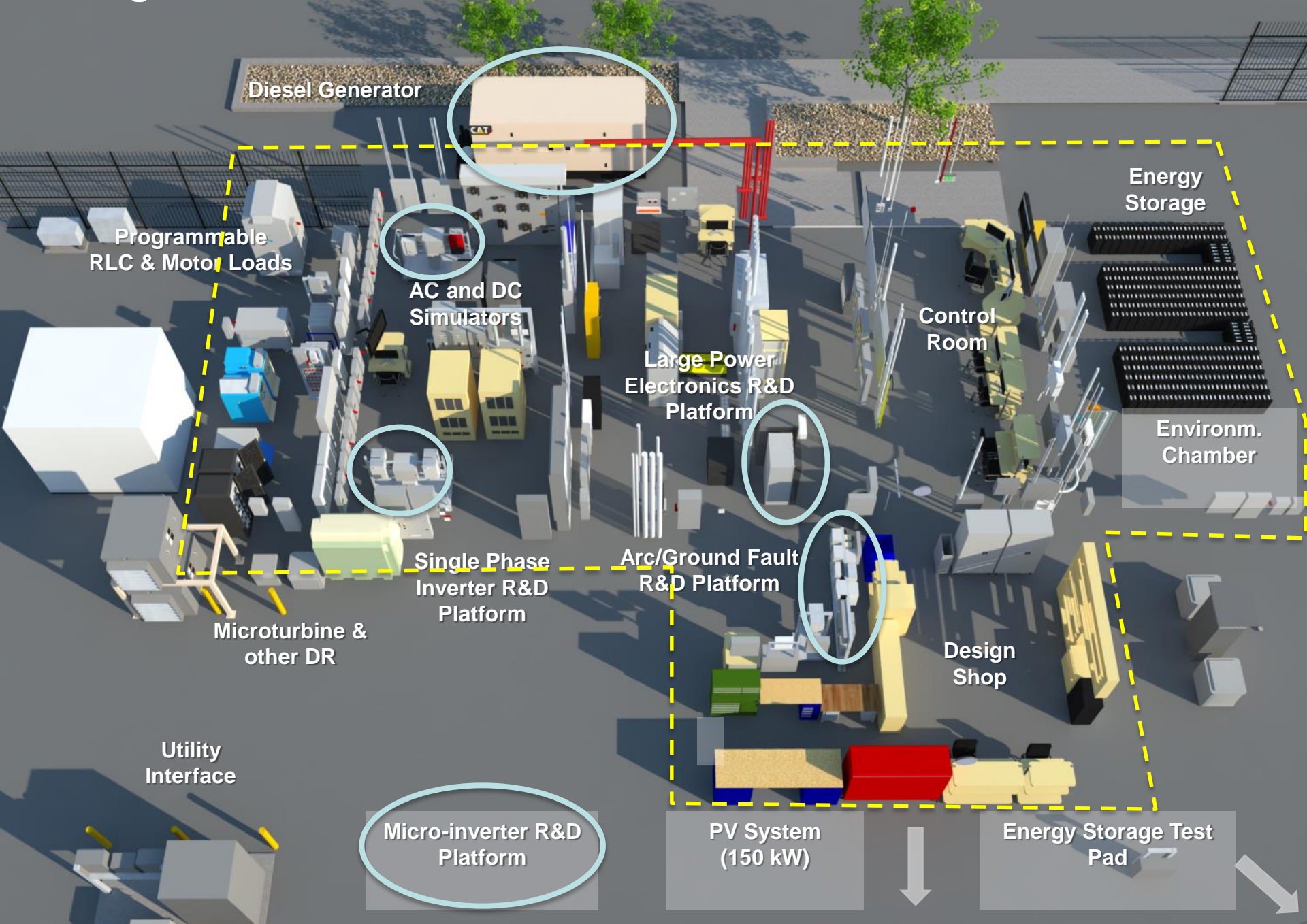

Conclusions

- Renewable energy offers clean, affordable power
- There are a number of challenges with grid-interconnected PV and other renewable energy systems
 - Bulk frequency issues
 - Voltage control issues
- Inverter are slowly being updated to include grid-support functionality
 - Codes and standards drive these changes, but take time
 - New interconnection and interoperability codes are evolving now
- Sandia is researching different ways to support grid operators with these new capabilities.
 - More results soon!

Questions?

Jay Johnson

Photovoltaic and Distributed Systems Integration

Sandia National Laboratories

P.O. Box 5800 MS1033

Albuquerque, NM 87185-1033

Phone: 505-284-9586

jjohns2@sandia.gov