

# THE WHOLE SYSTEM TRADES ANALYSIS TOOL FOR AUTONOMOUS GROUND SYSTEMS



Booz | Allen | Hamilton

Sandia National Laboratories

Michael R. DiNunzio

Stephen M. Henry  
Lucas A. Waddell

James Ealy  
Ryan Pykor  
Michael Zabat

Overall Classification of the brief is: **UNCLASSIFIED**

**DISTRIBUTION A. Approved for public  
release: distribution unlimited.**

GVSETS 2016  
August 4, 2016

# Squad Multipurpose Equipment Transport

The Squad Multi-purpose Equipment Transport (SMET) is an unmanned ground system (UGS), essentially a “robotic pack mule,” that is currently being developed for PEO Combat Support and Combat Service Support (CS&CSS) under PdM Appliqué and Large Unmanned Ground Systems (ALUGS).



## SMET High-level Program Goals

1. Reduce the load carried by dismounted soldiers
2. Sustain a squad for an extended time over a large range without the need for resupply from a parent unit



# SMET Design Challenges

The SMET needs to:

- carry a squad's cargo,
- generate power to recharge batteries,
- host modular mission payloads,
- silently maneuver with the soldier,
- keep up with the squad,
- operate autonomously or semi-autonomously,
- be transportable,
- be reliable,
- be rugged,
- be survivable,
- be upgradable,
- be cost effective, ...

The fields of robotics and autonomy are constantly evolving, meaning that there is an **extremely rich set of state-of-the-art and near-future technologies** that could be employed in an SMET configuration.

This presentation will introduce a **multi-objective trade space optimization** capability that provides quantitative, defensible insights into high-level **SMET design choices** regarding, for example:

1. Power plant (conventional vs. fuel cell vs. internal electric vs. hub motor vs. hybrid)
2. Running gear (wheels vs. tracks vs. mattracks)
3. Steering type (Ackerman vs. skid vs. pivot)
4. Autonomy levels (no autonomy, leader-follower, waypoint navigation, full autonomy)



# WSTAT Multi-objective Optimization

- The Whole System Trades Analysis Tool (WSTAT) is a joint Army/Sandia/BAH capability that allows exploration and evaluation of system configurations, keeping those that best balance competing design objectives

Powertrain



Chassis & Body

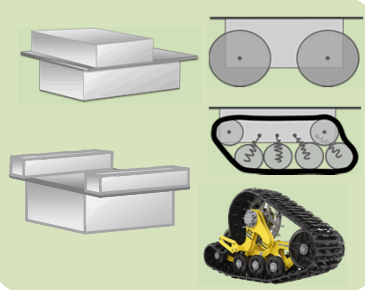

Comms & Control



Sensors



Collection of Available Technology Options

Technologies are selected to create a configuration

SMET Configurations

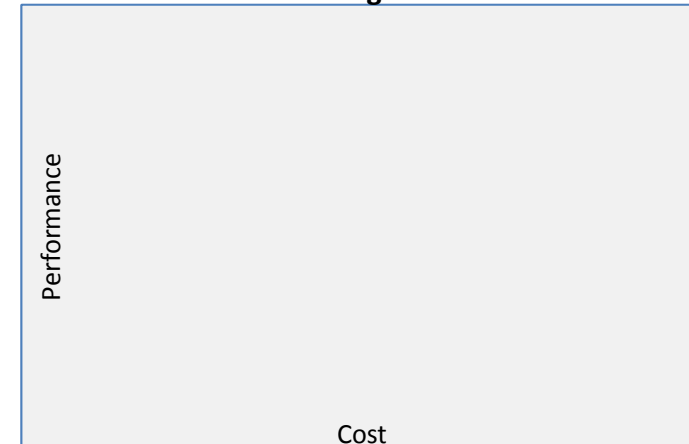

As the optimization runs, it finds better and better solutions



# WSTAT Study Legacy





# SMET WSTAT Pareto Optimality

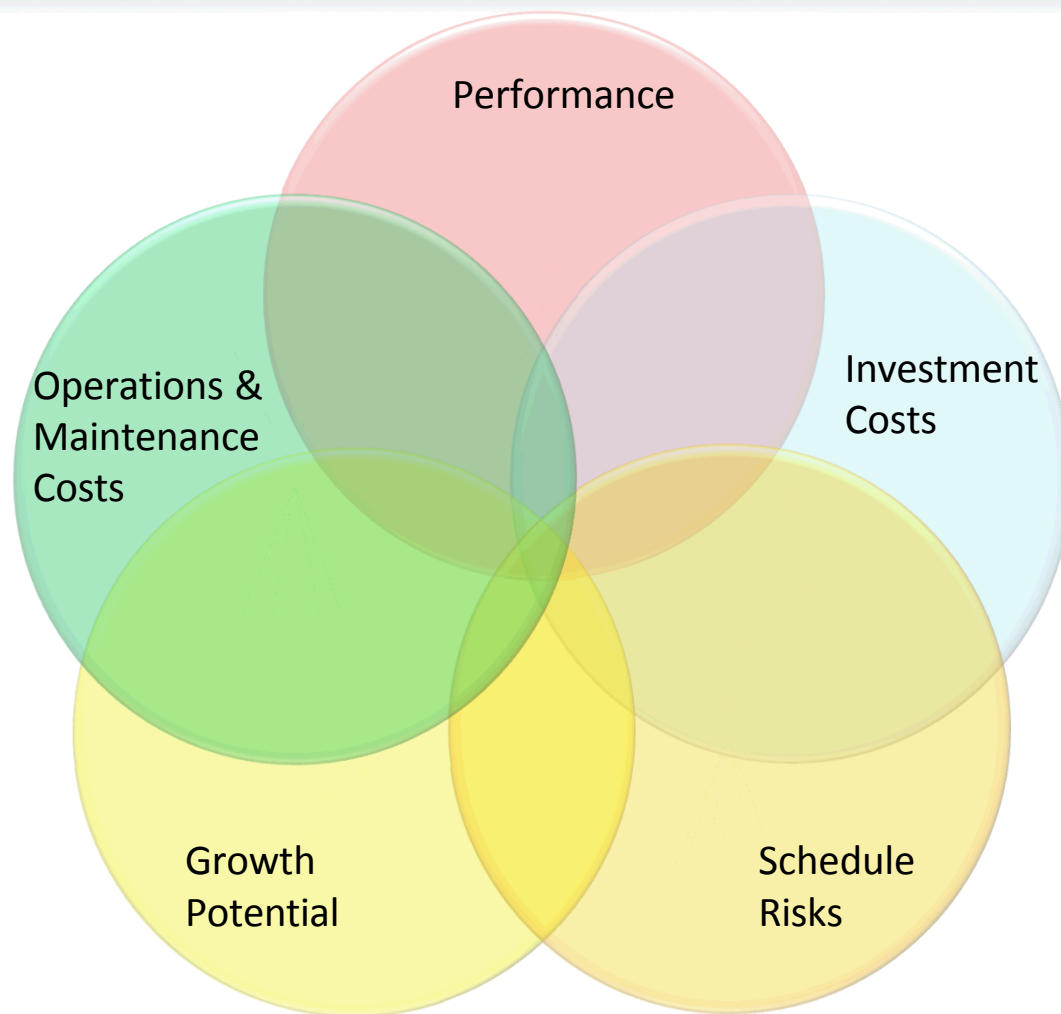

**SMET WSTAT Optimization Goal:** Find a spectrum of system designs that optimally balance the 5 dimensions of stakeholder value in various ways



# WSTAT Process

## Map Requirements to Functional Objectives

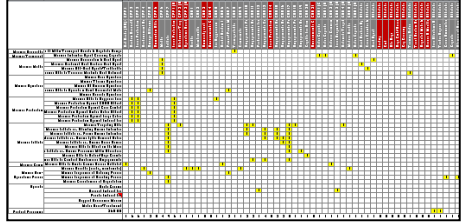

## Map Functional Objectives to Product Structure



## Define Metrics

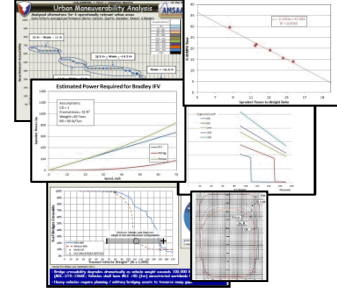

## Craft Value Functions

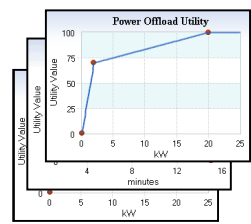

## Determine Priority Weightings

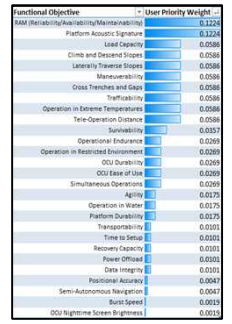

### Develop Functional Objectives

Safely and rapidly transport infantry to decisive locations and provide direct fire support

- Ex. Deployable
- Accommod. for Personnel & Equipment
- Mass Personnel & Equipment
- Asset Energy Allocation
- Protect Personnel and Equipment
- Acquire and Retain Enemy Targets
- Survivability & Security Exchange (Mission with Minimum Exposure to IFF)
- Synthesize & Integrate Information with Network Elements
- Enable Remote Operations

### Establish Product Structure

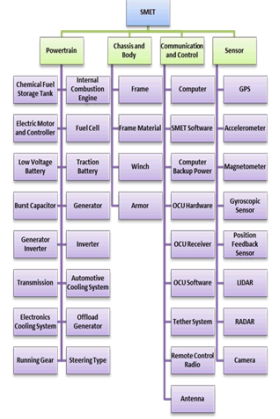

### Identify Technology Options



### Understand Needs/Requirements

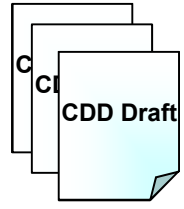

### Run Optimization and Generate Results

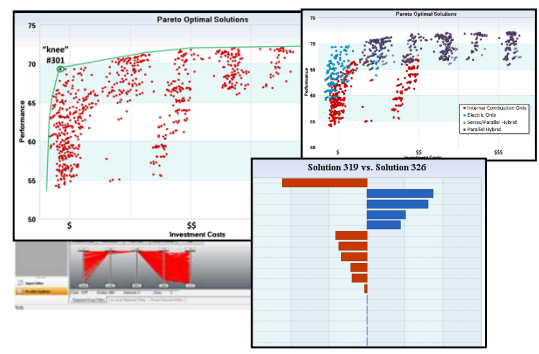



# SMET Functional Objective Hierarchy

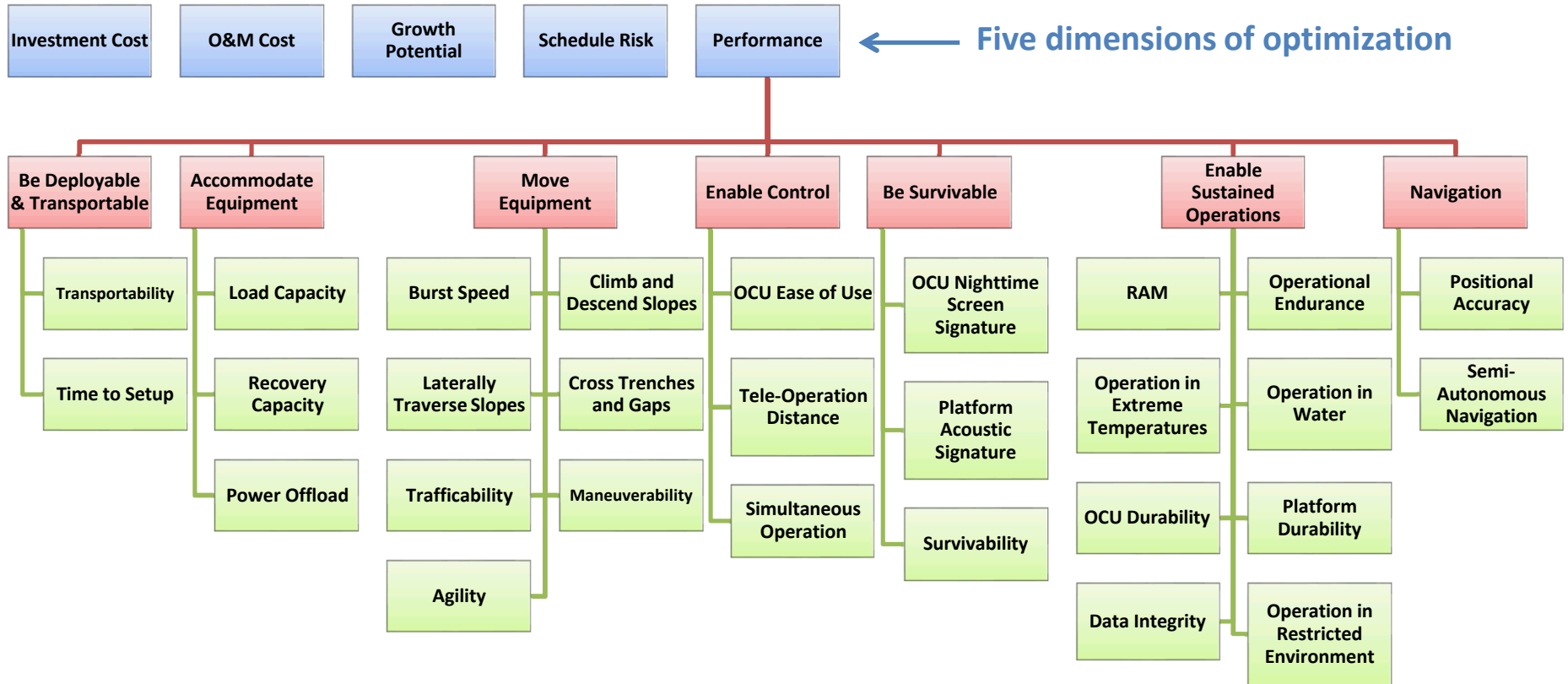



# SMET Product Structure

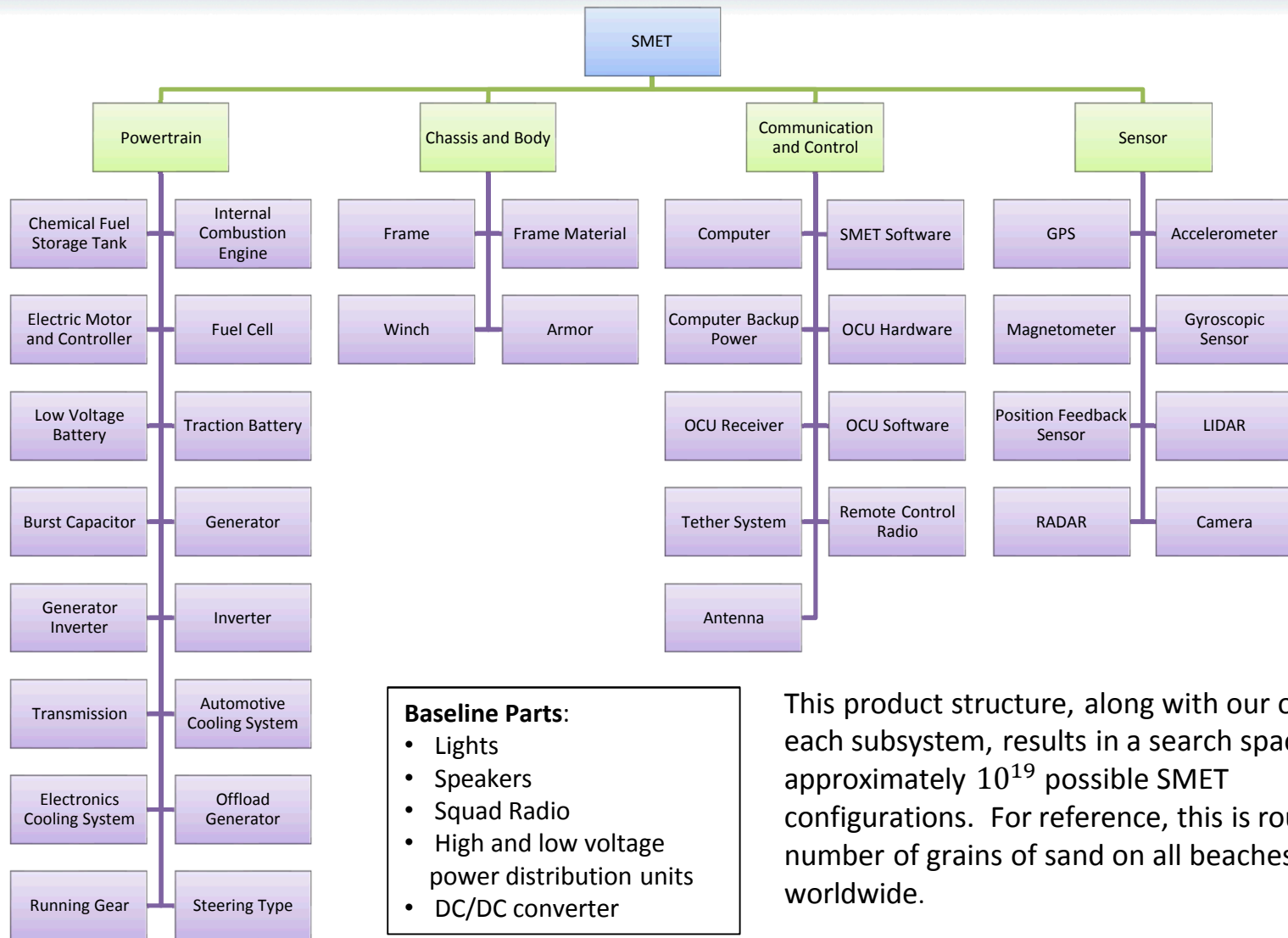

This product structure, along with our options for each subsystem, results in a search space of approximately  $10^{19}$  possible SMET configurations. For reference, this is roughly the number of grains of sand on all beaches worldwide.



# Sample Tech Option Trades

## Chemical Fuel Storage Tanks



- Capacities of 6, 12, 13, 18, 20 gallon available
- Impacts ability of platform to meet operational range requirement
- Also impacts weight and stability measures

## Offload Generators



- Optional payload to provide offload grid power
- Options have power ratings ranging from 2 – 5 kW
- Options powered by diesel or JP-8

## Computer Backup Power (UPS)



- Options provide backup power for 4 – 15 minutes at full load
- Impacts ability of platform to back up important data during an unexpected shutdown

## Winches



- Line pulls from 9000 – 12000 lbf available
- Impacts ability of platform to tow and recover other platforms
- All options are electrically powered



# Sample Tech Option Trades

## Generators



- Several options available in the 7 – 37 kW range
- Used in ICE only, series, and series parallel hybrid configurations
- Impacts power throughput, and mobility

## Generator Inverters



- Options are sized to condition & handle power output by the generator
- Impacts power throughput and mobility

## Electric Motors

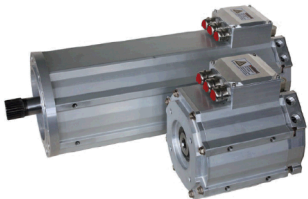

- Used in hybrid, electric propulsion, and fuel cell configurations
- Internal motor options provide 15 – 60 HP
- Hub motors are also traded (<10 HP per wheel) – affects sprung weight and mobility

## Inverters



- Used in all hybrid electric and fuel cell configurations
- Options are sized to handle incoming power to control motor
- Impacts power throughput and mobility



# SMET Power Flow Product Structure

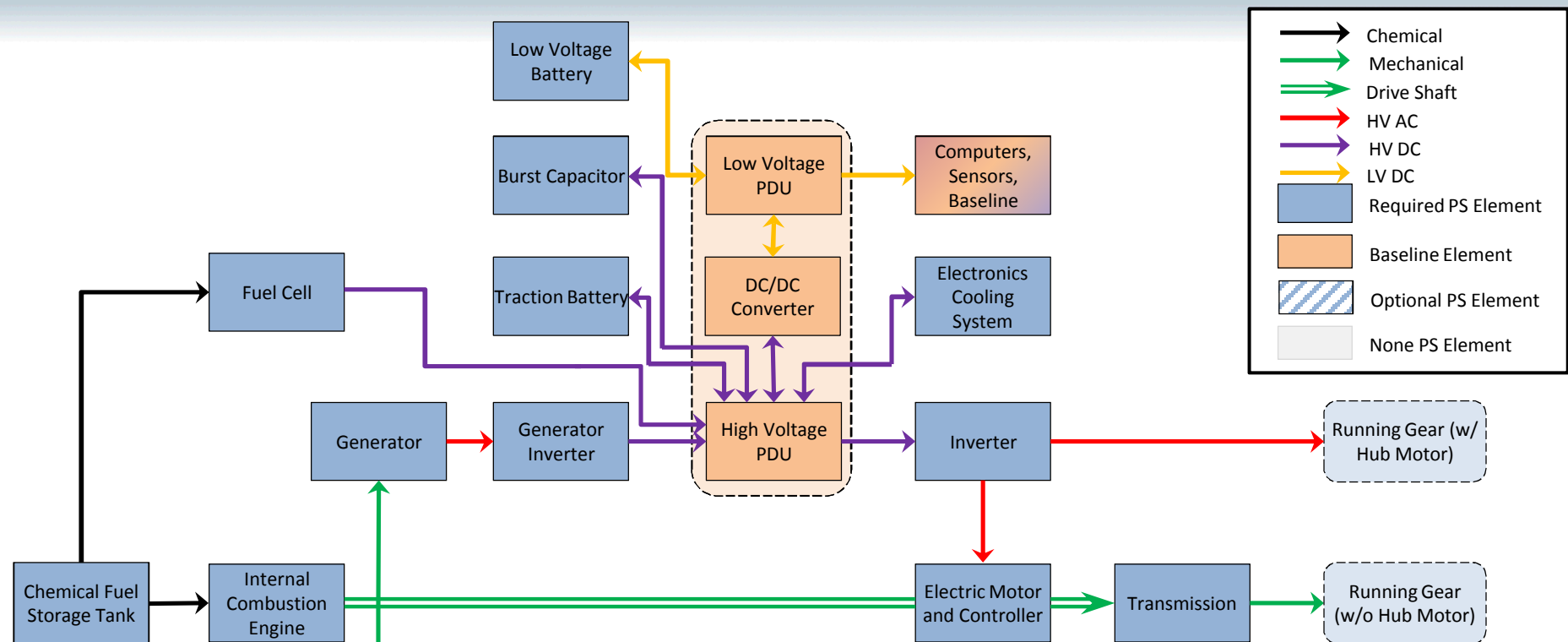

### Dependencies

- None Storage Tank **OBV** Fuel Cell, ICE
- Fuel Cell **NAND** ICE
- RG w/ Hub Motor **NAND** Electric Motor
- None Inverter **OBV** Electric Motor, RG w/ Hub Motor
- None Inverter **REQ** None Traction Battery, None Burst Cap, None Fuel Cell
- RG w/ Hub Motor **REQ** None Transmission
- RG w/o Hub Motor **OBV** None Transmission
- No ICE **OBV** ICE Only Transmission
- None Inverter **OBV** None Transmission, Gear Box, Complex Trans
- None Inverter **OBV** None ICE
- Motor **OBV** ICE Only Transmission
- Generator **OBV** None Generator Inverter
- None ICE **REQ** None Generator
- ICE **OBV** None Generator Inverter
- Generator Inverter **OBV** None ICE
- ICE **OBV** None Automotive Cooling System
- Automotive Cooling System **OBV** None ICE

### Attribute Constraints

- (ICE AND Inverter) **REQ** Traction Battery
- Storage Tank **REQ** (Fuel Cell OR ICE)
- Inverter **REQ** (Hub Motor OR Electric Motor)
- None ICE **REQ** (Fuel Cell OR Traction Battery)
- ICE **REQ** (Generator OR SR)
- ICE and (SN or SR) **IFF** Complex Hybrid Trans

### Electric Motor and Controller Types

- Single Reversible (SR)
- Single Nonreversible (SN)
- Multiple Nonreversible (MN)
- None

### Transmission Types

- ICE Transmission
- Simple Gear Box
- Complex Hybrid Transmission
- None



# Internal Combustion Only

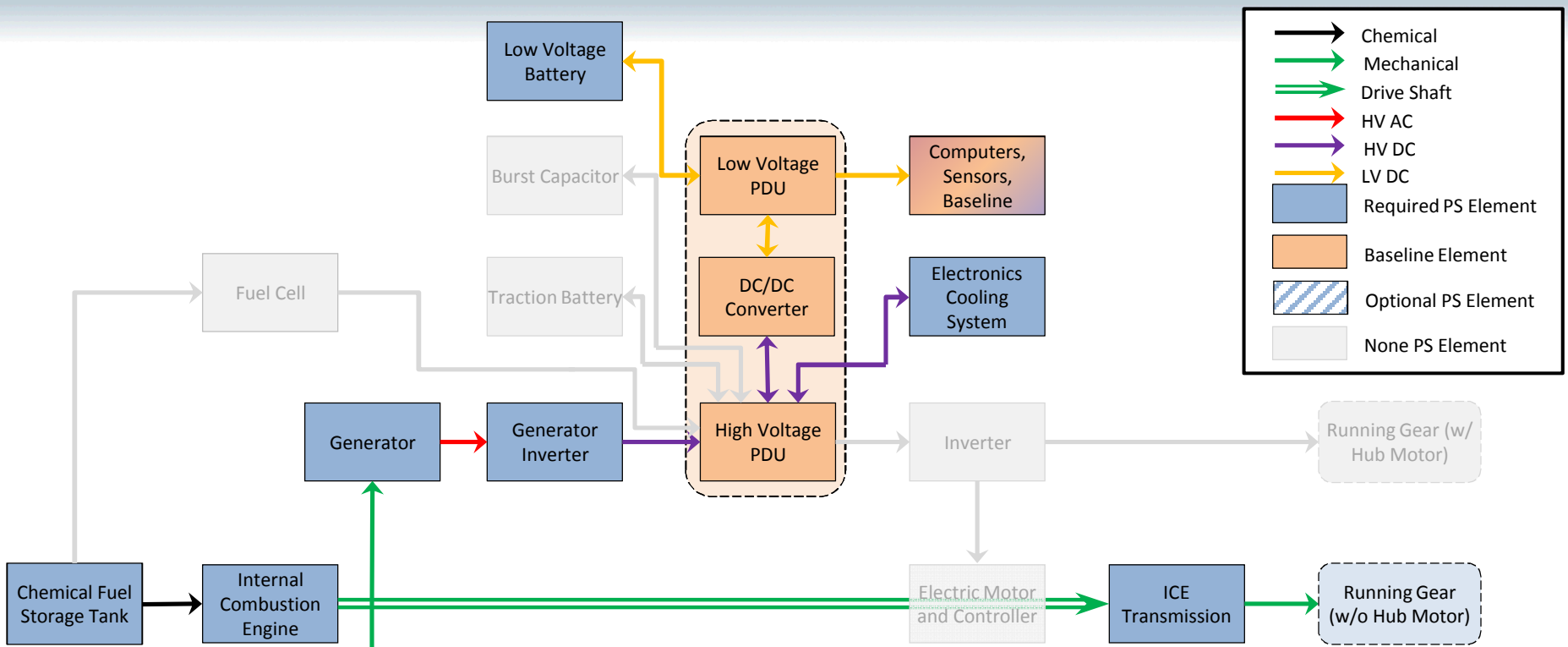

	Chemical
	Mechanical
	Drive Shaft
	HV AC
	HV DC
	LV DC
	Required PS Element
	Baseline Element
	Optional PS Element
	None PS Element

### Dependencies

- None Storage Tank **OBV** Fuel Cell, ICE
- Fuel Cell **NAND** ICE
- RG w/ Hub Motor **NAND** Electric Motor
- None Inverter **OBV** Electric Motor, RG w/ Hub Motor
- None Inverter **REQ** None Traction Battery, None Burst Cap, None Fuel Cell
- RG w/ Hub Motor **REQ** None Transmission
- RG w/o Hub Motor **OBV** None Transmission
- No ICE **OBV** ICE Only Transmission
- None Inverter **OBV** None Transmission, Gear Box, Complex Trans
- None Inverter **OBV** None ICE
- Motor **OBV** ICE Only Transmission
- Generator **OBV** None Generator Inverter
- None ICE **REQ** None Generator
- ICE **OBV** None Generator Inverter
- Generator Inverter **OBV** None ICE
- ICE **OBV** None Automotive Cooling System
- Automotive Cooling System **OBV** None ICE

### Attribute Constraints

- (ICE AND Inverter) **REQ** Traction Battery
- Storage Tank **REQ** (Fuel Cell OR ICE)
- Inverter **REQ** (Hub Motor OR Electric Motor)
- None ICE **REQ** (Fuel Cell OR Traction Battery)
- ICE **REQ** (Generator OR SR)
- ICE and (SN or SR) **IFF** Complex Hybrid Trans

### Electric Motor and Controller Types

- Single Reversible (SR)
- Single Nonreversible (SN)
- Multiple Nonreversible (MN)
- None

### Transmission Types

- ICE Transmission
- Simple Gear Box
- Complex Hybrid Transmission
- None



# All Electric

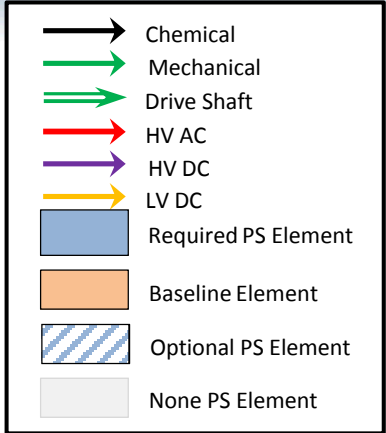
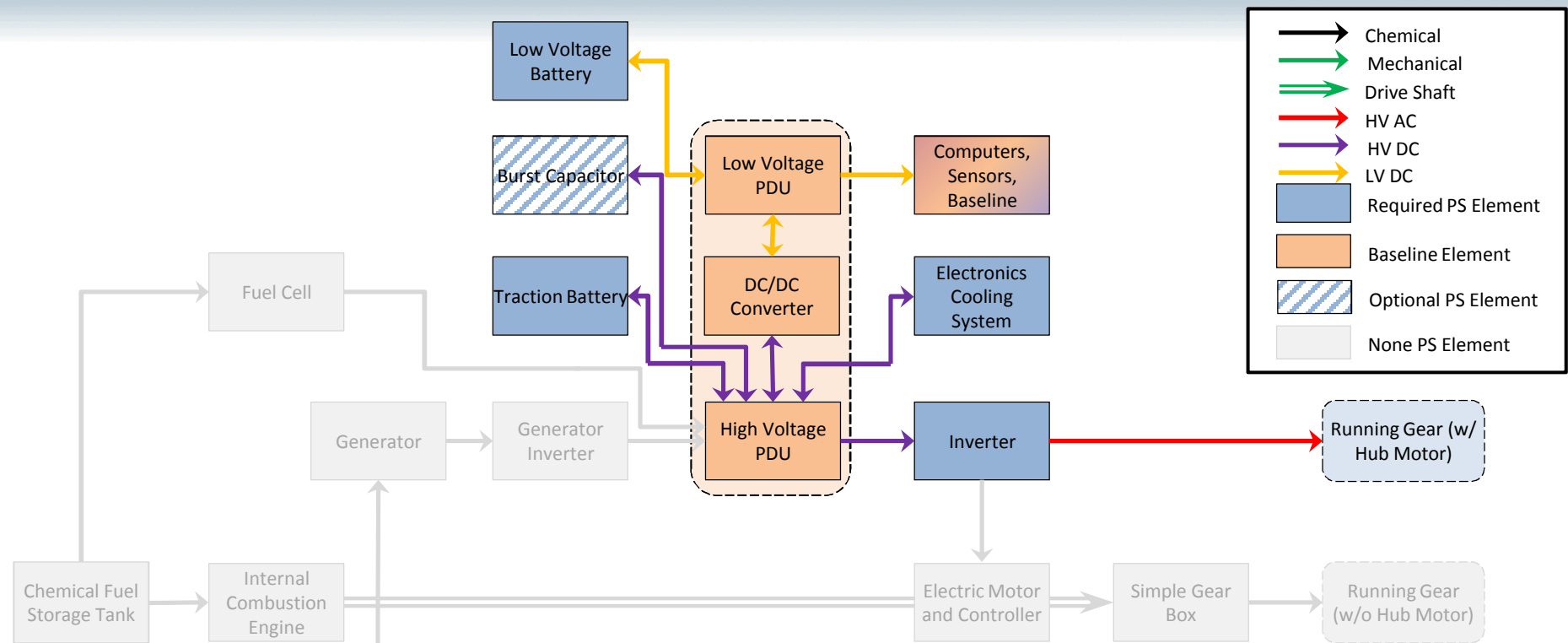

### Dependencies

- None Storage Tank **OBV** Fuel Cell, ICE
- Fuel Cell **NAND** ICE
- RG w/ Hub Motor **NAND** Electric Motor
- None Inverter **OBV** Electric Motor, RG w/ Hub Motor
- None Inverter **REQ** None Traction Battery, None Burst Cap, None Fuel Cell
- RG w/ Hub Motor **REQ** None Transmission
- RG w/o Hub Motor **OBV** None Transmission
- No ICE **OBV** ICE Only Transmission
- None Inverter **OBV** None Transmission, Gear Box, Complex Trans
- None Inverter **OBV** None ICE
- Motor **OBV** ICE Only Transmission
- Generator **OBV** None Generator Inverter
- None ICE **REQ** None Generator
- ICE **OBV** None Generator Inverter
- Generator Inverter **OBV** None ICE
- ICE **OBV** None Automotive Cooling System
- Automotive Cooling System **OBV** None ICE

### Attribute Constraints

- (ICE AND Inverter) **REQ** Traction Battery
- Storage Tank **REQ** (Fuel Cell OR ICE)
- Inverter **REQ** (Hub Motor OR Electric Motor)
- None ICE **REQ** (Fuel Cell OR Traction Battery)
- ICE **REQ** (Generator OR SR)
- ICE and (SN or SR) **IFF** Complex Hybrid Trans

### Electric Motor and Controller Types

- Single Reversible (SR)
- Single Nonreversible (SN)
- Multiple Nonreversible (MN)
- None

### Transmission Types

- ICE Transmission
- Simple Gear Box
- Complex Hybrid Transmission
- None



# All Electric

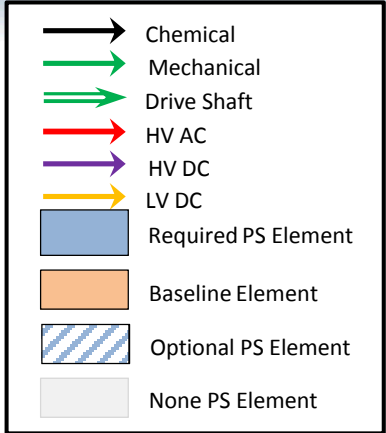
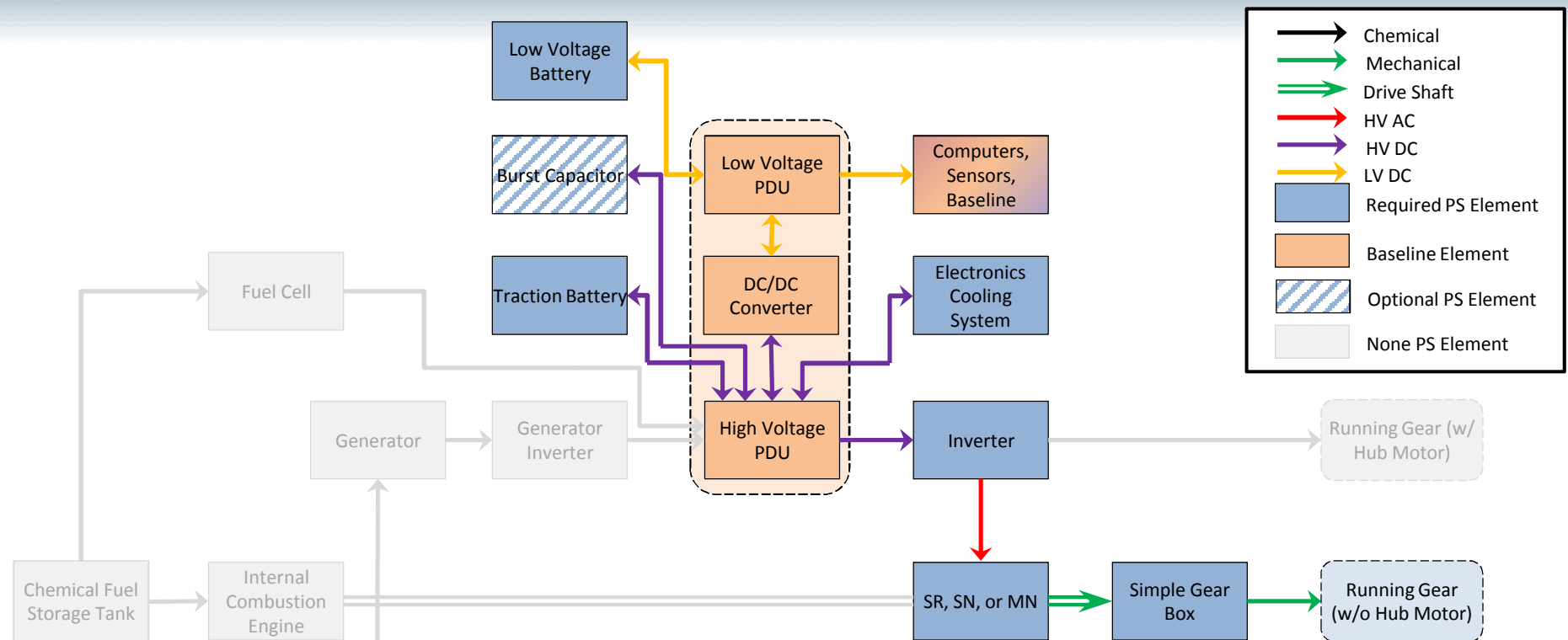

### Dependencies

- None Storage Tank **OBV** Fuel Cell, ICE
- Fuel Cell **NAND** ICE
- RG w/ Hub Motor **NAND** Electric Motor
- None Inverter **OBV** Electric Motor, RG w/ Hub Motor
- None Inverter **REQ** None Traction Battery, None Burst Cap, None Fuel Cell
- RG w/ Hub Motor **REQ** None Transmission
- RG w/o Hub Motor **OBV** None Transmission
- No ICE **OBV** ICE Only Transmission
- None Inverter **OBV** None Transmission, Gear Box, Complex Trans
- None Inverter **OBV** None ICE
- Motor **OBV** ICE Only Transmission
- Generator **OBV** None Generator Inverter
- None ICE **REQ** None Generator
- ICE **OBV** None Generator Inverter
- Generator Inverter **OBV** None ICE
- ICE **OBV** None Automotive Cooling System
- Automotive Cooling System **OBV** None ICE

### Attribute Constraints

- (ICE AND Inverter) **REQ** Traction Battery
- Storage Tank **REQ** (Fuel Cell OR ICE)
- Inverter **REQ** (Hub Motor OR Electric Motor)
- None ICE **REQ** (Fuel Cell OR Traction Battery)
- ICE **REQ** (Generator OR SR)
- ICE and (SN or SR) **IFF** Complex Hybrid Trans

### Electric Motor and Controller Types

- Single Reversible (SR)
- Single Nonreversible (SN)
- Multiple Nonreversible (MN)
- None

### Transmission Types

- ICE Transmission
- Simple Gear Box
- Complex Hybrid Transmission
- None



# Fuel Cell

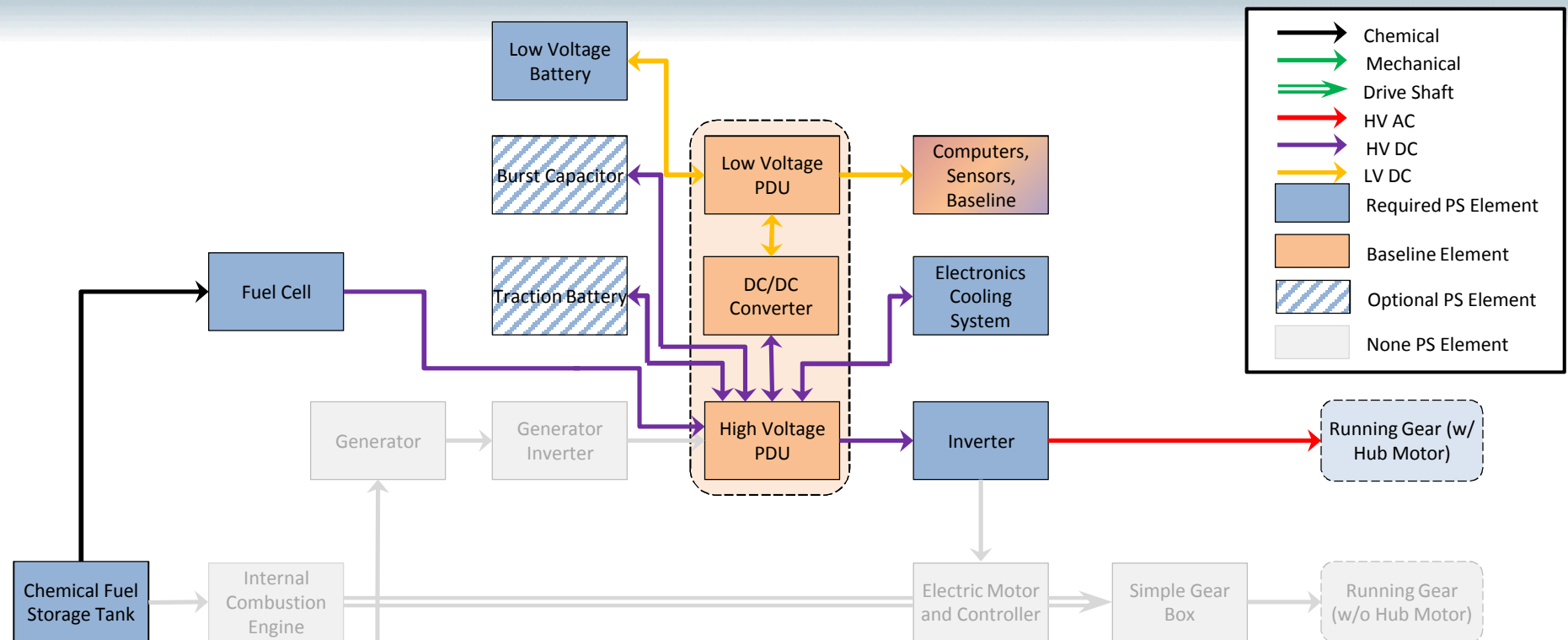

### Dependencies

- None Storage Tank **OBV** Fuel Cell, ICE
- Fuel Cell **NAND** ICE
- RG w/ Hub Motor **NAND** Electric Motor
- None Inverter **OBV** Electric Motor, RG w/ Hub Motor
- None Inverter **REQ** None Traction Battery, None Burst Cap, None Fuel Cell
- RG w/ Hub Motor **REQ** None Transmission
- RG w/o Hub Motor **OBV** None Transmission
- No ICE **OBV** ICE Only Transmission
- None Inverter **OBV** None Transmission, Gear Box, Complex Trans
- None Inverter **OBV** None ICE
- Motor **OBV** ICE Only Transmission
- Generator **OBV** None Generator Inverter
- None ICE **REQ** None Generator
- ICE **OBV** None Generator Inverter
- Generator Inverter **OBV** None ICE
- ICE **OBV** None Automotive Cooling System
- Automotive Cooling System **OBV** None ICE

### Attribute Constraints

- (ICE AND Inverter) **REQ** Traction Battery
- Storage Tank **REQ** (Fuel Cell OR ICE)
- Inverter **REQ** (Hub Motor OR Electric Motor)
- None ICE **REQ** (Fuel Cell OR Traction Battery)
- ICE **REQ** (Generator OR SR)
- ICE and (SN or SR) **IFF** Complex Hybrid Trans

### Electric Motor and Controller Types

- Single Reversible (SR)
- Single Nonreversible (SN)
- Multiple Nonreversible (MN)
- None

### Transmission Types

- ICE Transmission
- Simple Gear Box
- Complex Hybrid Transmission
- None



# Series-Parallel Hybrid

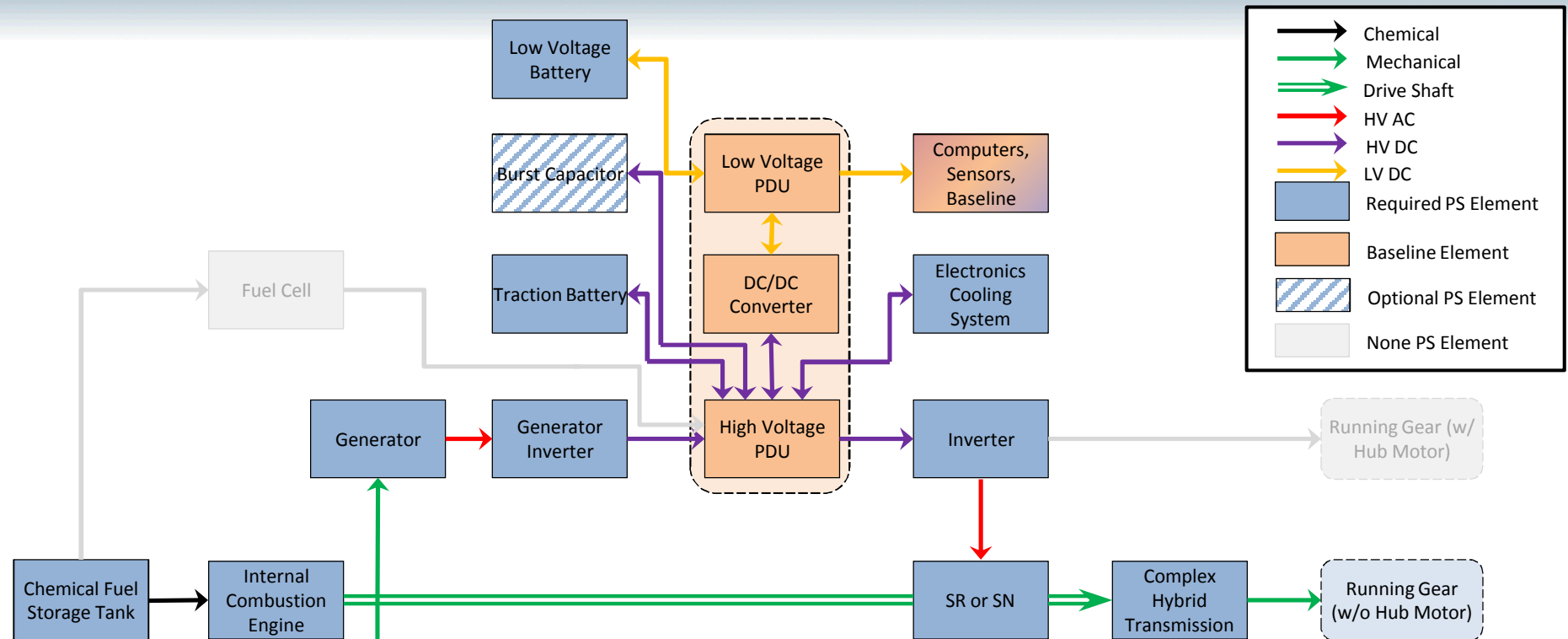

### Dependencies

- None Storage Tank **OBV** Fuel Cell, ICE
- Fuel Cell **NAND** ICE
- RG w/ Hub Motor **NAND** Electric Motor
- None Inverter **OBV** Electric Motor, RG w/ Hub Motor
- None Inverter **REQ** None Traction Battery, None Burst Cap, None Fuel Cell
- RG w/ Hub Motor **REQ** None Transmission
- RG w/o Hub Motor **OBV** None Transmission
- No ICE **OBV** ICE Only Transmission
- None Inverter **OBV** None Transmission, Gear Box, Complex Trans
- None Inverter **OBV** None ICE
- Motor **OBV** ICE Only Transmission
- Generator **OBV** None Generator Inverter
- None ICE **REQ** None Generator
- ICE **OBV** None Generator Inverter
- Generator Inverter **OBV** None ICE
- ICE **OBV** None Automotive Cooling System
- Automotive Cooling System **OBV** None ICE

### Attribute Constraints

- (ICE AND Inverter) **REQ** Traction Battery
- Storage Tank **REQ** (Fuel Cell OR ICE)
- Inverter **REQ** (Hub Motor OR Electric Motor)
- None ICE **REQ** (Fuel Cell OR Traction Battery)
- ICE **REQ** (Generator OR SR)
- ICE and (SN or SR) **IFF** Complex Hybrid Trans

### Electric Motor and Controller Types

- Single Reversible (SR)
- Single Nonreversible (SN)
- Multiple Nonreversible (MN)
- None

### Transmission Types

- ICE Transmission
- Simple Gear Box
- Complex Hybrid Transmission
- None



# Parallel Hybrid

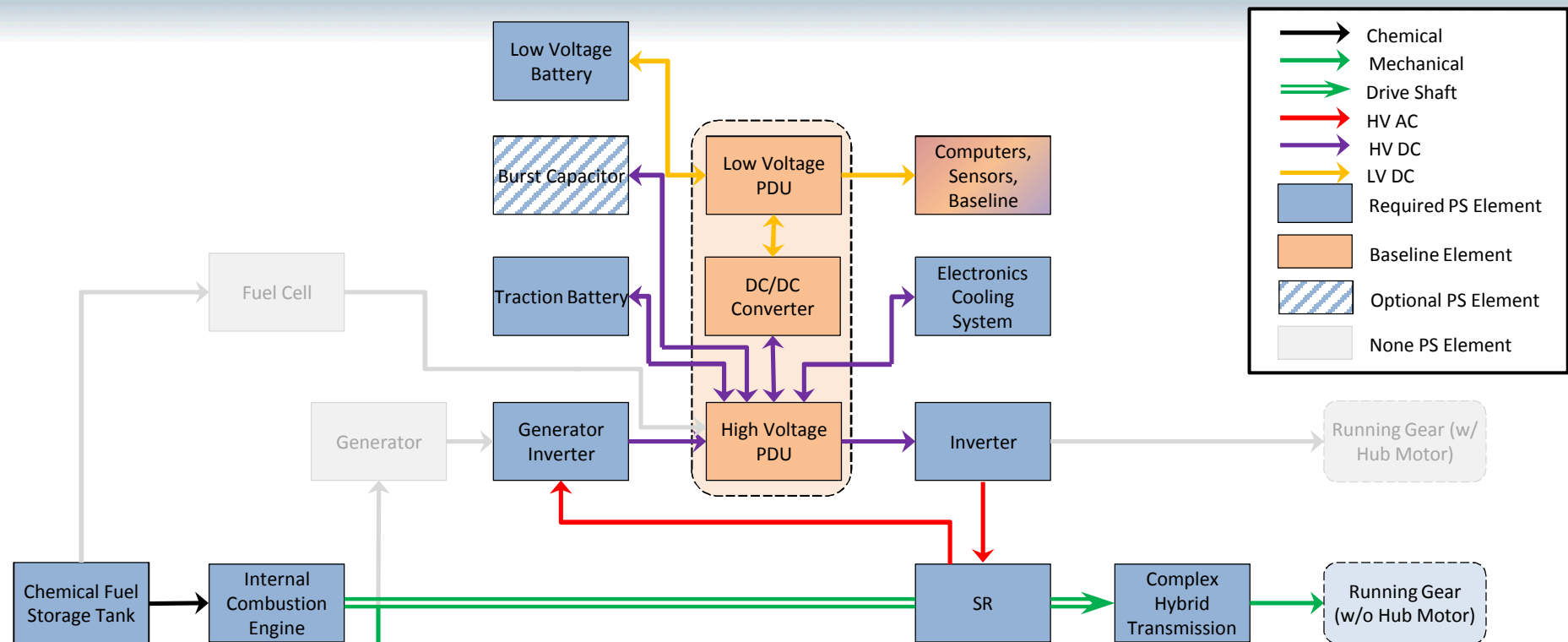

	Chemical
	Mechanical
	Drive Shaft
	HV AC
	HV DC
	LV DC
	Required PS Element
	Baseline Element
	Optional PS Element
	None PS Element

### Dependencies

- None Storage Tank **OBV** Fuel Cell, ICE
- Fuel Cell **NAND** ICE
- RG w/ Hub Motor **NAND** Electric Motor
- None Inverter **OBV** Electric Motor, RG w/ Hub Motor
- None Inverter **REQ** None Traction Battery, None Burst Cap, None Fuel Cell
- RG w/ Hub Motor **REQ** None Transmission
- RG w/o Hub Motor **OBV** None Transmission
- No ICE **OBV** ICE Only Transmission
- None Inverter **OBV** None Transmission, Gear Box, Complex Trans
- None Inverter **OBV** None ICE
- Motor **OBV** ICE Only Transmission
- Generator **OBV** None Generator Inverter
- None ICE **REQ** None Generator
- ICE **OBV** None Generator Inverter
- Generator Inverter **OBV** None ICE
- ICE **OBV** None Automotive Cooling System
- Automotive Cooling System **OBV** None ICE

### Attribute Constraints

- (ICE AND Inverter) **REQ** Traction Battery
- Storage Tank **REQ** (Fuel Cell OR ICE)
- Inverter **REQ** (Hub Motor OR Electric Motor)
- None ICE **REQ** (Fuel Cell OR Traction Battery)
- ICE **REQ** (Generator OR SR)
- ICE and (SN or SR) **IFF** Complex Hybrid Trans

### Electric Motor and Controller Types

- Single Reversible (SR)
- Single Nonreversible (SN)
- Multiple Nonreversible (MN)
- None

### Transmission Types

- ICE Transmission
- Simple Gear Box
- Complex Hybrid Transmission
- None



# Series Hybrid

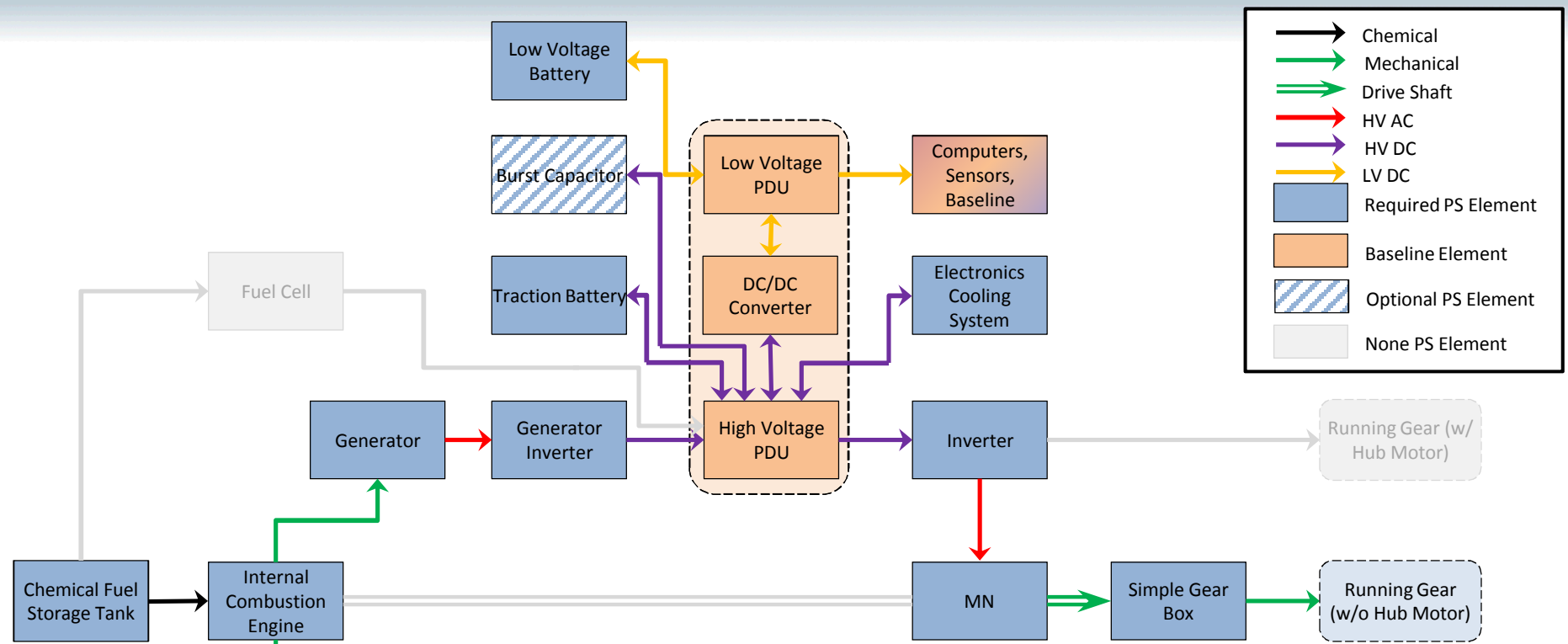

### Dependencies

- None Storage Tank **OBV** Fuel Cell, ICE
- Fuel Cell **NAND** ICE
- RG w/ Hub Motor **NAND** Electric Motor
- None Inverter **OBV** Electric Motor, RG w/ Hub Motor
- None Inverter **REQ** None Traction Battery, None Burst Cap, None Fuel Cell
- RG w/ Hub Motor **REQ** None Transmission
- RG w/o Hub Motor **OBV** None Transmission
- No ICE **OBV** ICE Only Transmission
- None Inverter **OBV** None Transmission, Gear Box, Complex Trans
- None Inverter **OBV** None ICE
- Motor **OBV** ICE Only Transmission
- Generator **OBV** None Generator Inverter
- None ICE **REQ** None Generator
- ICE **OBV** None Generator Inverter
- Generator Inverter **OBV** None ICE
- ICE **OBV** None Automotive Cooling System
- Automotive Cooling System **OBV** None ICE

### Attribute Constraints

- (ICE AND Inverter) **REQ** Traction Battery
- Storage Tank **REQ** (Fuel Cell OR ICE)
- Inverter **REQ** (Hub Motor OR Electric Motor)
- None ICE **REQ** (Fuel Cell OR Traction Battery)
- ICE **REQ** (Generator OR SR)
- ICE and (SN or SR) **IFF** Complex Hybrid Trans

### Electric Motor and Controller Types

- Single Reversible (SR)
- Single Nonreversible (SN)
- Multiple Nonreversible (MN)
- None

### Transmission Types

- ICE Transmission
- Simple Gear Box
- Complex Hybrid Transmission
- None



# Sample SMET FO: Power Offload

## Input

- Power Rating (kW) – Off. Generator, Fuel Cell, Generator, Gen. Inverter, Inverter
- Power (HP) – Internal Combustion Engine, Electric Motor
- Efficiency (%) – Generator, Gen. Inverter, Inverter

## Calculated Intermediate Parameters

- SMET Drive Type

## Input Constants

- HVPDU Efficiency (%)

If SMET Drive Type = 'Hybrid 2'

MechToAC Efficiency (%) = Electric Motor and Controller Generator Efficiency (%)

MechToAC Power Rating (kW) = Electric Motor and Controller Power (hp) \* 0.746 (kW/hp)

Else

MechToAC Efficiency (%) = Generator Efficiency (%)

MechToAC Power Rating (kW) = Generator Power Rating (kW)

Power Available to Generator (kW) = Internal Combustion Engine Power (hp) \* 0.746 (kW/hp)

Power Available to Generator Inverter (kW) = min(Power Available to Generator (kW) \* MechToAC Efficiency (%), MechToAC Power Rating (kW))

Power Available to Inverter (kW) = min(Power Available to Generator Inverter (kW) \* Generator Inverter Efficiency (%),  
Generator Inverter Power Rating (kW)) \* HVPDU Efficiency (%)

Power Offload from Internal Generator (kW) = min(Power Available to Inverter (kW) \* Inverter Efficiency (%), Inverter Power Rating (kW))

Power Offload from External Generator (kW) = Offload Generator Power Rating (kW)

Power Offload from Fuel Cell (kW) = min(Fuel Cell Power Rating (kW) \* HVPDU Efficiency (%) \* Inverter Efficiency (%), Inverter Power Rating (kW))

Power Offload (kW) = Power Offload from Internal Generator (kW) + Power Offload from External Generator (kW) + Power Offload from Fuel Cell (kW)

## Assumptions

- Evaluated while S-MET is stationary and sensors are off
- The internal S-MET generator must send its power through the Generator Inverter, PDU, and Inverter in order to clean its signal before sending to the base
- The Fuel Cell sends its DC power through the PDU and inverted to be converted to AC for the base

## Output

- Power Offload (kW)



# Additional SMET Metrics

## Dimension Metrics

Running Gear Width (in)  
Running Gear Track Length (in)  
Underbody Axle Mount Height (in)  
SMET Ground Clearance (in)  
Back Deck Overhang (in)  
Front Deck Overhang (in)  
SMET Climb Height (in)  
SMET FCC Height (in)  
SMET FCC Horizontal COG  
SMET FCC Length (in)  
SMET FCC Vertical COG  
SMET FCC Width (in)  
SMET FCC Curb-to-Curb Turning Diameter (in)  
SMET Platform Height (in)  
SMET Platform Length (in)  
SMET Platform Width (in)  
Upper Cargo Storage Height (in)  
Upper Cargo Storage Length (in)  
Upper Cargo Storage Width (in)

## Cost Metrics

Frame Cost (\$)  
Running Gear Cost (\$)

## Power Flow Metrics

Automotive Cooling Power Draw (kW)  
Baseline Electronics Heat Generation (kW)  
Electronics Cooling Power Draw (kW)  
Electronics Steady State Power Draw (kW)  
Sprocket Power Available Burst Mode (kW)  
Sprocket Power Available from Fuel Cell or Battery Endurance Mode (kW)  
Sprocket Power Available from ICE Endurance Mode (kW)  
Sprocket Power Required Endurance Mode (kW)

## Weight Metrics

Frame Weight (lbs)  
Running Gear Sprung Weight (lbs)  
Running Gear Weight (lbs)  
Running Gear Weight Limit (lbs)  
SMET FCC Front Weight (lbs)  
SMET FCC Internal Component Weight (lbs)  
SMET FCC Sprung Weight (lbs)  
SMET FCC Under Deck Weight (lbs)  
SMET FCC Weight (lbs)  
Total FCC Load Weight (lbs)  
SMET Platform Sprung Weight (lbs)  
SMET Platform Weight (lbs)

## Surface Area Metrics

Overbody Protectable Surface Area (in<sup>2</sup>)  
Underbody Protectable Surface Area (in<sup>2</sup>)  
Running Gear Contact Patch Area (in<sup>2</sup>)

## Volume Metrics

Frame Material Used (in<sup>3</sup>)  
Internal Component Volume (in<sup>3</sup>)  
Internal Frame Volume (in<sup>3</sup>)  
Lower Cargo Storage Volume (in<sup>3</sup>)  
SMET Internal Volume Ratio  
Total FCC Load Volume (in<sup>3</sup>)

## Misc Metrics

Running Gear MTBF (hrs)  
Running Gear Number of Road Wheels  
SMET Drive Type  
SMET Fuel Type



# Aggregating FOs for Optimization

- Recall that an SMET configuration's Performance Score represents an aggregation of 28 diverse performance FOs.
- WSTAT maps each of the 28 "raw" performance FO values into a common 0 to 100 utility score.

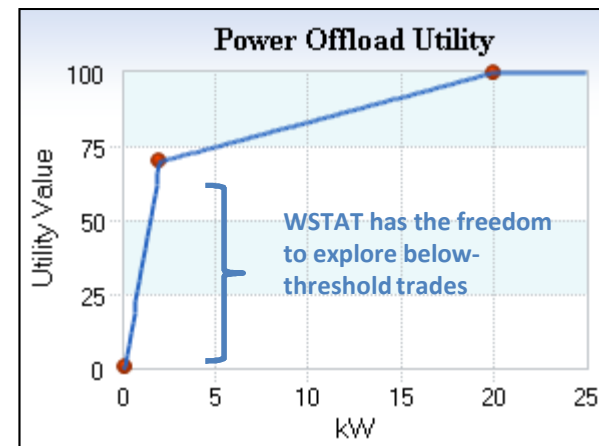
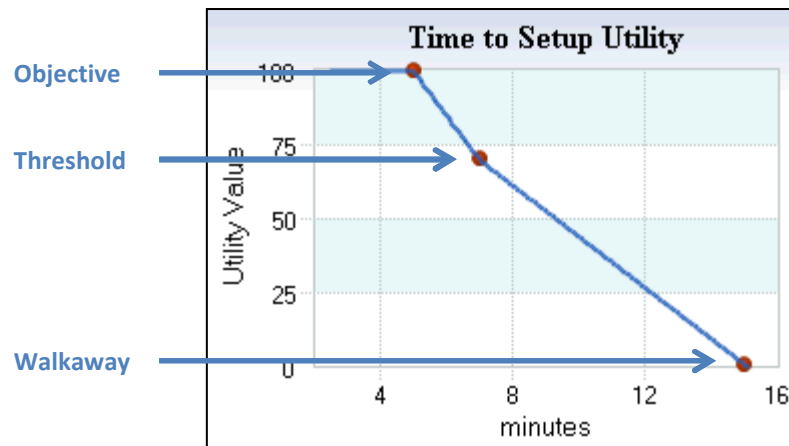

- This mapping allows for
  - an apples-to-apples comparison between different FO scores, and
  - a means by which to take a weighted sum to combine the 28 FO scores into a single Performance Score.



# FO Priority Weighting

To form a weighted sum of the 28 performance FO utility scores, priority weights were elicited from SMET users and experts using the Swing Weight Matrix method during an in-person panel.

Functional Objective	User Priority Weight
RAM (Reliability/Availability/Maintainability)	0.1224
Platform Acoustic Signature	0.1224
Load Capacity	0.0586
Climb and Descend Slopes	0.0586
Laterally Traverse Slopes	0.0586
Maneuverability	0.0586
Cross Trenches and Gaps	0.0586
Trafficability	0.0586
Operation in Extreme Temperatures	0.0586
Tele-Operation Distance	0.0586
Survivability	0.0357
Operational Endurance	0.0269
Operation in Restricted Environment	0.0269
OCU Durability	0.0269
OCU Ease of Use	0.0269
Simultaneous Operations	0.0269
Agility	0.0175
Operation in Water	0.0175
Platform Durability	0.0175
Transportability	0.0101
Time to Setup	0.0101
Recovery Capacity	0.0101
Power Offload	0.0101
Data Integrity	0.0101
Positional Accuracy	0.0047
Semi-Autonomous Navigation	0.0047
Burst Speed	0.0019
OCU Nighttime Screen Brightness	0.0019

		Level of Importance		
		Defining Capability	Critical Capability	Enabling / Enhancing Capability
Level of Variation across Trade Space	High Differentiation	Highest Weight		
	Moderate Differentiation			
	Low Differentiation			Lowest Weight

Swing Weight Matrix



# SMET WSTAT Emerging Results

DISCLAIMER: These are emerging results derived from evolving CDD requirements and Technology data. Results could change as data matures.

Reference herein to any specific commercial company, product, process, or service by trade name, trademark, manufacturer, or otherwise, does not necessarily constitute or imply its endorsement, recommendation, or favoring by the United States Government or the Department of the Army (DoA). The opinions of the authors expressed herein do not necessarily state or reflect those of the United States Government or the DoA, and shall not be used for advertising or product endorsement purposes.



# Cost-Performance Trade Space

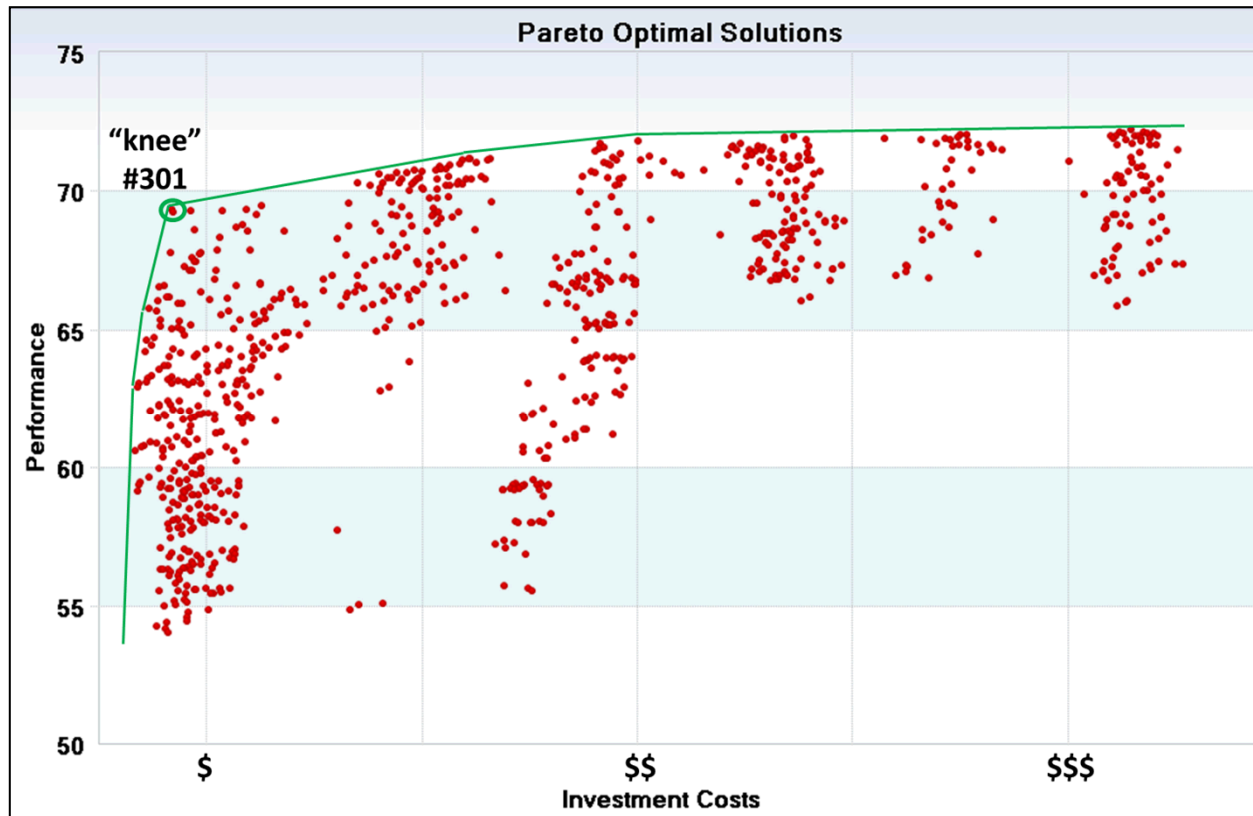

- Every dot represents an optimal SMET configuration
- Solutions further from the cost-performance "bleed edge" provide good tradeoffs in the other 3 dimensions (O&M Cost, Growth, Risk)
- The "knee" in the cost-performance trade space occurs towards the cheap end
- Beyond this knee, marginal performance gains per dollar spent



# Cost-Performance Trade Space (by Running Gear)

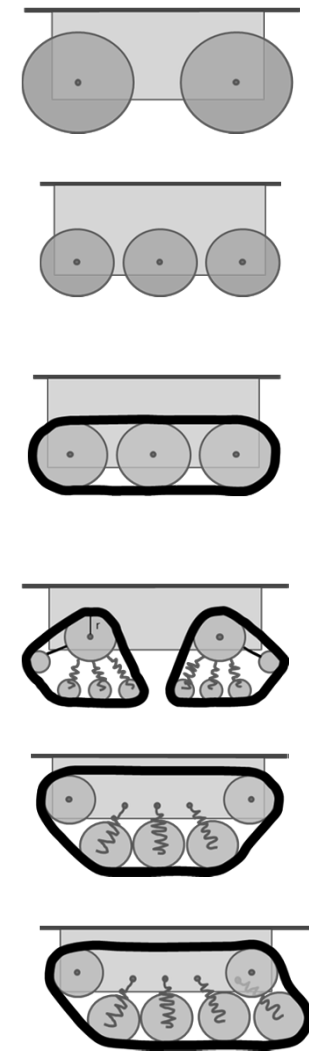
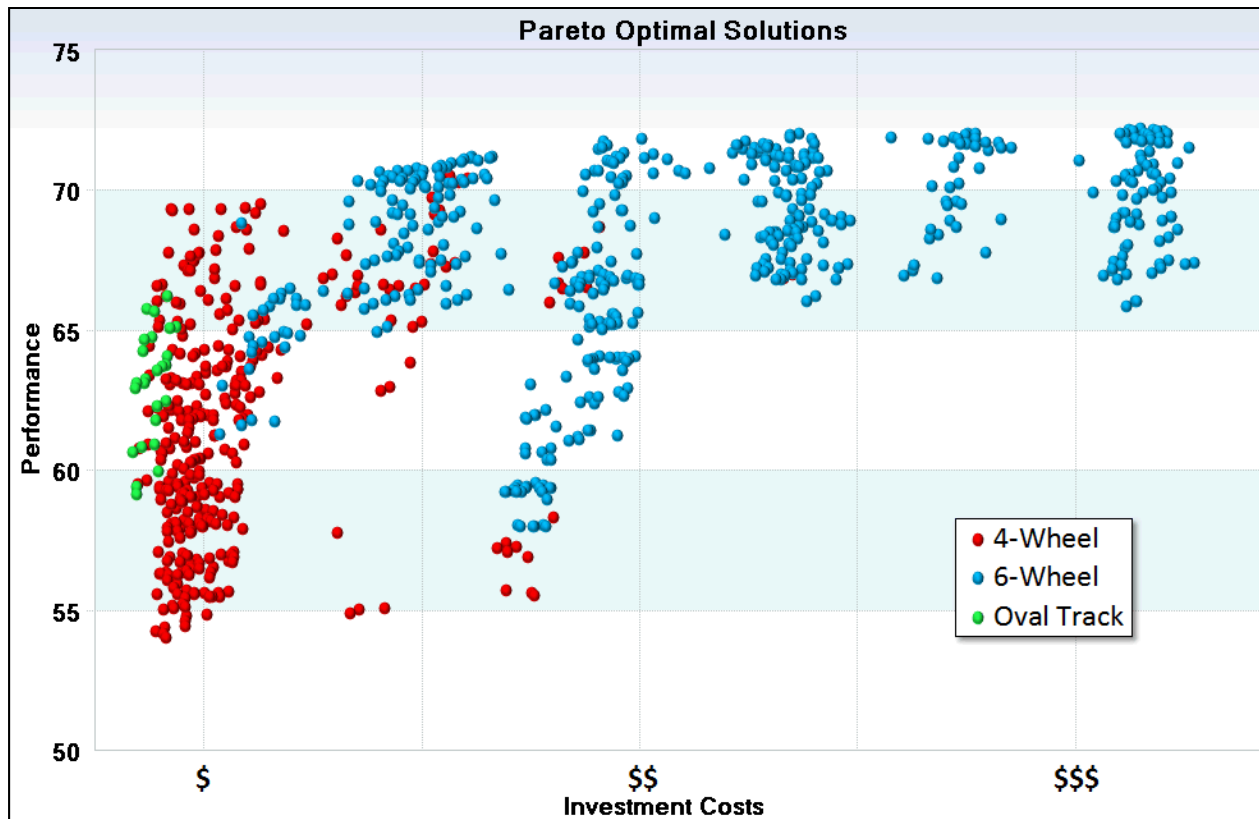

- Highlighting the trade space by choice of Running Gear type shows where certain design choices do (and don't) make sense



# Cost-Performance Trade Space (by Propulsion)

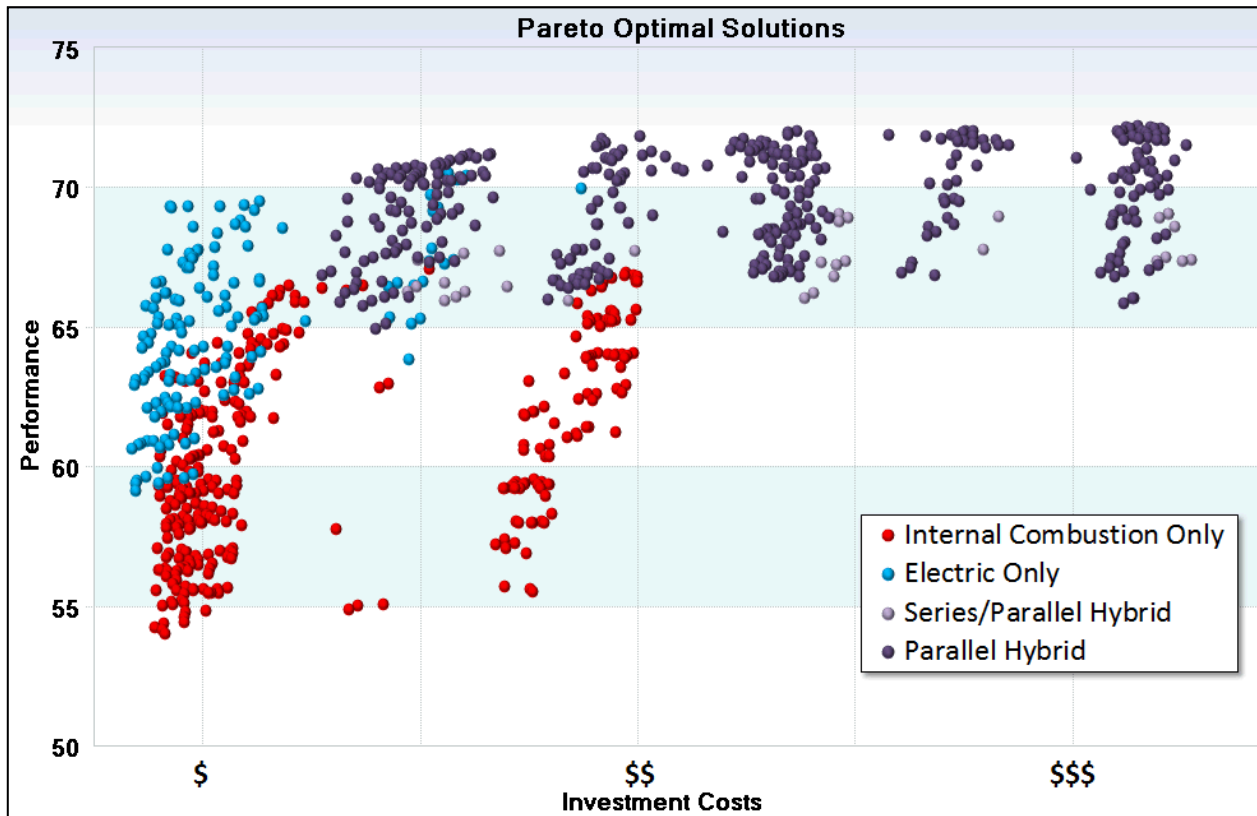

- Highlighting the trade space by choice of Propulsion architecture also informs critical design decisions

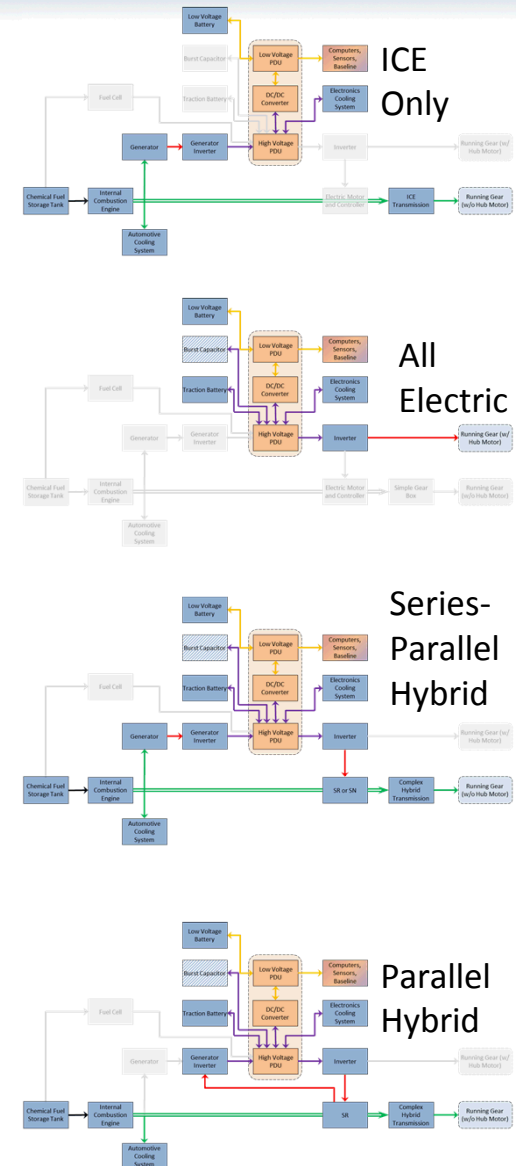



# Weight-Performance Trade Space

We can generate plots showing any tradeoff amongst various Optimization dimensions, individual FOs, and Metrics. Here we show Performance (Dimension) vs Platform Weight (Metric).

## #319 “Nimble”

- All Electric
- No Engine
- Smaller Batteries
- 4-Wheeled
- Small Carbon Fiber Frame
- Light Composite armor
- No Computer Backup PSU

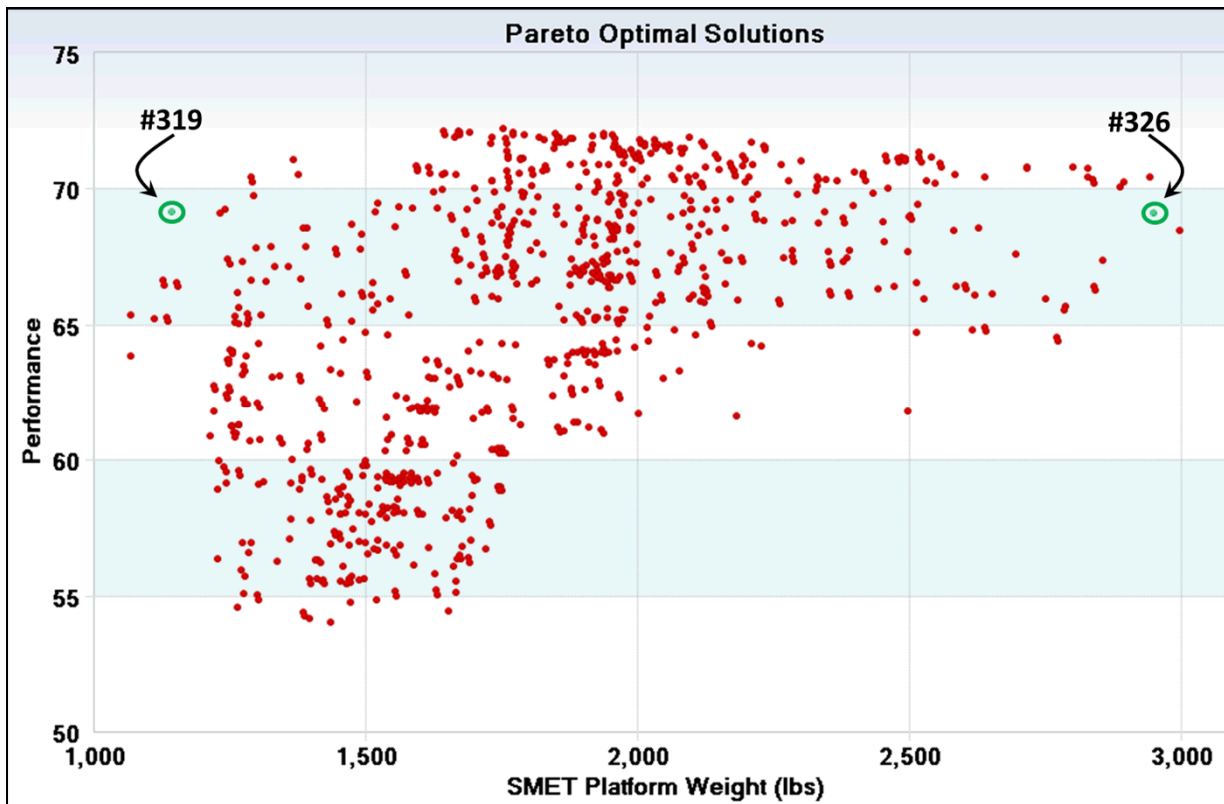

## #326 “Heavy”

- Parallel Hybrid
- 44HP Engine
- Larger Batteries
- 6-Wheeled
- Large Steel Frame
- Heavy Steel armor
- 800W Computer Backup PSU

Both configurations have nearly identical overall performance, but they achieve this performance in very different ways. WSTAT lets us compare these differences in detail.



# Nimble vs. Heavy

We can generate plots showing any tradeoff amongst various Optimization dimensions, individual FOs, and Metrics. Here we show Performance (Dimension) vs Platform Weight (Metric).

## #319 "Nimble"

- All Electric
- No Engine
- Smaller Batteries
- 4-Wheeled
- Small Carbon Fiber Frame
- Light Composite armor
- No Computer Backup PSU

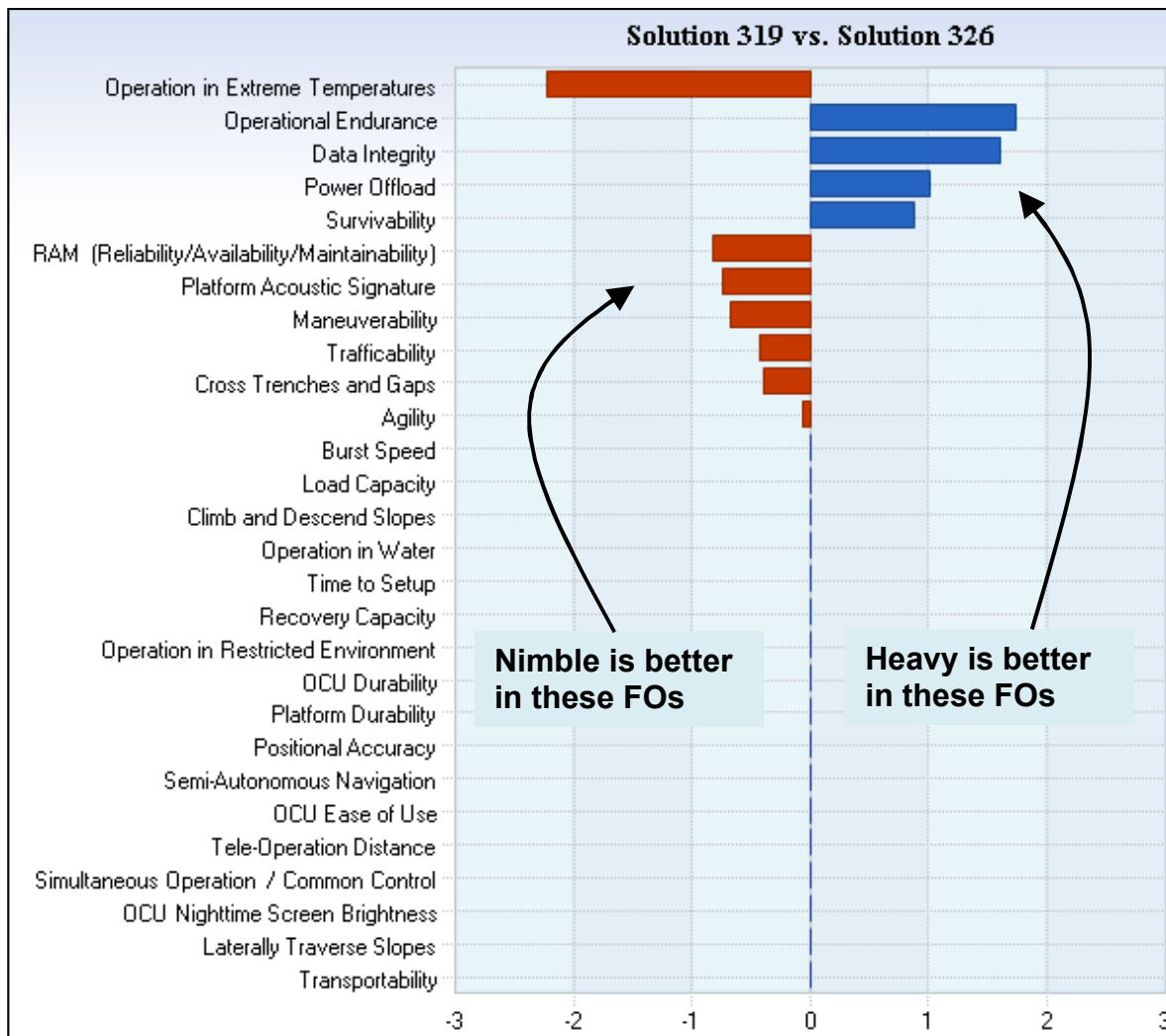

## #326 "Heavy"

- Parallel Hybrid
- 44HP Engine
- Larger Batteries
- 6-Wheeled
- Large Steel Frame
- Heavy Steel armor
- 800W Computer Backup PSU



# Autonomy Study

We noticed that autonomy hardware was never selected for any solution in the optimal trade space. As one avenue of investigation, we can manually “clone” a solution, add autonomy technologies, and examine the resulting FOs.

## #301 “Baseline”

- All Electric
- Large Batteries
- 4-Wheeled
- No Autonomy Hardware

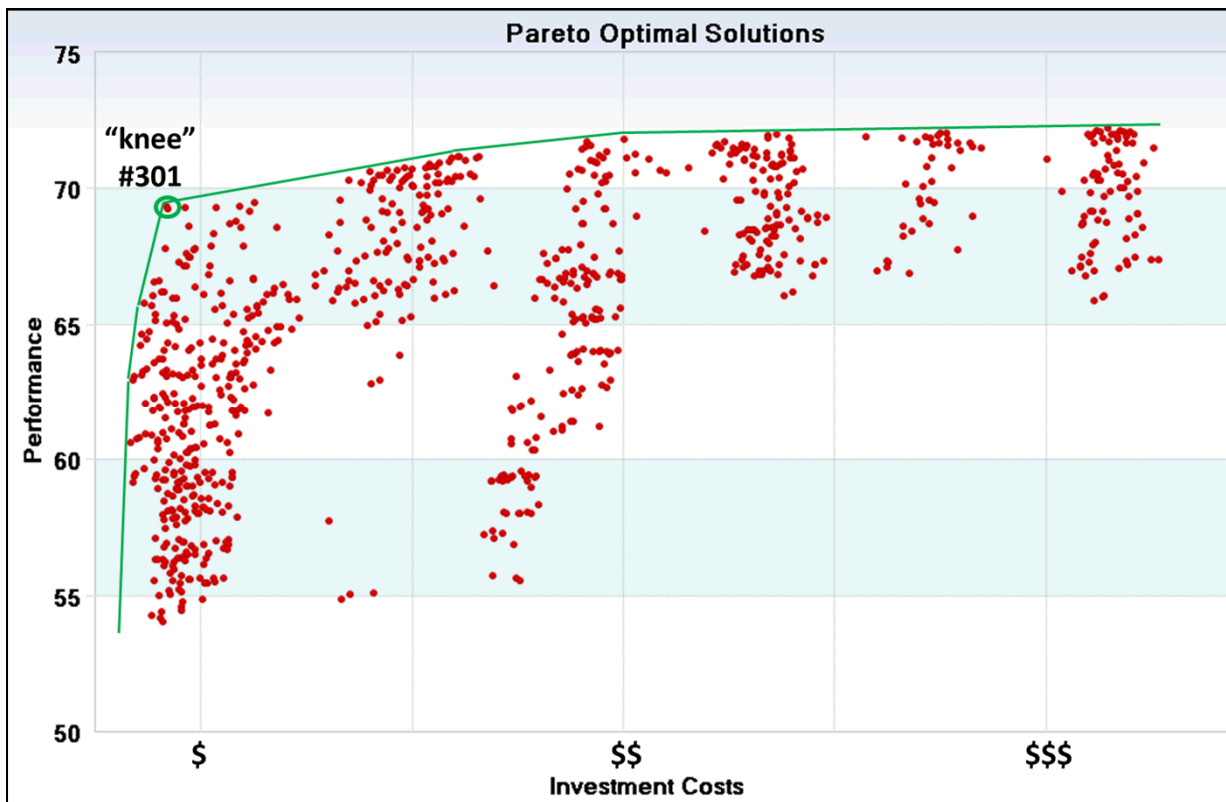

## #301-A “Marvin”

- All Electric
- Large Batteries
- 4-Wheeled
- Upgraded Computer
- LIDAR (front & back)
- Vision Cameras (front & back)

Now we can compare Baseline vs Marvin and see where the FOs differ. Marvin should have a much better Autonomy FO score, but how will it trade off with other FOs?



# Autonomy Study

We noticed that autonomy hardware was never selected for any solution in the optimal trade space. As one avenue of investigation, we can manually “clone” a solution, add autonomy technologies, and examine the resulting FOs.

## #301 “Baseline”

- All Electric
- Large Batteries
- 4-Wheeled
- **No Autonomy Hardware**

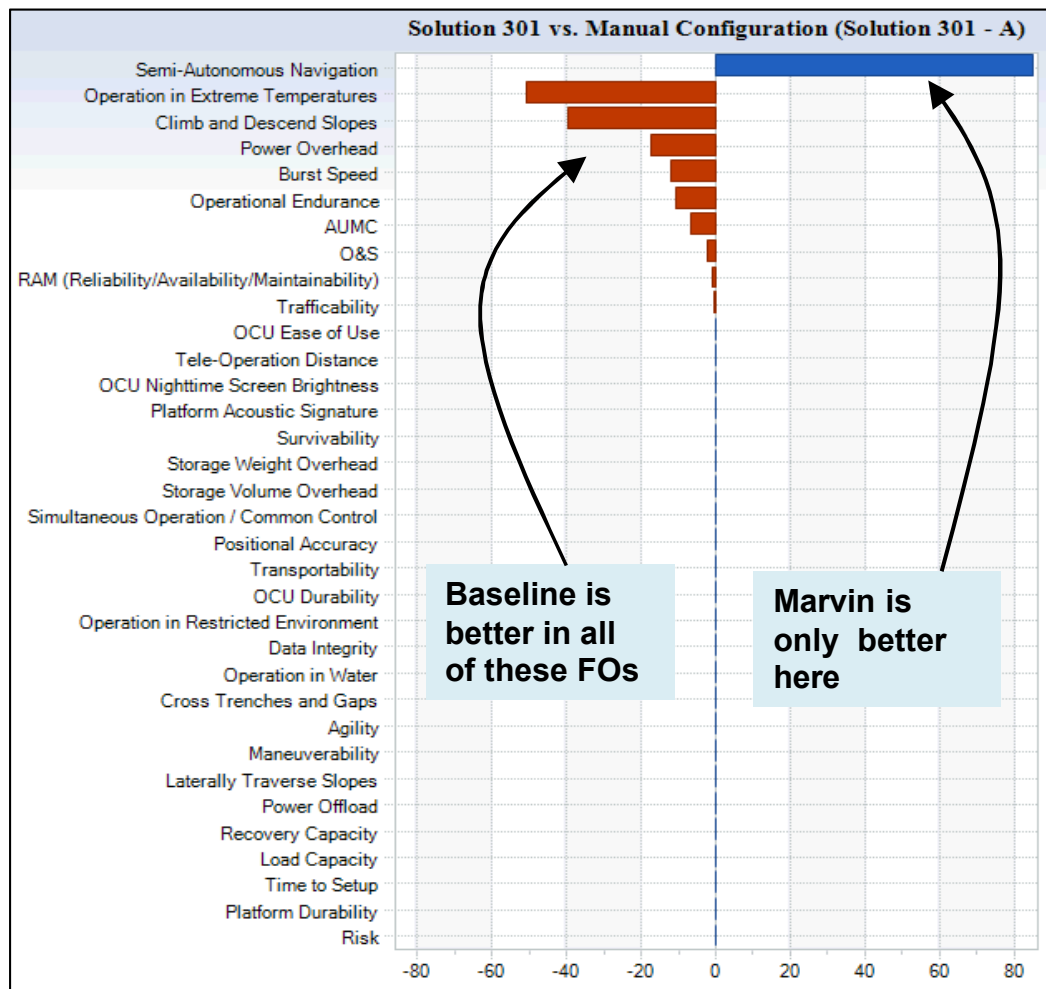

## #301-A “Marvin”

- All Electric
- Large Batteries
- 4-Wheeled
- **Upgraded Computer**
- **LIDAR (front & back)**
- **Vision Cameras (front & back)**



# Other WSTAT Use Cases and Capabilities

- Requirements analysis
- Tradeoff Analysis (between technologies, requirements, attributes)
- Parametric analysis
- Family analysis



# Acknowledgements / Q&A



## Study Sponsor: LTC Cory Berg



- **PEO GCS Analytics**

- Mike DiNunzio

- **Sandia National Labs**

- Stephen Henry
- Lucas Waddell
- Darryl Melander
- Adam Pierson
- Geoff Pankretz

- **Booz Allen Hamilton**

- James Ealy
- Ryan Pykor
- Mike Zabat
- Katherine Spencer

### **Technical SME Contributors**

- Micah Baker (ALUGS)
- LTC Berg (PM FP Robotics)
- Patric Bickle (ALUGS)
- Sanjiv Dungrani (ALUGS)
- Philip Frederick (TARDEC)
- Lonnie Freiburger (TARDEC)

- Ed Lundstrom (ALUGS)
- Scott Lohrer (ALUGS M&S)
- John Niemeyer (TARDEC)
- Todd Willert (TARDEC)
- Keith Briggs (TARDEC)
- Matt Deminico (TARDEC)

- Dave Conger (TARDEC)
- George Hamilton (TARDEC)
- Dean McGrew (TARDEC)
- Kevin Centeck (TARDEC)
- Darin Kowalski (TARDEC)