

Aluminized  
propellant

SAND2016-6912C

# Temperature and oxygen measurements in a metallized propellant flame by hybrid fs/ps rotational CARS

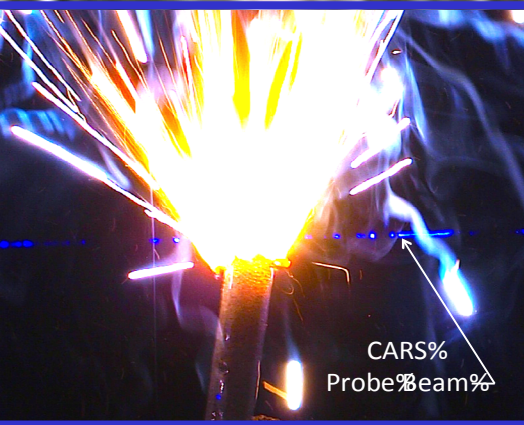

Sean P. Kearney and Daniel R. Guildenbecher  
*Engineering Sciences Center  
Sandia National Laboratories  
Albuquerque, NM 87185  
([spkearn@sandia.gov](mailto:spkearn@sandia.gov))*



Sandia  
National  
Laboratories

*Exceptional  
service  
in the  
national  
interest*



Sandia National Laboratories is a multi-program laboratory managed and operated by Sandia Corporation, a wholly owned subsidiary of Lockheed Martin Corporation, for the U.S. Department of Energy's National Nuclear Security Administration under contract DE-AC04-94AL85000.

- Background
  - Sandia applications in “hostile” environments
  - Nanosecond CARS detection in particle-laden flames
- Ultrafast (fs/ps) Rotational CARS
- Successful application to metallized propellant flame
  - Propellant burn experiment
  - Behavior of CARS spectra with probe delay
  - Temperature/oxygen statistics
- Conclusion and future work

- ***DOE strategic systems safety***
- ***DoD/WFO applications***
- ***Challenging environments***
- ***Large-scale***
- ***Heat, blast, particulate***



<http://www.cbsnews.com/news/rocket-crash-no-immediate-threat-to-station-but-cause-is-unknown/>

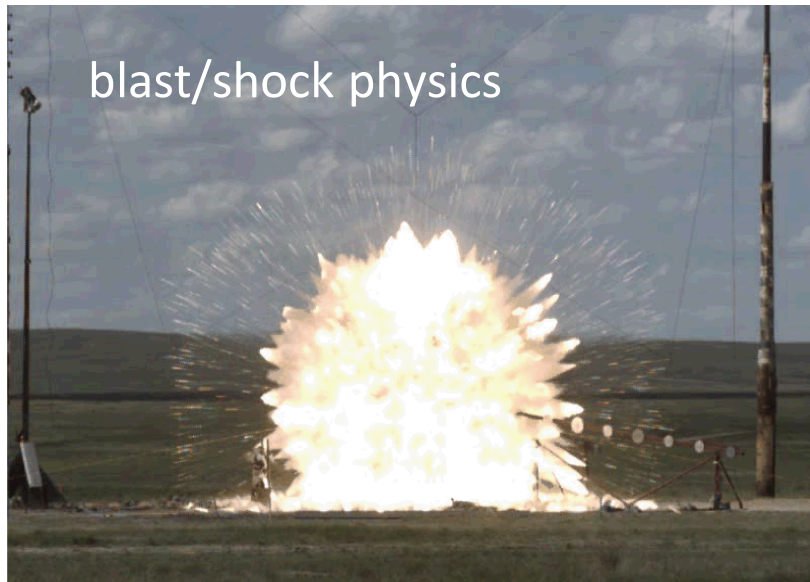

<http://abcnews.go.com/Technology/Travel/wireStory?id=3529012>

# Metallized Propellant Combustion

■ *Metal burn represents an extraordinarily hostile environment for laser diagnostics*

- *Very high temperatures –  $T > 3000$  K!*
- *High luminosity*
- *Scattering*

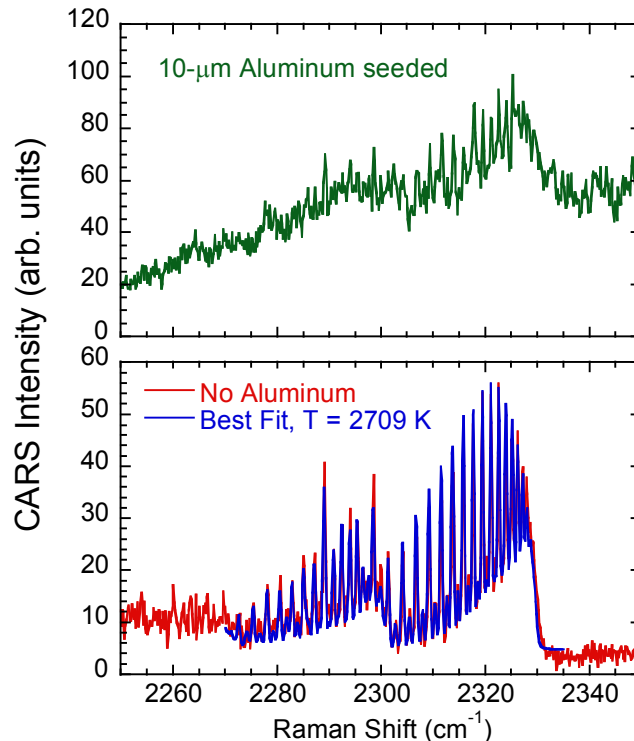

*ns-CARS spectra with and without Al particles*

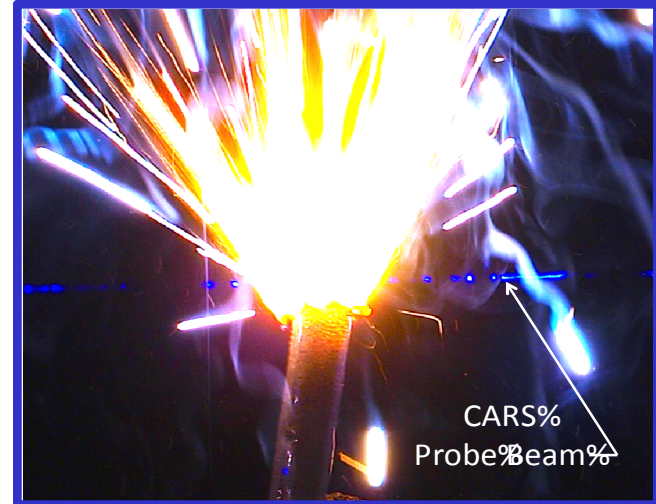

- *Previous gas-temperature measurements with ns CARS were unsuccessful*
  - *Metal-particle-induced breakdown/plasma formation*
  - *Disastrously high levels of nonresonant background*

Time-Domain Rotational Raman:  $\tau_{\text{laser}} \ll \tau_{\text{molecule}}$

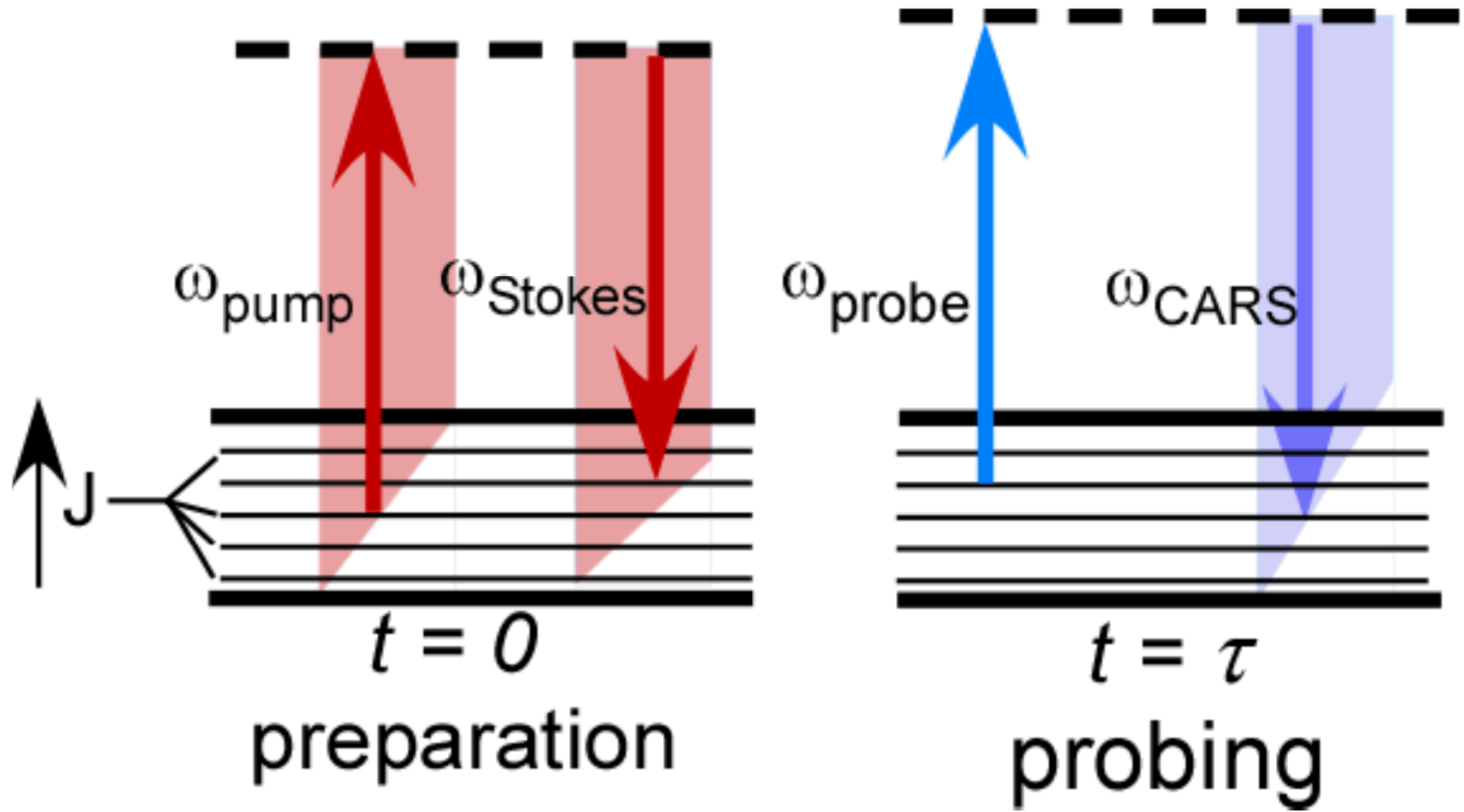

# fs/ps Rotational CARS processes

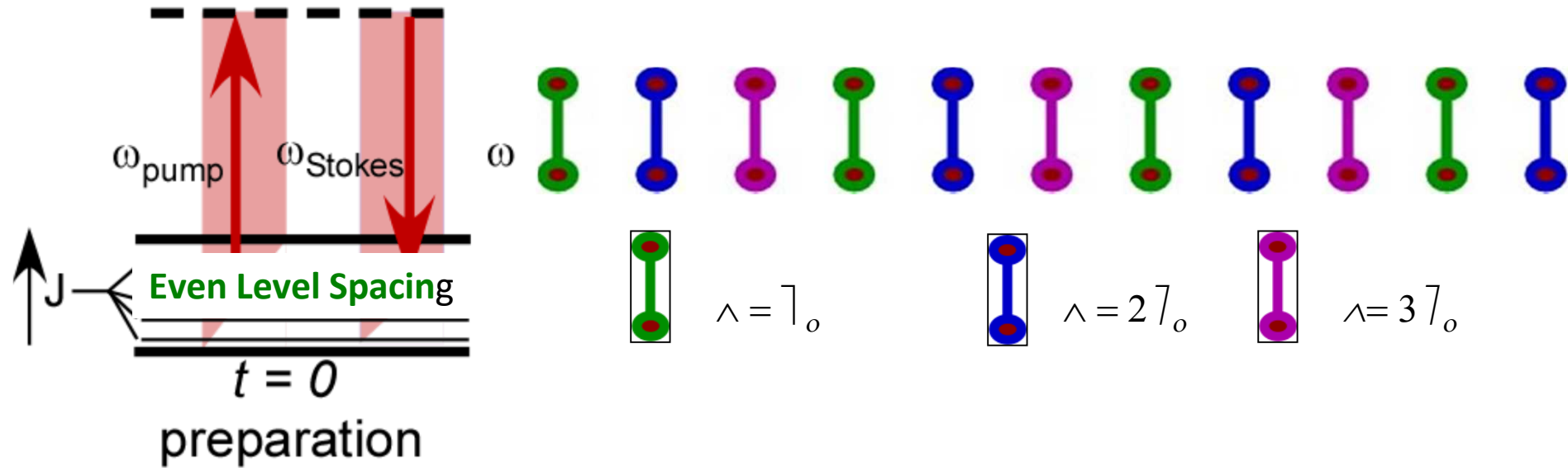

$$\chi = \sum_J W_J \exp(i\omega_J t) \exp(-\Gamma_J t)$$

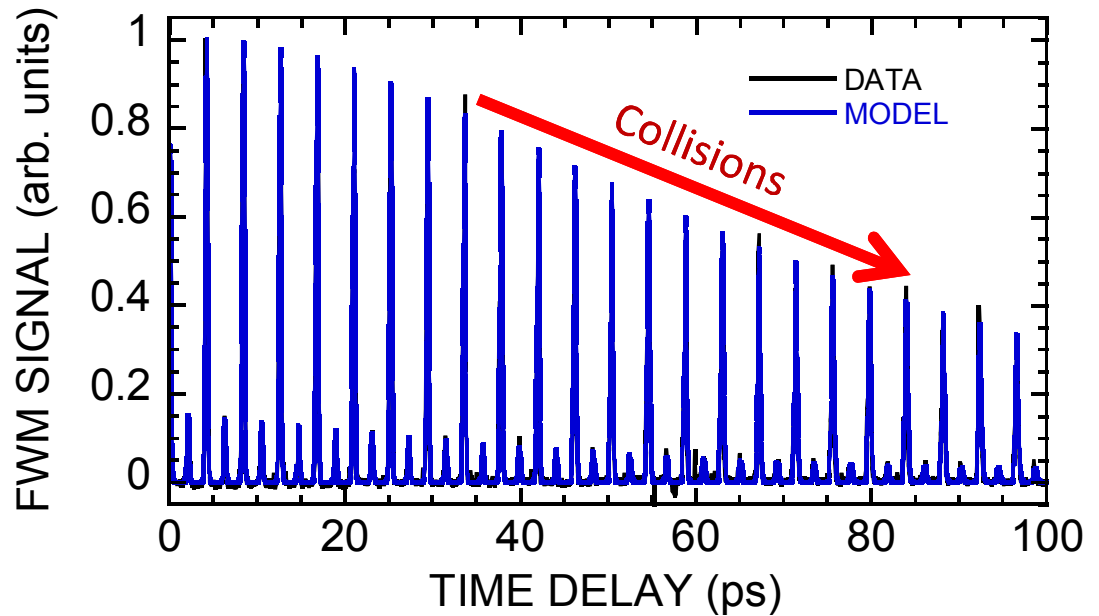

# fs/ps Rotational CARS processes

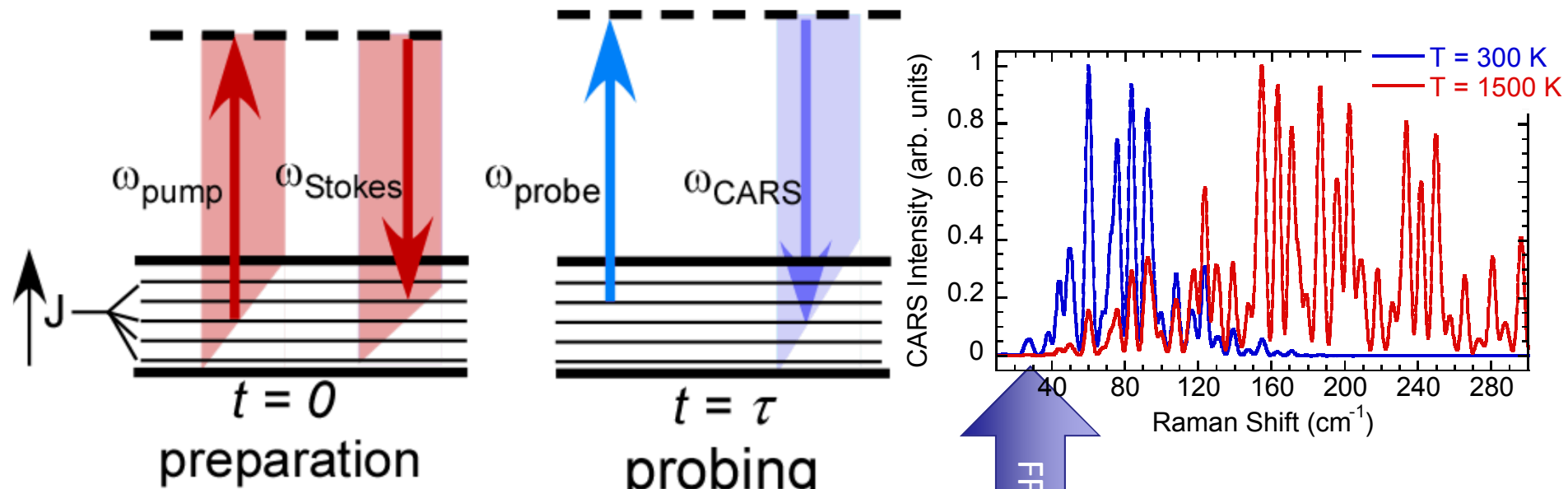

$$\chi = \sum_J W_J \exp(i\omega_J t) \exp(-\Gamma_J t)$$

$$E_{\text{CARS}}(t - \tau) = E_{\text{probe}}(t - \tau) \times \chi(t)$$

$$W_J = X \gamma^2 b_{JJ'} (N_{J'} - N_J)$$

$$\frac{N_J}{N} \sim \frac{1}{T} \exp(-\epsilon_J / kT)$$

probing

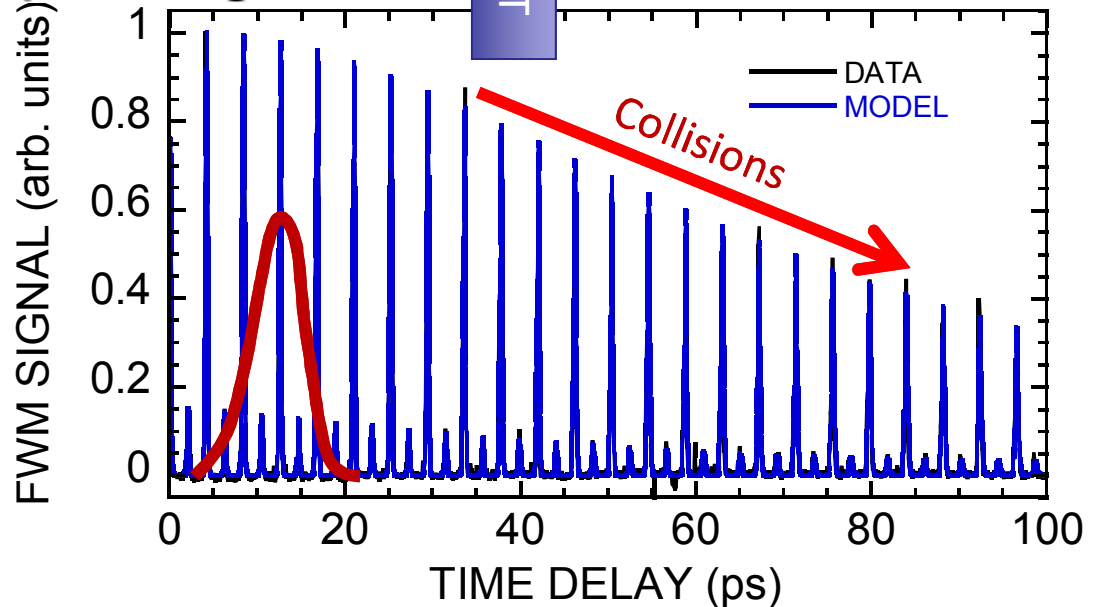

# fs/ps CARS instrument

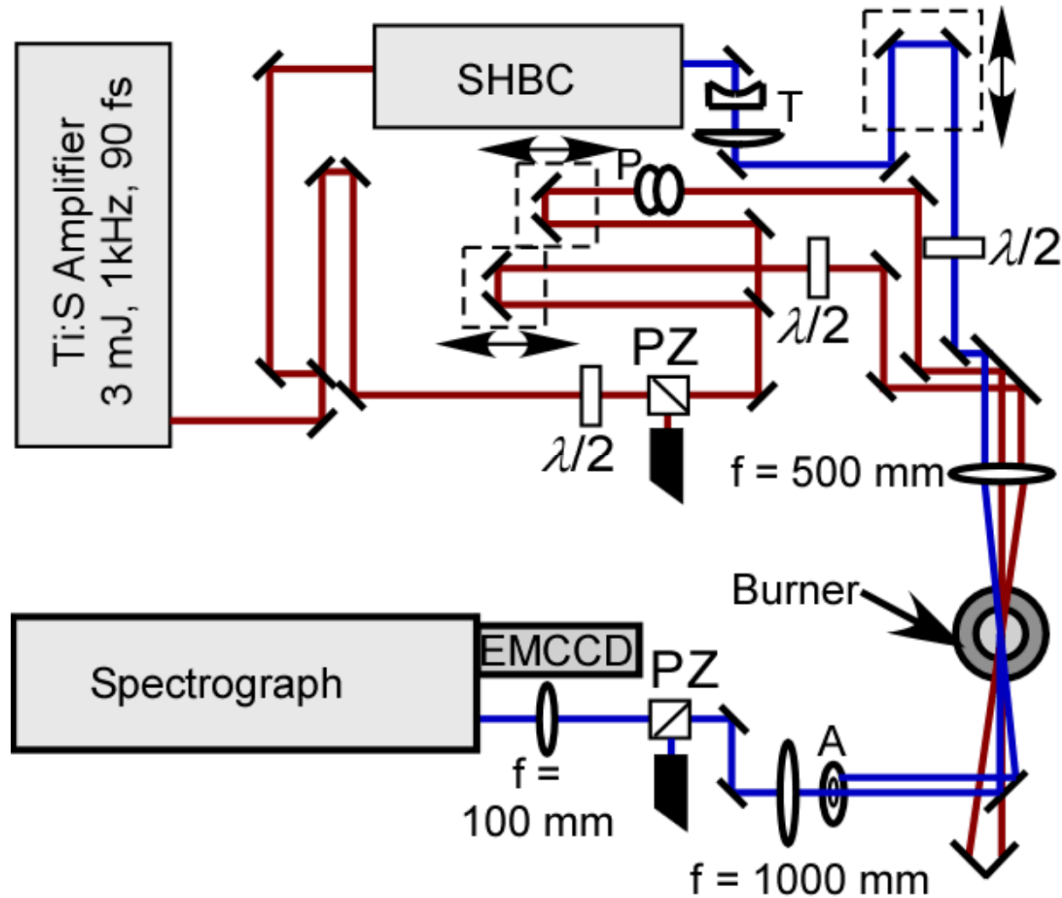

# Second-Harmonic Bandwidth Compression (SHBC)

- Commercial device (Light Conversion)
- Converts fs radiation at 800 nm to ps radiation at 400 nm
- Grating pulse stretchers
- **Phase-conjugate** temporal chirps imparted upon broadband fs pumps
- Sum-frequency generation in BBO

$$\Delta\omega_{sfg} \sim (\Delta t)^{-1}$$

- Conversion efficiency: 35-50%!
- Output pulse energy: 1-1.4 mJ!

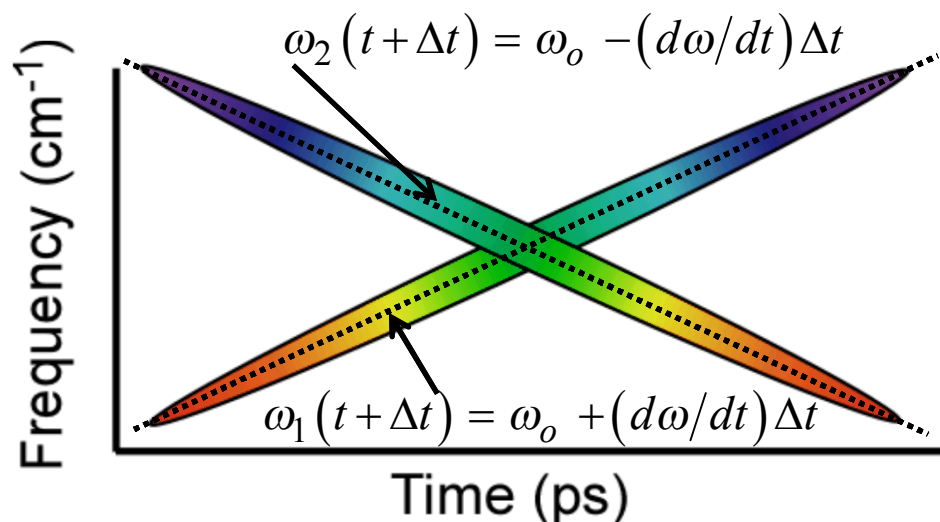
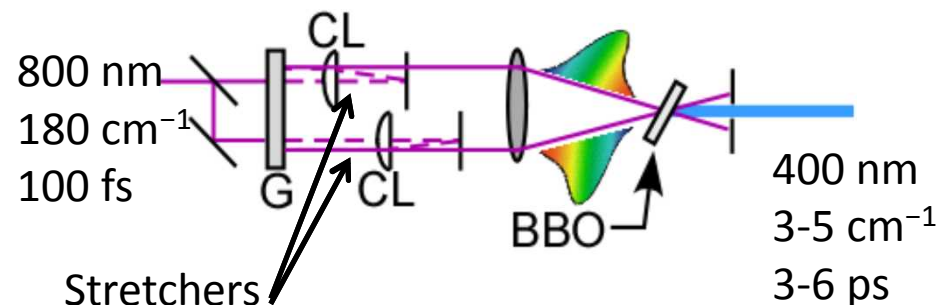

$$\omega_{sfg} = \omega_1 + \omega_2 = 2\omega_o$$

# AP Propellant Strand Burner Experiments

- *Aluminized ammonium-perchlorate (AP) propellant strands*
- *Hostile environment for diagnostics*
  - *Very high temperatures – over 3,000 K!*
  - *Large molten-metal particles 10-100  $\mu\text{m}$*
  - *Significant levels of smoke*
- *Particle size distribution measured by digital inline holography (Guildenbecher, Sandia)*

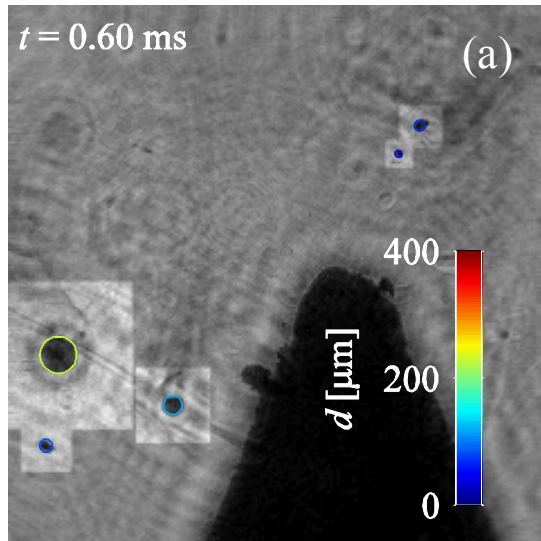

*Refocused DIH Hologram and Al Particle Size Distributions (Guildenbecher et al., Appl. Opt. 2016)*

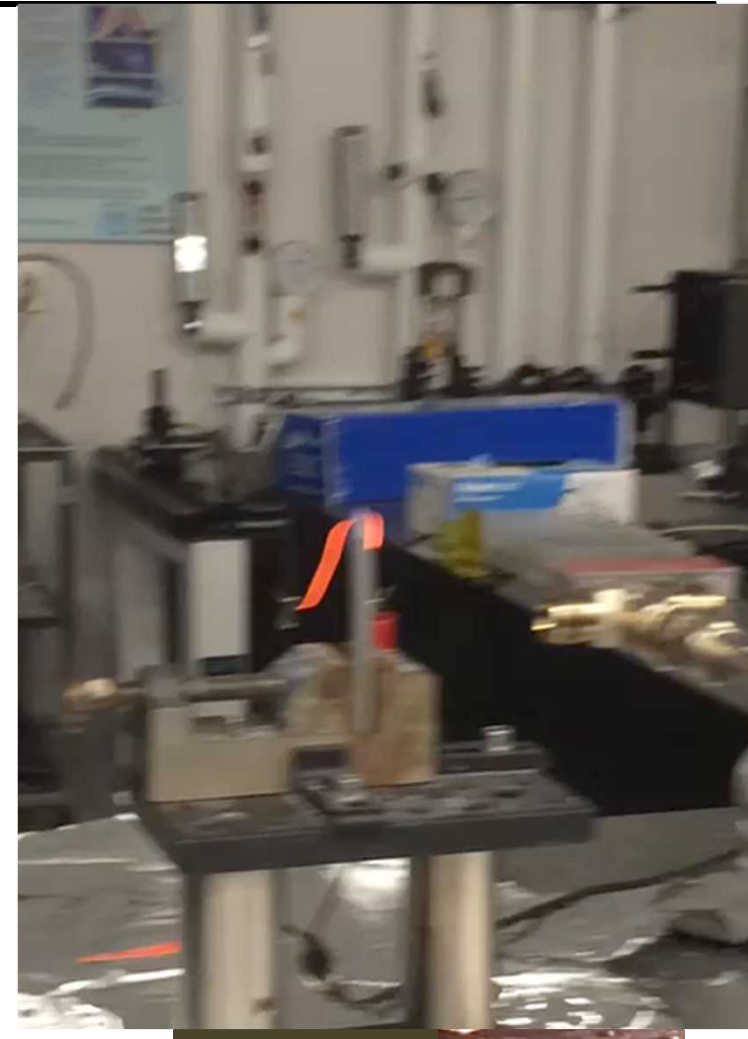

*Video Recorded During CARS Measurements*

# AP Propellant Strand Burner Experiments

- *Aluminized ammonium-perchlorate (AP) propellant strands*
- *Hostile environment for diagnostics*
  - *Very high temperatures – over 3,000 K!*
  - *Large molten-metal particles 10-100  $\mu\text{m}$*
  - *Significant levels of smoke*
- *Particle size distribution measured by digital inline holography (Guildenbecher, Sandia)*

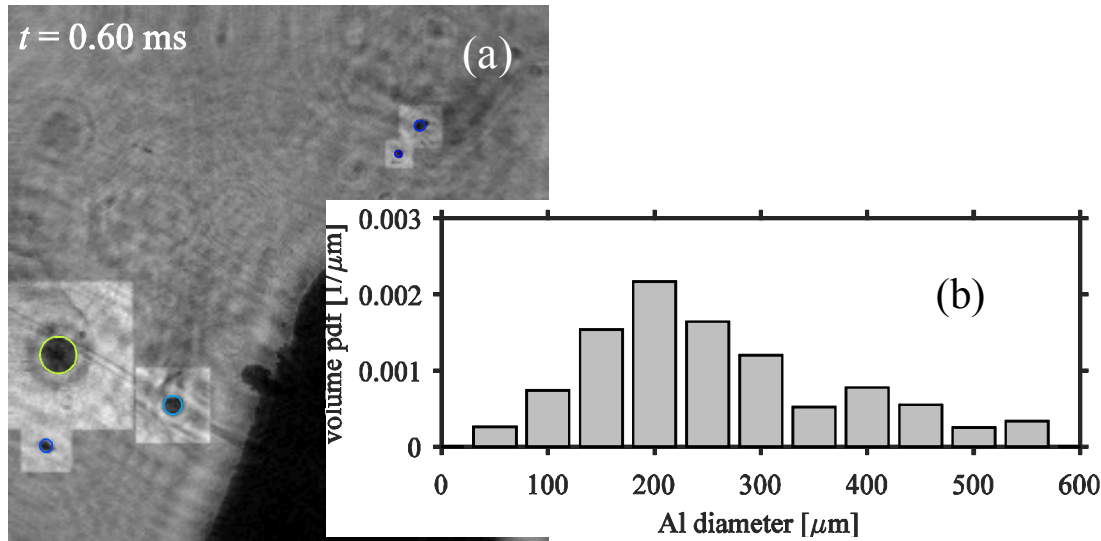

*Refocused DIH Hologram and Al Particle Size Distributions (Guildenbecher et al., Appl. Opt. 2016)*



*Video Recorded During CARS Measurements*

# Advantages of ultrafast CARS for metal-burn problems

- **Low total pulse energy**
  - $\sim 1$  mJ or less
  - Factor of  $\sim 40$ -100 lower than with ns laser pulses
  - Reduces the likelihood of breakdown-type interference
- **Time-gate elimination of nonresonant background**
  - Nonresonant signal arises from response of electrons to fs forcing
  - Fast decay (fs)
- **Raman-resonant signal results from much slower, nuclear response**

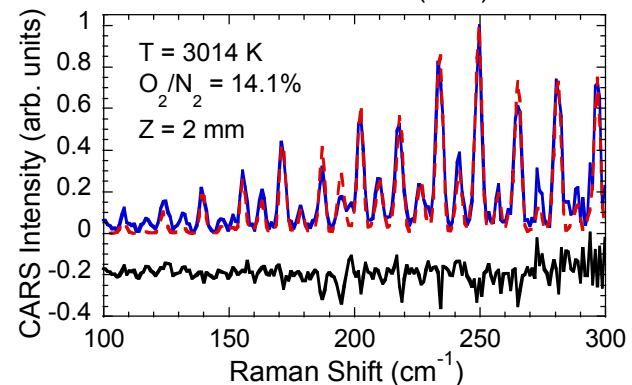
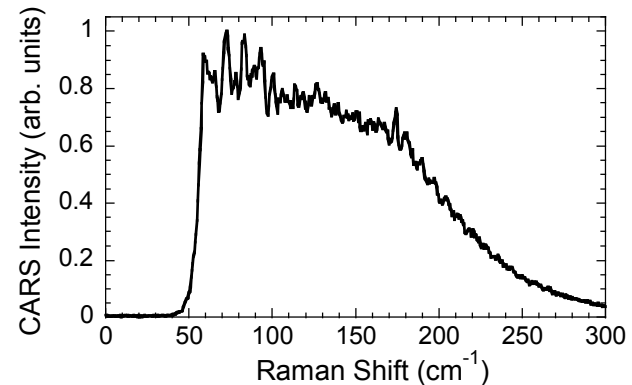
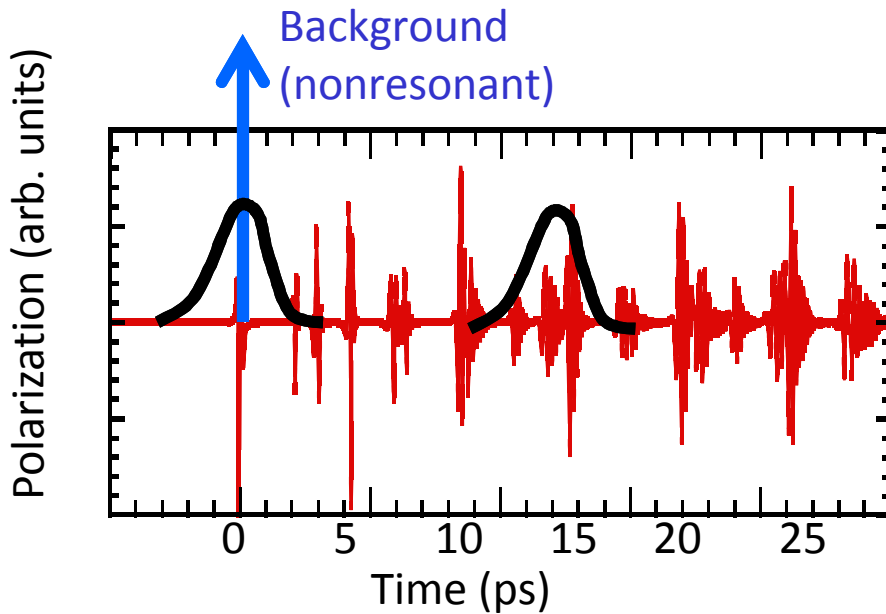

# Single-laser-shot spectra

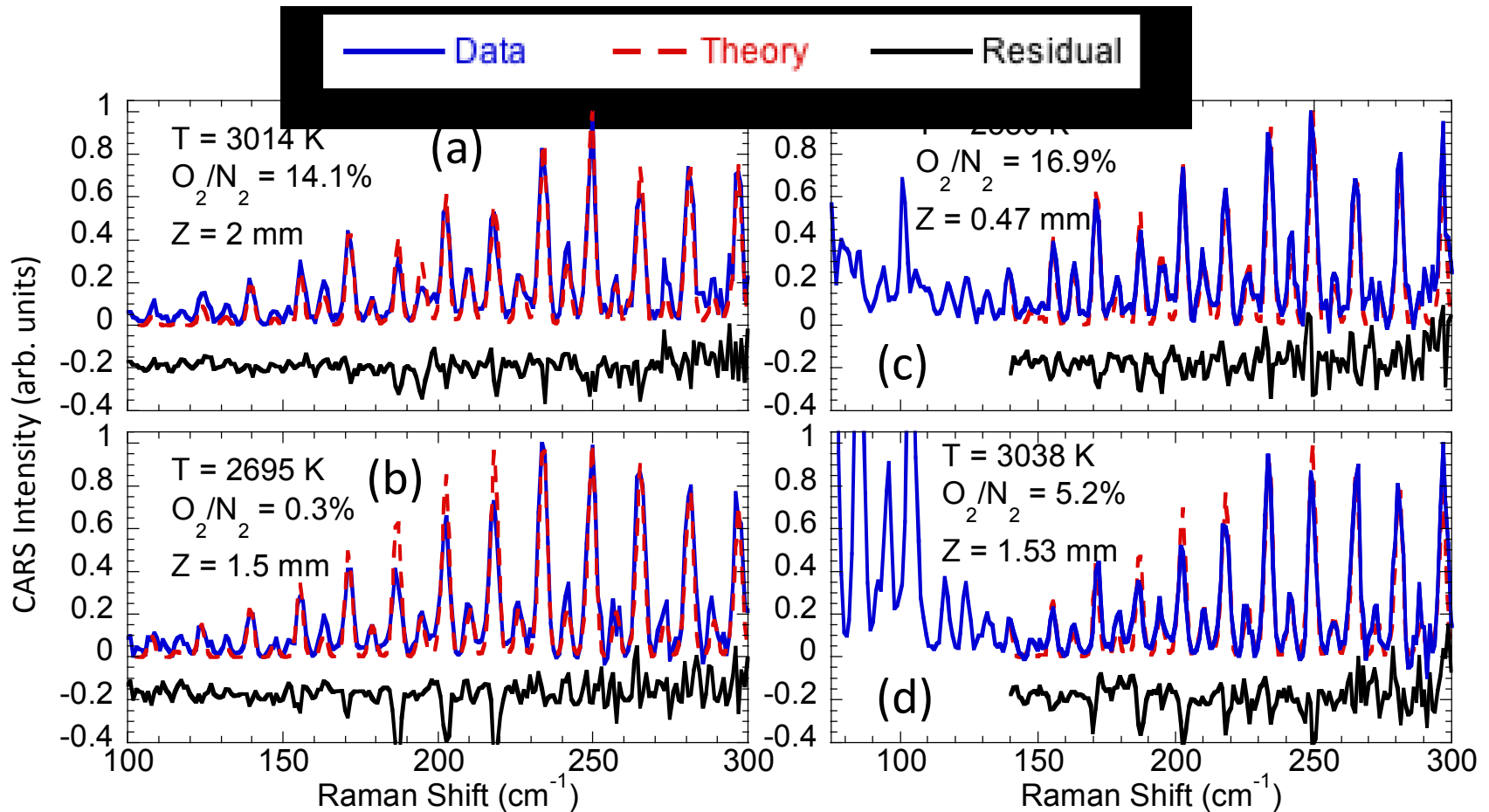

# CARS Results from Propellant Burns

- **Results for CARS measurements within 3 mm of propellant surface shown**
- **Height estimated from 1-kHz acquisition rate and burn rate of 800  $\mu\text{m}/\text{sec}$**
- **Spectra dominated by  $\text{N}_2$  and  $\text{O}_2$  contributions**
- **$\text{Cl}_2$ ;  $\text{HCl}$ ;  $\text{NO}$ ;  $\text{NO}_2$  also present**
- **Switch to vibrational CARS for follow-on experiments**
- **Decrease measurement volume length**

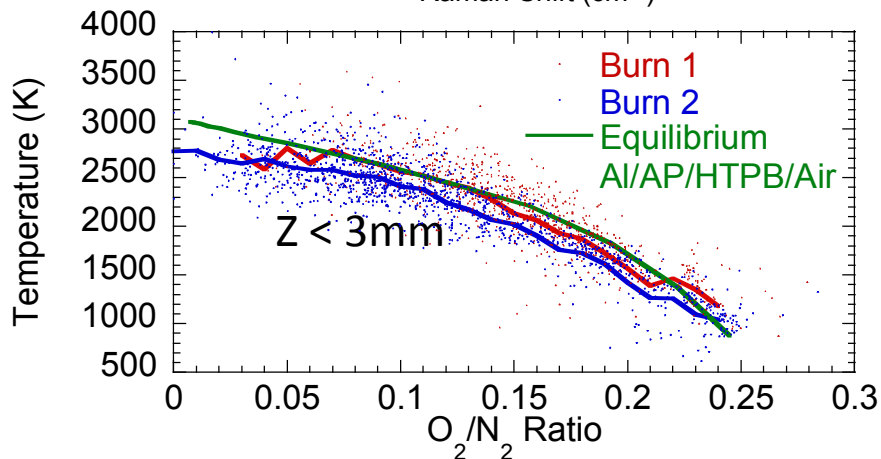
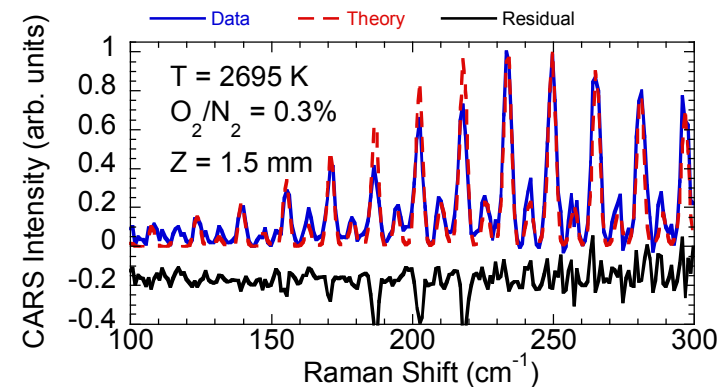
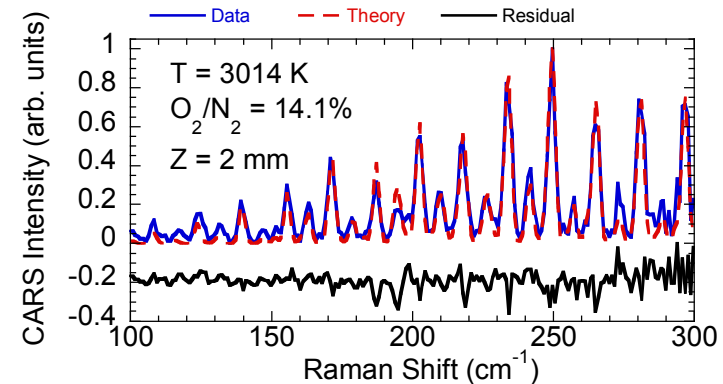
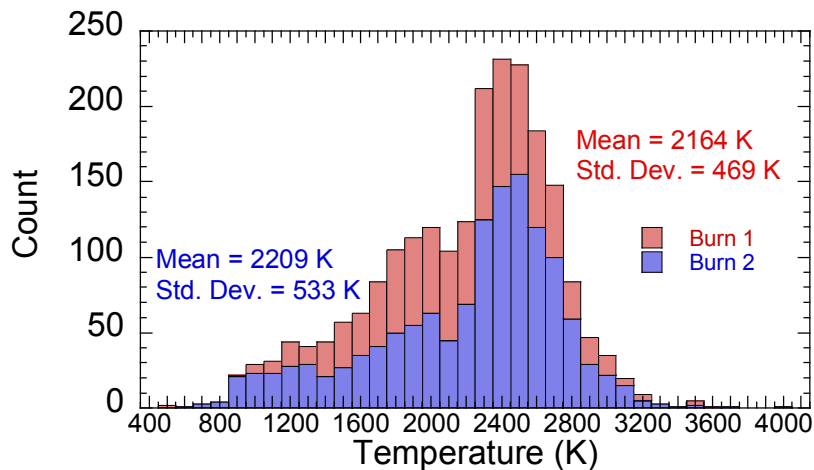

# Conclusion and Path Forward

- We have successfully applied fs/ps rotational CARS in an aluminized AP propellant flame at lab scale
- Large-scale, 10-100  $\mu\text{m}$  aluminum and temperatures as high as 3,000 K make this a challenging measurement environment
- Time delayed probing results in elimination of intense nonresonant background, presumably arising from particle-enhanced breakdown
- No loss of Raman-resonant signal!
- Temperature/O<sub>2</sub> statistics within 3-10% of adiabatic equilibrium

## *What's next?*

- Switch to vibrational CARS for improved high-temperature sensitivity
- Higher signal levels
- Improved axial spatial resolution
- 1-D line imaging

# AP Propellant Strand Burner Experiments

- **Aluminized ammonium-perchlorate (AP) propellant strands**
- **Hostile environment for diagnostics**
  - **Very high temperatures – fluctuations over 3,000 K!**
  - **Dense field of large molten-metal particles 10-100  $\mu\text{m}$**
- **Particle size distribution measured by digital inline holography (Guildenbecher, Sandia)**

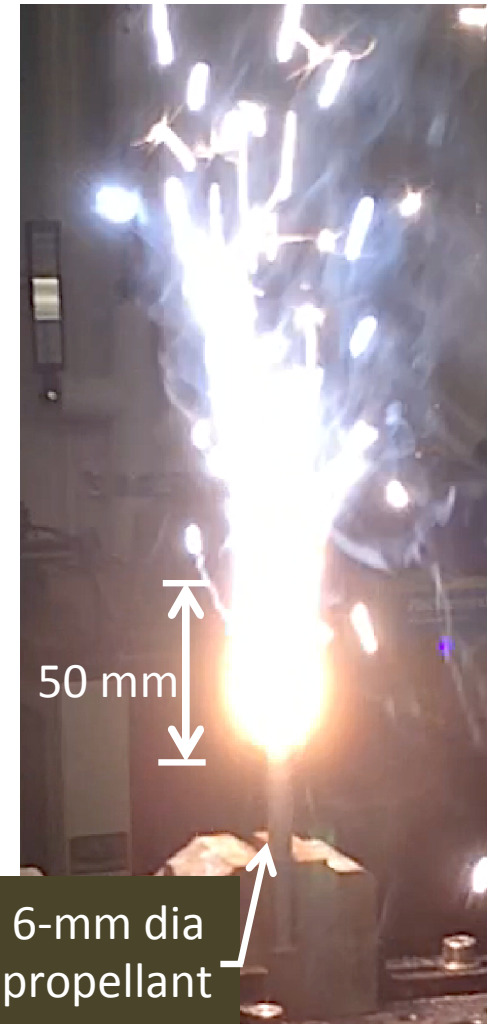
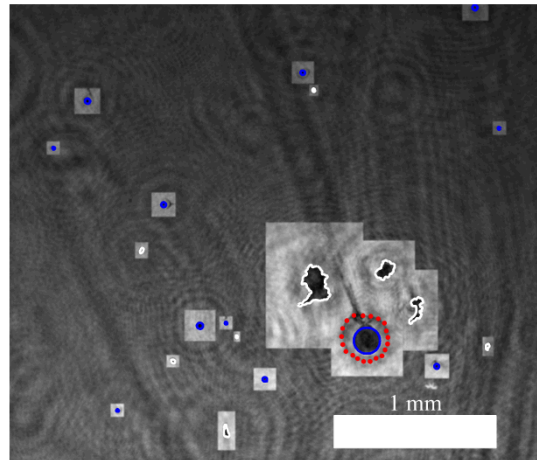
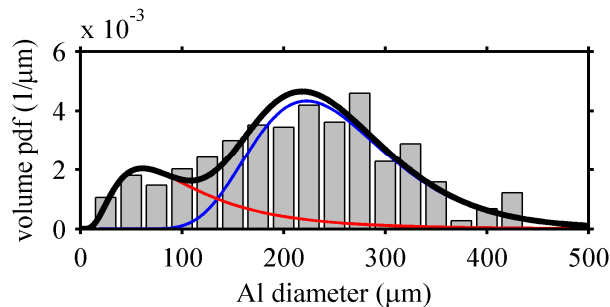
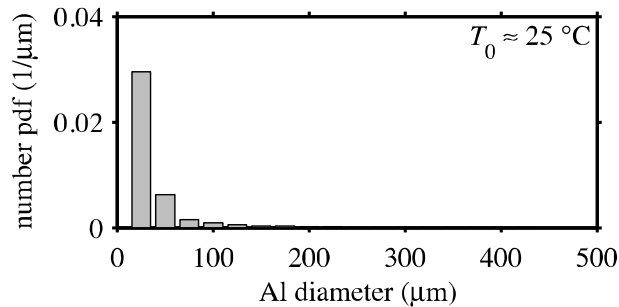

[Refocused DIH Hologram and Al Particle Size Distributions \(Guildenbecher et al., Appl. Opt. 2016\)](#)

[Video Recorded During CARS Measurements](#)