

Exceptional service in the national interest



Micro-Sandwich Test of Vapor-Deposited Hexanitroazobenzene (HNAB)

Caitlin O'Grady



Sandia National Laboratories is a multi-program laboratory managed and operated by Sandia Corporation, a wholly owned subsidiary of Lockheed Martin Corporation, for the U.S. Department of Energy's National Nuclear Security Administration under contract DE-AC04-94AL85000. SAND2015-4664C.

Acknowledgements

I would like to gratefully acknowledge:

- Alexander S. Tappan and Robert A. Knepper for assistance with this project
- Michael P. Marquez for his assistance with deposition and assembly
- J. Patrick Ball, Thomas Conwell, and Jon Vasiliauskas for their assistance with detonation testing
- Chuck Walker and Adrian Casias for assistance with annealing and cutting of tantalum
- Juan Carlos Rodriguez for assistance with design and modeling
- Ben Hanks for assistance with manufacturing
- Billy Cunningham and Amanda Gomez for assistance with deposition masks
- I would also like to thank my UNM advisor Dr. Truman for all of his help during this process and my final committee member Dr. Asal Naseri for agreeing to be on my committee

This project was funded by Sandia National Laboratories' Laboratory Directed Research and Development Program.

- Introduction
 - Project Overview
 - Sandwich Test
 - Physical Vapor Deposition
 - Liner Material
 - HNAB
- Experimental
 - Adhesion Layers
 - Diagnostic Equipment
 - Sandwich Assembly
- Results
- Conclusion

- **Introduction**
 - **Project Overview**
 - **Sandwich Test**
 - **Physical Vapor Deposition**
 - **Liner Material**
 - **HNAB**
- **Experimental**
 - Adhesion Layers
 - Diagnostic Equipment
 - Sandwich Assembly
- **Results**
- **Conclusion**

- This project:
 - Develop an experiment and acquire data that support developing the products equation of state (EOS) for HNAB
 - A series of small-scale sandwich tests were performed on vapor-deposited HNAB
 - Sandwich test provided velocity of the metal liner during explosive loading
 - Experimental data will be provided to computational modelers who will develop the EOS and compare to existing computational models EOS

Jones-Wilkins-Lee Equation of State

- Function used to model the pressure of expanded detonation product gases
 - Not a fundamental EOS
 - Yields an incomplete description of the products' states
- Provides pressure as a function of specific volume
- Empirical form
 - $P = Ae^{-R_1V} + Be^{-R_2V} + CV^{-(1+\omega)}$
 - Where A, B, C, R_1 , R_2 , and ω are all constants that are specific to the explosive. P refers to the pressure and V refers to the specific volume.

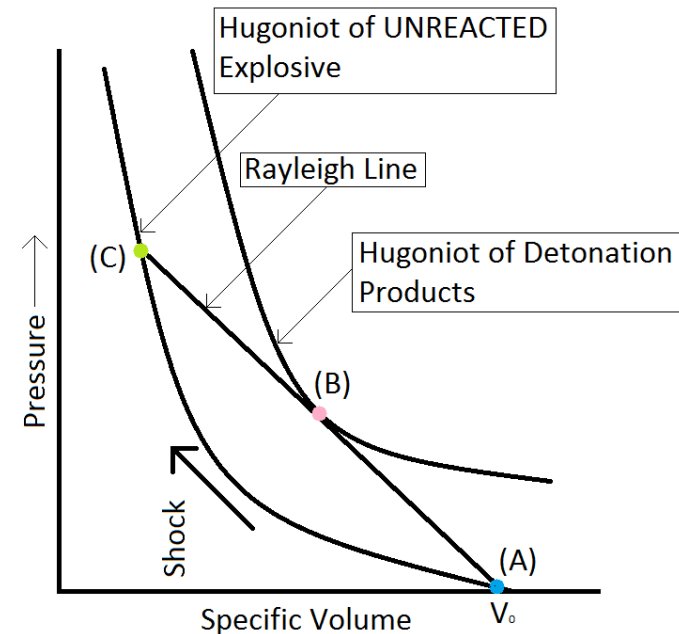

P-V representation of detonation with (A) as the initial state of unreacted explosive, (B) as the state of reaction products, and (C) as the jump condition to the fully shocked but unreacted explosive. Adapted from Cooper (1996).

What is a Sandwich Test?

- Similar to a cylinder expansion test
 - Slab geometry vs. cylindrical geometry
- Explosive confined on 2 sides that is detonated at one end
- Can be used to determine data that will lead to development of products EOS

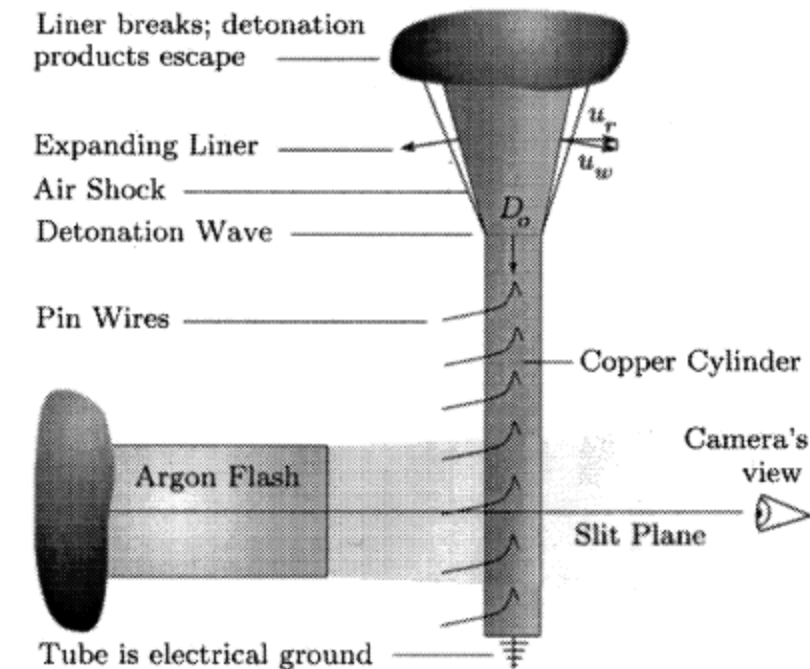

(Left) Schematic diagram of a typical cylinder test (Davis and Hill 2002).

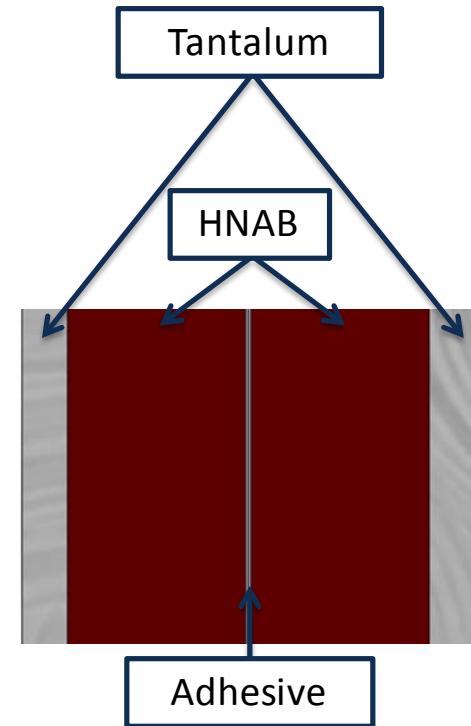

(Right) Cross-section of the micro-sandwich test.

Why Sandwich Test?

- Though it is similar to the cylinder expansion test, the sandwich test has a few advantages over the cylinder test
 - Thinner liners
 - Smaller geometry
 - Larger range of temperatures
- Sandwich test is better for vapor-deposited explosives, like HNAB

- Tantalum was chosen as liner material as it:
 - is stiff and ductile,
 - high density,
 - and is relatively easy to procure and cut into the 10 mm × 30 mm substrate
- Three different liner thicknesses
 - $50.8 \pm 2.5 \mu\text{m}$ (2 mil)
 - $76.2 \pm 5.1 \mu\text{m}$ (3 mil)
 - $101.6 \pm 1.3 \mu\text{m}$ (4 mil)
- Tantalum was annealed before deposition



(Above) Image of a tantalum substrate with 10 mm × 30 mm dimensions.

Physical Vapor Deposition (PVD)

- PVD by vacuum thermal evaporation is used with hexanitroazobenzene (HNAB)
- Conducted in a custom deposition chamber located at Sandia National Laboratories
 - allows direct contact between the explosive and the substrate
 - control over the explosive geometry and microstructure
- Fast deposition rate ($\sim 200 \mu\text{m/hr}$) for HNAB



Custom deposition chamber used to deposit HNAB onto tantalum for this experiment, it is located at Sandia National Laboratories (Knepper, 2014).

(Below) Schematic of the deposition system used to deposit HNAB onto substrates (Knepper, 2014).

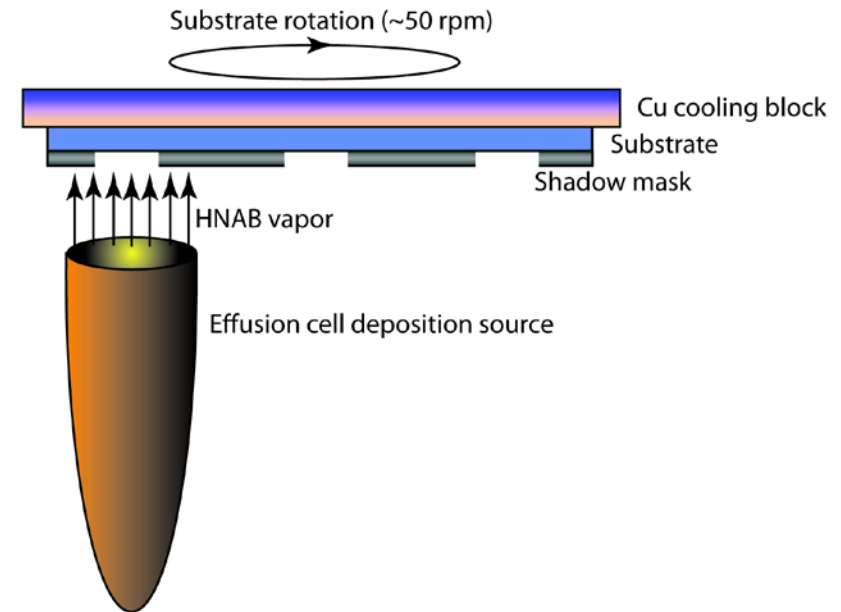

- High-vacuum deposition system
 - base pressure $\sim 10^{-4}$ Pa
- Nominal source-to-substrate distance of 10 mm from an effusion cell thermal deposition source
- Shadow masks used to define deposition geometry

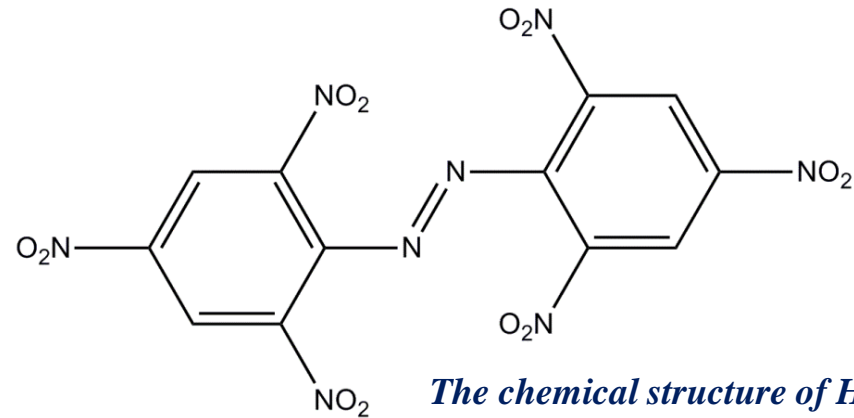

- HNAB films will crystallize from amorphous structure over time to a structure

- with very low porosity
- with a sub-micron grain size,
- with a smooth surface (~ 50 nm roughness).
- that is reproducible and
- that can detonate at very small thicknesses (less than 100 μm)
 - with a very consistent detonation velocity

- HNAB:

- MP = 221°C
- Chemically stable at melt to ~ 300°C
- $\rho \sim 1.744 \text{ g/cm}^3$ and ~99.5% dense after crystallization
- The films will crystallize into a mixture of two different polymorphs
 - the orange HNAB-II structure
 - a yellowish structure - yet to be identified

- Introduction
 - Project Overview
 - Sandwich Test
 - Physical Vapor Deposition
 - Liner Material
 - HNAB
- **Experimental**
 - **Adhesion Layers**
 - **Diagnostic Equipment**
 - **Sandwich Assembly**
- Results
- Conclusion

HNAB Crystallization

- Two phases result
 - HNAB-II
 - Orange/red color
 - Known detonation properties
 - Yet-to-be-determined unknown phase
 - Yellow color
 - Different detonation properties
- the two crystal structures have significantly different detonation properties
- the unknown structure will not detonate at thicknesses where HNAB-II readily supports detonation

(Right) Plan-views of two images of HNAB films on tantalum substrates before crystallization (a) and after crystallization at 35 °C (b) using plasma etching cleaning methods.

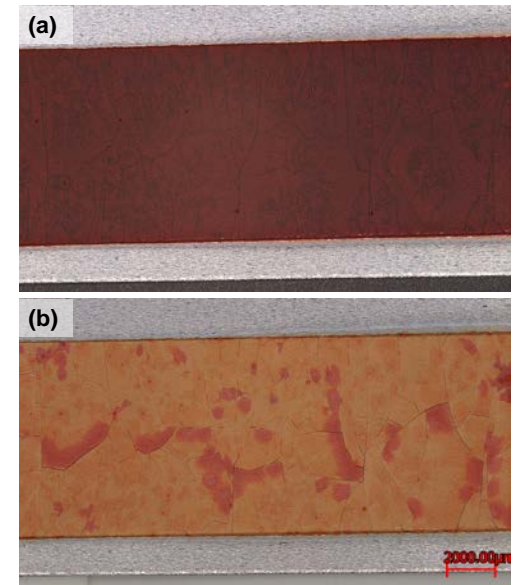

(Above) Plan-View of regular cleaned tantalum substrate with HNAB crystallized at 35 °C

Substrate Cleaning Methods

- (a) Solvent Cleaned
 - ethanol wipe
 - acetone wipe
- (b) Plasma Etched
 - solvent cleaned (ethanol and acetone wipes)
 - plasma etched tantalum surface before deposition
- Neither method yielded desirable results
 - cracking
 - unknown yellow phase

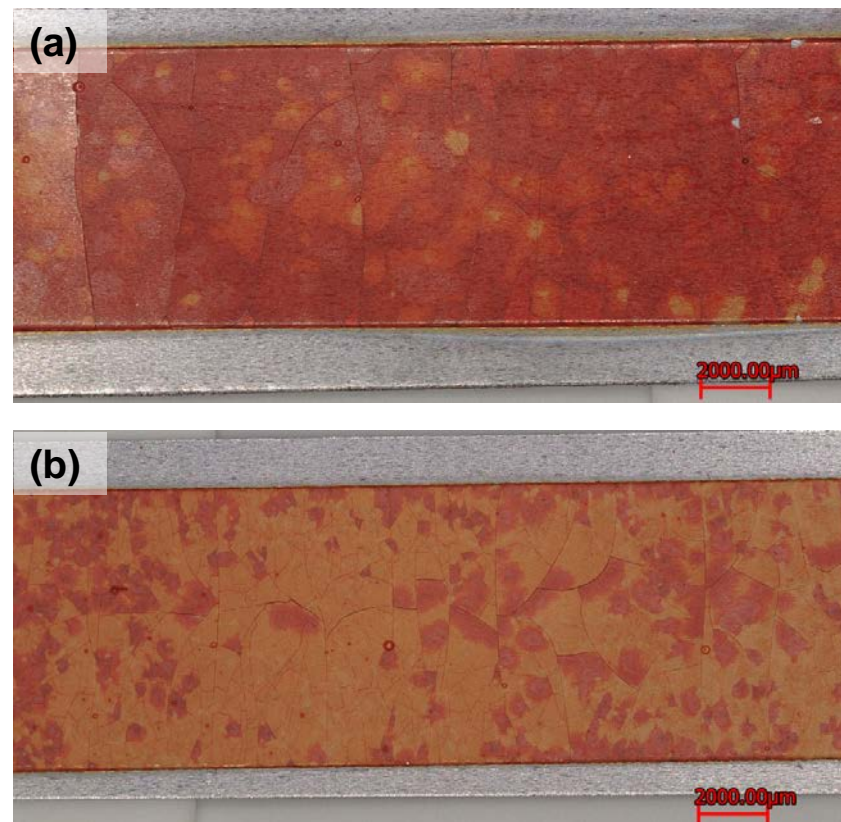

(Above) Plan-view images of two of HNAB films on tantalum substrates after crystallization at 35 °C using (a) solvent cleaning method and (b) plasma etching cleaning methods. Color difference due to unknown phase of HNAB (yellow) and HNAB-II (red/orange).

Adhesion Layer Needed

Parylene – what is it?

- Conformal protective polymer coating material utilized to uniformly protect any component configuration on such diverse substrates as:
 - metal, glass, paper, resin, plastic, ceramic, ferrite and silicon
 - Parylene conforms to virtually any shape, including sharp edges, crevices, points; or flat and exposed internal surfaces.
- 3 Different Dimers
 - Parylene N,
 - Parylene C, and
 - Parylene D

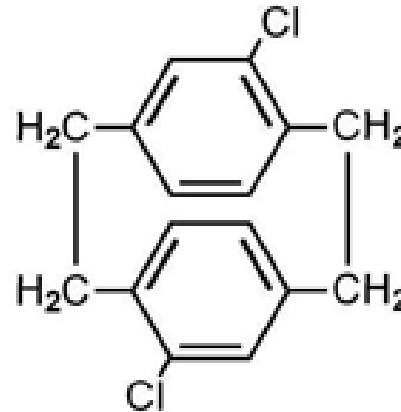

Parylene C dimer. Parylene C coating investigated as adhesion layer for HNAB.

Parylene Coating Process

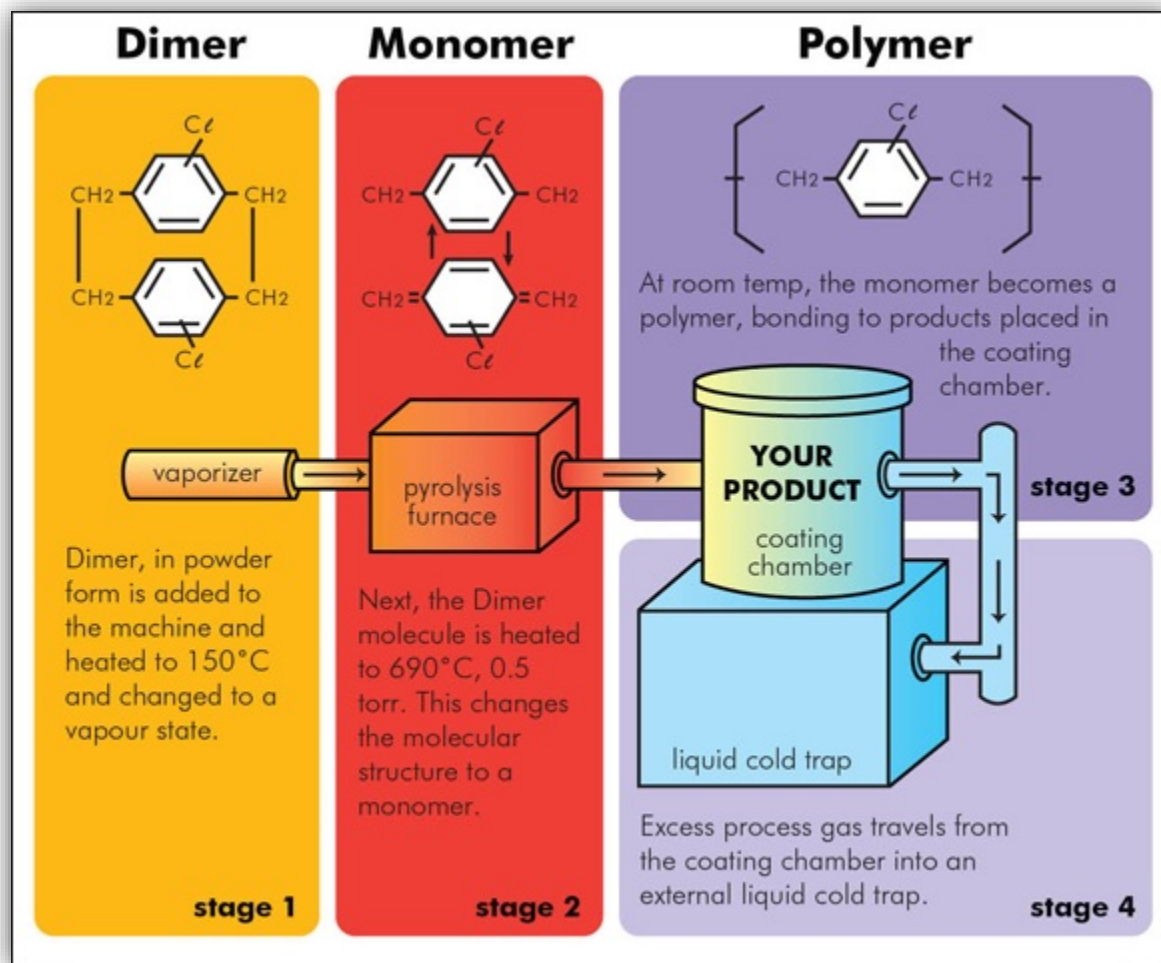

Prior to working with explosives, the temperature in the chamber during a deposition was experimentally measured (internal thermocouple) to be between 24 – 33°C.

Adhesion Experiment

Image	Base Layer	Adhesion Layer	Explosive Deposition	Capping Layer
a	Tantalum	Chromium	HNAB amorphous	
b	Tantalum	Chromium	HNAB amorphous	Parylene C
c	Tantalum	Parylene C	HNAB amorphous	
d	Tantalum		HNAB amorphous	Parylene C
e	Tantalum	Parylene C	HNAB amorphous	Parylene C

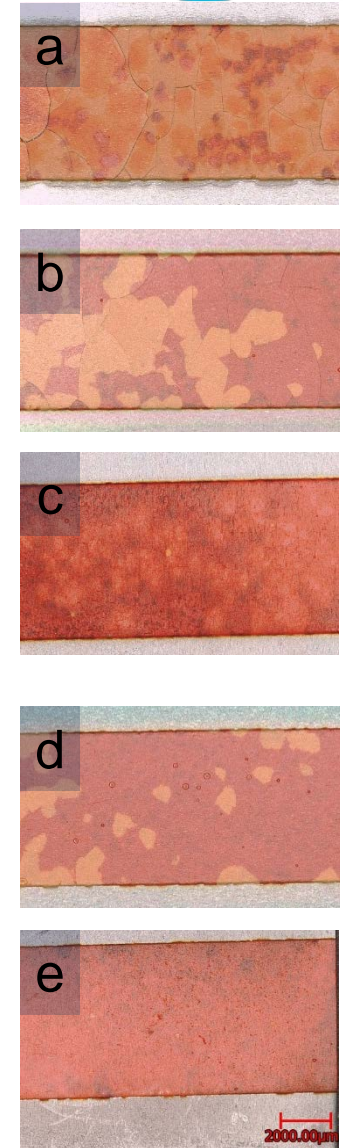
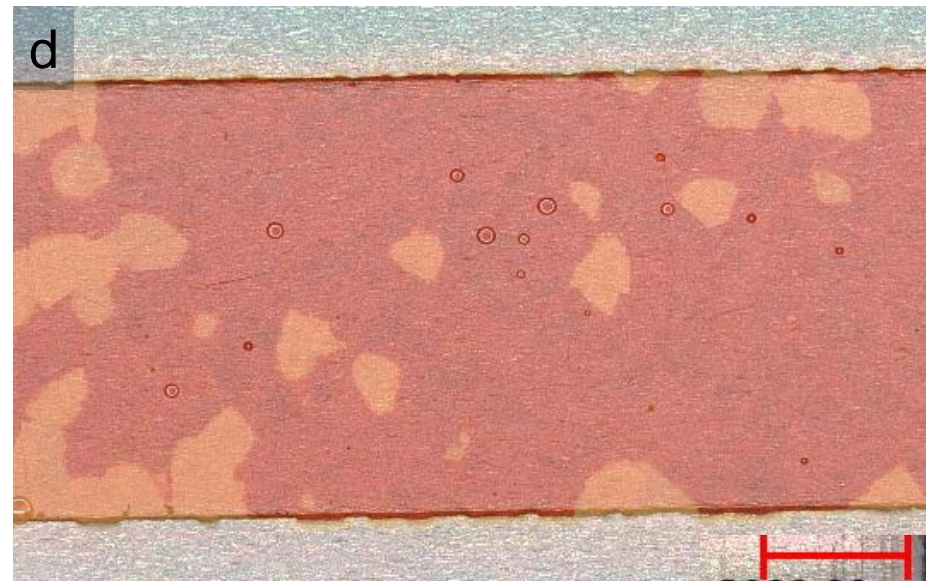

Table describes adhesion layers and correlates them to plan-view images of HNAB crystallized at 35 °C (all images are to the same scale).

- Deposition of HNAB (~100 µm) directly onto tantalum proved ineffective
- Other materials were explored as adhesion promoters, including
 - chromium (~50 nm) and
 - Parylene C (~1 – 2 µm)
 - All of the films were crystallized in an oven at 35°C



2000.00um



Micro-Sandwich Fixture

- Thickness of HNAB uniform between $105 \pm 2 \mu\text{m}$

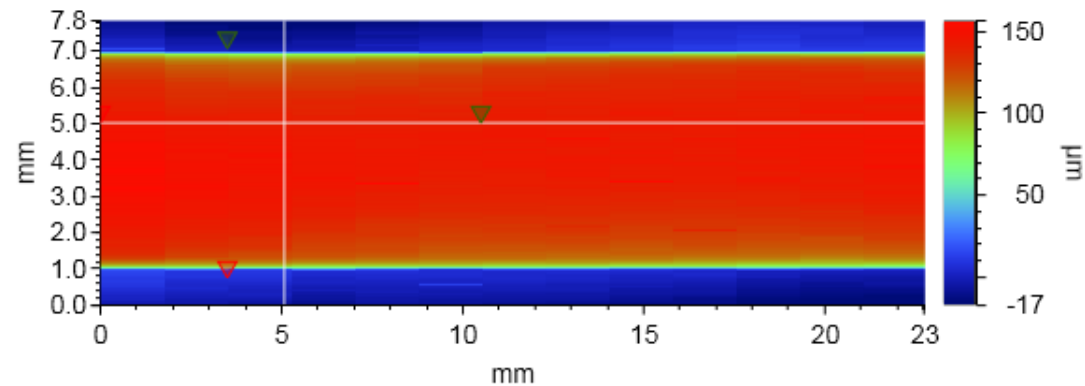

Plan-view map scan using Bruker DektakXT surface profiler system of 76.2 μm sample with crystallized HNAB deposited onto the surface and is capped by Parylene C.

Micro-Sandwich Fixture

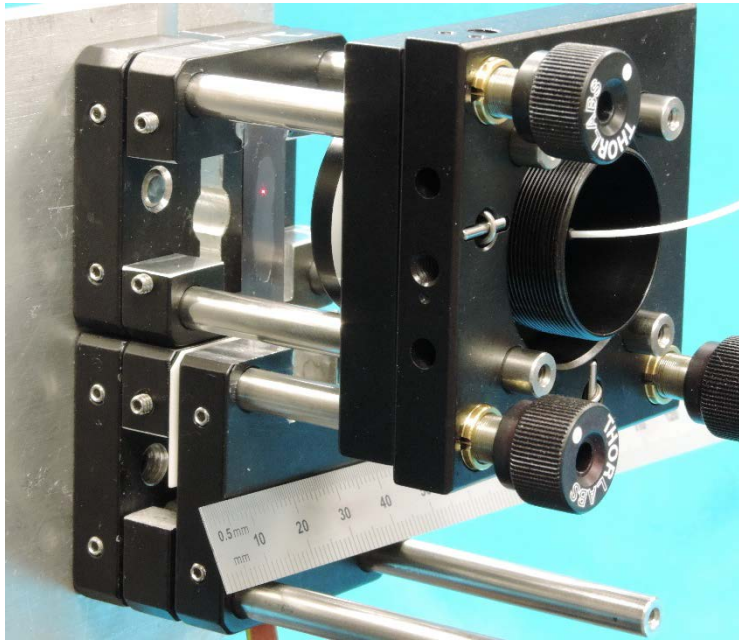

(Above) Image of the micro-sandwich assembly fixture with the PDV probe using a red alignment laser to show where the PDV probe laser will be located during the experiment.

- Thickness of HNAB uniform between $105 \pm 2 \mu\text{m}$

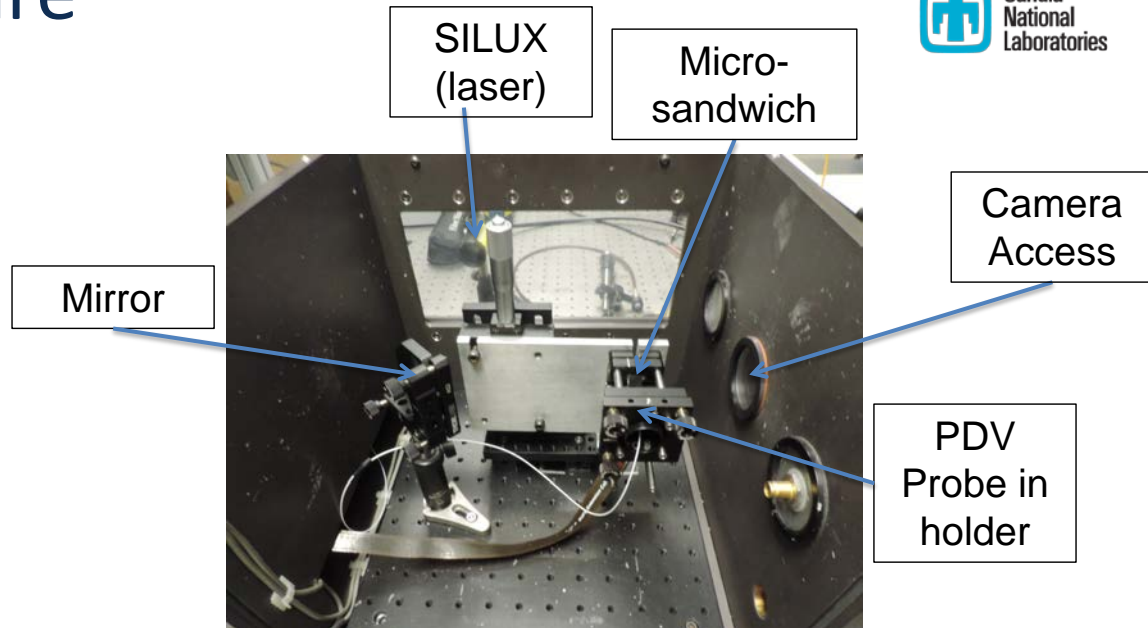

(Above) Image of the experimental setup inside the explosive chamber

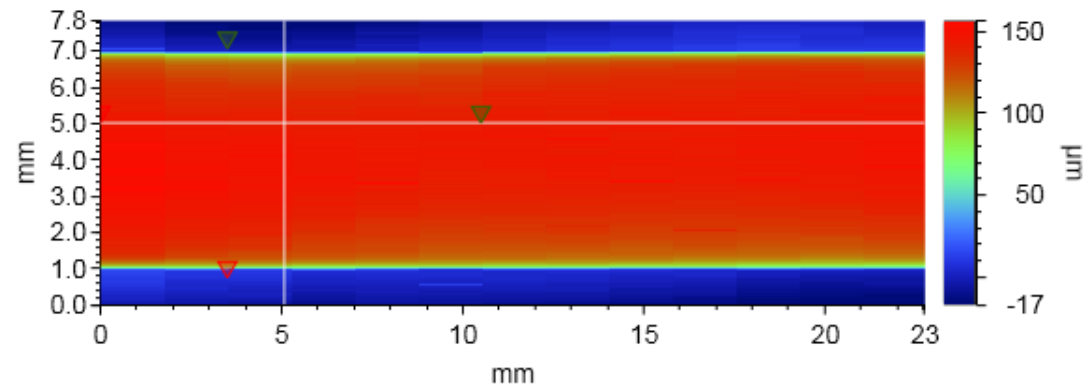

Plan-view map scan using Bruker DektakXT surface profiler system of $76.2 \mu\text{m}$ sample with crystallized HNAB deposited onto the surface and is capped by Parylene C.

Sandwich Assembly/Fixture

- Bottom sandwich substrate is placed with the HNAB face-up into the cutout of the cage plate
 - 1 mm spacer placed on top of it.
- Sylgard® 527 adhesive is added along the length of the explosive.
- Other half of the sandwich is placed with the explosive face-down on top of the adhesive covered substrate
 - not covering the 1 mm spacer.
- Once the adhesive cures, the sandwich is epoxied into place with 5-minute epoxy

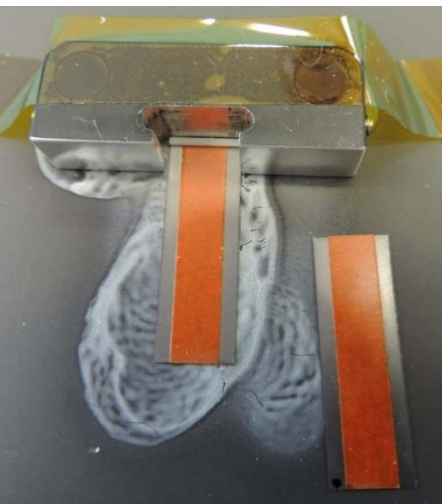

(Left) Image of pre-assembled sandwich with mold release agent to prevent adhesion to the flat surface where assembly took place.

(Right) Photograph of the micro-sandwich assembly inside the fixture

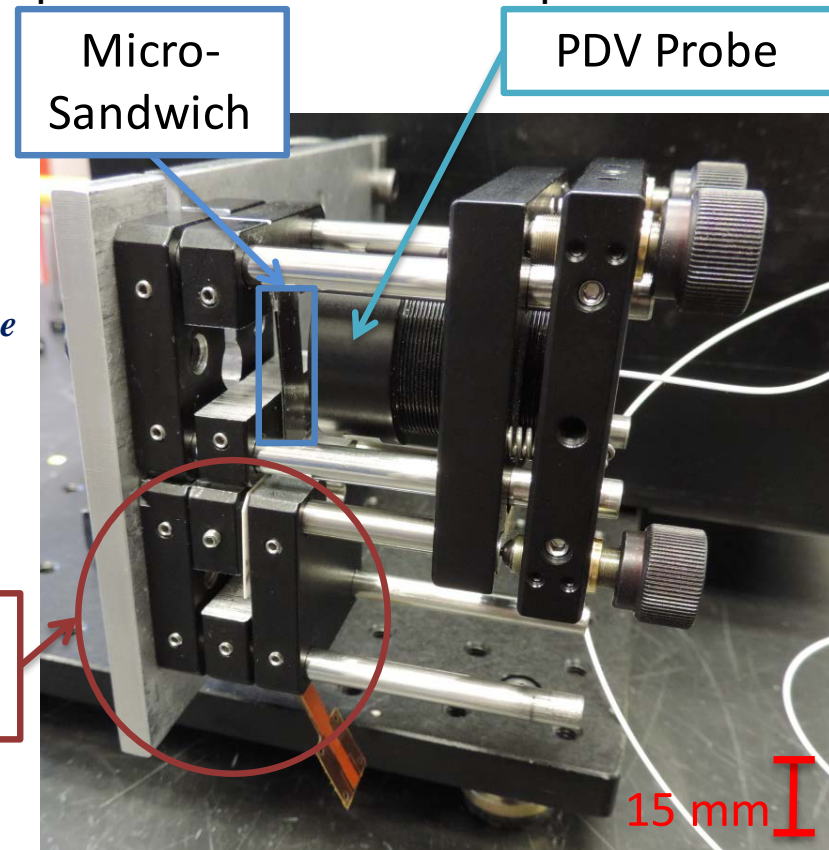

Micro-Sandwich

PDV Probe

Initiation Structure

15 mm

Diagnostics

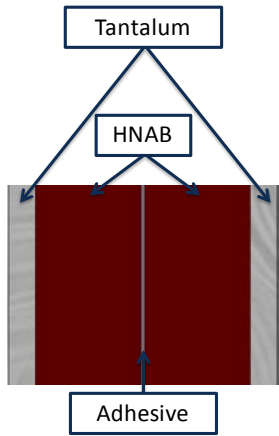

Micro-sandwich

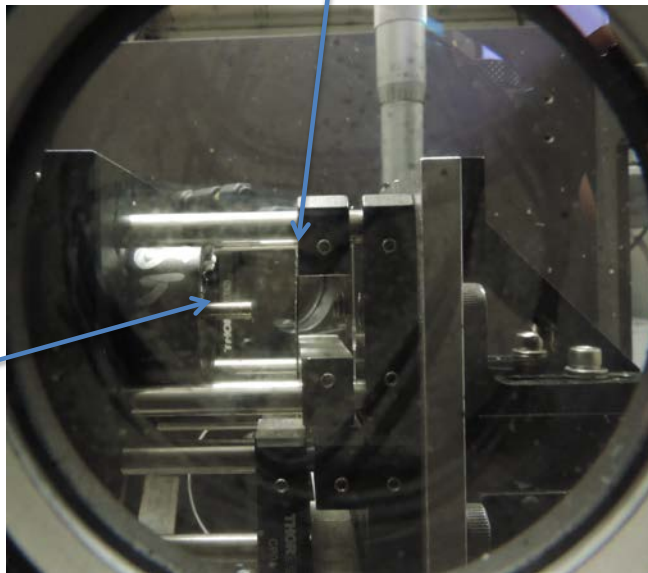

PDV Probe in holder

The camera view of the micro-sandwich and fixture inside the micro-boombox.

- Photonic Doppler Velocimetry (PDV)
 - Technique used to measure the velocity of an interface
- Ultra-high speed Framing Camera
- Streak Camera

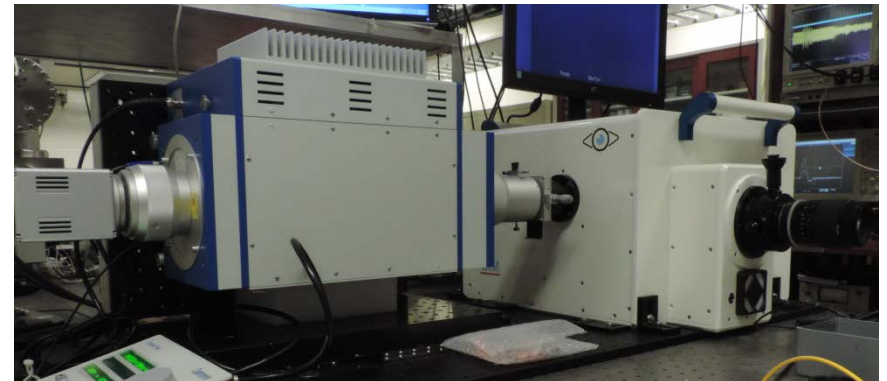
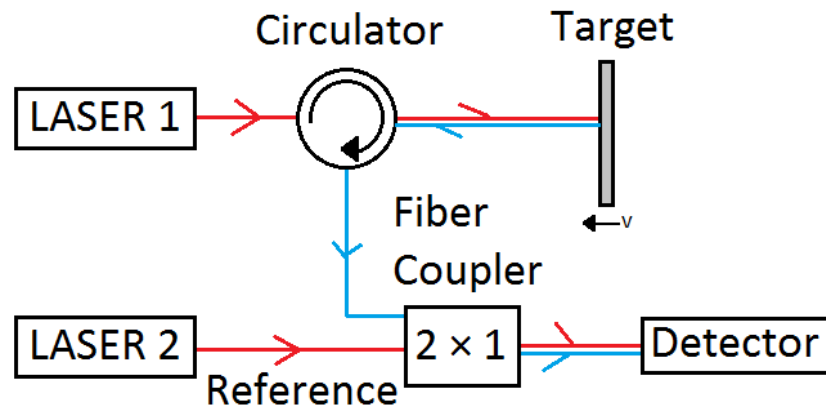

Image of the SIMX (framing) and SC-10 (streak) camera system that were used in the experiment

Photonic Doppler Velocimetry (PDV)

- Laser beam is propagated through a circulator to a probe lens
- Probe lens focuses the beam onto the target
- During detonation, reflected light undergoes a Doppler shift
- Reflected light collected by probe lens and transmitted back to the circulator
- Both Doppler-shifted light and un-shifted light are mixed together via a coupler which generates a beat frequency that is then measured by the optical detector
- Beat frequency is proportional to instantaneous velocity of target



(Left) The basic setup of an upshifted PDV system. Adapted from Ao and Dolan (2010).

([Sargis, et al., 1999](#))
([Maisey and Bowden, 2008](#))

- Chamber rated for small-scale explosives testing
 - Aluminum with polycarbonate windows
- Each box rated based on the largest amount of TNT equivalent explosive that can be safely detonated in the box
- This experiment utilized a micro-boombox with a maximum allowable TNT equivalence of 110 mg

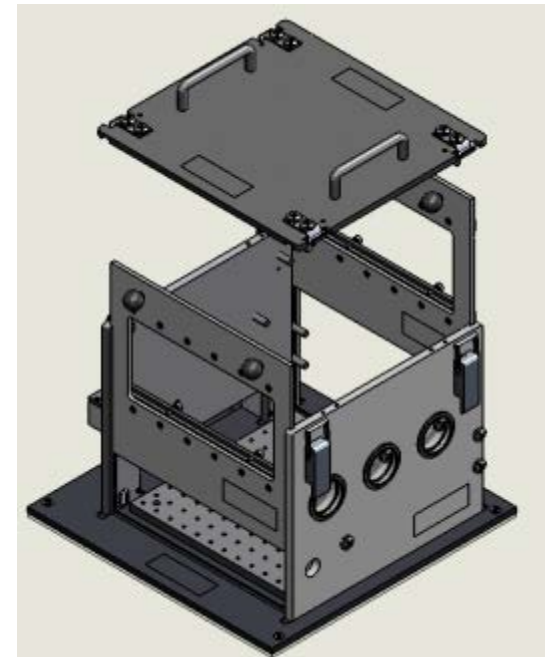

A SolidWorks model of the micro-boombox used in this experiment (Image Courtesy of Sandia National Laboratories).

- The amount of explosive energy for a specific type of explosive is often expressed in an equivalent amount of TNT
- TNT equivalence is a way to relate the potential energy output of different explosives to a known baseline, TNT output
- $TNT_{equiv} = \sum m_{HE} \times \%TNT_{HE}$
- For this case:
- $TNT_{equiv_{sandwich}} = 10 [mg] + l \times w \times t \times \rho \times 112\%$
- $TNT_{equiv_{sandwich}} = 81.2 [mg]$

- Introduction
 - Project Overview
 - Sandwich Test
 - Physical Vapor Deposition
 - Liner Material
 - HNAB
- Experimental
 - Adhesion Layers
 - Diagnostic Equipment
 - Sandwich Assembly
- **Results**
- **Conclusion**

 50.8 μm Thick

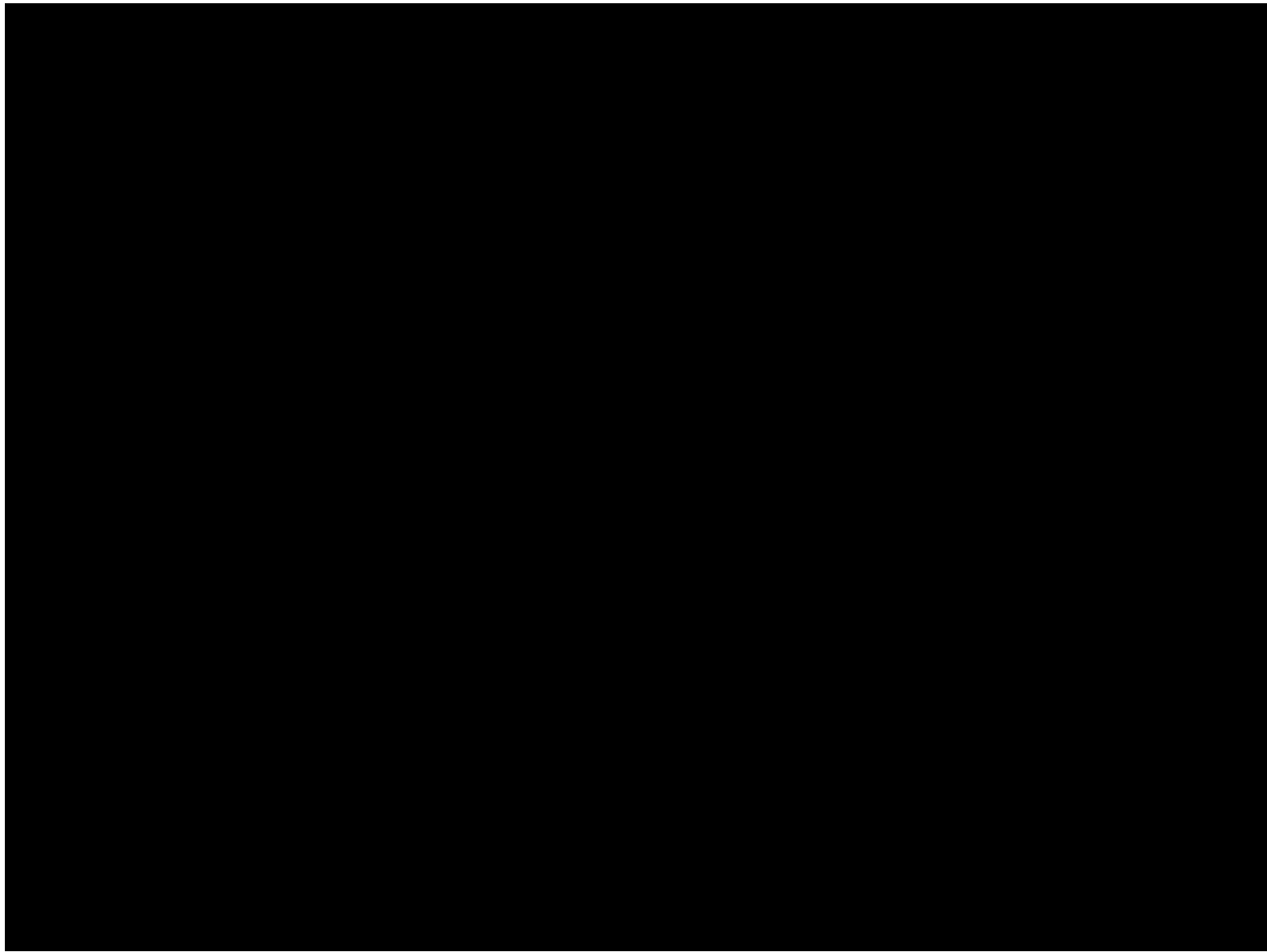

Liner Angle

- Framing camera images used to determine liner angles
- We see differences in liner angles

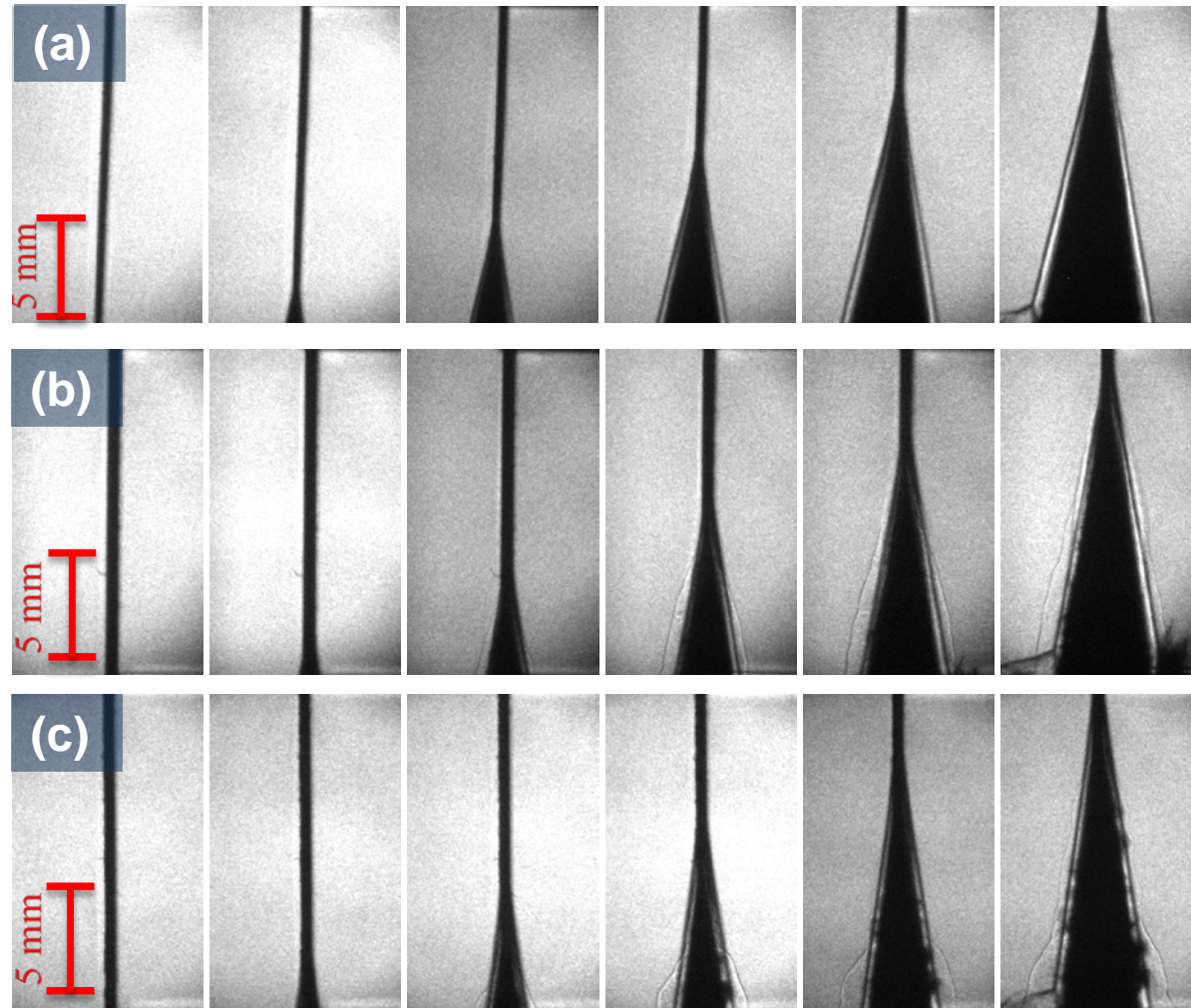

Cross-section view of the (a) 50.8 μm, (b) 76.2 μm, and (c) 101.6 μm tantalum experiment on HNAB micro-sandwich test, 5 ns exposure, 2.4 MHz (1/417 ns). Each frame has a height of about 15 mm.

- Measure liner angle from framing camera images

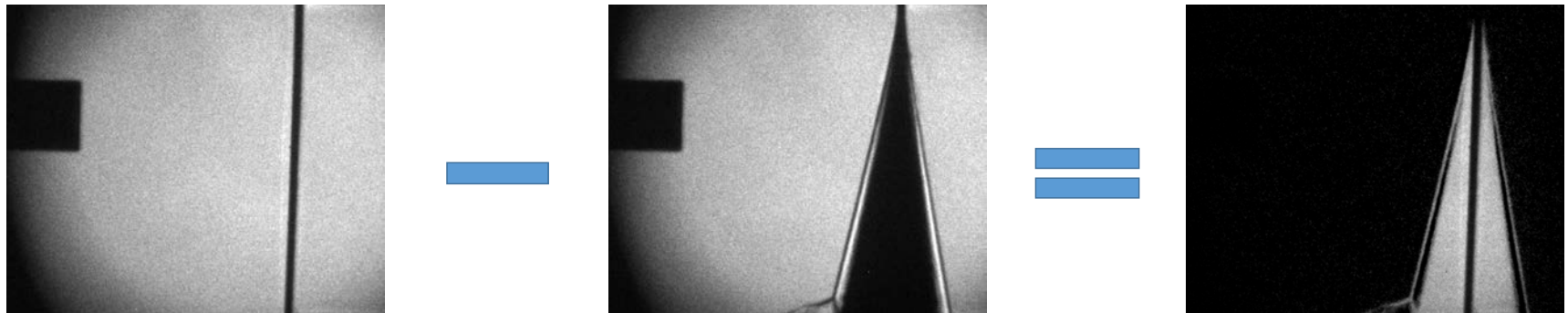

(Above) Pictorial representation of the mathematical process that was performed using Image-Pro Plus software to analyze framing camera images.

Framing Camera Data Analysis

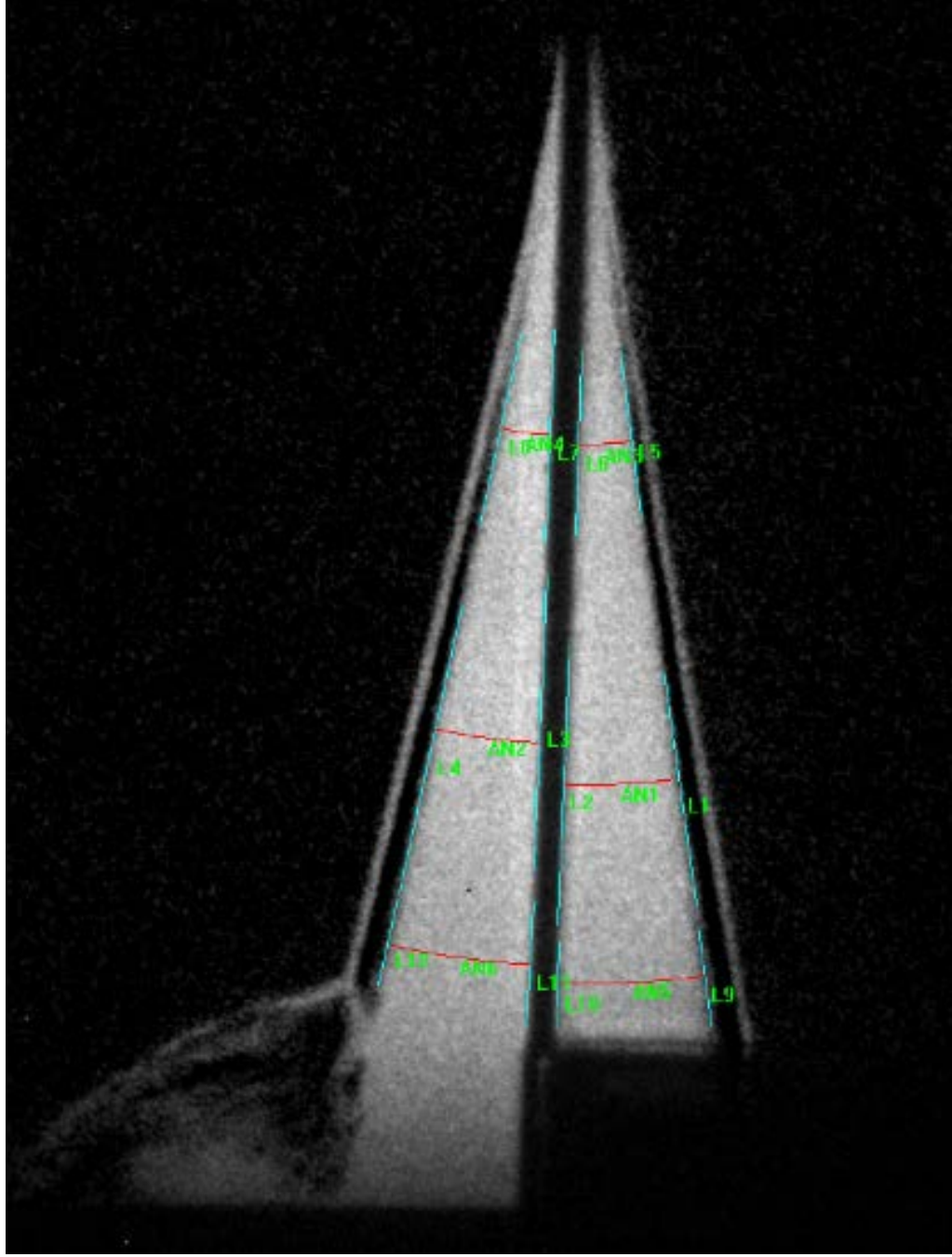

*(Left) Angle
measurements
taken with Image-
Pro Plus software.*

PDV Data Analysis

(Below) PDV data after using pTool for Fourier analysis.

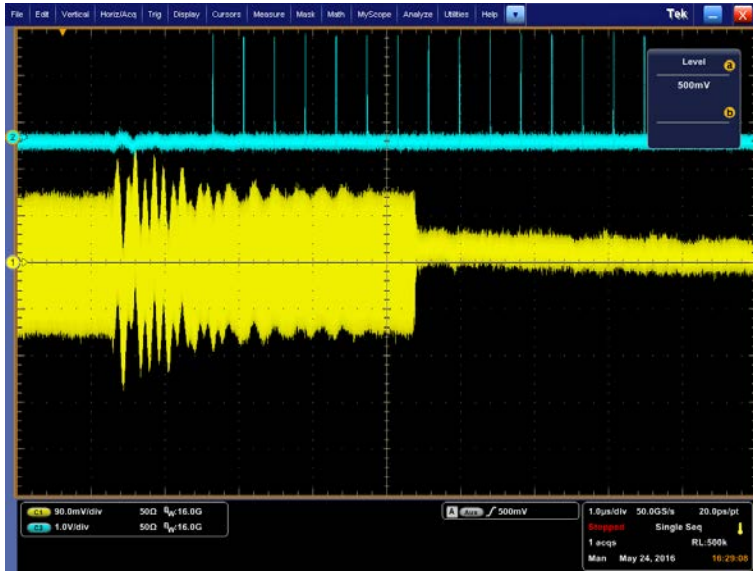

(Above) Raw PDV data.

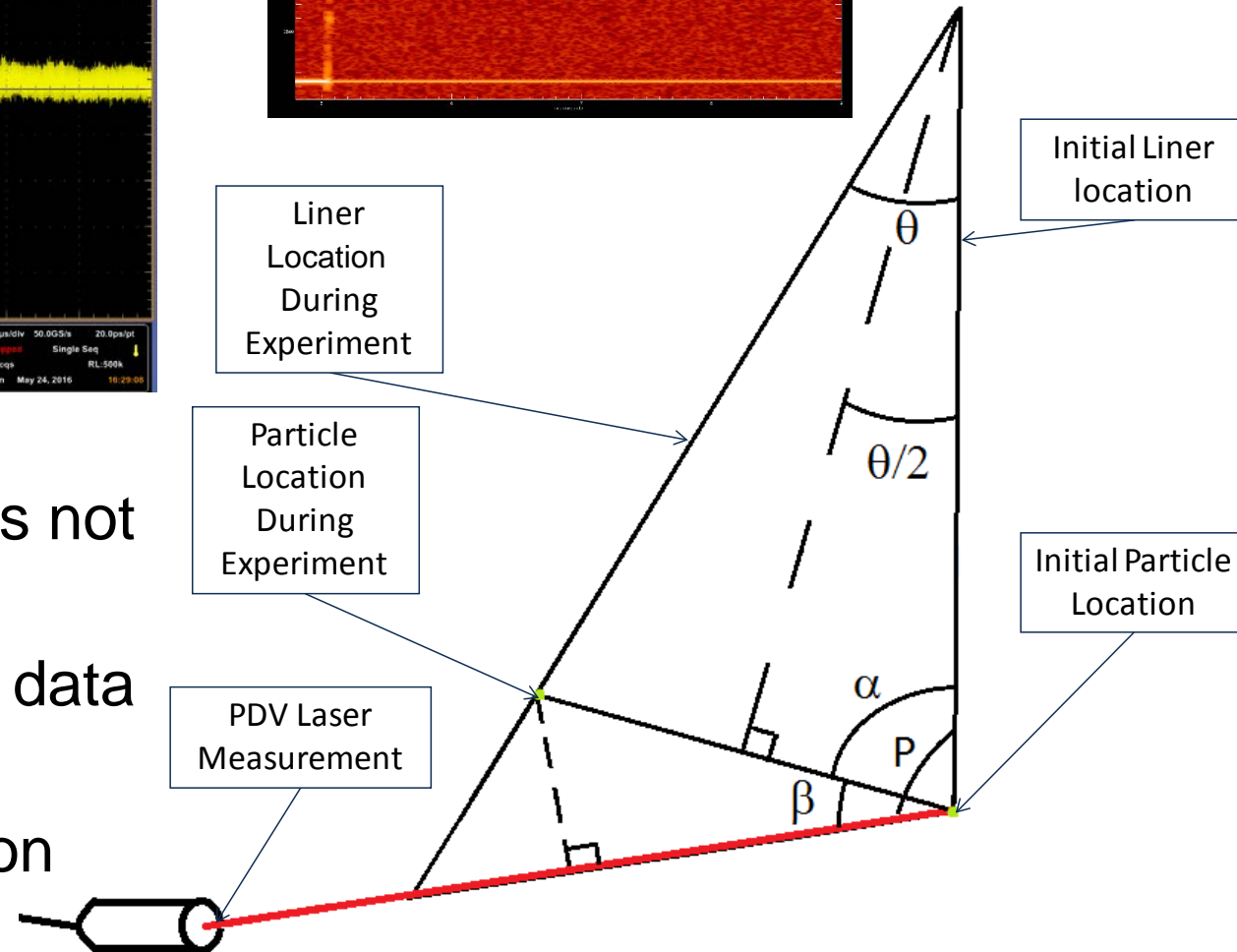
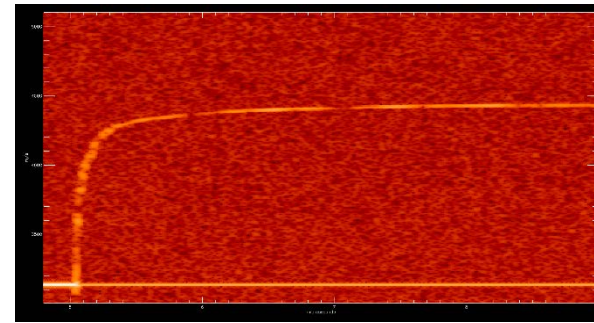

Cartoon of experiment geometry during detonation to aid in PDV analysis.

- Assuming liner does not stretch
- pTool was used for data analysis
- Fourier Transform on PDV scope data

Results 50.8 μm

- Liner Angle:
 - $11.3^\circ \pm 1^\circ$
- Max Material Velocity:
 - $1296.5 \pm 9.7 \text{ m/s}$

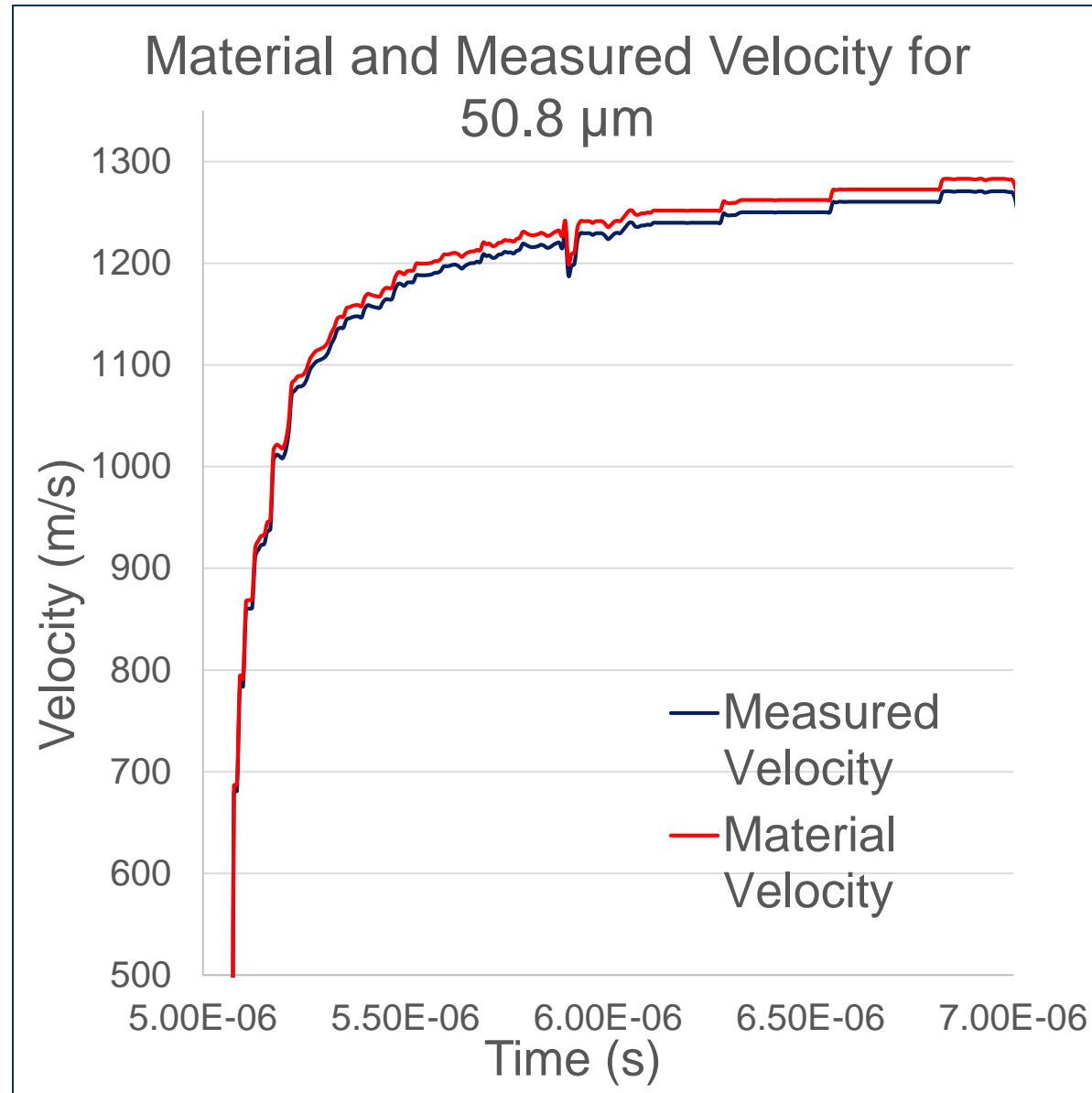

Results 76.2 μm

- Liner Angle:
 - $9.7^\circ \pm 2^\circ$
- Max Material Velocity:
 - $1132.8 \pm 4.1 \text{ m/s}$

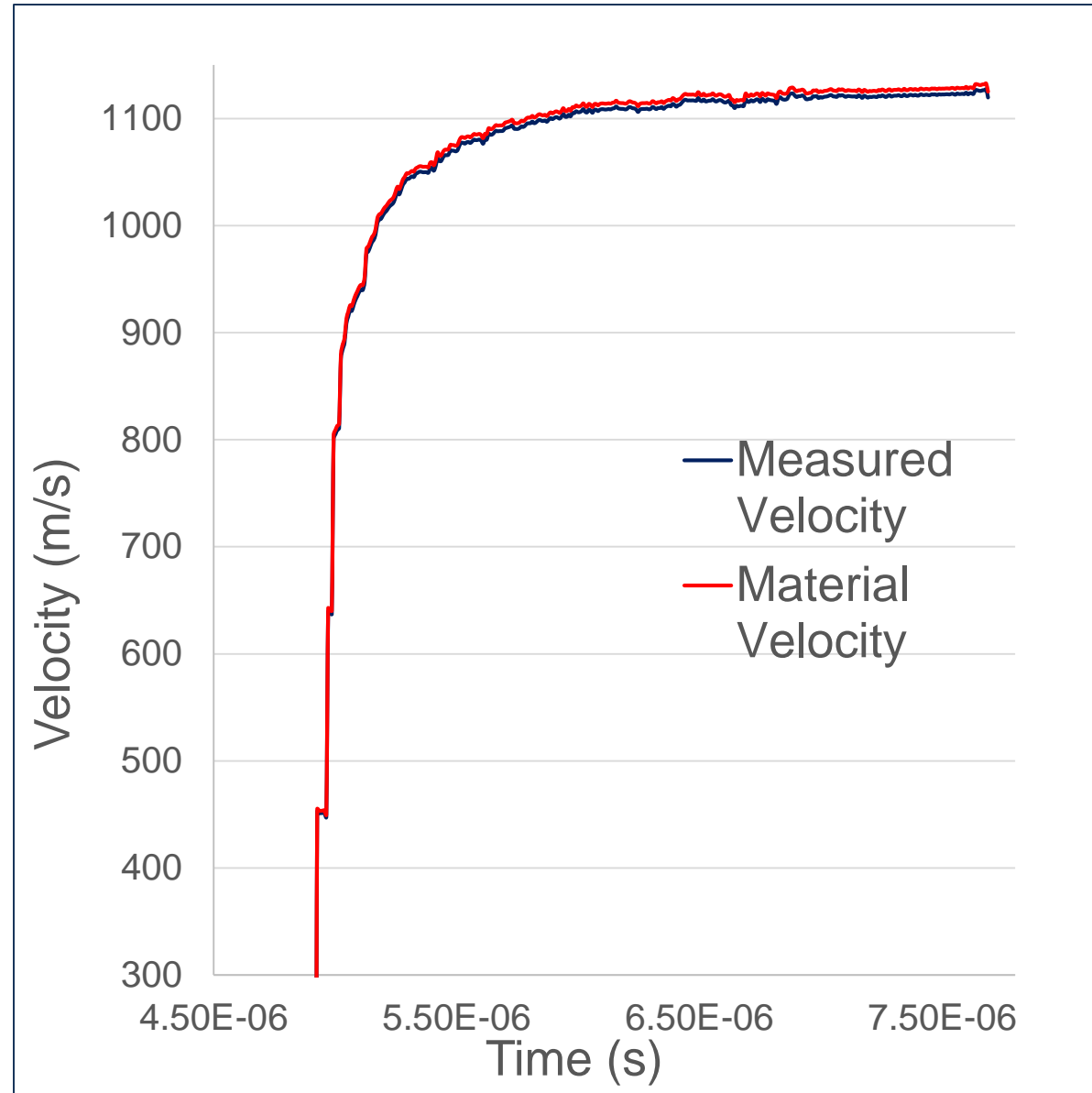

Results 101.6 μm

- Liner Angle:
 - $8.0^\circ \pm 1^\circ$
- Max Material Velocity:
 - 885.1 ± 3.7 m/s

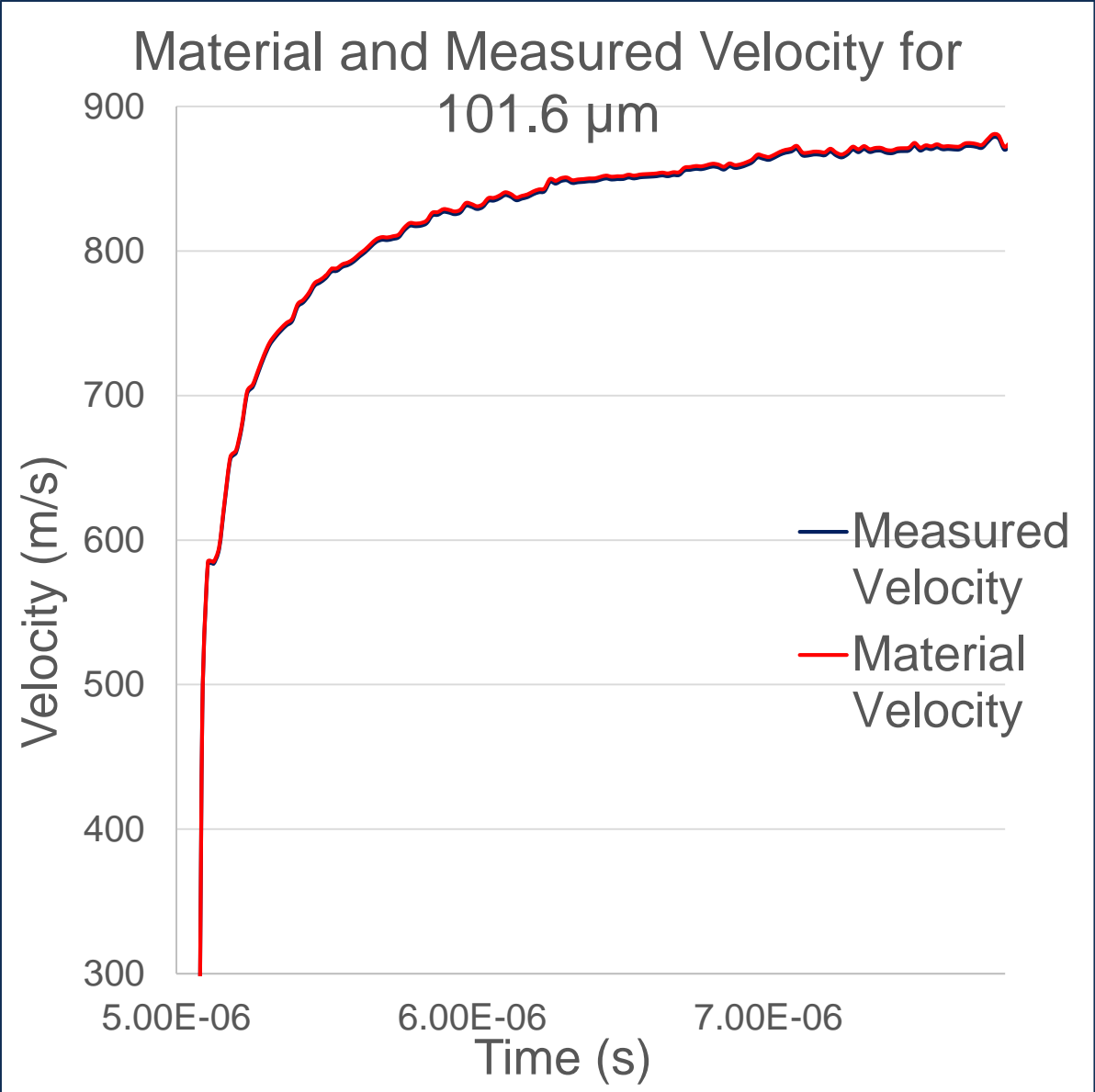

Thickness (μm)	Velocity (m/s)	Liner Angle
50.8 ± 2.5	1297	11.2°
76.2 ± 5.1	1133	9.7°
101.6 ± 1.3	885	8.0°

Data Comparison

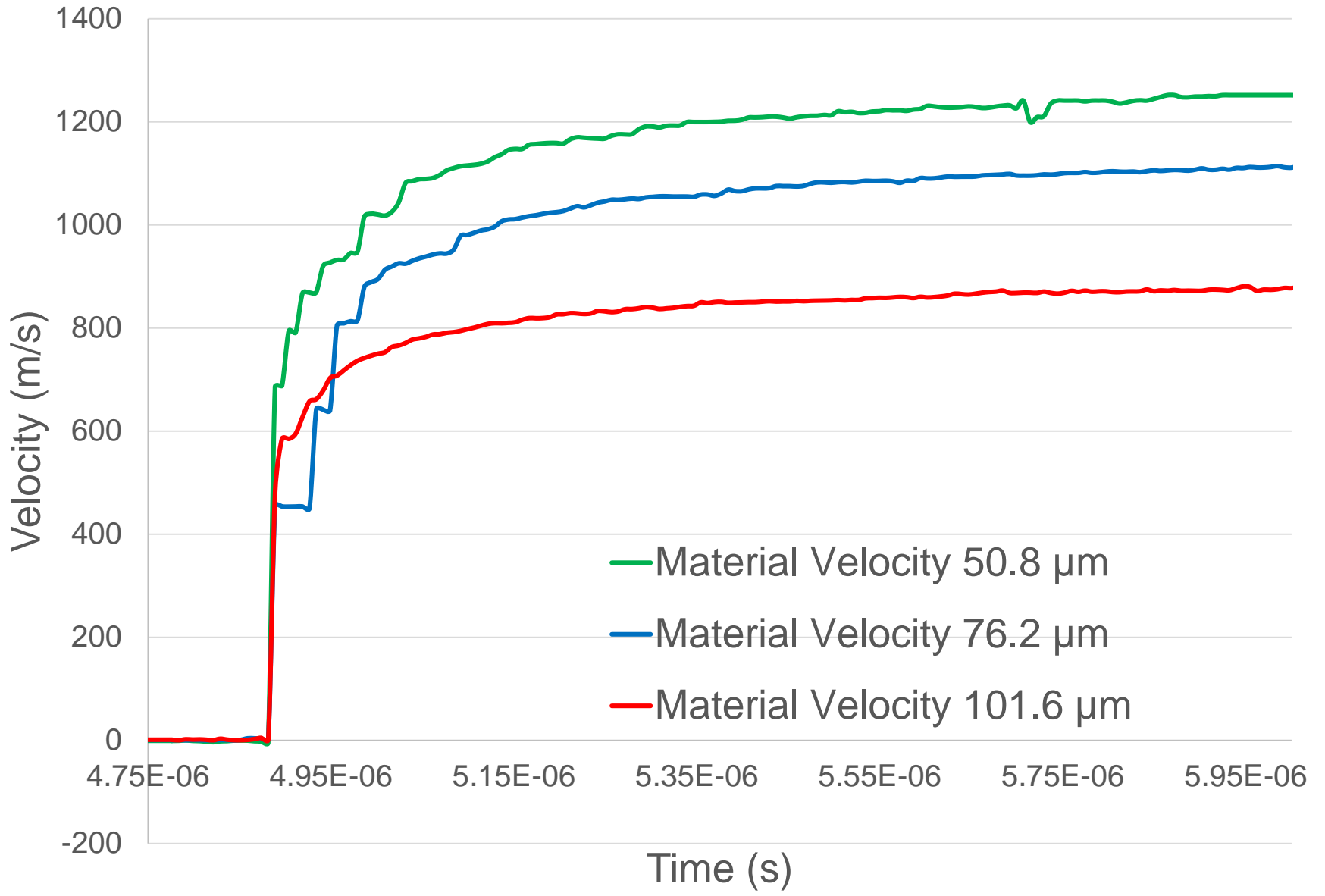



Discussion

- Significance of Results
 - Designed and implemented a new fundamental experiment that provides data for small-scale explosives that will lead to development of EOS
- How the EOS is developed
 - The experiment will be modeled in computer code (CTH) taking EOS input from thermochemical equilibrium code
 - The EOS input is modified to match the experimental data
- How EOS is used
 - Due to the fact that there will be currently no data with confidence to model vapor-deposited HNAB, this experiment will be used to verify and tune CTH model
 - Need ability to model HNAB in CTH

- Introduction
 - Project Overview
 - Sandwich Test
 - Physical Vapor Deposition
 - Liner Material
 - HNAB
- Experimental
 - Adhesion Layers
 - Diagnostic Equipment
 - Sandwich Assembly
- Results
- **Conclusion**



Conclusion

- A micro-sandwich test was successfully developed and used to provide supporting data for vapor-deposited explosives EOS development.
- Vapor-deposited HNAB is a useful model for studying detonation behavior at small scales as it has a uniform microstructure with low surface roughness.
 - These characteristics made HNAB useful for a small-scale version of a sandwich test, the micro-sandwich test.
- The data analysis of the three different thickness of tantalum liners yielded the trend that as the liner thickness increased, the liner angle and material velocities decreased.
 - This result was expected because different thicknesses of any material would have different velocities when undergoing the same amount of pressure and force.
- The data from these experiments will be provided to modelers for EOS development

- Ao, T., & Dolan, D. H. (2010). SIRHEN: A data reduction program for photonic Doppler velocimetry measurements. *Technical Report SAND2010-3628 Sandia National Laboratories.*
- Aslam, T. D., Bdzil, J. B., & Hill, L. G. (2004). *Analysis of the LANL Detonation-Confinement Test.* Paper presented at the Proceedings of the Conference of the American Physical Society Topical Group on Shock Compression of Condensed Matter, Portland, OR.
- Briggs, M. E., Hull, L., & Shinas, M. (2009). *Fundamental Experiments in Velocimetry.* Paper presented at the Proceedings of the Annual Meeting of the American Physical Society Division on Shock Compression of Condensed Matter, Nashville, TN.
- Bruker. (2016). DektakXT Stylus Profiler. 2016, from <https://www.bruker.com/products/surface-analysis/stylus-profilometers/dektak-xt/overview.html>
- Carlson, G. A. (2002). Experimental Errors and Uncertainty. http://www.ece.rochester.edu/courses/ECE111/error_uncertainty.pdf
- Cooper, P. W. (1996). Section IV: Detonation *Explosives Engineering* (pp. 251-313). New York: Wiley-VCH.
- Curtiss-Wright. (2016). What is the Parylene Coating process?
- Dobratz, B. M., & Crawford, P. C. (1985). LLNL Explosives Handbook – Properties of Chemical Explosives and Explosive Simulants, 'HNAB'. Lawrence Livermore National Laboratory: Lawrence Livermore National Laboratory.
- Graeber, E. J., & Morosin, B. (1974). The crystal structures of 2,2',4,4',6,6'-hexanitroazobenzene (HNAB), forms I and II *Acta Crystallographica Section B* (Vol. 30, pp. 310-317).
- Hamamatsu. (2015). Guide to Streak Cameras. 2015, from http://www.hamamatsu.com/resources/pdf/sys/SHSS0006E_STREAK.pdf
- Held, M. (1983). TNT - Equivalent. *Propellants, Explosives, Pyrotechnics*, 8(5), 158-167.
- Hertel Jr., E. S., Bell, R. L., Elrick, M. G., Farnsworth, A. V., Kerley, G. I., McClain, J. M., . . . Yarrington, L. (1992). CTH: A Software Family for Multi-Dimensional Shock Physics Analysis. Sandia National Laboratories: Sandia National Laboratories.

- Hill, L. G. (2001, June 24-29). *Development of the LANL Sandwich Test*. Paper presented at the Proceedings of the Conference of the American Physical Society Topical Group on Shock Compression of Condensed Matter, Atlanta, GA.
- Jensen, B. J., Holtkamp, D. B., Rigg, P. A., & Dolan, D. H. (2009). Accuracy Limits and Window Corrections for Photon Doppler Velocimetry. *Journal of Applied Physics*, 101(1), 013523.
- Jones, H., & Miller, A. R. (1948). The Detonation of Solid Explosives: The Equilibrium Conditions in the Detonation Wave-Front and the Adiabatic Expansion of the Products of Detonation. *Proceedings of the Royal Society of London A: Mathematical, Physical and Engineering Sciences*, 194(1039), 480-507. doi: 10.1098/rspa.1948.0093
- Knepper, R. (2014). Physical Vapor Deposition of HNAB. In *Effusion cell HNAB* (Ed.). Newry, ME: Gordon Research Conference.
- Knepper, R., Browning, K., Wixom, R. R., Tappan, A. S., Rodriguez, M. A., & Alam, M. K. (2012). Microstructure Evolution During Crystallization of Vapor-Deposited Hexanitroazobenzene Films. *Propellants, Explosives, Pyrotechnics*, 37, 459 – 467. doi: 10.1002/prop.201200013
- Knepper, R., Marquez, M. P., & Tappan, A. S. (2014, July 13 – 18). *Effects of Confinement on Detonation Behavior of Vapor-Deposited Hexanitroazobenzene Films*. Paper presented at the 15th International Detonation Symposium, San Francisco, CA.
- Kuhl, A. L. (2010). *Thermodynamic States in Explosion Fields*. Paper presented at the 14th International Detonation Symposium, Coeur d'Alene, Idaho, United States. <https://e-reports-ext.llnl.gov/pdf/388882.pdf>
- LosAlamosNationalLaboratory. (2008). pTool Photon Doppler Velocimetry Analysis Tool. In NSTec (Ed.), *User Manual*: Los Alamos National Laboratory.
- LPKF:Laser&Electronics. (2016). ProtoLaser U3. from http://www.lpkfusa.com/products/pcb_prototyping/machines/protolaser_u3/
- Maisey, M. P., & Bowden, M. D. (2008). *Characterization of Detonator Performance Using Photonic Doppler Velocimetry*. Paper presented at the Optical Engineering+ Applications, San Diego.
- OMEGA-Laser-Facility. Streak Camera Overview. *Training Material*. <http://opto-mech.ile.rochester.edu/Training%20Material/General/streak%20cameras.pdf>
- Optronis. (2010). SC-10 Streak Camera Main Unit. from <http://www.optronis.com/de/support/downloads/optoscope/datenblaetter-sc-10.html>

- Polk, J. F. (1984). Determination of the equation of state of explosive detonation products from the cylinder expansion test. Aberdeen Proving Ground, MD: US Army Armament Research and Development Center Ballistic Research Laboratory.
- Richards, D. W., Kramer, M. P., House, J. W., & De Angelis, R. J. (2003). Annealing studies of pure and alloyed tantalum employing rocking curves. *Advances in X-Ray Analysis*, 46, 285-290.
- Sargis, P. D., Molau, N. E., Sweider, D., Lowry, M. E., & Strand, O. T. (1999). Photonic Doppler Velocimetry. In L. N. Laboratory (Ed.): Lawrence Livermore National Laboratory.
- Specialised-Imaging. Detailed Specifications SIMX. from www.specialised-imaging.com
- Tappan, A. S., Wixom, R. R., & Knepper, R. (2014, July 13 – 18). *Critical Detonation Thickness in Vapor-Deposited Hexanitroazobenzene (HNAB) Films with Different Preparation Conditions*. Paper presented at the 15th International Detonation Symposium, San Francisco, CA.
- Tappan, A. S., Wixom, R. R., & Knepper, R. (2015, June 14 – June 19). *Geometry Effects on Detonation in Vapor-Deposited Hexanitroazobenzene (HNAB)*. Paper presented at the 19th Biennial APS Topical Conference on Shock Compression of Condensed Matter, Tampa, FL.
- Thorlabs. (2016). 50-1550A-APC - Single Mode GRIN Fiber Collimator, 1550 nm, FC/APC Connector. 2016, from <http://www.thorlabs.us/thorproduct.cfm?partnumber=50-1550A-APC>
- Valenzuela, A. R., Rodriguez, G., Clarke, S. A., & Thomas, K. A. (2007). Photonic Doppler Velocimetry of Laser-Ablated Ultrathin Metals. *Review of Scientific Instruments*, 78, 013101.
- Weseloh, W. N. (2014). JWL in a Nutshell. In L. A. N. Laboratory (Ed.): Los Alamos National Laboratory.
- Wharton, R. K., Formby, S. A., & Merrifield, R. (2000). Airblast TNT Equivalence for a Range of Commercial Blasting Explosives. *Journal of Hazardous Materials*, 79(1), 31-39.
- Wolfs, F. L. H. (2004). Error Analysis. *Department of Physics and Astronomy*. 2016, from http://teacher.nsl.rochester.edu/phy_labs/AppendixB/AppendixB.html

The End

Backup/Extra Slides

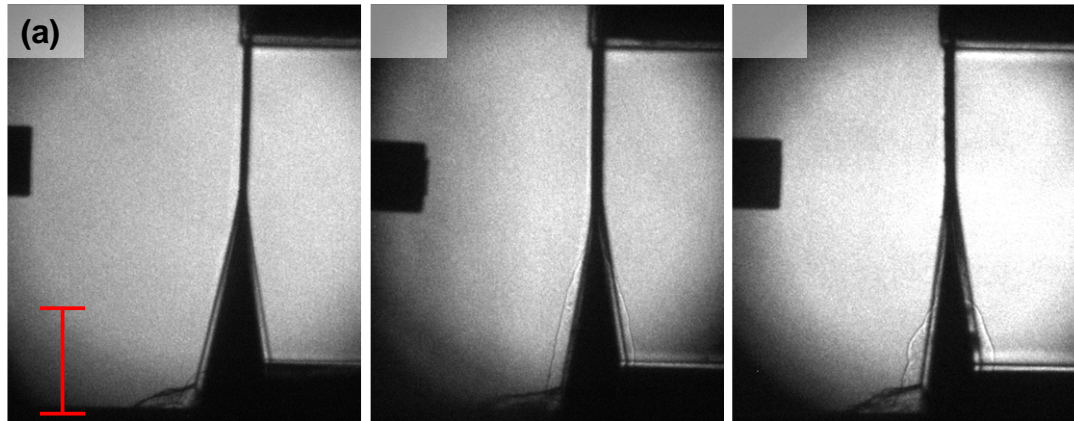

Cross-section view of the micro-sandwich of the (a) $50.8 \mu\text{m}$ (2 mil), (b) $76.2 \mu\text{m}$ (3 mil), and (c) $101.6 \mu\text{m}$ (4 mil) thick tantalum experiment on HNAB micro-sandwich test, 5 ns exposure, 2.4 MHz (1/417 ns).

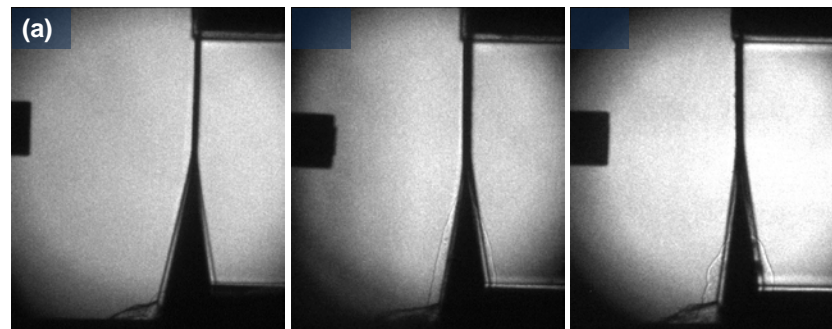

Annealing of Tantalum

- Cutting process damaged substrates
- Needed flat substrates to prevent HNAB from Cracking
- Annealing took place

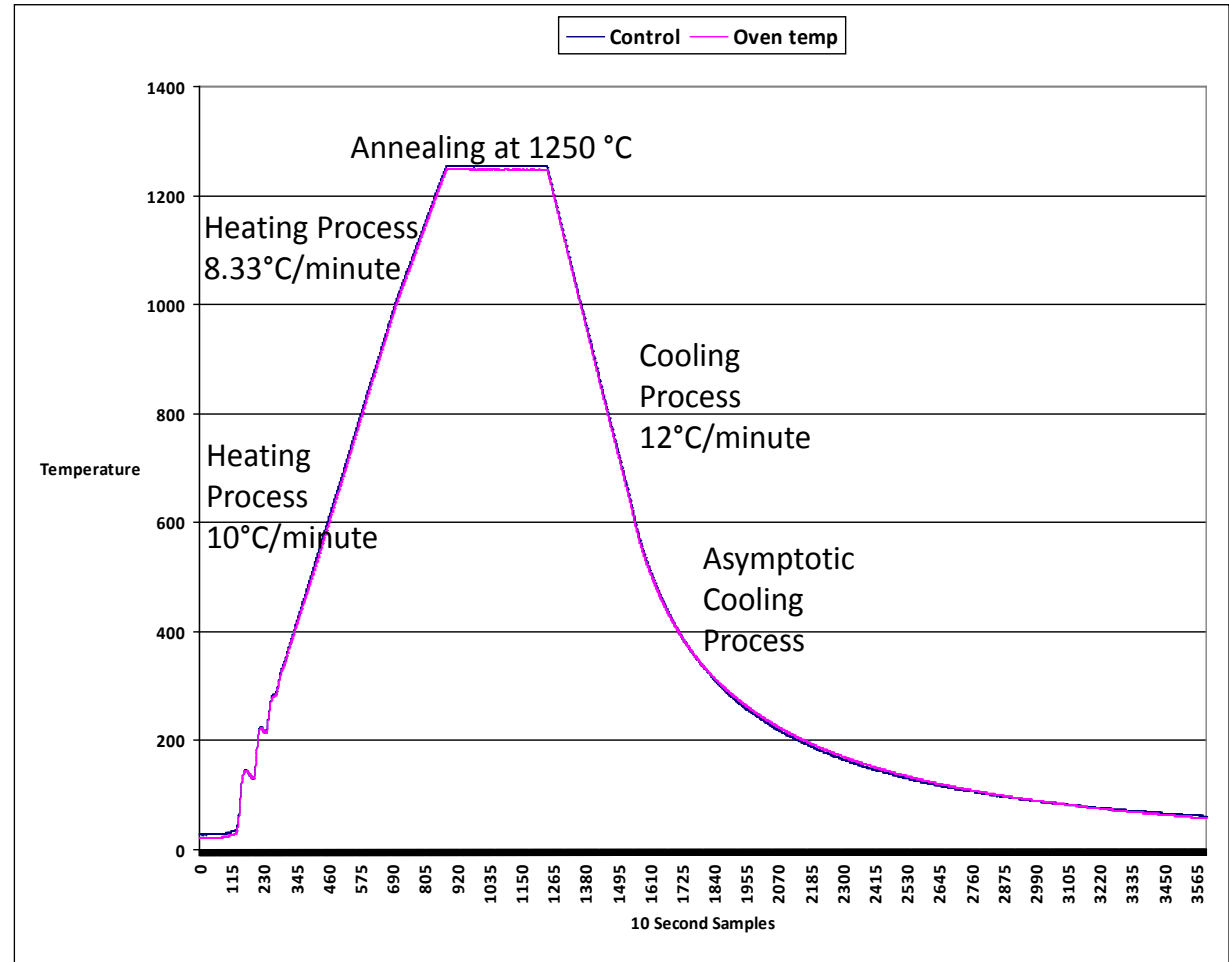

Raw Data

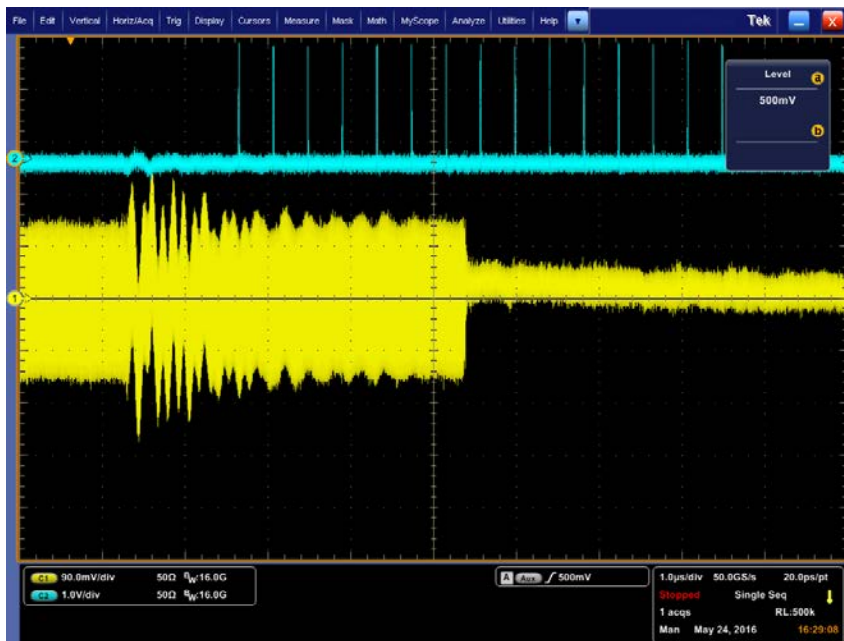

After Fourier Transform

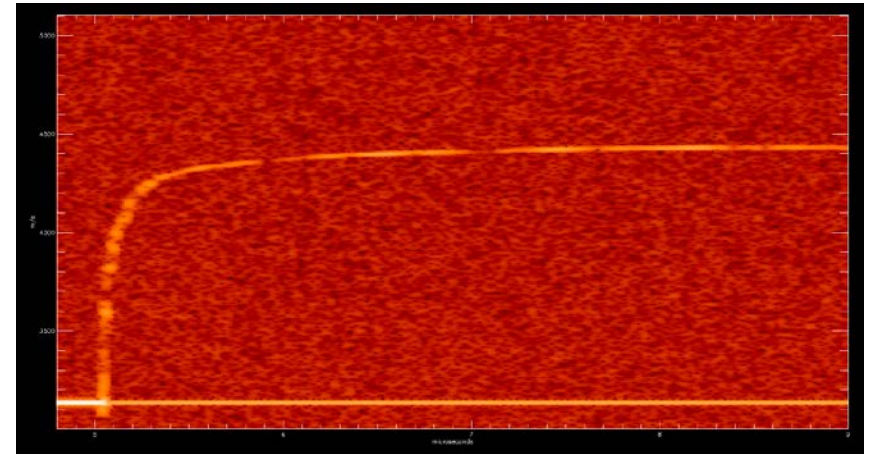

- pTool was used for data analysis
- Fourier Transform on PDV scope data

