

Exceptional service in the national interest

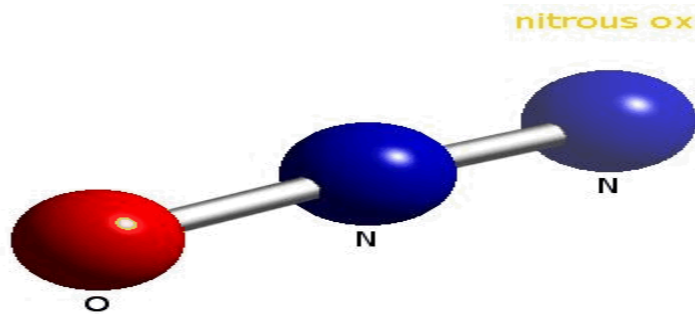

Nitrous Oxide an Overview

Mark Grubelich

mcgrube@sandia.gov

Sandia National Laboratories

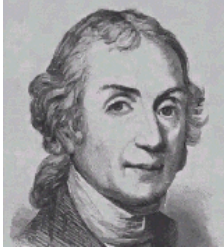

History



- First discovered
 - 1772 Joseph Priestly
- Recreational use or scientific investigation?
 - 1799, Sir Humphry Davy (1778-1829)
 - “The experiments quickly increased in frequency and also intensity”
- Anesthesia
 - 1840’s Horace Wells, modern dental/medical Anesthesia
 - George Poe, Trenton NJ USA, liquefied N₂O, 1883 large dental supplier
- Propulsion
 - 1935 Mono prop > nitrous oxide & anhydrous ammonia (green propulsion)
 - Working with I.G. Farben, Otto Lutz
 - 1937 Hybrid > nitrous oxide & coal (green propulsion)
 - Burning tests at I.G. Farben by L. Andrussow, O. Lutz and W. Noeggerath.
 - Thrust 10,000 nt, propellants: Coal and gaseous nitrous oxide.

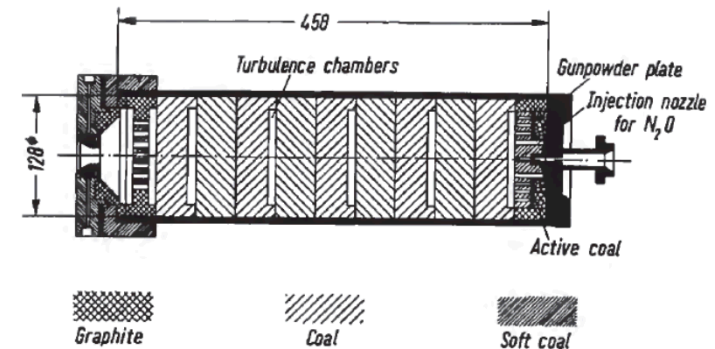

History

- Aircraft super performance (thru-WW2)
 - 100% power increase documented
 - Refrigerated liquid use (-90 C)
 - Anti-detonation fluid (cooled intake charge)
 - GM1
 - Etcetera
- Successful operationally

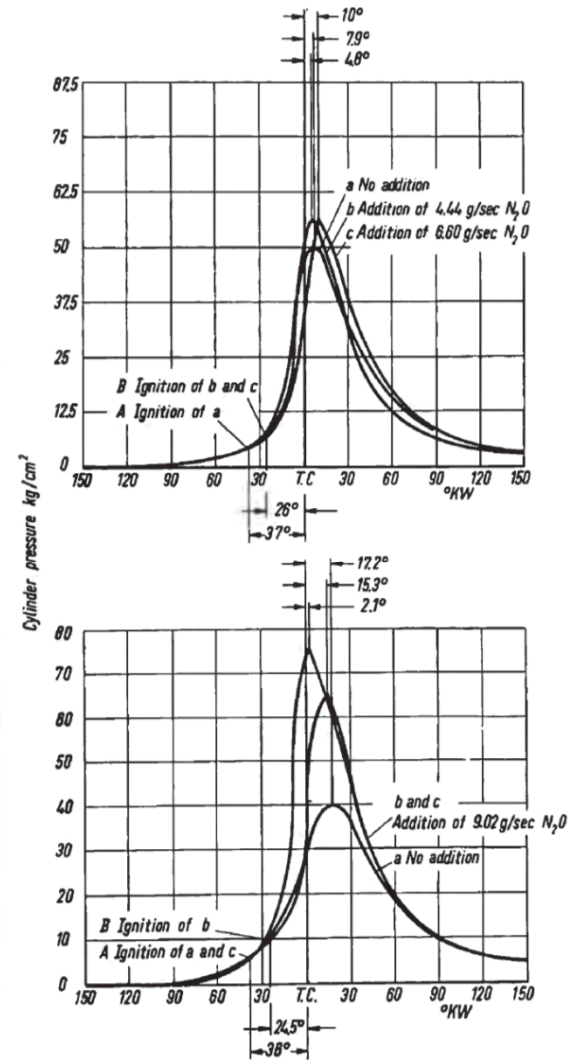
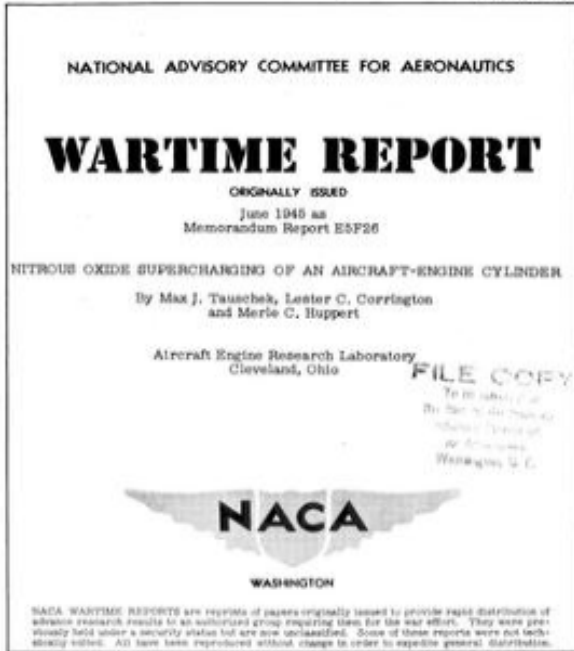
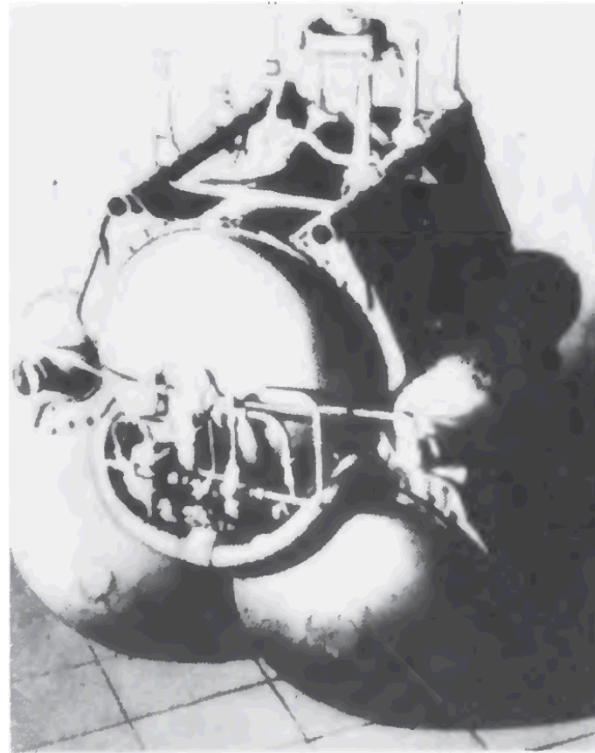

FIGURE 7.—Pressure-time diagrams (T. C. = top center, °KW = crankshaft angle).





History

- Automotive applications
 - Consumer and racing use (1000 HP gains)
- Amateur rocketry, late 1980's +
 - Basis for almost all hobbyist hybrid rocketry
 - Eliminated shipping and storage problems for non-professional rocketry
- Modern aerospace applications
 - 1940's-50's freezing point depressant
 - 1961 Texaco N₂O-carbon patent (?)
 - 1988/89 JHUAPL demonstrates N₂O- HTPB- Al hybrid
 - Bulk mode instabilities and screech
 - Proving that hybrids engines can embody the worst of both solids and liquids!
 - 1990-today Amroc, Space Development, Surrey Satellite, Sierra Nevada, Scaled Composites, Environmental Aero Sciences, Orbitec, Virgin Galactic.
 - Robust commercial suborbital flight hybrids engines

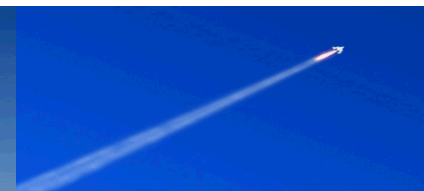

The Good and the Bad

- Stable liquefied gas under pressure
 - +Storage properties
 - -Solvent (de-cafeinater explosion)
 - +Self pressurizing but, not recommended
 - -/+Large pressure-density change with temperature
 - -/+Regenerative cooling, possible but risky...
- Monopropellant
 - - Catalytic decomposition, gas phase, liquid, low mass flux
- Bipropellant
 - +Wide flat MR (O/F), exothermic decomposition
 - Chemical steam generator with ammonia!
 - +/- I_{sp} relatively independent of fuel; $\sim 250-275 > 325s$
 - Mono-props can increase density impulse (NM, etc.)
 - -Non-hypergolic
 - Chemical ignition possible with TEA/TEB, Li, SiH_4
 - Pre-mixed or pilot ignition
- Hybrid
 - +++flight proven!

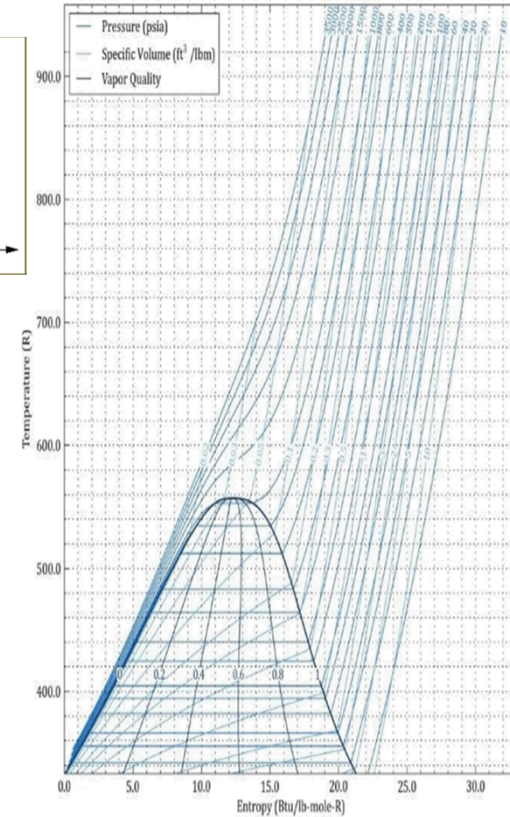
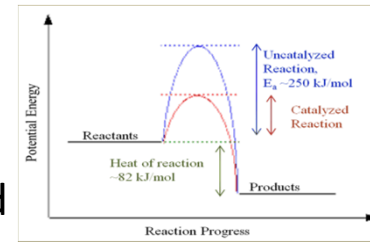

Nitrous oxide & Ethylene testing

- High pressure bi-prop hard start testing (Zucrow Laboratories at Purdue University)
 - DDT event with hot wire ignition; overdriven detonations observed
 - Tremendous pressure spikes (250psi >>30,000 psi!)

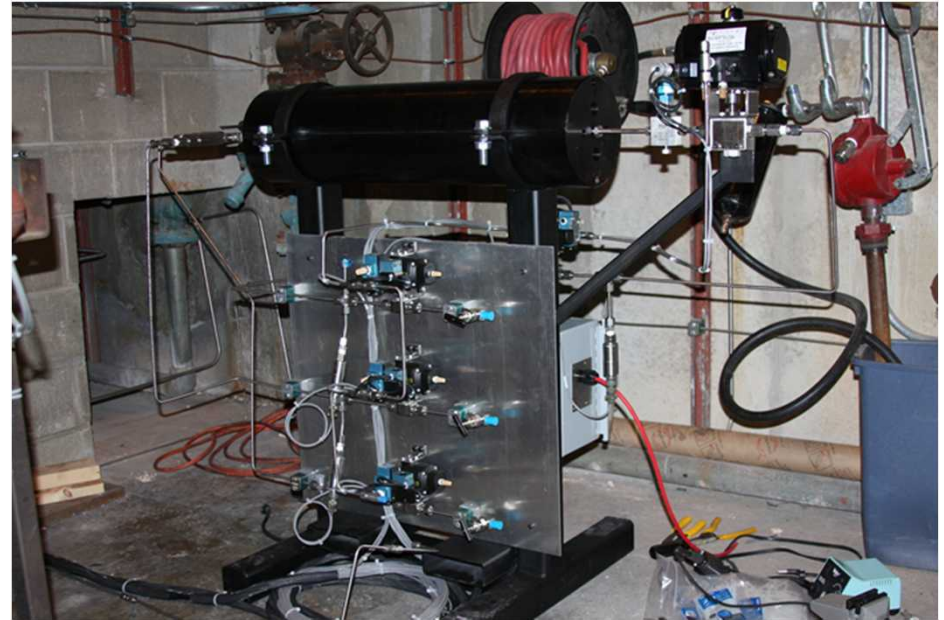

The path forward

- Excellent academic propellant
 - Possible cold flow with CO₂ as a surrogate
 - Readily available
 - Simple pressure vessel tankage
 - Handle like GOX/LOX, cleanliness important
 - Supplemental pressure feed, not self pressurizing
- Bi-prop design
 - Ground up facility
 - Fuel, ethanol (no “hard start”, “hard stop” or DDT)

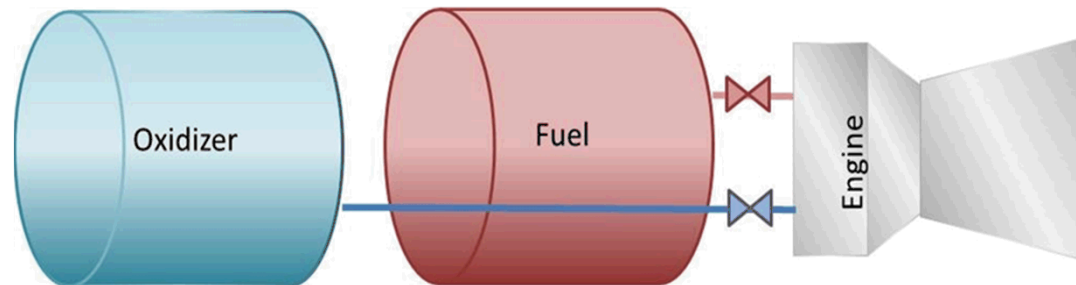

- Design and construct a liquid-fueled rocket engine test facility:
 - N_2O -ethanol fuel mixtures
 - Thrust of less than 500 lbs
 - Pressure fed fuel and oxidizer delivery system
- Research efforts:
 - Evaluate fuel-oxidizer performance
 - Develop “green” systems
 - Optical diagnostics for rocket nozzle exhaust measurements

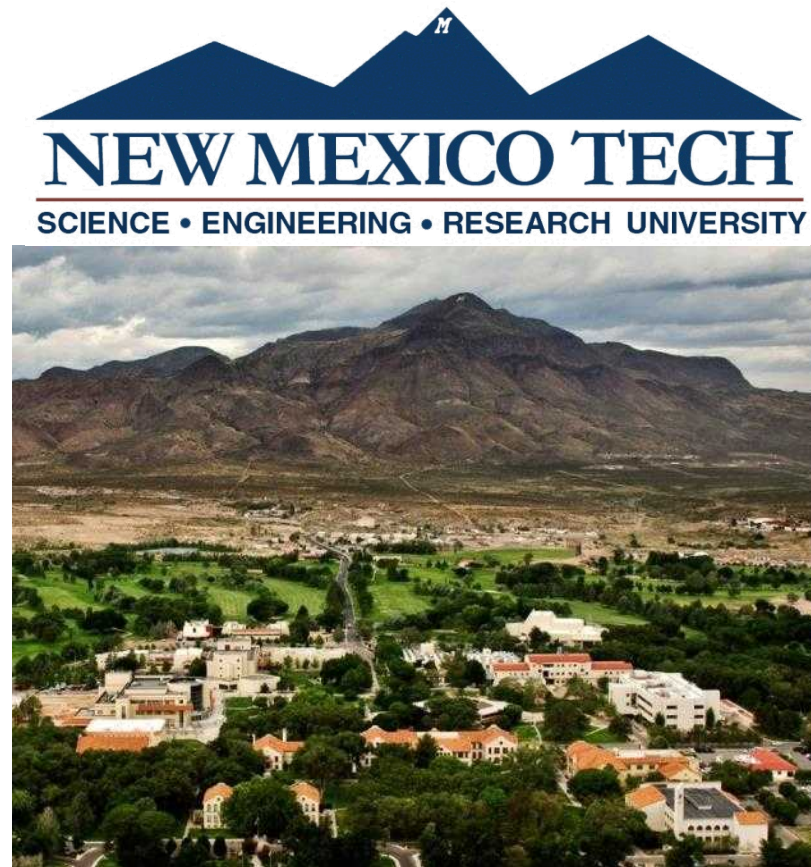

Rocket test stand design and construction Sandia National Laboratories

- Designed by undergraduate students design class
- Variable mounting points to allow different engines and future research efforts
- To be installed at a site on the Energetic Materials Research and Testing Center (EMRTC) adjacent to New Mexico Tech campus

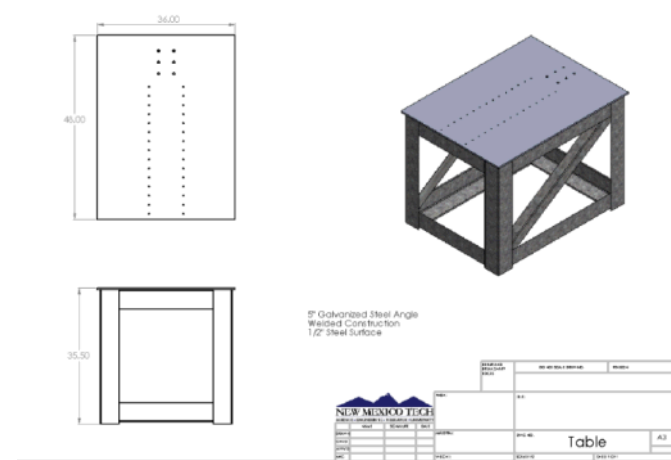

Rocket engine design

- Current MS thesis project
- Modular design
 - Impinging jet injector plate
 - 2" diameter, 8" long combustor section
 - ~250 lbs. thrust nominal
- Propane/oxygen torch ignition system

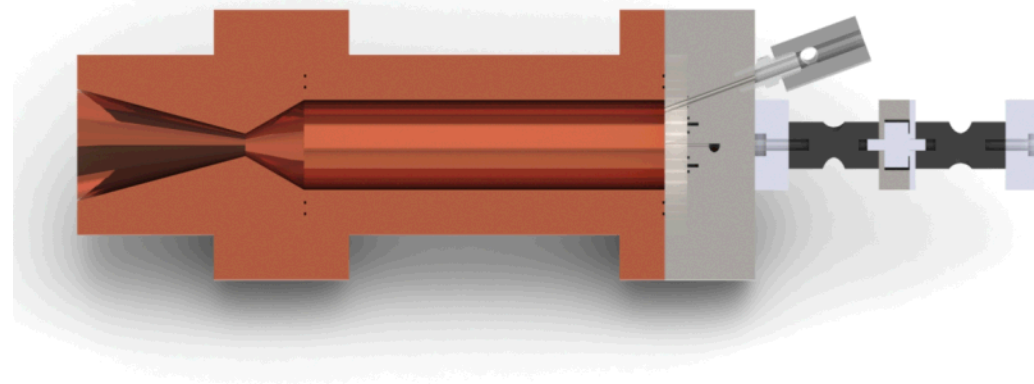
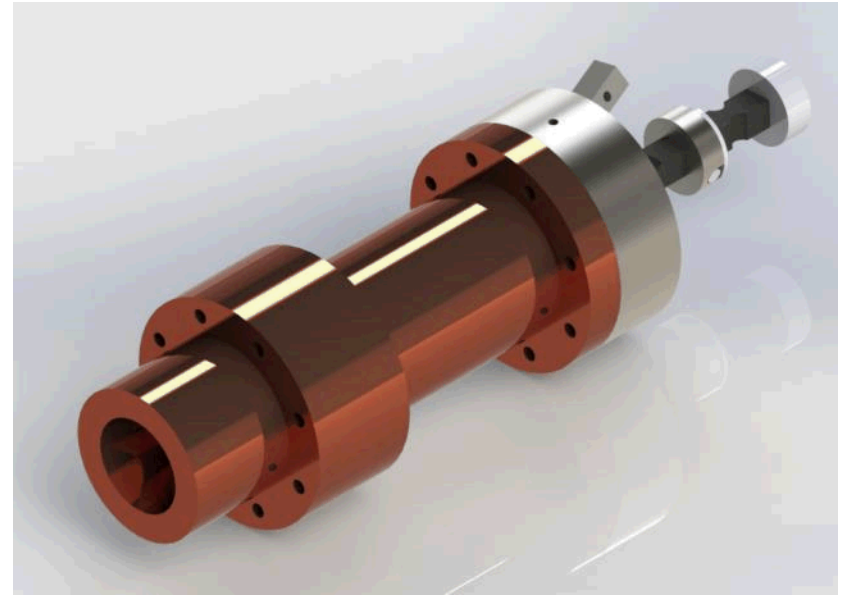

Engine test system

- Blow-down delivery of N₂O and ethanol
- Maximum system working pressure 1800 psi
- Propellant flow rates controlled via cavitating venturists

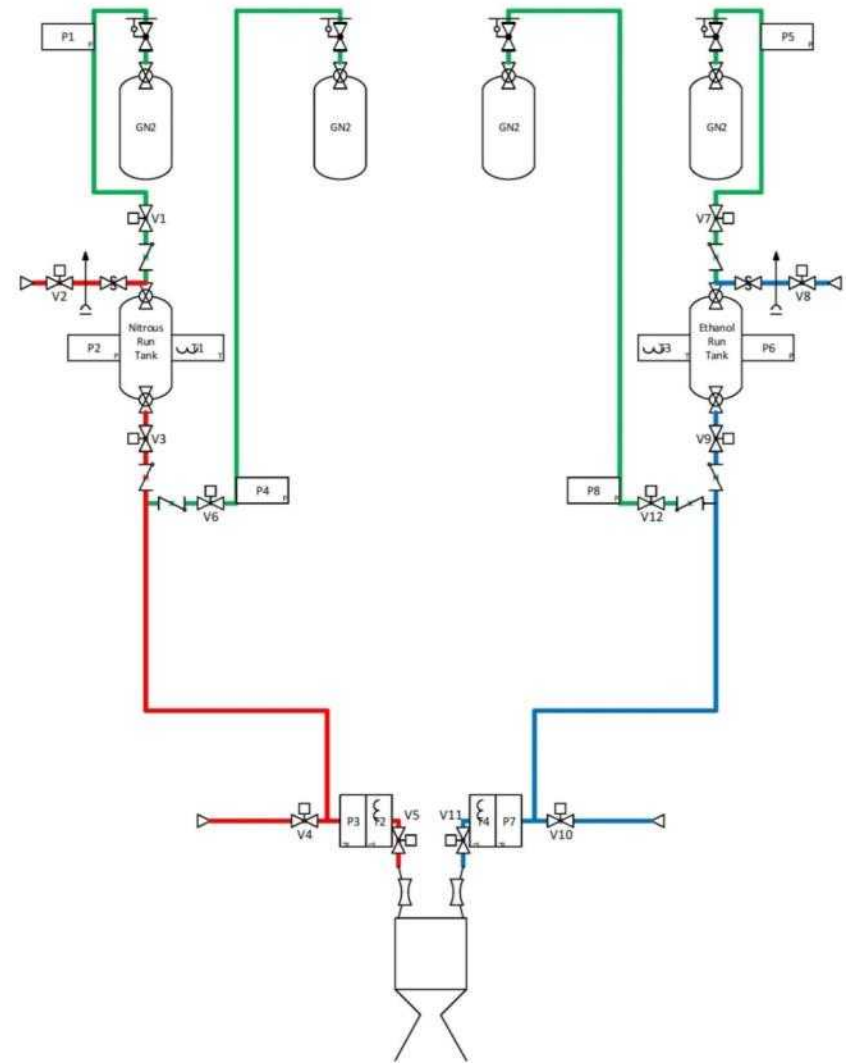

Calculated Performance N₂O Ethanol

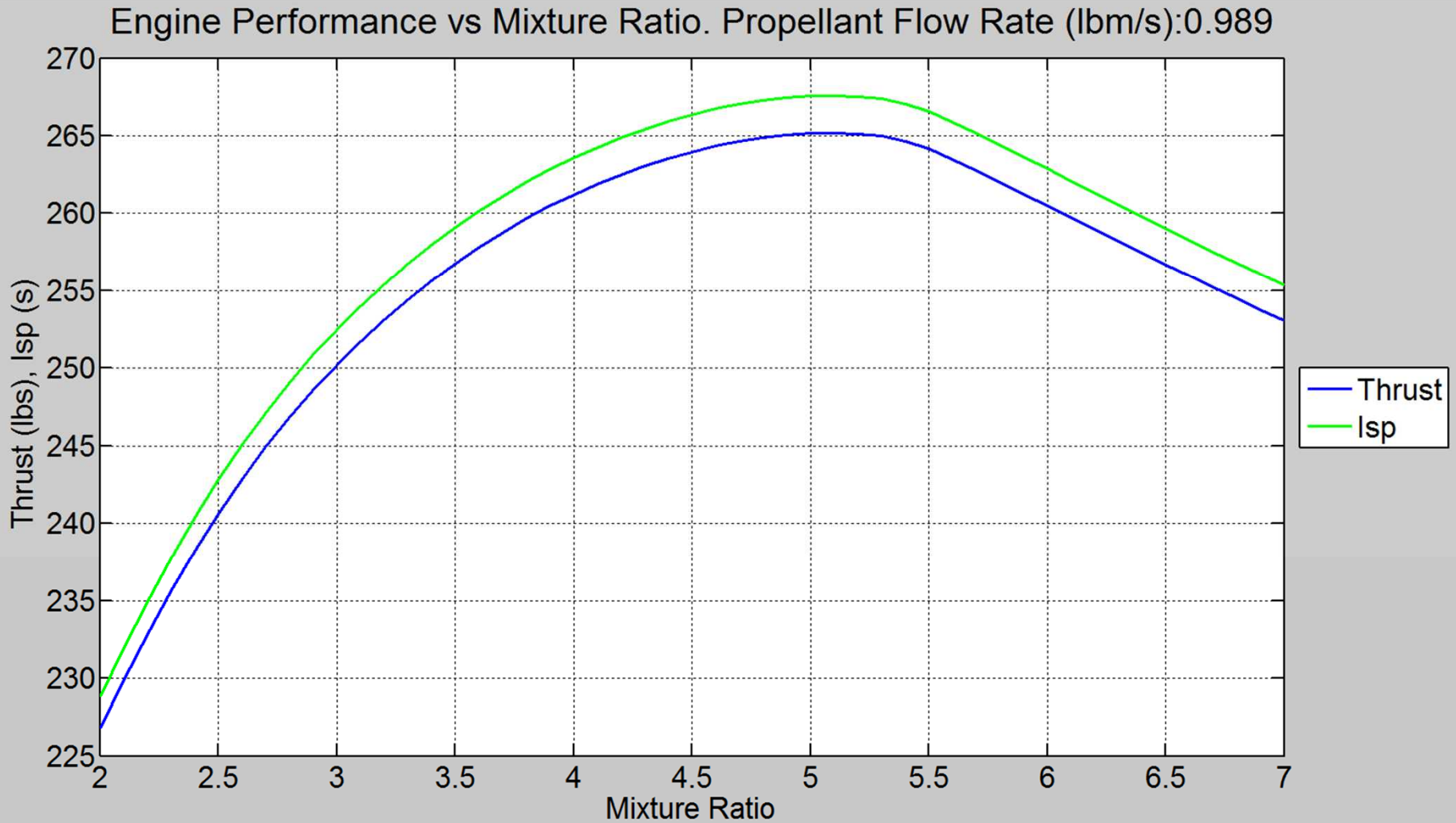

Engine performance as a function of mixture ratio for 1000 psi chamber pressure at MR 4.5

Engine Performance vs Mixture Ratio. Propellant Flow Rate(lbm/s):0.989

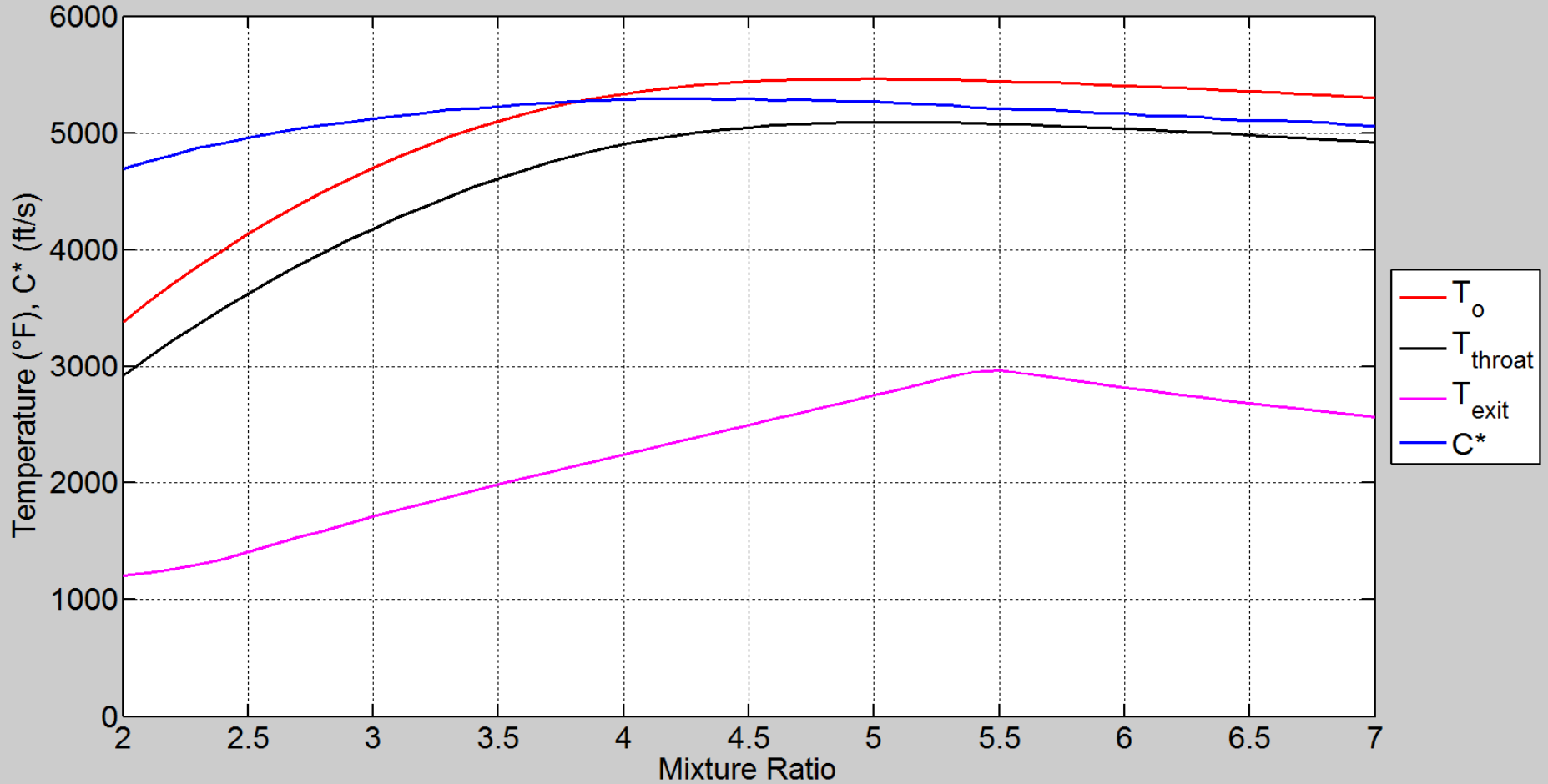

Safety- Thermal / Contamination / Adiabatic compression



“Nitrous Oxide Trailer Rupture”, July 2, 2001, The Netherlands, Eindhoven; CGA Seminar, “Safety and Reliability of Industrial Gases, Equipment and facilities”, Konrad Munke, St. Louis, Missouri, October 15-17, 2001.

Mojave, CA, Aug 2007, 3 killed by “safe” system associated with space access vehicle. Guy Norris, Aviation Week & Space Technology, August 6, 2007

Recommendations

- Resource

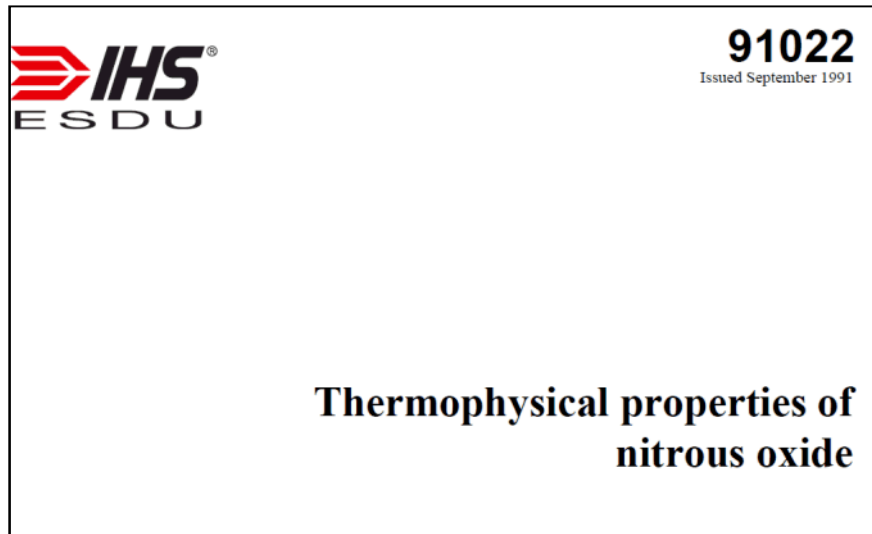

Questions

- Always remember:
 - **“Nitrous oxide is one of the safest rocket engine propellants; it can just barely kill you”. mcg**

