



CSP Program Summit 2016

DOE's National Solar Thermal Test Facility (NSTTF)

April 20, 2016

SAND # 2016???

energy.gov/sunshot

Sandia National Laboratories is a multi-program laboratory managed and operated by Sandia Corporation, a wholly owned subsidiary of Lockheed Martin Corporation, for the U.S. Department of Energy's National Nuclear Security Administration under contract DE-AC04-94AL85000.

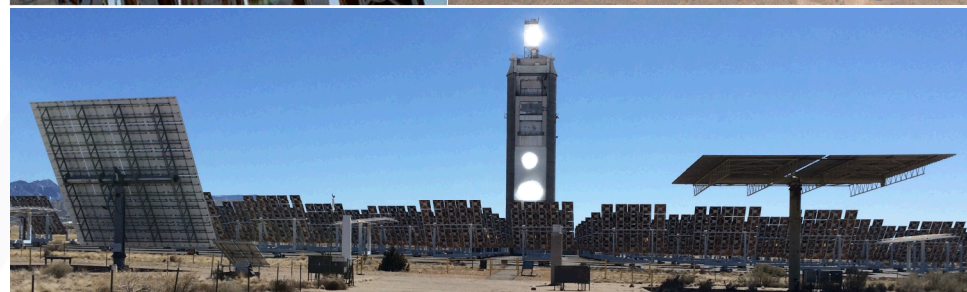

William Kolb, Subhash L. Shinde
Sandia National Laboratories
Concentrating Solar Technologies Dept.
Albuquerque, New Mexico
slshind@sandia.gov, (505) 284-2965

Sandia National Laboratories

Vision

- Develop the next-generation CSP technologies to provide dispatchable, clean solar-thermal generated electricity at higher conversion efficiencies
- Realize significant reductions in Levelized Cost of Energy (LCOE) by making fundamental advances in power cycles, receivers, thermal storage, and collectors to achieve the intent of the SunShot goals by 2020

Development Areas

- Power Tower R&D – Reduce the cost and improve the performance of high-temperature receivers and novel heliostats
- Thermal Storage R&D - Lower the cost of thermal energy storage through analysis of HTF/material compatibility and performance evaluation of next-generation hardware
- Optical Materials and Tools - Address identified cost and performance impacts in the optical systems
- System Analysis - Develop models and analysis tools that will aid in the evaluation of CSP components and systems
- Dish R&D – Develop thermal storage systems for dish-engine system that use heat pipes and latent thermal storage
- SunShine-To-Petrol (S2P) – Development of a solar chemical process to convert CO₂ and H₂O into hydrocarbon fuels

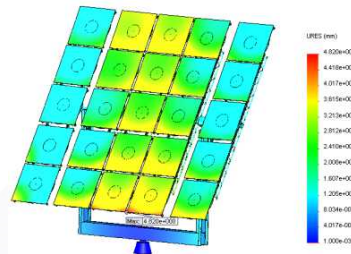

Full-scale heliostat modeling and testing at the NSTTF



Molten Salt Test Loop (MSTL)

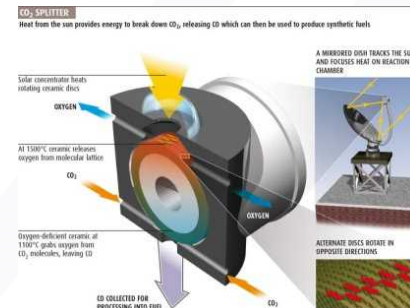

Counter-Rotating-Ring Receiver/Reactor/Recuperator (CR5)



National Solar Thermal Test Facility at Sandia National Laboratories, Albuquerque, NM



High Temp PCHE Receiver 2.2 MW

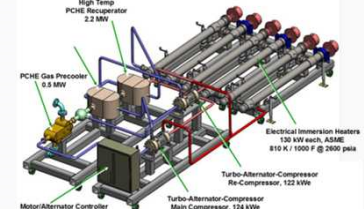

Development of supercritical CO₂ Brayton cycle

National Solar Thermal Test Facility

PV System Reliability

Dish Stirling R&D

Parabolic Trough R&D



Thermal Energy Storage R&D

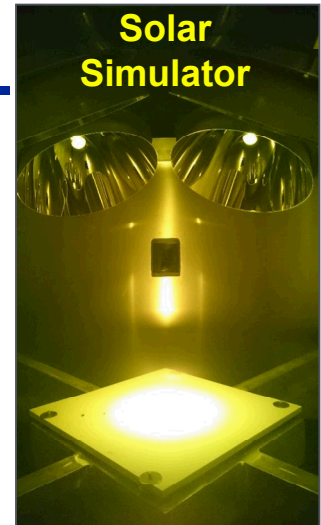

Materials R&D



Solar Fuels and Selective Absorbers

Power Tower & Heliostat Field

- **Capability**
 - Testing receivers, materials and systems under high solar flux conditions (6.2 MW_{th} incident power and 350 W/cm² peak irradiance)
- **Heliostat Field**
 - 214 heliostats.
 - 37 m²
 - Completely re-mirrored
 - Low-iron, >95% solar-weighted reflectivity
- **Tower**
 - 200 ft tall tower
 - 100-ton capacity elevating module
 - Three test bays
 - Beam Characterization Target
- **Heliostat Test Bed**
 - Full-scale heliostats
 - Novel designs
 - High performance reflective film evaluation



Shuttle Tile Testing on top of Solar Tower

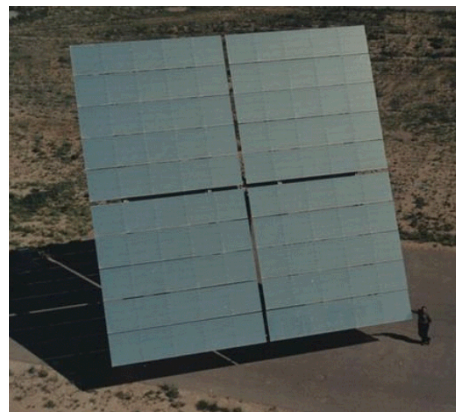
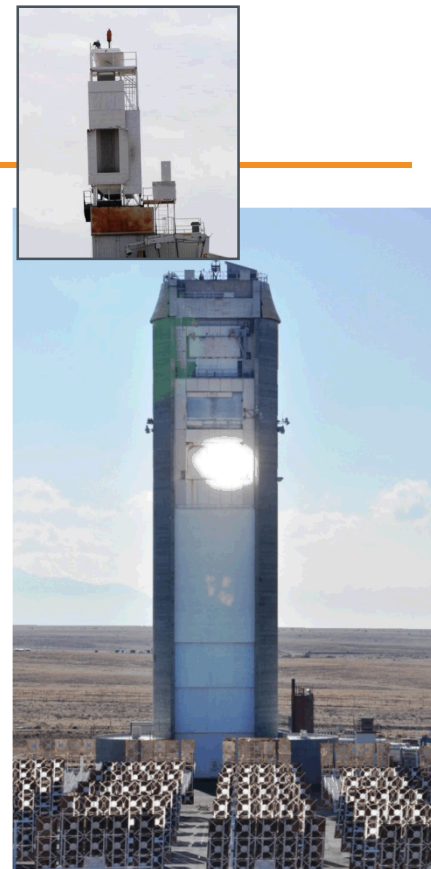
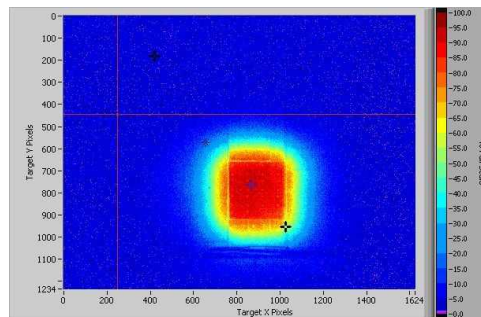

Solar Furnace

- The 16 kW solar furnace comprises:
 - Primary heliostat
 - A secondary concentrator
 - Test table where experiments or calibrations are performed.
- The peak flux provided is greater than $600\text{W}/\text{cm}^2$.
- Furnace used to demonstrate the feasibility of the Sunshine-to-Petrol initiative.
- Furnace used for selective absorber testing and material screening.
- The solar furnace is the only place in the US that can provide a solar calibration for flux gages.

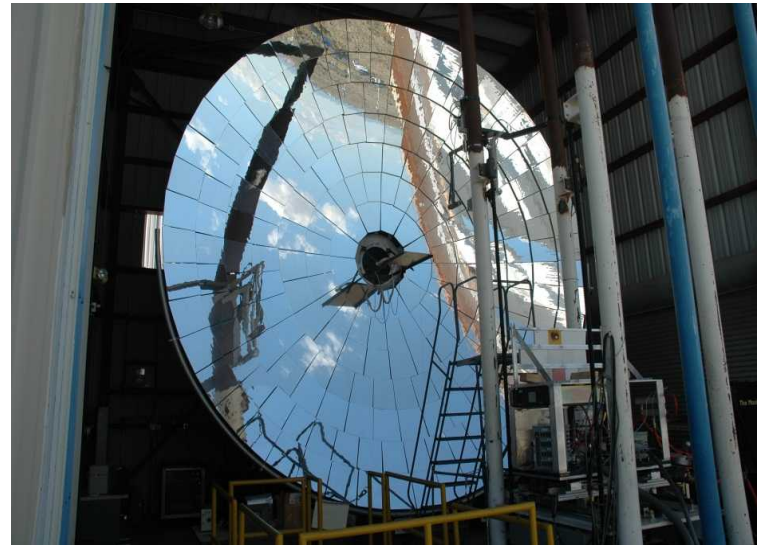

Molten Salt Test Loop

- Purpose:
 - Enables testing of molten salt hardware at high-flow and high-pressure, over a range of temperatures
- Features & Capabilities
 - 3 Test Stands
 - 60% NaNO_3 / 40% KNO_3
 - Flow rate: 1.5 m^3/min (400 gal/min)
 - Salt temperature range: 300-585°C (572-1085°F)
 - Maximum salt pressure: 40 bar (580 psi)
 - Remove up to 1.4MW solar thermal input

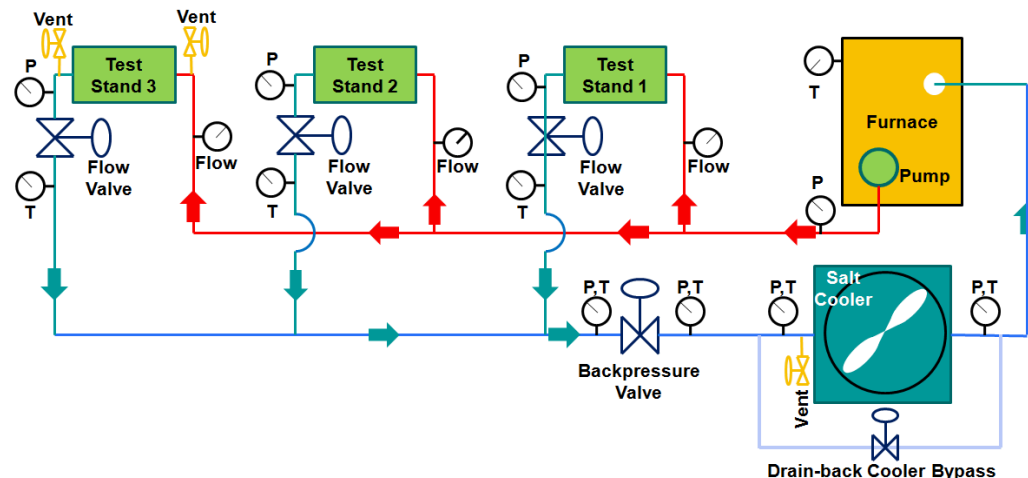

Test Capabilities: Optical Lab and Systems

- Optical characterization
 - Millimeter resolution surface normal characterization
 - Full dish or facet metrology
 - Licensable software tools
- Optical alignment
- Opto-structural interaction evaluation
- Beam characterization
- Tracking evaluation
- Soiling studies
- Reflectivity evaluation

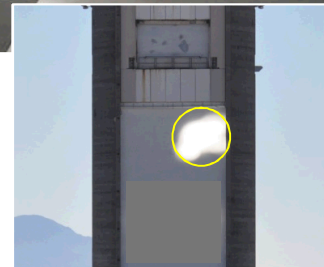
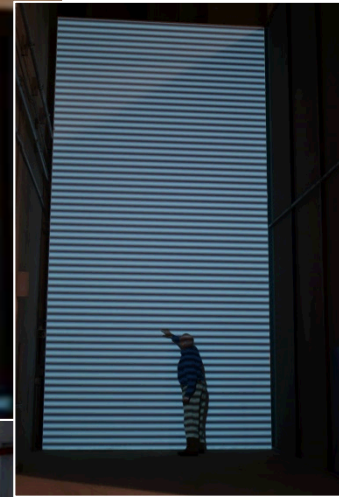
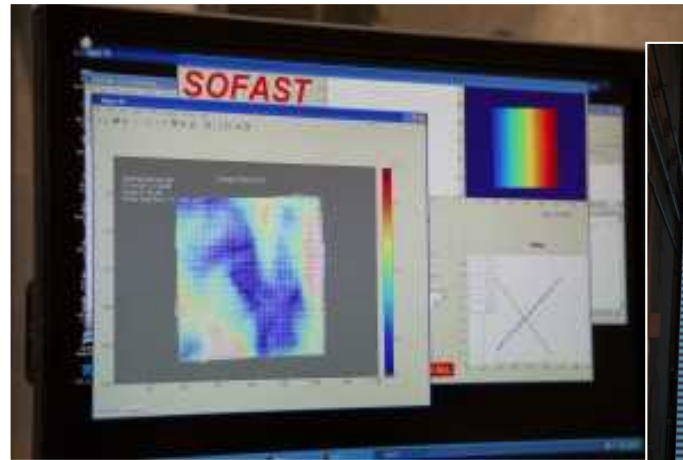

Before

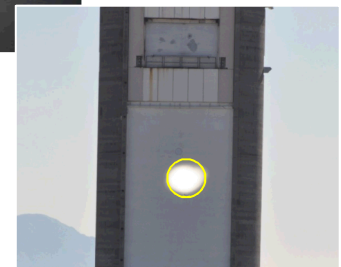

After

High-Flux Solar Simulator with Automated Sample Handling & Exposure System (ASHES)

- Purpose:
 - Solar Simulator provides accelerated aging tests for materials under high flux conditions
- Features & Capabilities
 - Peak Irradiance: 1.3 MW/m^2
 - Average Irradiance: 0.9 MW/m^2
 - Spot size: 2.54 cm
 - Operational: 24/7
 - Programmable, robotic sample holder, for multi-sample testing

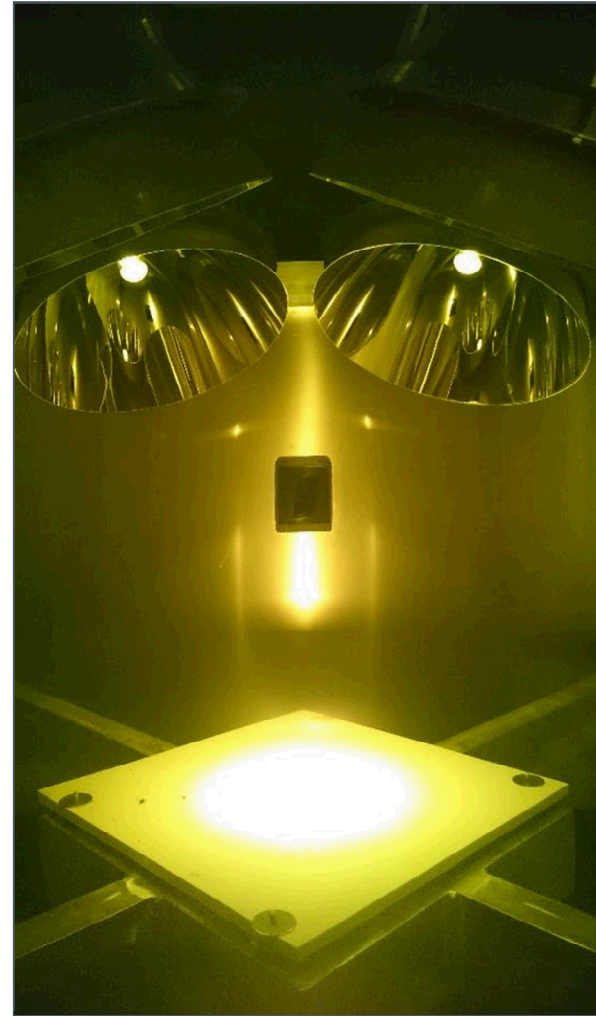

High-Flux Solar Simulator with Automated Sample Handling & Exposure System (ASHES)

- Purpose:
 - Solar Simulator provides accelerated aging tests for materials under high flux
- Features & Capabilities
- Peak Irradiance: 1.3 MW/m^2
- Average Irradiance: 0.9 MW/m^2
- Spot size: 2.54 cm
- Operational: 24/7
- Programmable, robotic sample holder, for multi-sample testing

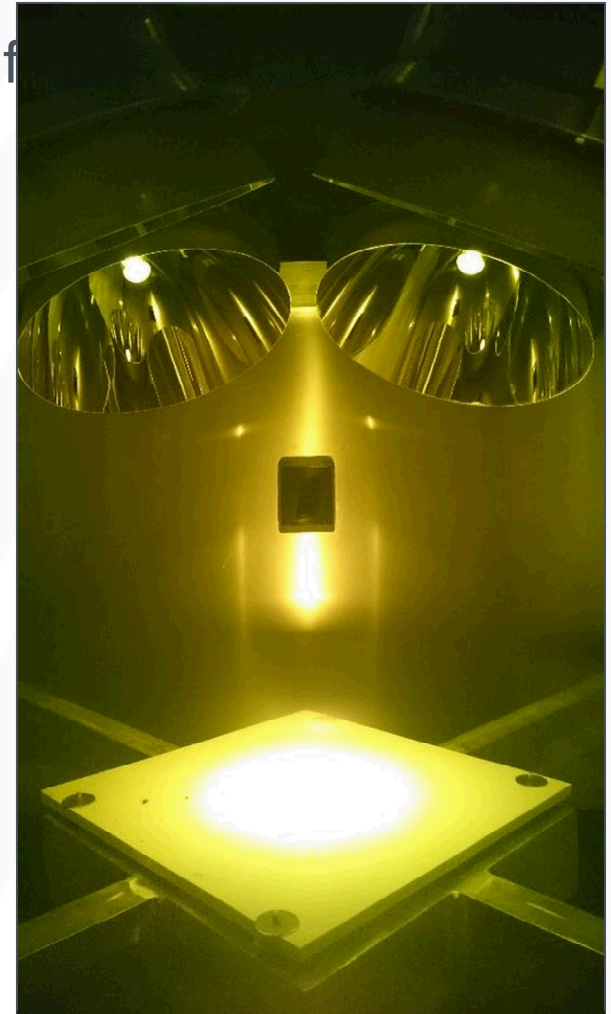

Sandia's Current CSP Related R&D

- Next Gen Receivers
- Dish Storage
- Thermochemical Energy Storage
- Solar Selective Materials
- Novel Reflectors
- Solar Hydrogen

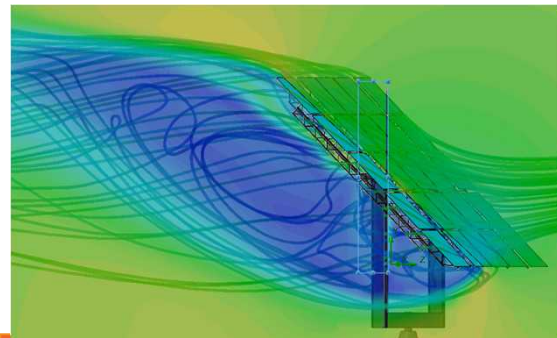
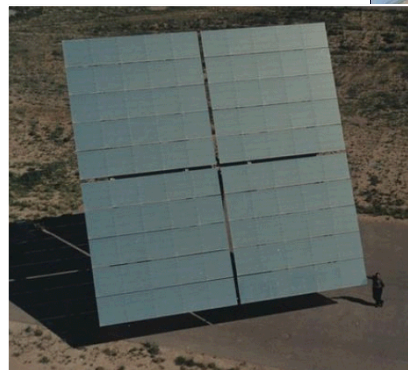

Falling Particle Receiver

- Falling Particle Receivers
 - Benefits
 - High temperatures ($T > 700\text{ }^{\circ}\text{C}$)
 - Direct energy storage of particles
 - Increased fluxes
 - Challenges
 - Particle attrition / wear / conveyance
 - Particle solar absorption
 - Particle/fluid heat exchange
 - Need to increase thermal efficiency (from 50% to 90%)



High-Temperature Solar Selective Coatings

Selective absorber coatings for receivers with high absorptance in the solar spectrum & lower emittance in the infrared, stable in air, easily applied at large scale, cost effective, and survives thousands of heating and cooling cycles

Transition Metal oxides

- Inherently stable at high temperature and in air
- Amenable to doping and substitution to chemically tailor their properties
- Ease of application (thermal spray, paint, dip-coat...)

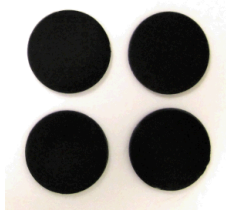
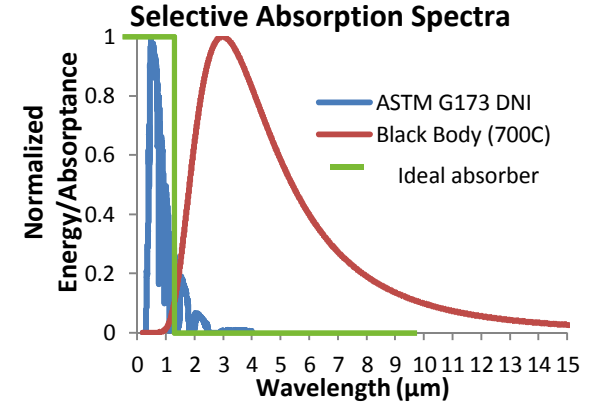

Thermal-sprayed oxide coating, aged 240 h

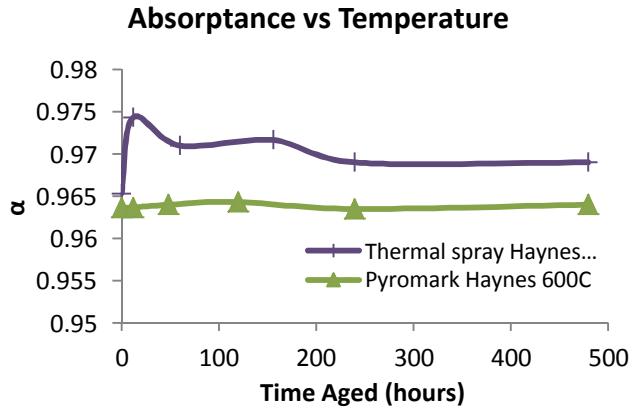

Thermal-sprayed oxide maintains > 96% absorptivity after 480 h at 600 °C (isothermal)

Solar furnace: 150 automatic heating/cooling cycles on already-aged samples

600 kW m⁻² / 0 kW m⁻²
850 °C / 100 °C
substrate: Inconel 625

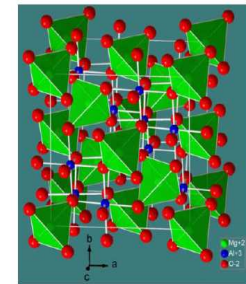
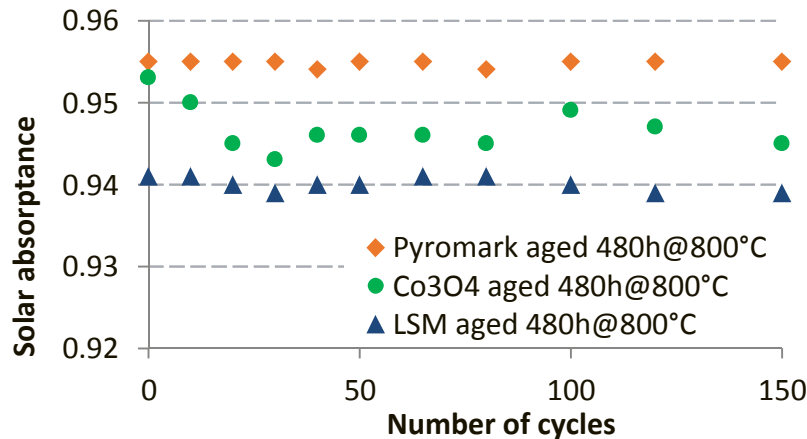

High Performance Reduction/Oxidation Metal Oxides for Thermochemical Energy Storage (PROMOTES)

The PROMOTES effort seeks to advance both materials and systems for TCES through the development and demonstration of an innovative storage approach for solarized Air-Brayton power cycles.

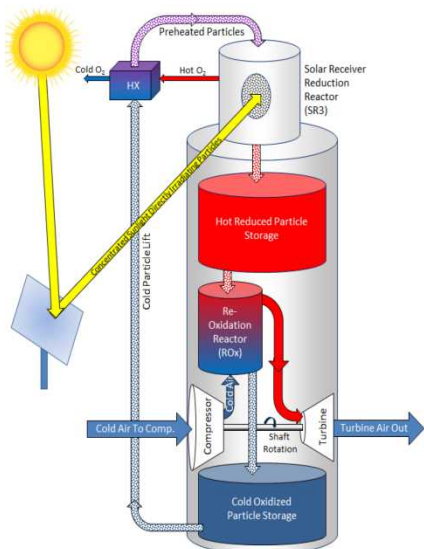

- Challenge: Current heat storage methods are limited for next-generation CSP towers, which are expected to operate at temperatures $> 600\text{ }^{\circ}\text{C}$, in order to maximize efficiency and economic competitiveness
- Solution: Thermochemical energy storage (TCES)
 - Heat stored as chemical bonds can be stored indefinitely and accessed on-demand
 - Sensible and latent heat recovery results in high storage densities
 - Direct irradiation of thermal storage media

- Result: Newly developed redox-active $\text{CaMnO}_{3-\delta}$ -based materials display total mass specific enthalpies of $> 1200\text{ kJ/kg}$ ($T_H = 1200\text{ }^{\circ}\text{C}$, $T_L = 200\text{ }^{\circ}\text{C}$)

$$\Delta H_{\text{tot}} = \Delta H_{\text{rxn}} + C_p \Delta T$$

| Material | Max δ | ΔH_{rxn} (kJ/kg) (at δ_{max}) | Est'd C_p (kJ/kg-K) | ΔH_{tot} (kJ/kg) |
|---|--------------|---|-----------------------|---------------------------------|
| $\text{CaTi}_{0.2}\text{Mn}_{0.8}\text{O}_{3-\delta}$ | 0.293 | 393 | 0.881 | 1243 |
| $\text{CaAl}_{0.2}\text{Mn}_{0.8}\text{O}_{3-\delta}$ | 0.322 | 371 | 0.918 | 1269 |

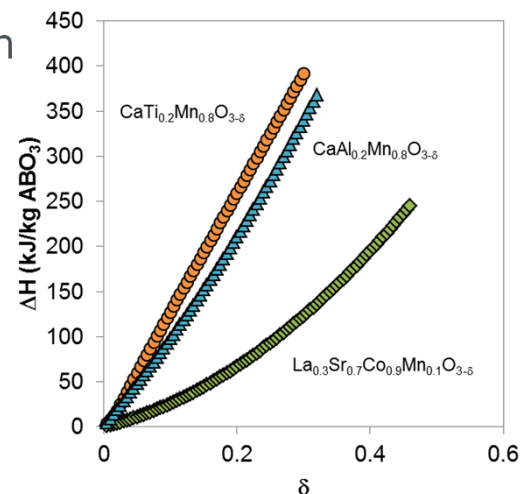

KEY PARTNERS: Georgia Institute of Technology, King Saud University, Arizona State University

Dielectric Metasurface Concentrators

Problem Statement

- The largest expense (~50%) in CSP installation cost is the collector field, which includes the mirror and tracking costs
- Reducing the tracking requirement can alleviate collector field cost

Hypothesis

- Metasurfaces can be engineered to focus sunlight over a broad acceptance angle and broad spectrum, thus minimizing the tracking requirements
- With large acceptance angle, diffuse light can be collected for improved efficiencies

Scientific Approach

- Tune the metasurfaces for broad acceptance angle and reflection of broad spectrum
- Use Sandia's nano-fab capabilities

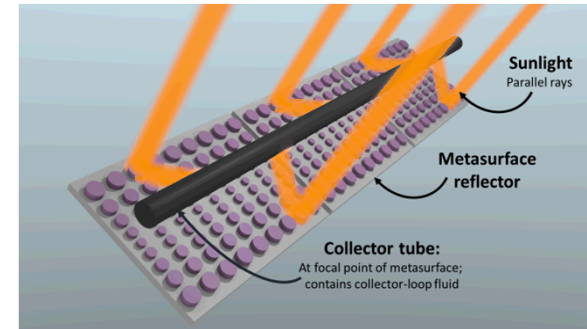

Minimized Tracking

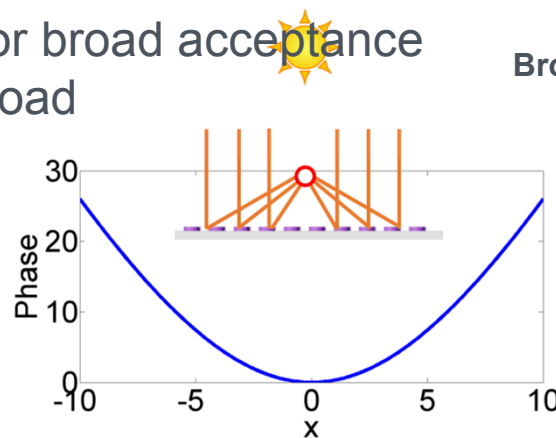
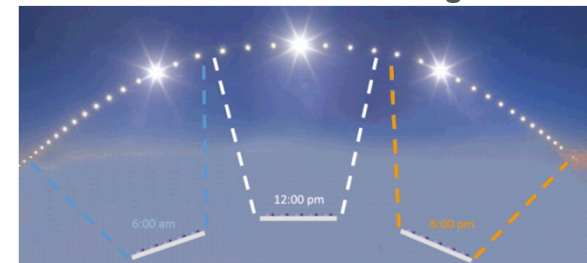

Broad Acceptance Angle

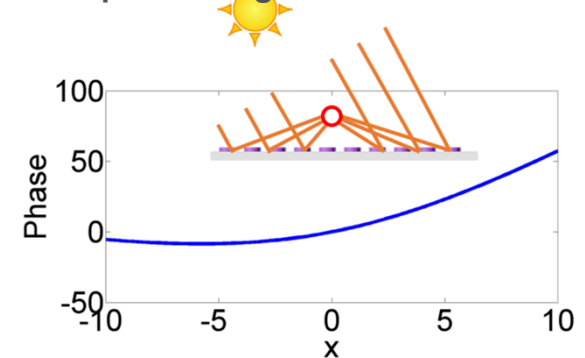

Single-Axis Tracking Waveguide Collector

Problem Statement

- The largest expense (~50%) in CSP installation cost is the collector field, which includes the mirror and tracking costs
- Relaxing the tracking requirement and using low-cost materials can alleviate collector field cost

Hypothesis

- Sunlight can be efficiently collected and prorogated within the waveguide panel using total internal reflection to one edge of the panel where the thermal energy will be collected

Scientific Approach

- Waveguide collected will be designed to have broad acceptance angle to relax the tracking requirements
- Manufacturing will be optimized for low-cost assembly of the waveguide panels

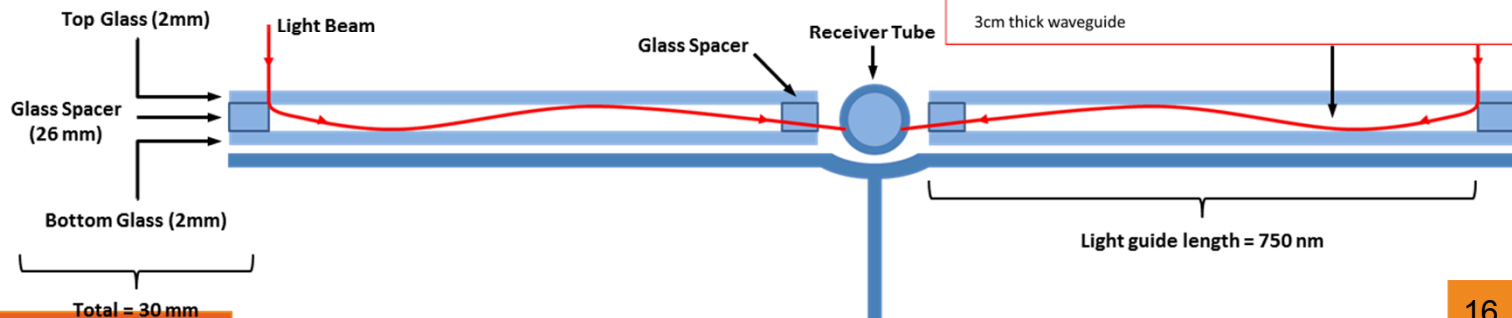
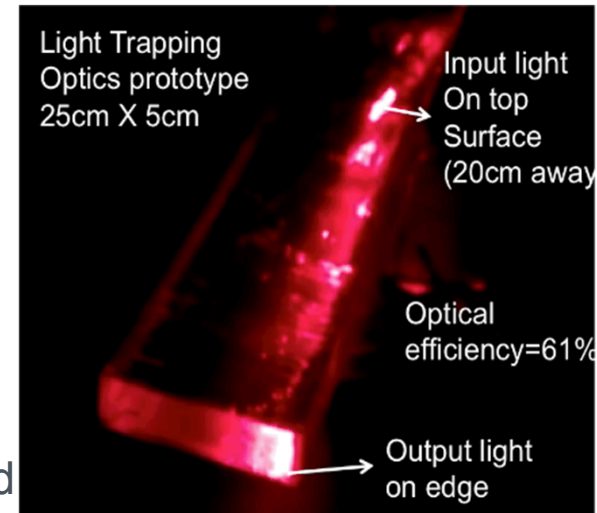

High Efficiency Solar Thermochemical Reactor for Hydrogen Production (STCH)

The STCH effort seeks to advance concentrated solar thermochemical hydrogen production technology through materials and engineering innovation.

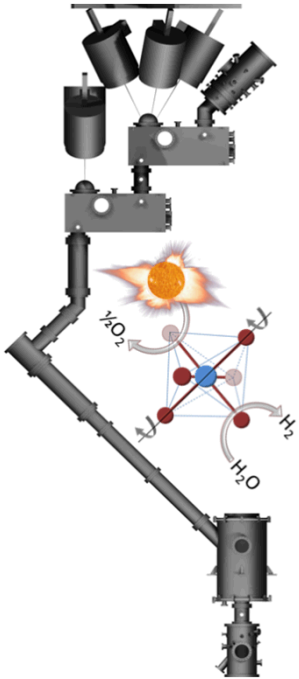

- Challenge: Demonstrate that a high temperature, two-step thermochemical cycle to split water using concentrated solar energy can meet DOE targets for H₂ production cost and process efficiency
- Solution: Innovative reactor design coupled to novel redox materials
 - Achieve unprecedented solar-to-H₂ conversion efficiency using our particle-based cascading pressure receiver/reactor (CPR2)
 - Formulate high redox capacity, low cost active materials that meet H₂ production cost targets

- Result: Designed a 3kW CPR2 prototype that when fabricated will demonstrate Sandia's *novel* and *scalable* reactor concept
- Result: Developed SrLaMnAlO_{3-δ}-based materials that have a fuel capacity one order of magnitude > CeO₂ (T_H = 1350 °C, T_L = 1000 °C)

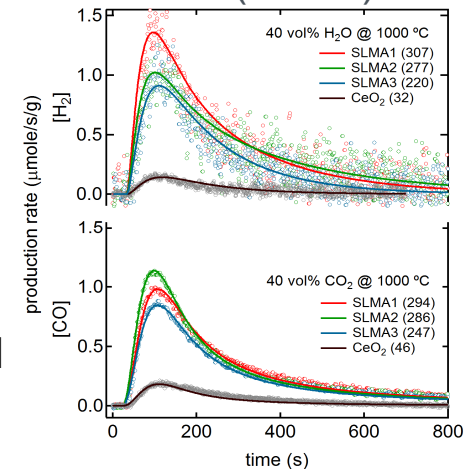

KEY PARTNERS: German Aerospace Center, Arizona State Univ., Bucknell Univ., Colorado School of Mines, Stanford

Supercritical CO₂ Brayton Cycle

- High efficiency
 - 50% thermal-to-electric
- Compact power conversion
 - Liquid-like densities with CO₂

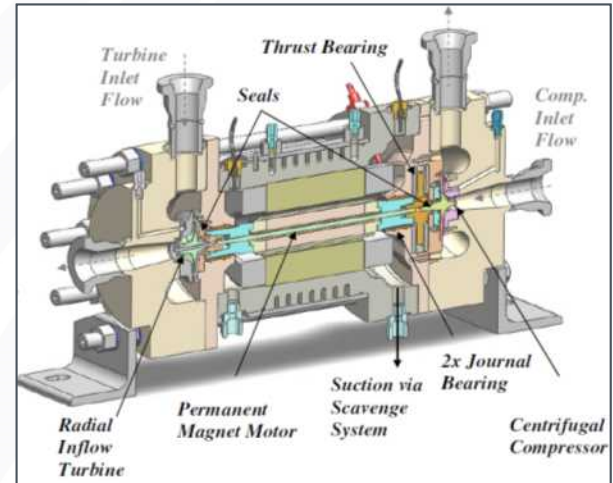

Sandia sCO₂ turbo-alternator-compressor (Conboy et al., 2013)

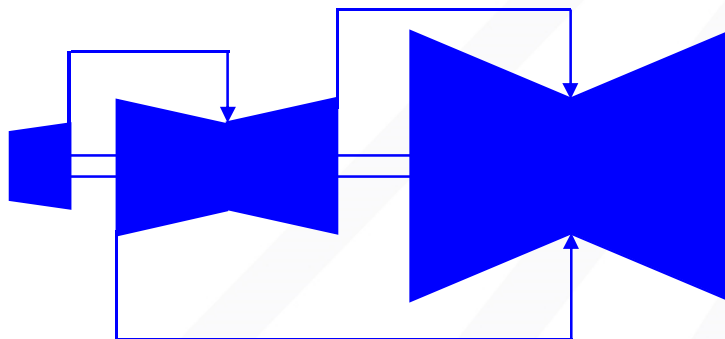

Steam Turbine (250 MWe)



He Turbine
(300 MWe)

1 m
▲

S-CO₂
(300 MWe)

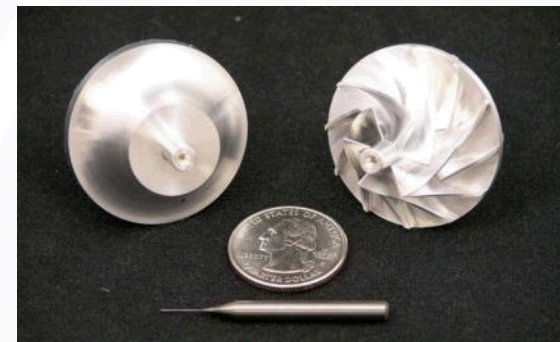

Compressor wheel for 150 kW_e sCO₂ Brayton cycle (SAND2010-0172)

Thank You
