

Solar-Thermochemical Hydrogen Research

Hydrogen From Water and Solar Heat in a "Hydrogen Kiln," SAND2015-7522PE

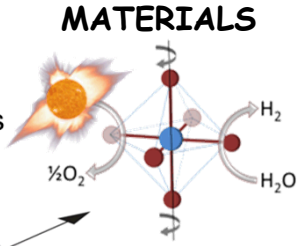

- CPR2: From Concept to Device

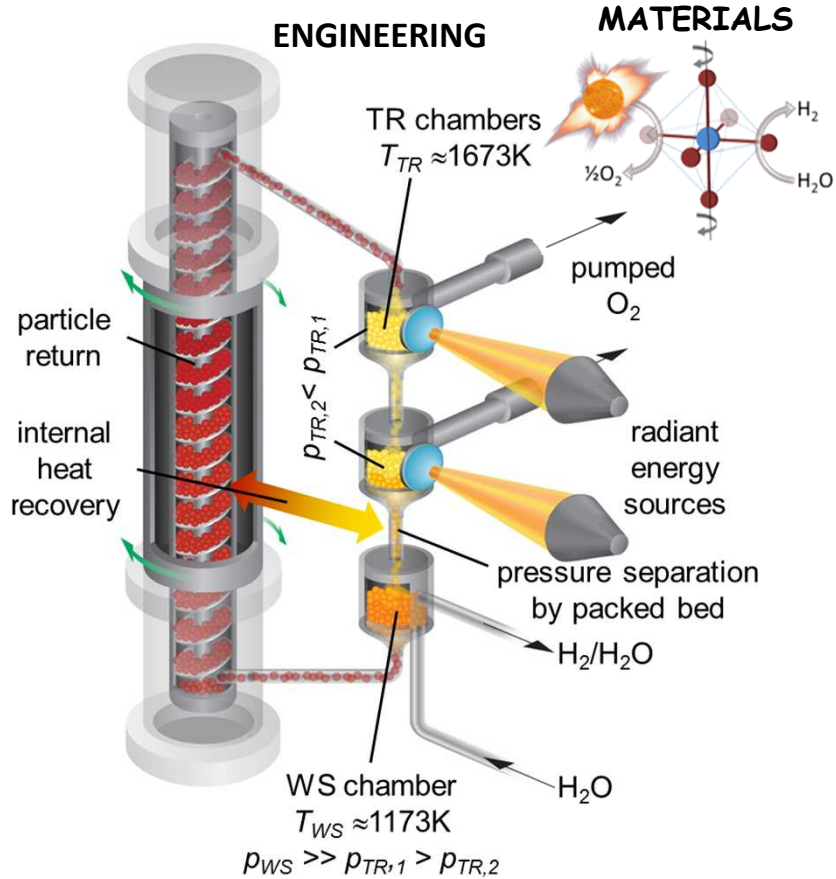
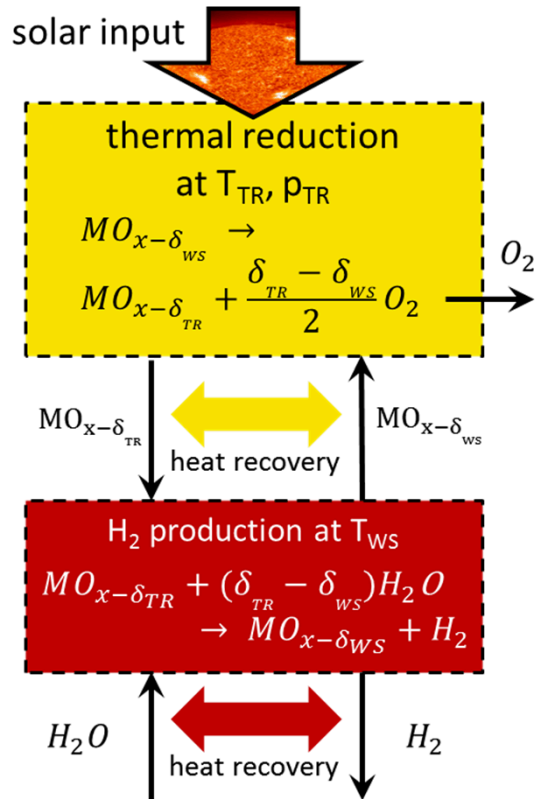

- Compatible with tower system

Process simplicity:

- Two-step heat engine

- Cascading pressure reactor: CPR2
- Advanced redox materials

Efficiency and economics via reactor and material design

A Wide Collaboration

- Sandia National Laboratories (Anthony McDaniel, Ivan Ermanoski, Jim Miller, Andrea Ambrosini)
 - Reactor modeling, design and construction; material characterization
- German Aerospace Center (DLR) (Christian Sattler, Martin Roeb)
 - Receiver design, technoeconomic analysis
- Bucknell University (Nathan Siegel)
 - Receiver and simulator design, technoeconomics
- Arizona State University (Ellen Stechel, Nathan Johnson)
 - Technoeconomic modeling
- Colorado School of Mines (Ryan O’Hayre, Jianhua Tong)
 - Material development and characterization
- Northwestern University (Chris Wolverton)
 - Material development (DFT)
- Stanford University (William Chueh)
 - Material development

Reactor Modeling for High Efficiency Operation

$$\eta = \left(\frac{P_{TH}}{P_S} \right) \left(\frac{LHV_{H_2}}{Q} \right) = \frac{\dot{n}_{H_2} LHV_{H_2}}{P_S} \rightarrow \dot{n}_{H_2} = \frac{P_{TH}}{Q}$$

$$P_{TH} = r_{12} * r_d * t_W * A * P_S - P_{rad}$$

$$Q = Q_{TR} + Q_{SH} + Q_{AUX}$$

Overall challenges:

- High temperature
- Low reduction pressure
- Material redox chemistry

Key reactor design and operation principles:

- Direct solar absorption
- Continuous on-sun operation
- Internal heat recovery and reuse
- Temperature and product separation
- High-vacuum thermal reduction
- Optimal reaction temperatures

Technological requirements:

- Scalability - MW
- Reactor and material durability
- Wide operational flexibility

p_{TR} – thermal reduction pressure
 ϵ_S – solid heat recovery effectiveness
 ϵ_G – gas heat recovery effectiveness

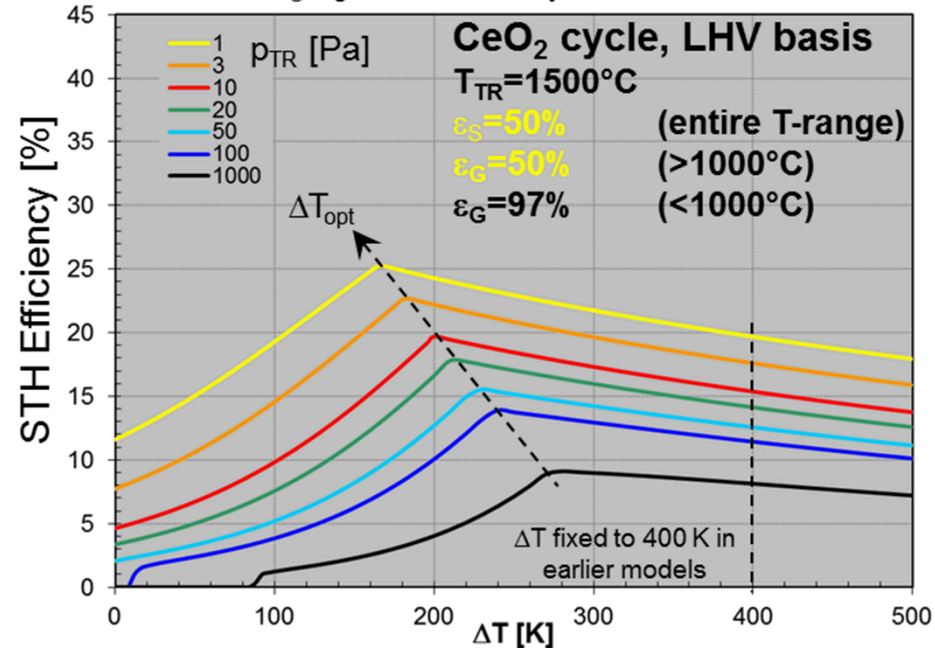

I. Ermanoski, *International Journal of Hydrogen Energy* **39**, 13114 (2014), doi:10.1016/j.ijhydene.2014.06.143.

I. Ermanoski, J. E. Miller, M. D. Allendorf, *Physical Chemistry Chemical Physics*. **16**, 8418 (2014).

N. P. Siegel, J. E. Miller, I. Ermanoski, R. B. Diver, E. B. Stechel, *Ind. Eng. Chem. Res.* **52**, 3276–3286 (2013).

I. Ermanoski, N. P. Siegel, E. B. Stechel, *J. Solar Energy Engineering*. **135**, 031002 (2013).

Sandia Solar Reactors: A Decade of Innovation

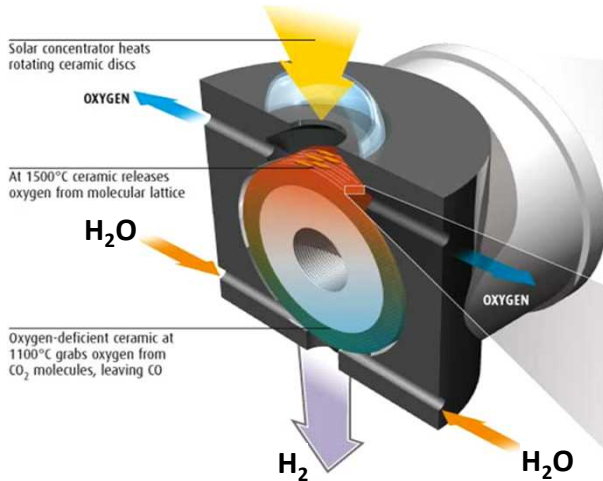

Counter-Rotating-Ring Receiver Reactor Recuperator (CR5): 2004-2012
 R. B. Diver et al., *J. Solar Energy Engineering* (2008) 130

- Direct solar absorption
- Internal heat recovery between T_{TR} and T_{WS}
- Continuous on-sun operation
- Temperature and product separation

Limitations:

- Reactive structures durability
- Reactor operation and material kinetics strongly coupled
- Thermal reduction $p_{TR} \sim 1-10\text{kPa}$

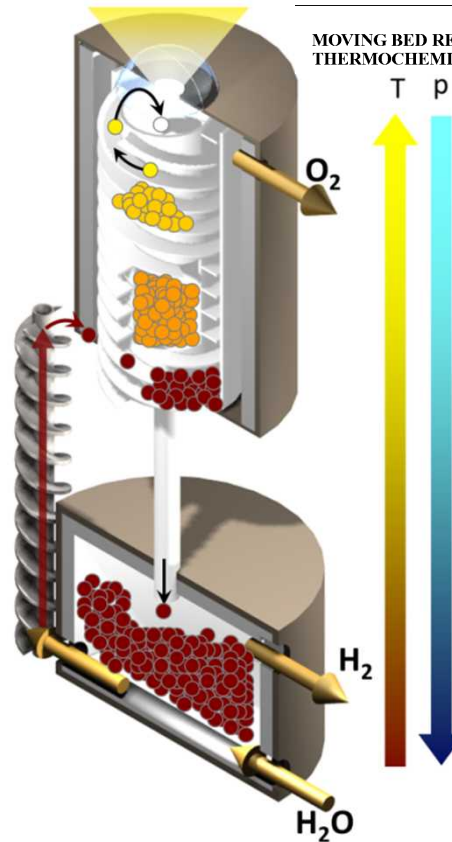

United States Patent
 Ermanoski

(10) Patent No.: US 8,420,032 B1
 (45) Date of Patent: Apr. 16, 2013

Moving Particle Bed Reactor: 2009-2014

I. Ermanoski et. al, *J. Solar Energy Engineering* (2013) 135

Key improvements:

- Pressure separation (thermal reduction step vacuum pumping)
- Non-monolithic oxide
- Reaction kinetics decoupled from reactor operation

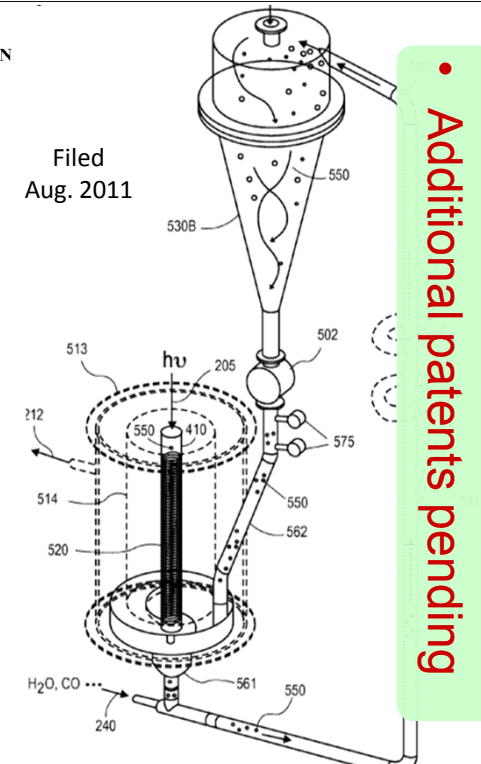

Filed Aug. 2011

• Additional patents pending

Limitations:

- $p_{TR} \sim 10-100\text{Pa}$
- Solid-solid heat recovery requirements

Cascading Pressure Reactor: A Design for Ultra-Low Thermal Reduction Pressure

Key improvements:

- Thermal reduction pressure (0.1-10Pa)
- Decreased solid-solid heat recovery requirement
- Decreased pump work requirement
- Compatibility with MW-scale plant

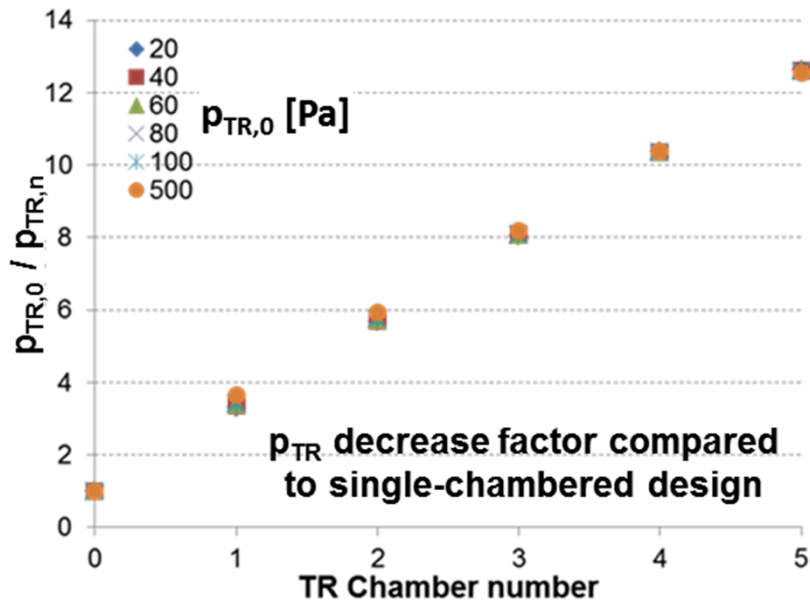

• 10x pressure decrease over earlier design

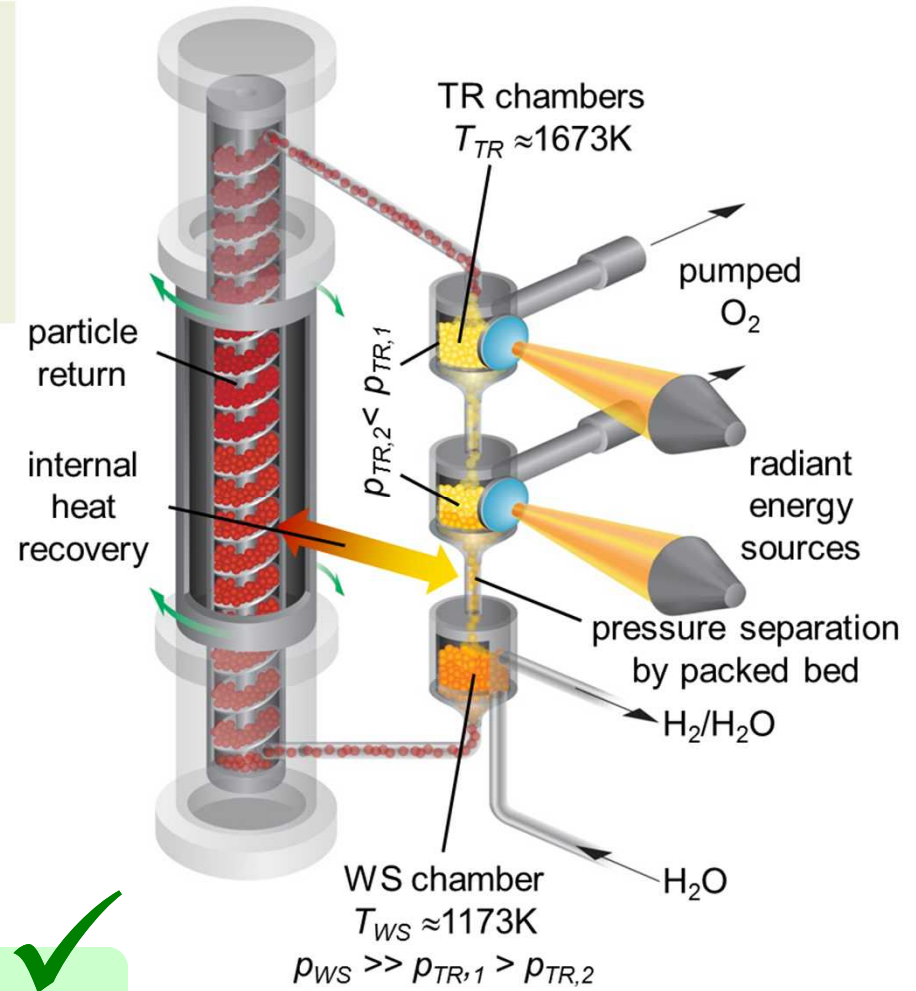

Cascading Pressure Reactor: 2013-onward
I. Ermanoski, *Int. J. of Hydrogen Energy* (2014) 39

Introduced Perovskites to Solar Fuel R&D

Energy &
Environmental Science

RSC Publishing

COMMUNICATION

View Article Online
View Journal

Sr- and Mn-doped $\text{LaAlO}_{3-\delta}$ for solar thermochemical H_2 and CO production†

Anthony H. McDaniel,^{*a} Elizabeth C. Miller,^{‡ab} Darwin Arifin,^{Sa} Andrea Ambrosini,^b Eric N. Coker,^b Ryan O'Hayre,^c William C. Chueh^{¶a} and Jianhua Tong^{*c}

Cite this: DOI: 10.1039/c3ee41372a

Received 22nd April 2013
Accepted 4th June 2013

DOI: 10.1039/c3ee41372a

www.rsc.org/ees

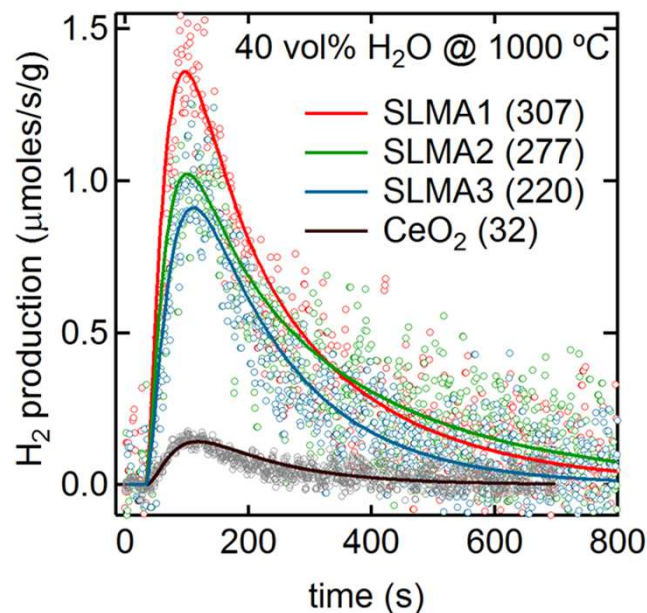
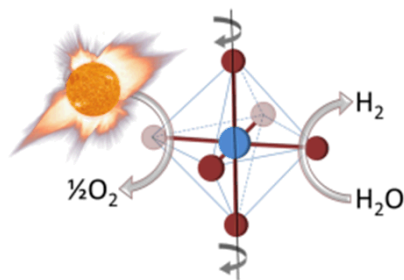

- Perovskite compounds split H_2O in a thermochemical cycle.
 - First of a kind observation, also demonstrated durability
- Kinetics benchmarked against CeO_2 .
 - Similarly fast oxidation rates
- Make $\sim 9\times$ more H_2 than CeO_2 at $T_{\text{TR}} = 1350\text{ }^\circ\text{C}$.

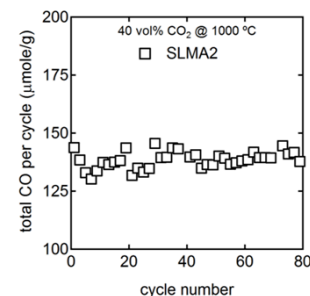

Engineering Material Thermochemistry

Why is it important?

- **Determines operating conditions.**

- Heat flux, T_{TR} , T_{WS}
- Mass fluxes: MO_x , steam, H_2

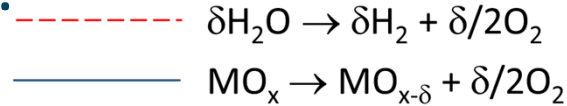

- **Determines cost of H_2 .**

- Plant design and operation
- η_c is one component of STH efficiency

How is it done?

- **Identify candidate oxides.**
- **Manipulate crystal structure.**
 - A & B site doping
 - A & B site substitution
 - Introduce new phases

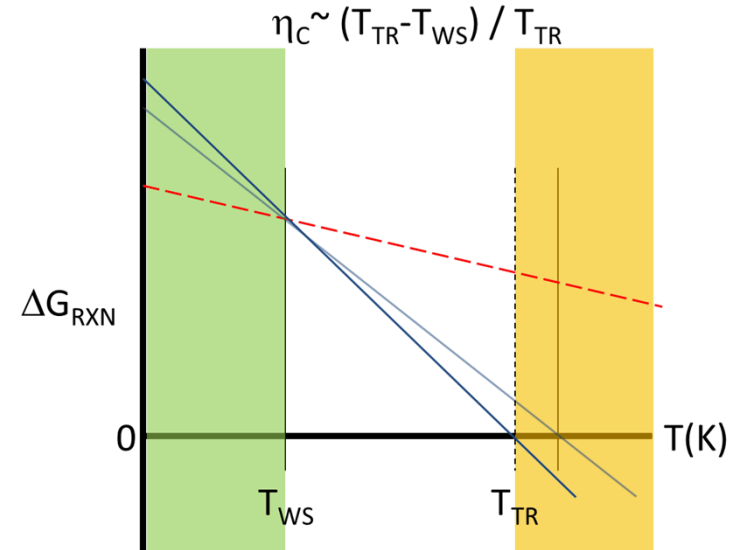

- **Reduce T_{TR} and optimize STH efficiency.**

Detailed Hydrogen Plant Models

