

Advanced Lean-Burn DI Spark Ignition Fuels Research

Magnus Sjöberg

Sandia National Laboratories



June 11th, 2015

Project ID: FT006

Acknowledgement

The work was performed at the Combustion Research Facility, Sandia National Laboratories, Livermore, CA. Financial support was provided by the U.S. Department of Energy, Office of Vehicle Technologies. Sandia National Laboratories is a multi-program laboratory managed and operated by Sandia Corporation, a wholly owned subsidiary of Lockheed Martin Corporation, for the U.S. Department of Energy's National Nuclear Security Administration under contract DE-AC04-94AL85000.

This presentation does not contain any proprietary, confidential, or otherwise restricted information



Overview

Timeline

- Project provides science to support industry to develop advanced lean/dilute-burn SI engines that utilize non-petroleum fuels.
- Project directions and continuation are reviewed annually.

Barriers

- Inadequate data and predictive tools for fuel property effects on combustion and engine efficiency optimization.
- Evaluate new fuels and fuel blends for efficiency, emissions, and operating stability with advanced SI combustion.
 1. Lean, unthrottled DISI with spray-guided combustion.
 2. Well-mixed dilute or lean with advanced ignition.

Budget

- Project funded by DOE/VT via Kevin Stork.
- FY14 - \$700 k
- FY15 - \$705 k

Partners / Collaborators

- PI: Sandia (M. Sjöberg).
- 15 Industry partners in the Advanced Engine Combustion MOU.
- General Motors - Hardware.
- D.L. Reuss (formerly at GM).
- Toyota – Funds-in knock project (not VT).
- W. Zeng (post-doc).
- Z. Hu (long-term visitor from Tongji Univ.)
- C. Tornatore – visiting Fulbright scholar from Istituto Motori, Italy.
- Transient Plasma Systems Inc.
- LLNL (W. Pitz *et al.*) – Flame-Speed Calculations and CFD Modeling.



Objectives - Relevance

Project goals are to provide the science-base needed for:

- Determining fuel characteristics that enable current and emerging advanced combustion engines that are as efficient as possible.

1. DISI with spray-guided stratified charge combustion system

- Has demonstrated strong potential for throttle-less operation for high efficiency.
- These combustion processes can be strongly affected by fuel properties.

2. DISI with well-mixed lean/dilute combustion system

- Also strong potential for improved efficiency.
- High combustion stability and combustion efficiency are keys to success.

- 1. Develop a broad understanding of spray-guided SI combustion (*i.e.* conceptual models, including fuel effects).
- 2. Identify and explain combinations of fuel characteristics and ignition strategies that enable stable and efficient well-mixed dilute operation.

- Current focus is on E30 and gasoline, but also higher blend ratios.
 - Flex-fuel vehicles need to function with 0 – 85% ethanol in the fuel tank.
- Watch for emerging bio-components, coordinate with Optima projects.

Approach

- Combine metal- and optical-engine experiments and modeling to develop a broad understanding of the impact of fuel properties on DISI combustion processes.
- First, conduct performance testing with all-metal engine over wide ranges of conditions to identify critical combinations of operating conditions and fuels.
 - Speed, load, intake pressure, EGR, and stratification level.
 - Investigate and apply advanced ignition when it improves impact of the fuels research.
- Second, apply a combination of optical and conventional diagnostics to develop the understanding needed to mitigate barriers.
 - Include full spectrum of phenomena; from intake flows, fuel injection, fuel-air mixing, spark development and ignition, to flame deflagration and end-gas autoignition.

Supporting modeling through collaborations:

- Chemical-kinetics modeling of flame-speed and autoignition reactivity.
- CFD modeling of flow-spray interactions and end-gas autoignition.

- Addresses barriers to high efficiency, robustness, and low emissions by increasing scientific knowledge base and enhancing the development of predictive tools.



Approach – Engine / Diagnostics

Drop-down single-cylinder engine. Bore = 86.0 mm, Stroke = 95.1 mm, 0.55 liter.

- Piston bowl and closely located spark and injector.
⇒ Highly relevant for stratified operation. 8-hole injector with 60° included angle.
- Identical geometry for all-metal and optical configurations
⇒ Minimal discrepancy between performance/emissions testing and optical tests.
- Apply advanced ignition when it increases relevance of the fuels research.
- Apply a range of high-speed optical diagnostics:
PIV - Flows. Mie – Liquid Spray. IR - Fuel Vapor. Plasma & flame imaging.
- Flame spectroscopy.

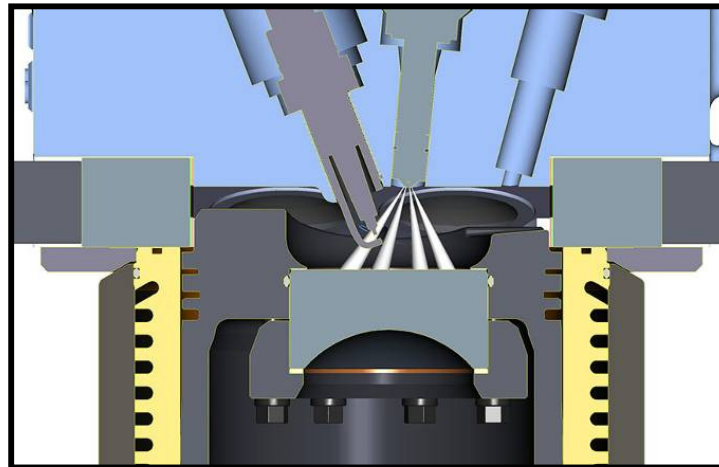
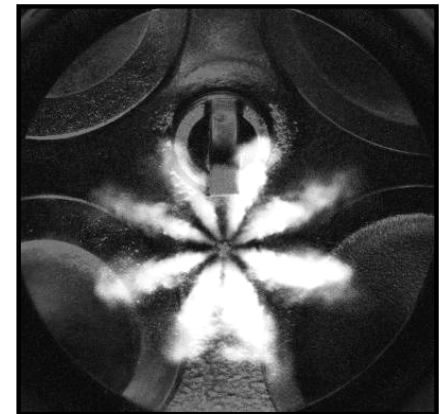
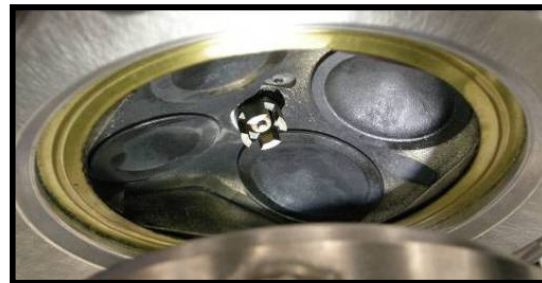
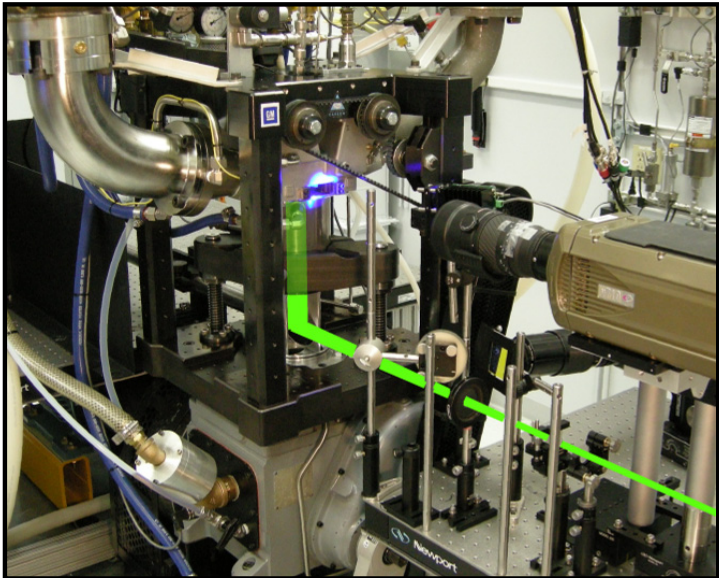

Milestones – FY2014 & 2015



- ✓ • **December 2013**
Determine the role of ethanol/gasoline mixture proportions on soot emissions across load ranges for stratified operation.
- ✓ • **March 2014**
Quantify statistically the relationship between the in-cylinder flow field, spark-plasma development, and combustion variability.
- ✓ • **June 2014**
Determine the role of the intake flow for both well-mixed and highly stratified operation.
- ✓ • **September 2014**
Quantify the role of ethanol/gasoline mixture proportions on stability of stratified ignition for wide ranges of spark timings.
- ✓ • **December 2014**
Present at AEC meeting flame imaging and PIV measurements that demonstrate the combined effects of intake- and spray-induced flows on flame-spread stability of stratified-charge operation.
- ✓ • **March 2015**
Demonstrate the influence of ethanol in the E0 - E30 range on lean stability limits and fuel-economy improvements for lean well-mixed operation.
- ✓ • **June 2015**
Compare the thermal efficiency of unthrottled operation with partial-fuel stratification to that of traditional throttled well-mixed stoichiometric operation, using E85 and gasoline.
- **September 2015**
Write a conference paper that documents the effects of fuel type on lean limits of well-mixed operation.
- **September 2015 – Stretch**
Develop a conceptual description of the effects of ethanol/gasoline mixture proportions on the heat-release rate and combustion stability for stratified charge operation.

SAE Congress
paper planned



Technical Accomplishments

1. DISI with spray-guided stratified charge combustion system

- ➔ ● Based on PIV and flame imaging, developed a conceptual model of the spray-swirl interactions that act to stabilize both flow field and stratified combustion.
- Continued examination of effects of fuel blend (E0 to E30) on stratified operation.
- ➔ — Boosted operation with double injections.
- Performed initial mapping of ignition limits with regular spark system, and role of autoignition for highly boosted stratified-charge operation.

2. DISI with well-mixed lean or dilute combustion system

- ➔ ● Examined ways to enhance control authority of the ignition process.
 - Performed initial examination of electrode-geometry effects for 10-pulse ignition.
 - Applied partial fuel stratification (PFS) as a powerful chemical igniter.
 - Quantified control authority and compared with regular spark system.
- ➔ ● Compared lean stability limits and fuel-efficiency gain for E30, E85 and gasoline.
- ➔ — Used enhanced ignition to ensure repeatable end-gas autoignition for high combustion efficiency of ultra-lean deflagration-based SI operation.
- ➔ — Contrasted lean and dilute operation, using flame models to explain effect of $[O_2]$.

Diagnostics Development.

- ➔ ● Initial use of flame spectroscopy to measure fuel stratification for E30 and gasoline.
- Demonstrated IR-detection of vapor penetration of E85 and gasoline fuel sprays.

Conceptual Model of Swirl/Spray Interactions for Stratified Charge Oper.

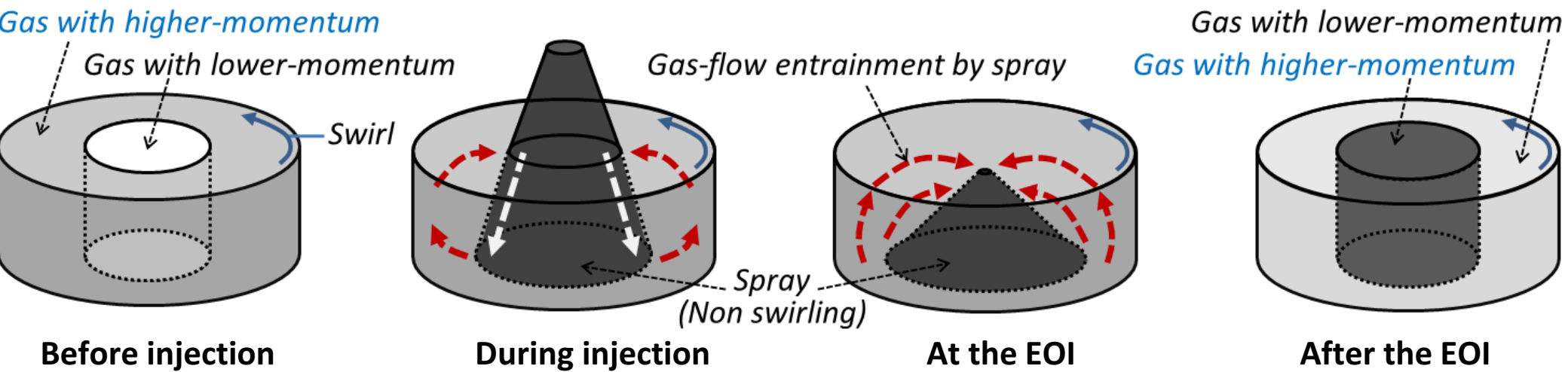
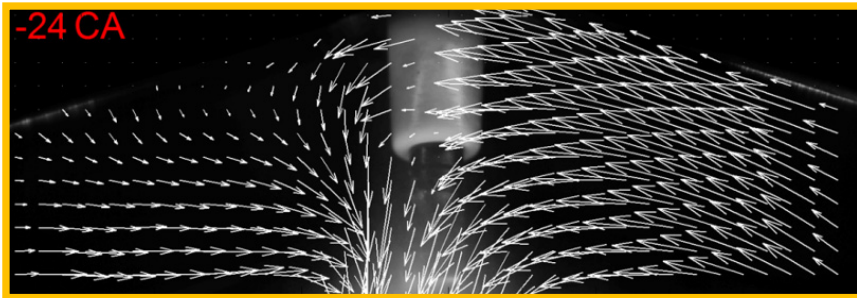
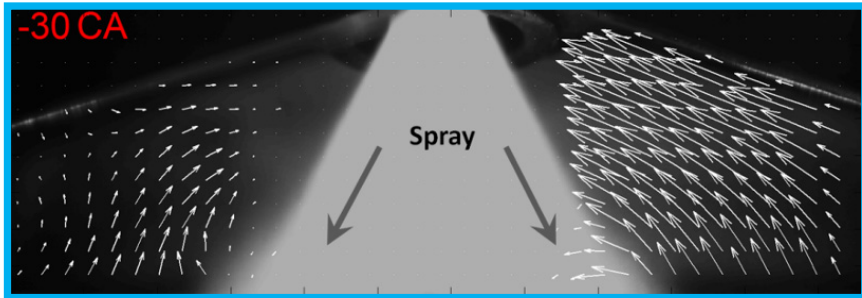
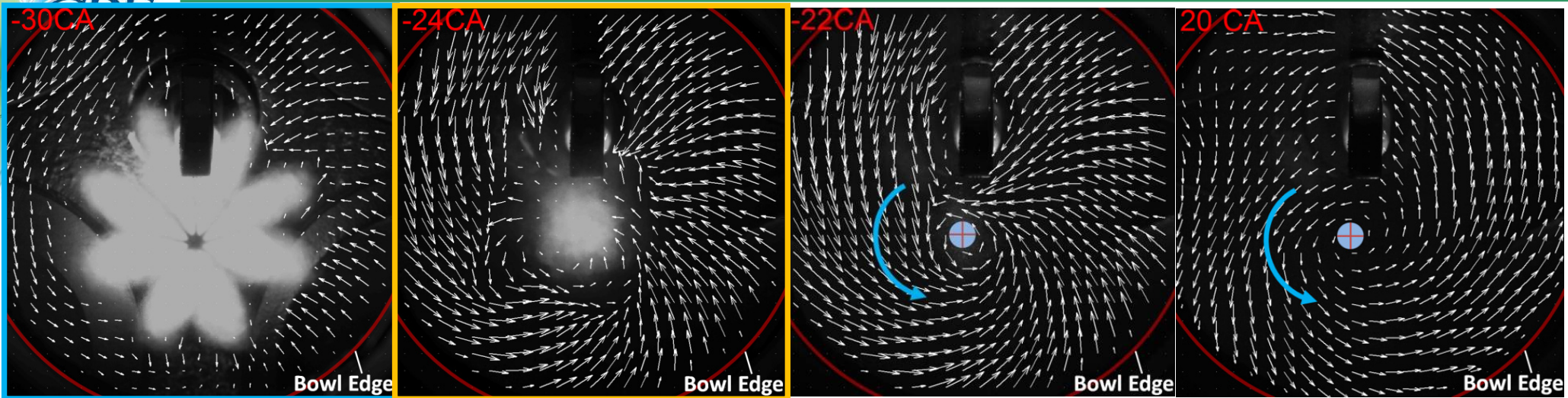

- PIV shows that repeatable flow is required for stable combustion.
- Each cycle's similarity to ensemble average is quantified by:

$$R_P = \frac{(D^{(1)}, D^{(2)})}{\|D^{(1)}\| \cdot \|D^{(2)}\|}$$

- At higher speed, ignition and combustion stability become dependent on flow type.
 - High COV without swirl.
- E30 and gasoline both require tail ignition for acceptably low soot.

- Spray-swirl interactions ensure efficient flame spread throughout piston bowl.
- Conceptual model explains flow physics.

Stratified operation using Gasoline @ 2000 rpm

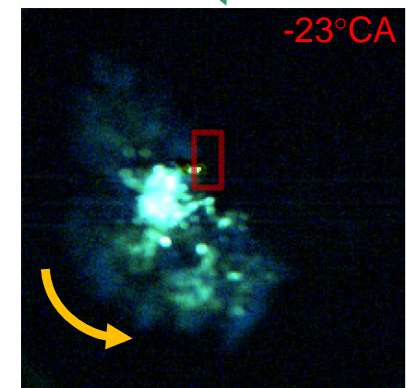
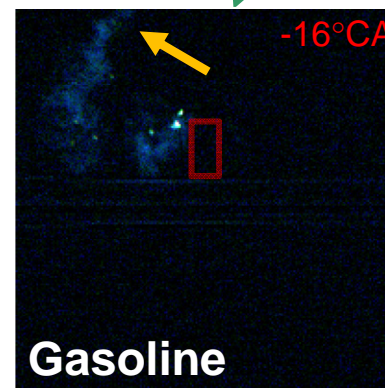
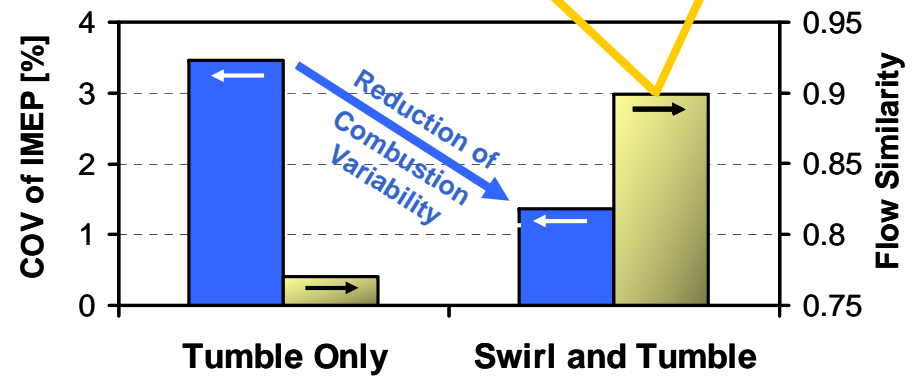
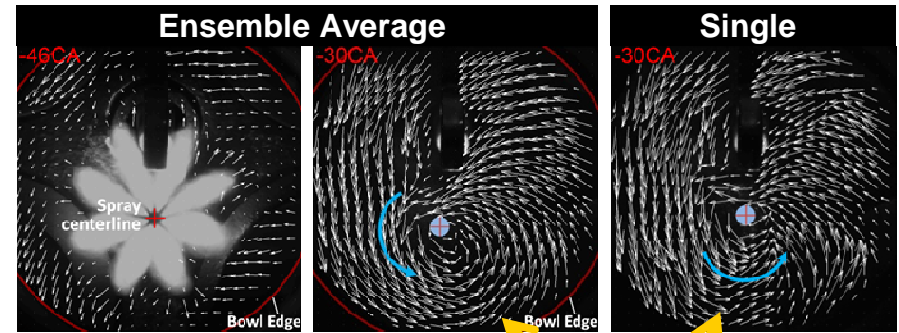

- For highest efficiency, downsizing and turbocharging should be combined with lean stratified operation.
- Does E30 pose challenges here?
- Study boosted operation.
 - Include double-injection strategy.
- Initial results indicate similar characteristics:
 - Liquid spray penetration.
 - Heat-release rate.
 - Combustion stability for low NO_x operation.
 - Low soot with double injections.
 - Flame-spread patterns.

• E0 – E30 blends appear compatible with highly efficient boosted stratified operation.

- Expanding study to higher engine speeds.
- Broaden conceptual model to include double-injection strategies.

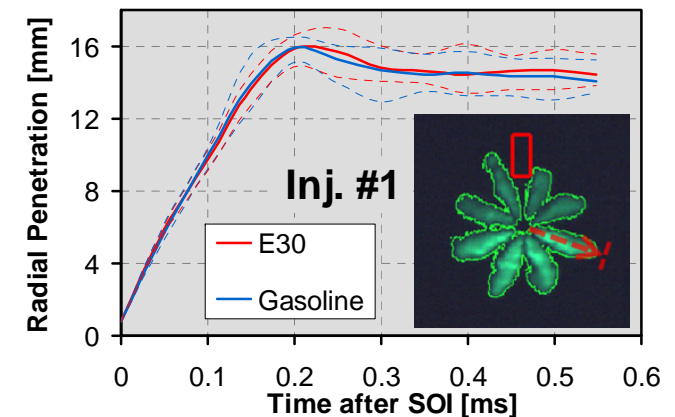
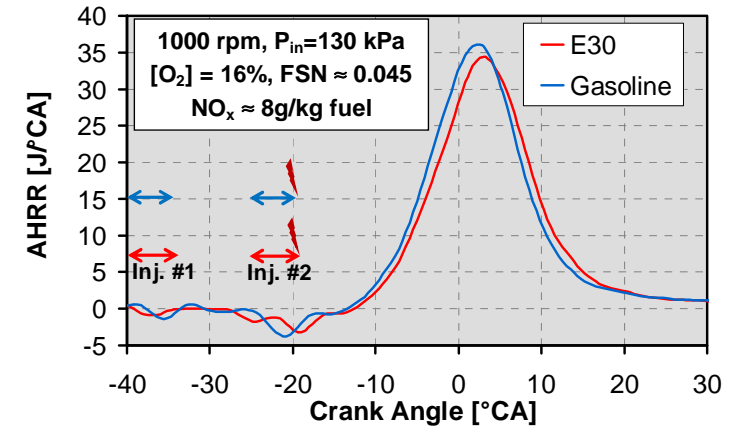
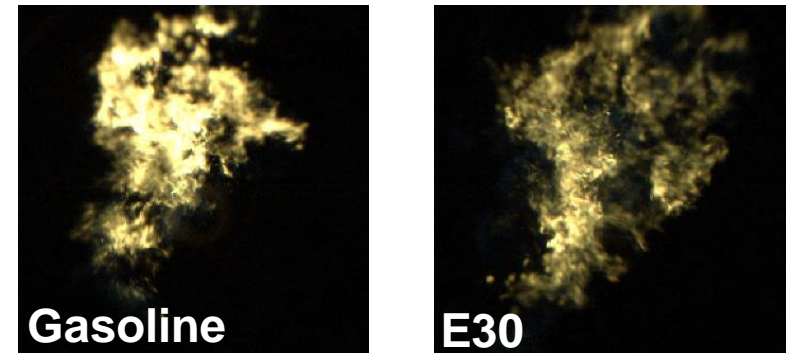

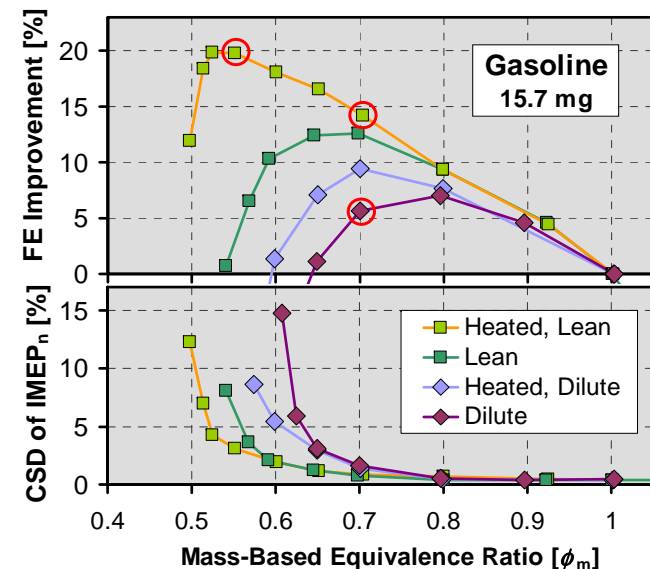
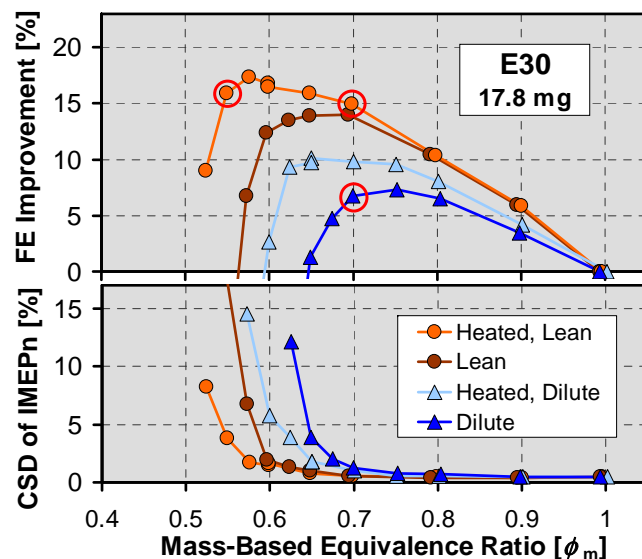
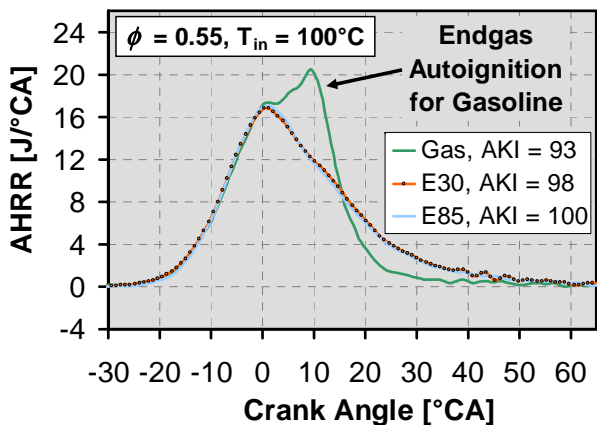

- Intake air heating improves lean operation for both E30 and gasoline.
 - FE gain is less for E30 (and E85). High octane number suppresses end-gas autoignition.
- Dilute stoichiometric operation with EGR offers much less gain for both fuels.
 - Worse combustion stability limits as well.

- Very slow flame-kernel development at low [O₂] conditions.
 - Strong need for enhanced ignition.

- Dilute operation shows nearly identical AHRR for E30 and gasoline.
 - Interplay between fuels and operating conditions.

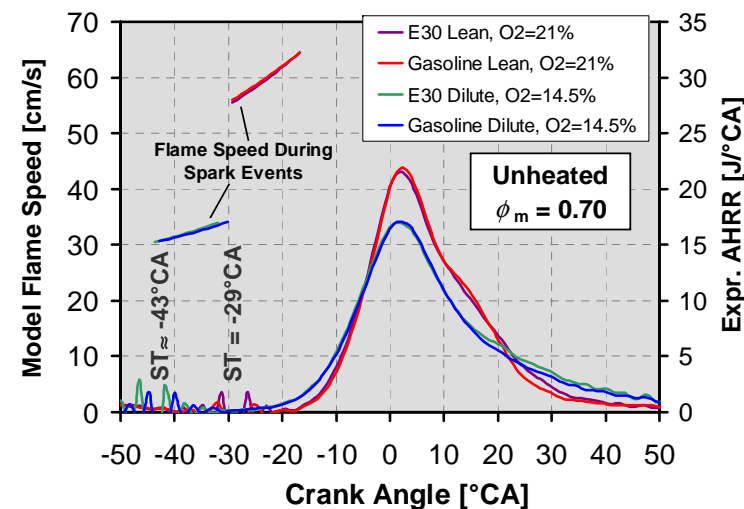

- Collaboration with TPS Inc.
 - Multi-pulse (MP) transient plasma.
 - High-voltage/current, but short pulses.
- Desirable to subject a large reactant volume to energetic electrons.
 - Electrode configuration important.
- Ultra high-speed imaging of plasma.
 - Electrodes show differences.
- Imaging reveals stabilized deflagration.
- MP is effective also for dilute operation.
 - Much faster inflammation.

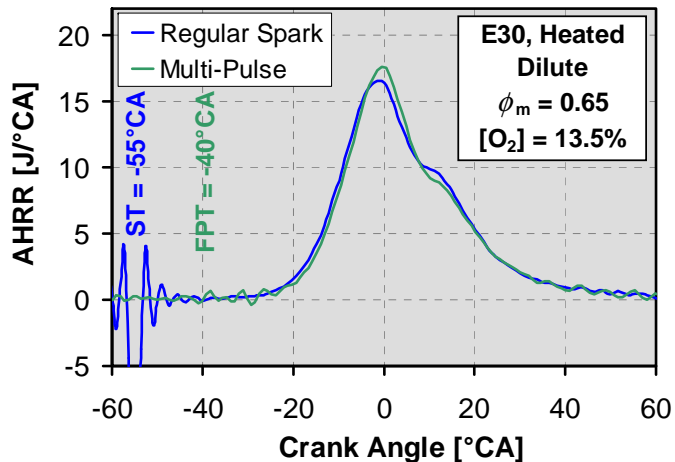

Plasma Imaging @ 100,000 fps

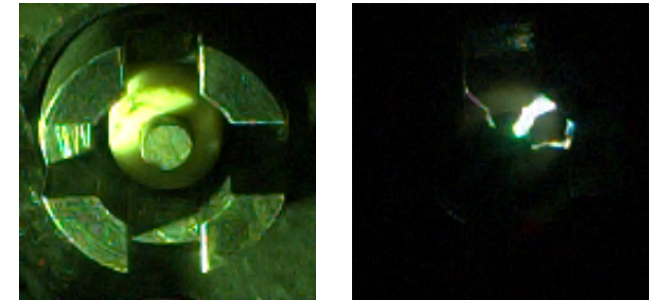

Cycle-to-cycle Flame Variability @ -22.5°CA

MP Ignition

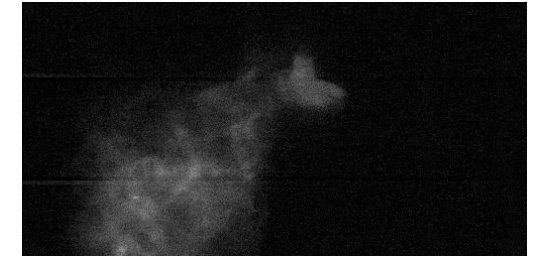

Regular Spark

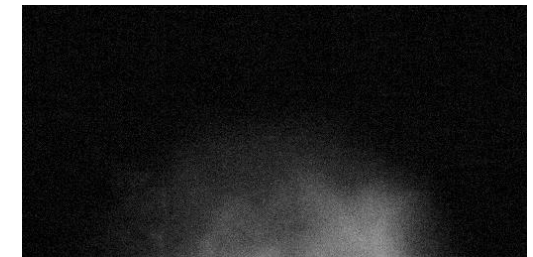

- Multi-pulse transient plasma improves potential of both dilute and lean operation by speeding up transition into fully turbulent combustion.

Lean E30 – Improved Combustion Control with MP

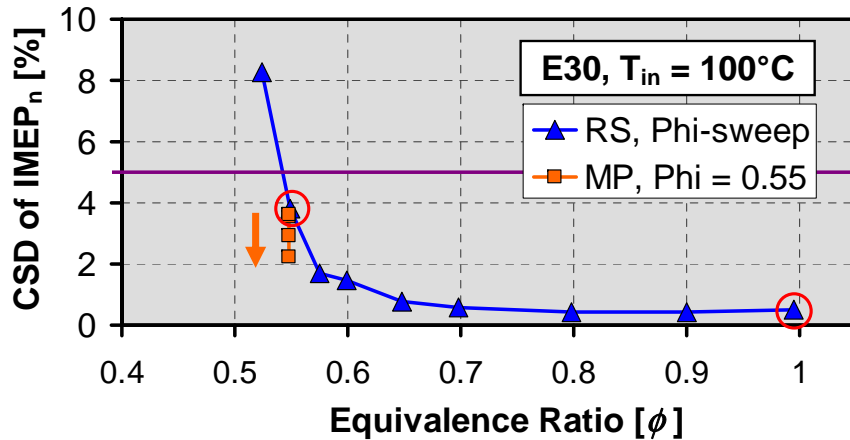

- Near lean-stability limit:
 - Regular spark (RS) has lost most of its

$$\text{control authority} = \frac{\Delta CA_{10}}{\Delta ST}$$

- 10-pulse transient plasma ignition (MP) doubles control authority.

- Shorter Ignition-to-CA10 delay.
- Use to lower variability (see back-up slide).
- Still, better control authority is desirable.

- Partial fuel stratification offers very strong control, even for ultra-low ϕ .

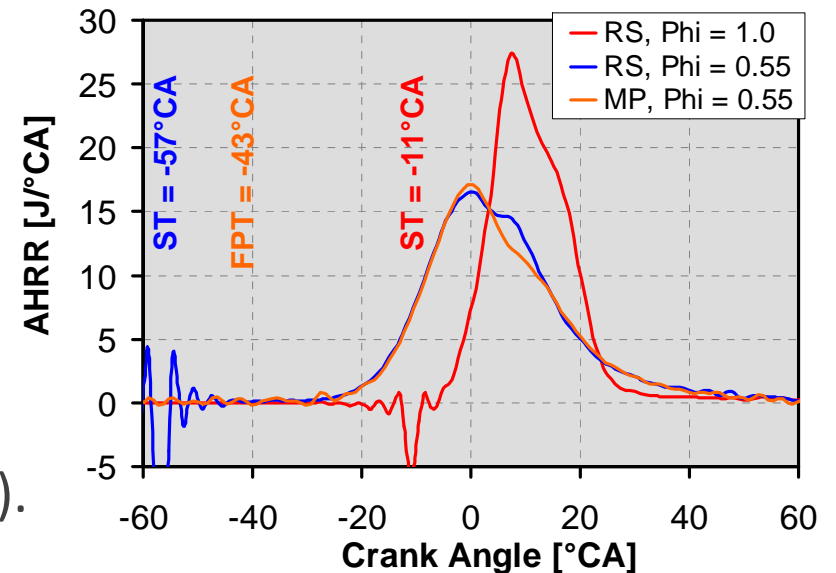
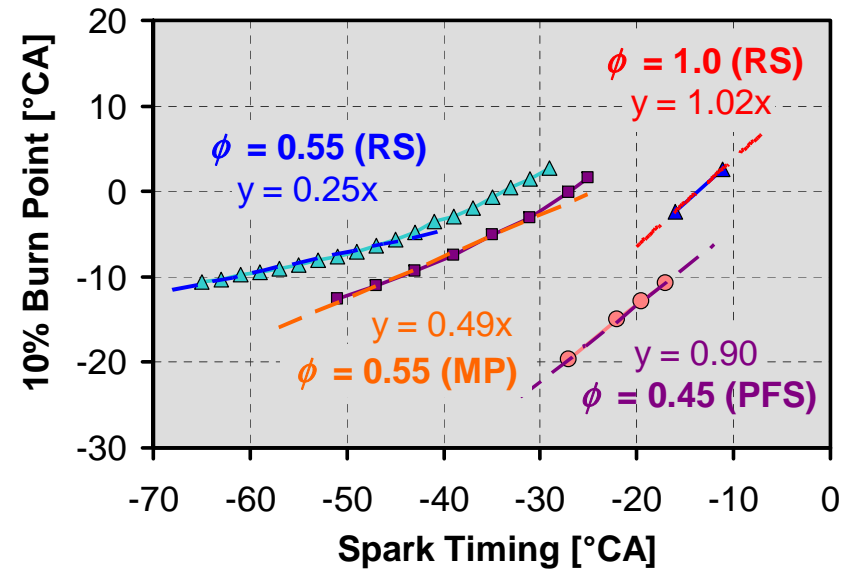

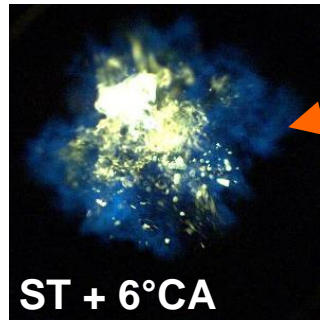
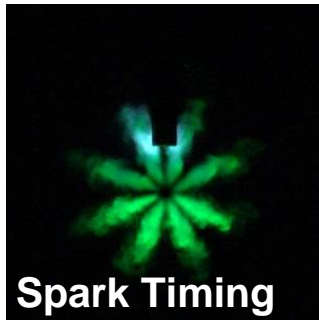
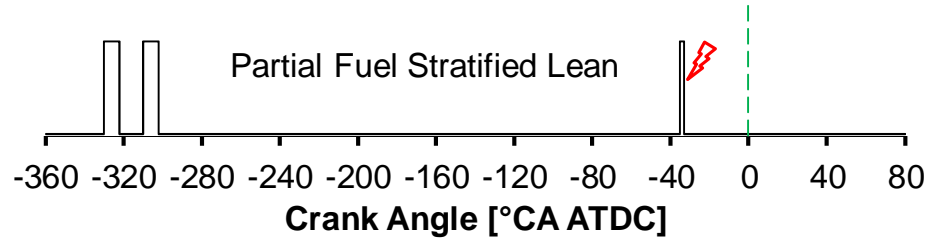

Enhanced Early Burn

- PFS allows studying the ultimate limits of deflagration-based SI operation.

- Ultra-lean SI combustion requires end-gas autoignition for high combustion efficiency (CE).

- With strong control authority:
 - Autoignition is possible by advancing ST, even for E85 with AKI = 100 .
 - Combustion is very repeatable.

- Spray-guided design allows small pilot injection at spark timing.

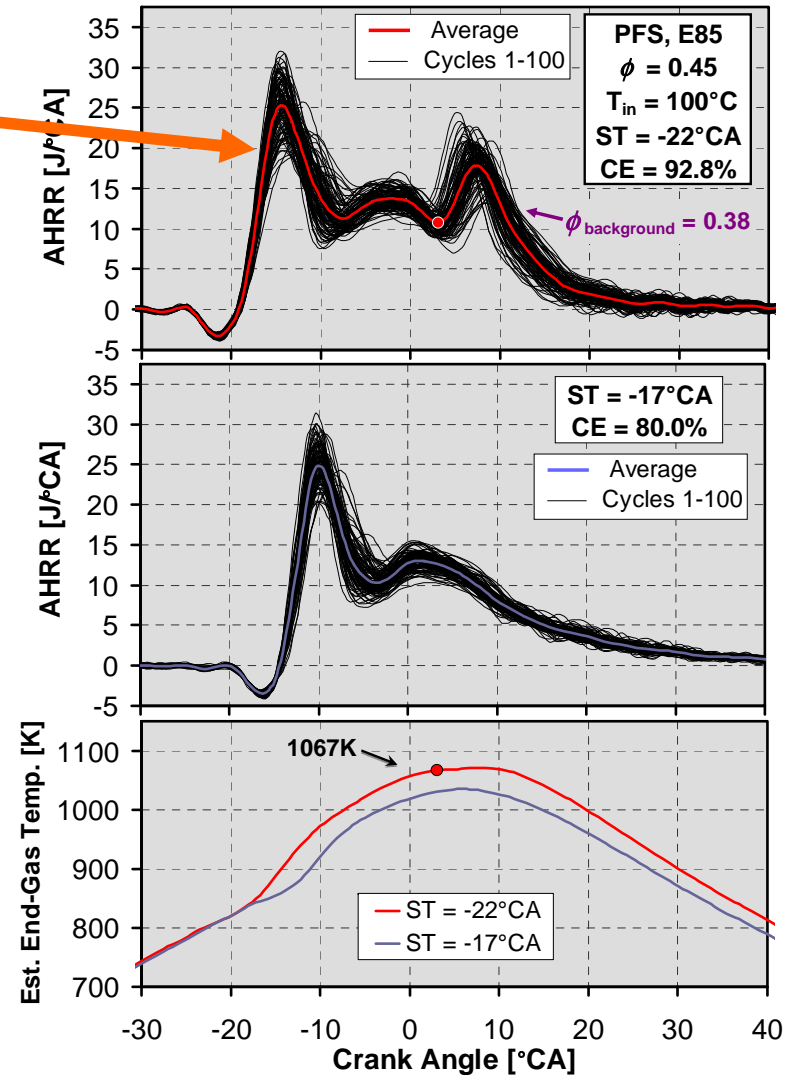

- General Motors.
 - Hardware support, discussion partner.
- Toyota Motor Corporation.
 - Funds-in fuel- and knock-effects project.
 - Leverages DOE project.
 - Example of downspeeding with E30.

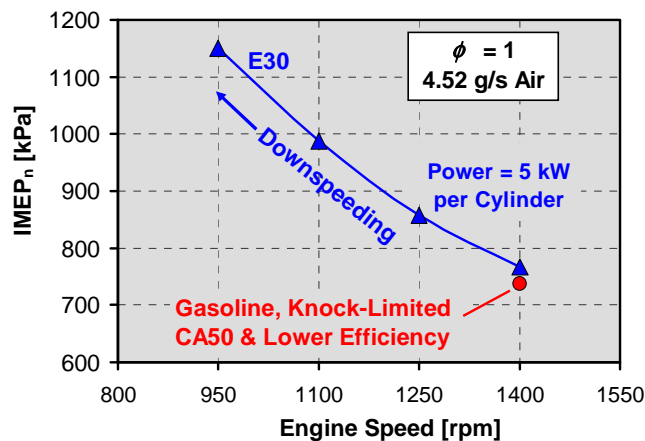

- D.L. Reuss (UM).
 - Cyclic-dispersion expertise.
- 15 Industry partners in the Advanced Engine Combustion MOU.
 - Biannual on-site meetings and frequent WebEx meetings.

- LLNL (W. Pitz and M. Mehl).
 - Development of mechanisms for gasoline-ethanol surrogate blends.
- Low S_L for dilute operation explains required early spark timing.
 - Reduction of $[O_2]$ suppresses heat release in 1000 – 1300 K range.

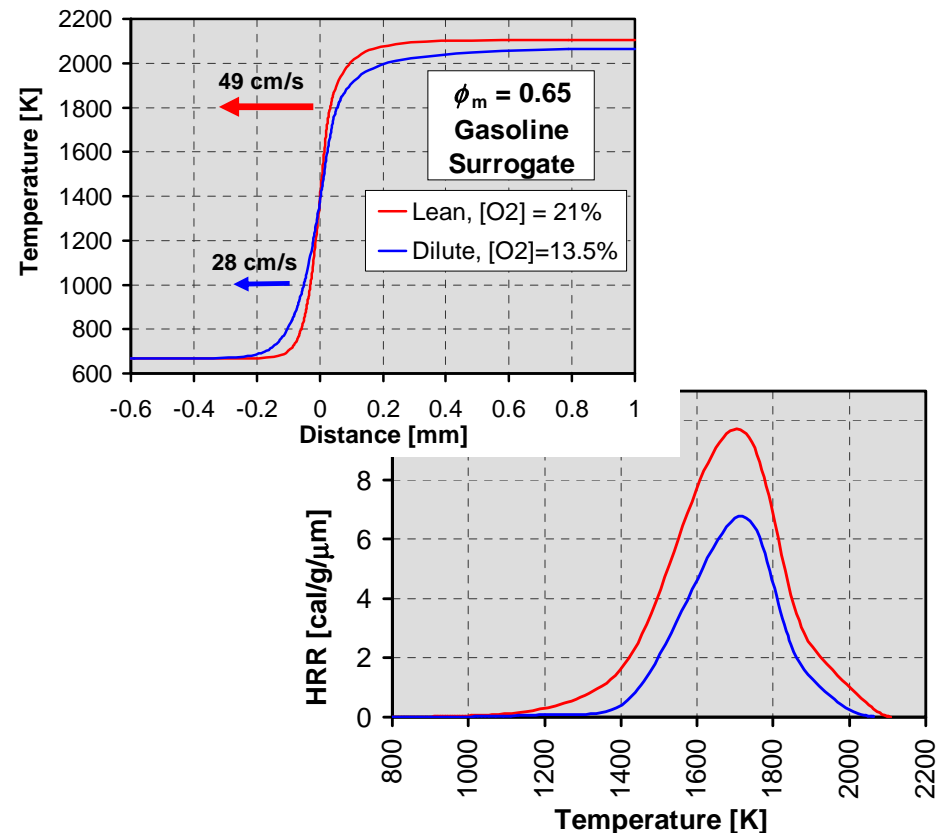

- LLNL (R. Whitesides).

- CFD modeling of spray/flow interactions.

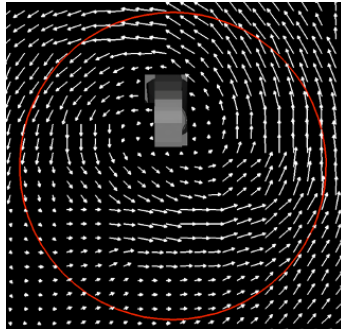

- Stratified combustion with E85.

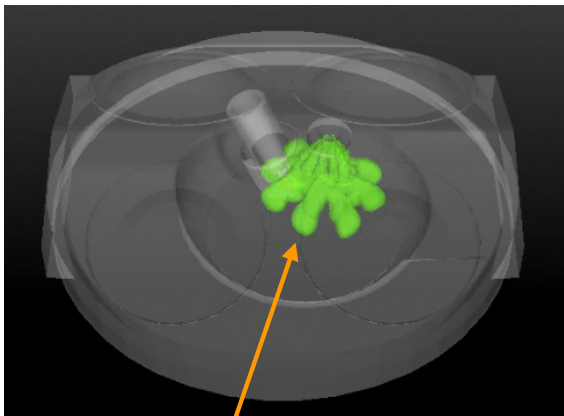

- Sandia (M. Musculus)

- IR-vapor temperature imaging.
- Validation data for fuel-jet penetration and vaporization cooling.

- Transient Plasma Systems.
 - Multi-pulse advanced ignition.

- Istituto Motori (C. Tornatore)

- Development and application of flame-spectroscopy diagnostics.
 - Well-mixed calibration shows very similar spectra for E30 and gasoline.
 - Probe PFS operation. Use ratios of peaks for evaluation of ϕ in flame front.

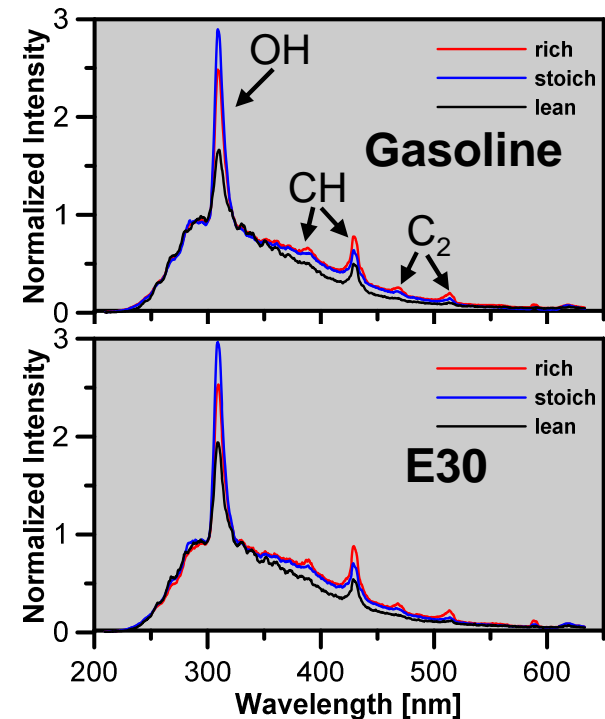



Address Previous Reviewers' Comments

- **Overall, the evaluations were very positive.**
- **Below are responses to selected areas of concern that the reviewers expressed.**
- *Questions 3: “As with most of the projects that claim collaboration through the AEC MOU Working Group, it is not clear if the interactions only consist of the questions asked during the twice per year presentations, or if they are more extensive.”*
- **Response:** During the past 15 months, we have presented research results at 15 in-depth technical WebEx meetings and teleconferences with three of the major US OEMs and the USCAR ACEC Tech Team.
- *Questions 3 & 4: “Several reviewer commented on the need to find a CFD simulation partner.”*
- **Response:** Starting FY15, LLNL has received funding for fuels-related modeling efforts. Consequently, we are working with LLNL on both chemical-kinetics modeling and CFD. This is work in progress but valuable fundamental insights have already been gained, as exemplified in this presentation.
- *Feedback from a reviewer for Question 4: “...it would be very interesting to compare these ethanol studies, particularly the sooting behavior relative to ignition location and oxygenate content, with studies of butanol.”*
- **Response:** In addition to ethanol, we would also like to work on other fuel components, but with limited funding it is important to focus on fuel blends that the US industry partners consider relevant. The new Optima project may offer opportunities for more research to provide a more holistic fuels view.
- *Question 4: “The reviewer would like to see a more holistic evaluation of the combustion strategies, such as ability to be fuel-robust, the ability to work with conventional aftertreatment, and more information about operating ranges and limits.”*
- **Response:** We agree that this would be valuable. Hence, we will strive towards more holistic evaluation of fuels and combustion strategies. The challenges is that these combustion modes are not-yet fully understood, even with regular gasoline. Consequently, the holistic view cannot be developed fully until fuel effects are understood at a fairly detailed level for each combustion strategy.



Future Work FY 2016 – FY 2017

- Continue studying effects of E0 - E30 fuels on boosted stratified SI operation.
 - Higher speeds, comparing single- and double-injection strategies.
- Expand conceptual model of swirl-spray stabilization mechanism for stratified operation to include double injections.
- Refine partial fuel stratification (PFS) technique to allow the use of a smaller pilot-fuel quantity.
- Collaborate on emerging advanced-ignition hardware.
- Continue examination of well-mixed lean or dilute SI operation.
 - Apply PFS to examine fuel effects on limits of ultra-lean SI combustion.
 - Use advanced-ignition hardware when it enhances fuels research.
- Compare stoichiometric knock limits with ability to achieve beneficial end-gas autoignition for ultra-lean SI operation.
 - Investigate relevance of RON & MON for fuel reactivity under ultra-lean conditions.
- Continue collaboration on CFD and flame modeling.
 - Provide validation data. Work towards predictive modeling.
 - Gain insights of governing chemistry and flows.

- This project is contributing strongly to the science-base for the impact of alternative fuel blends on advanced SI engine combustion.

1. DISI with spray-guided stratified charge combustion system

- Developed a conceptual model of the swirl-spray interactions that stabilize both flow field and stratified-charge SI combustion.
- Initial results suggest that E0 - E30 fuel blends are equally compatible with highly efficient stratified-charge SI operation.
 - Expand study to include boosted operation at higher speeds, contrasting single and double injections for E30 & gasoline.

2. DISI with well-mixed lean or dilute combustion system

- Very slow flame-kernel development with regular spark system impedes potential of dilute EGR operation .
 - Low $[O_2]$ strongly reduces HRR in 1000-1300K range \Rightarrow wider pre-heat flame zone \Rightarrow lower S_L .
 - Multi-pulse transient plasma ignition speeds up inflammation for both dilute and lean operation.
- Ultra-lean SI operation requires end-gas autoignition for high combustion efficiency.
 - Autoignition reactivity of the fuel becomes a key parameter for such mixed-mode combustion.
 - Enhanced ignition can reduce or eliminate knock concerns.
- Partial fuel stratification can be used as a powerful igniter.
 - Use as a tool for understanding relevance of RON & MON for ultra-lean SI operation.



Technical Back-up Slides

Stochastic Variations of Flow Pattern @ 2000 rpm

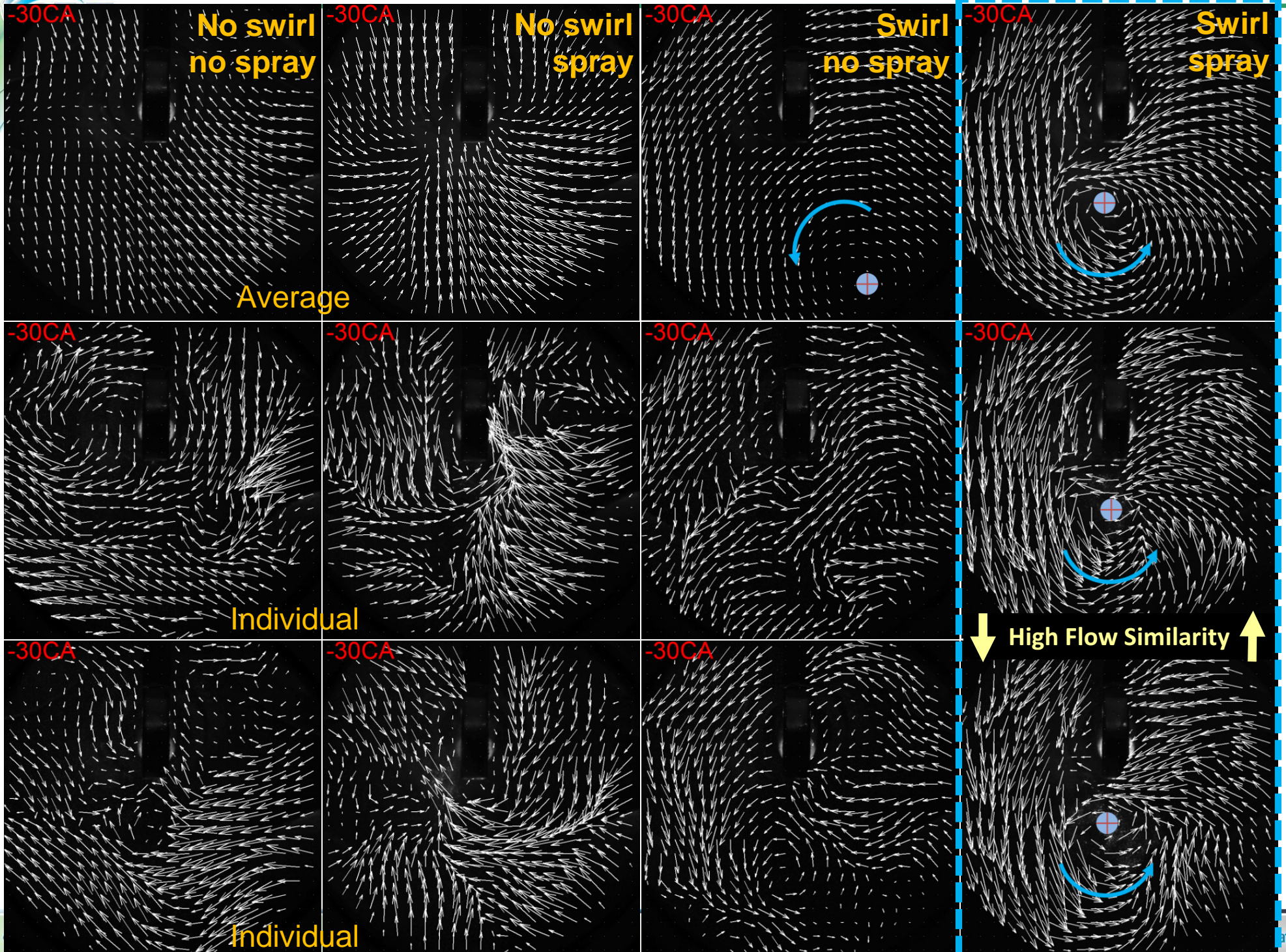

Definitions of Equivalence Ratio

- Traditional definition based on amount of air:

$$\phi \equiv \frac{\left(\frac{F}{A}\right)_{Actual}}{\left(\frac{F}{A}\right)_{Stoichiometric}}$$

- Reflects well temperature rise during combustion solely when air dilution is used.

- Definition used here for operation with diluents other than only air:

$$\phi_m \equiv \frac{\left(\frac{F}{C}\right)_{Actual}}{\left(\frac{F}{A}\right)_{Stoichiometric}}$$

- Reflects well temperature rise during combustion for dilution using air in combination with other gases (*e.g.* EGR or N₂).
- ϕ_m is a measure of chemical energy per reactant mass, regardless of type of diluent.
- F = Fuel mass.
- A = Air mass.
- C = Gas Charge Mass (in this case Air + N₂).

Improved End-gas Autoignition Control



- Better control with MP allows later CA50 for ultra-lean SI gasoline operation.
- Average burn-point for end-gas autoignition shifts 58 to 62% \Rightarrow
 - CAI portion reduced from 42 to 38%.
 - More repeatable combustion.
- Fewer outlier cycles \Rightarrow Knock index (KI) for top-10% cycles cut in half.

