

Laboratory Evaluation of EGS Shear Stimulation

Project Officer: S. Porse, D. King
 Total Project Funding: \$800k
 May 14, 2015

Stephen Bauer
 Sandia National Laboratories
 Ahmad Ghassemi
 Oklahoma U

Track Name

Laboratory Evaluation of EGS Shear Stimulation

Organization: Sandia National Laboratories / Geothermal Research
Principal Investigator: Stephen Bauer
Contact information: email: sjbauer@sandia.gov; Ph: 505-844-9116
Project Team: Ahmad Ghassemi, Qinglu Chen University of Oklahoma,
Perry Barrow, Sandia National Laboratories

To produce laboratory-based experimental and numerical analysis results that will provide a physics based understanding of shear stimulation phenomena (hydroshearing) and its evolution during stimulation. Water will be flowed along fractures in hot and stressed fractured rock, to promote slip.

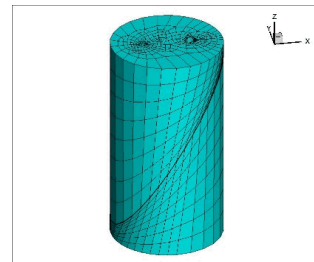

- **Provide insight to the role of fracture slip on permeability enhancement- “hydroshear”**
- **Provide insight toward the relationship between pore pressure and thermal stress and fracture shear deformation, fluid flow and AE.**
- **The goal of the project is to study the response of fracture shear deformation induced by fluid flow resulting from pore pressure changes and cooling in reservoir stimulation using laboratory experiments and modeling**

The work will provide valuable input data for stimulation models, thus helping design effective EGS.

- **Development of a laboratory based experimental system**
- **Development of analysis methods to model experiments**
- **Cross pollinate results between experiment and analysis**
- **Better understand hydroshear phenomena**

Sample geometry

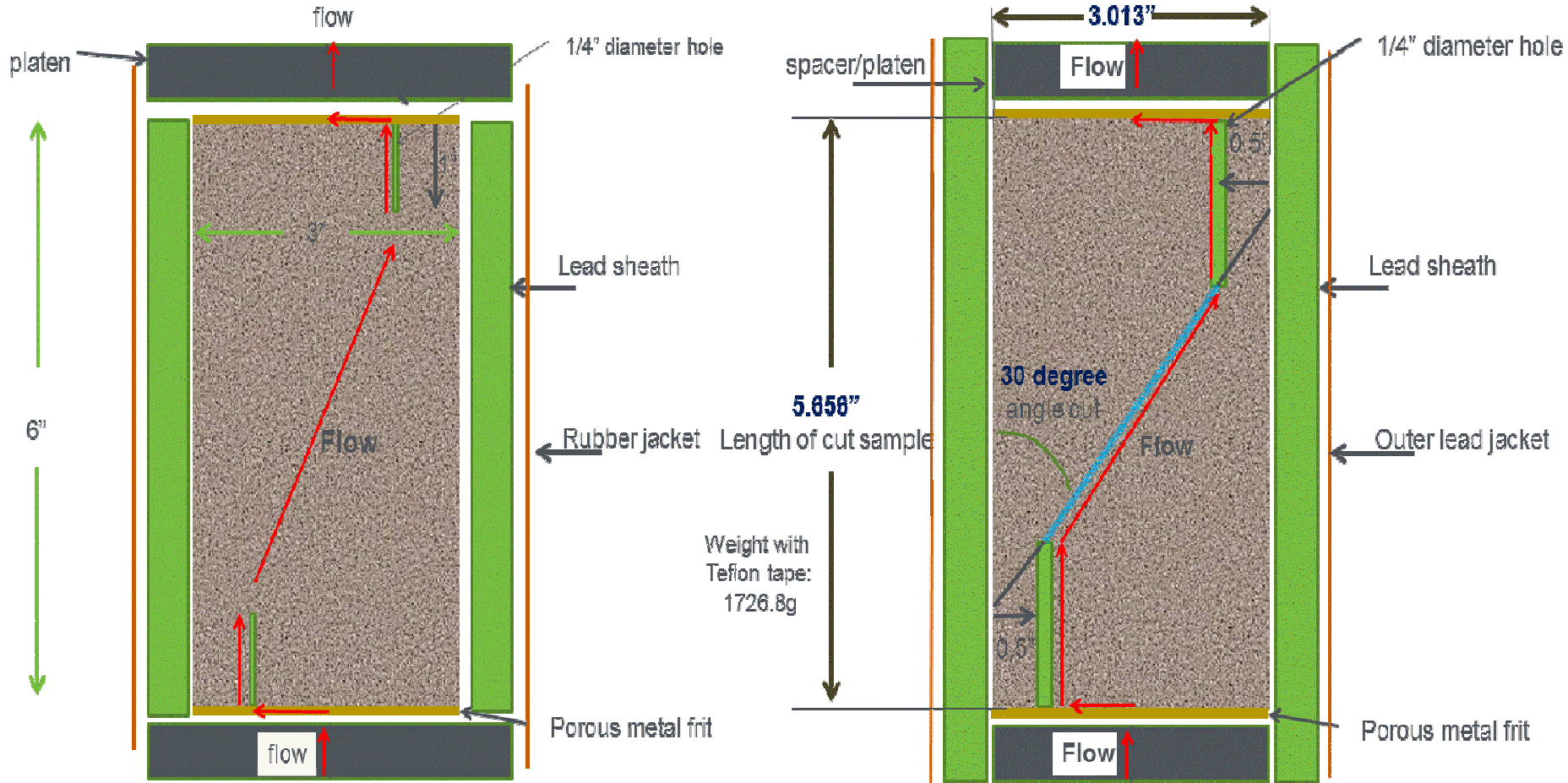

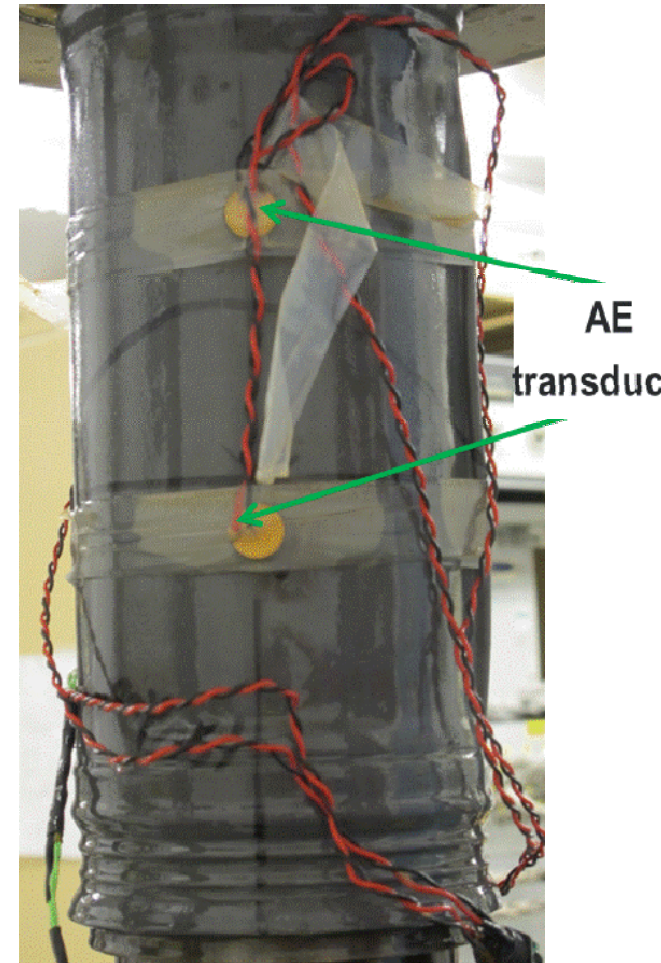
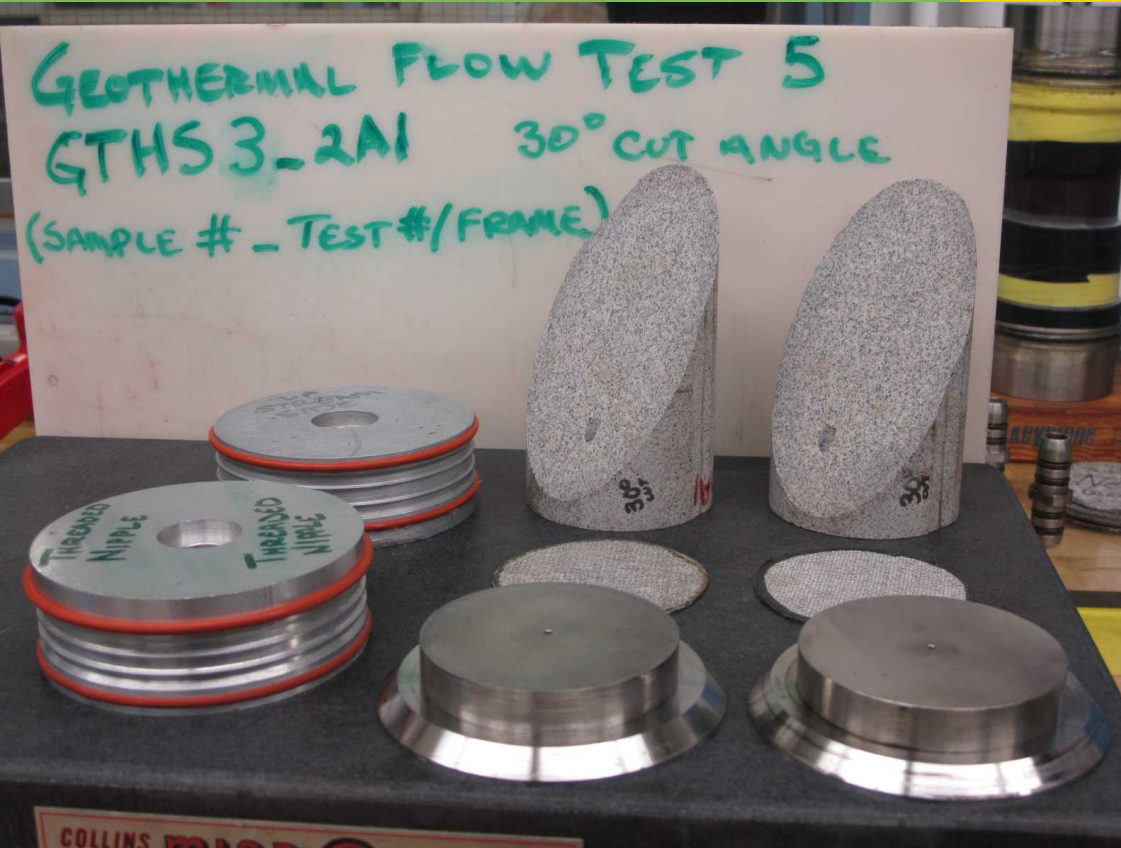

- **Confining pressure: 3000 psi**
- **Temp: 175°C**
- **Differential Stress, Effective Stress, Pore Pressure: Varied**
- **Pore water temp 20°C+**

Pressure
vessel

Reaction
Frame

Load
Cell

Electronics
in

Flow in

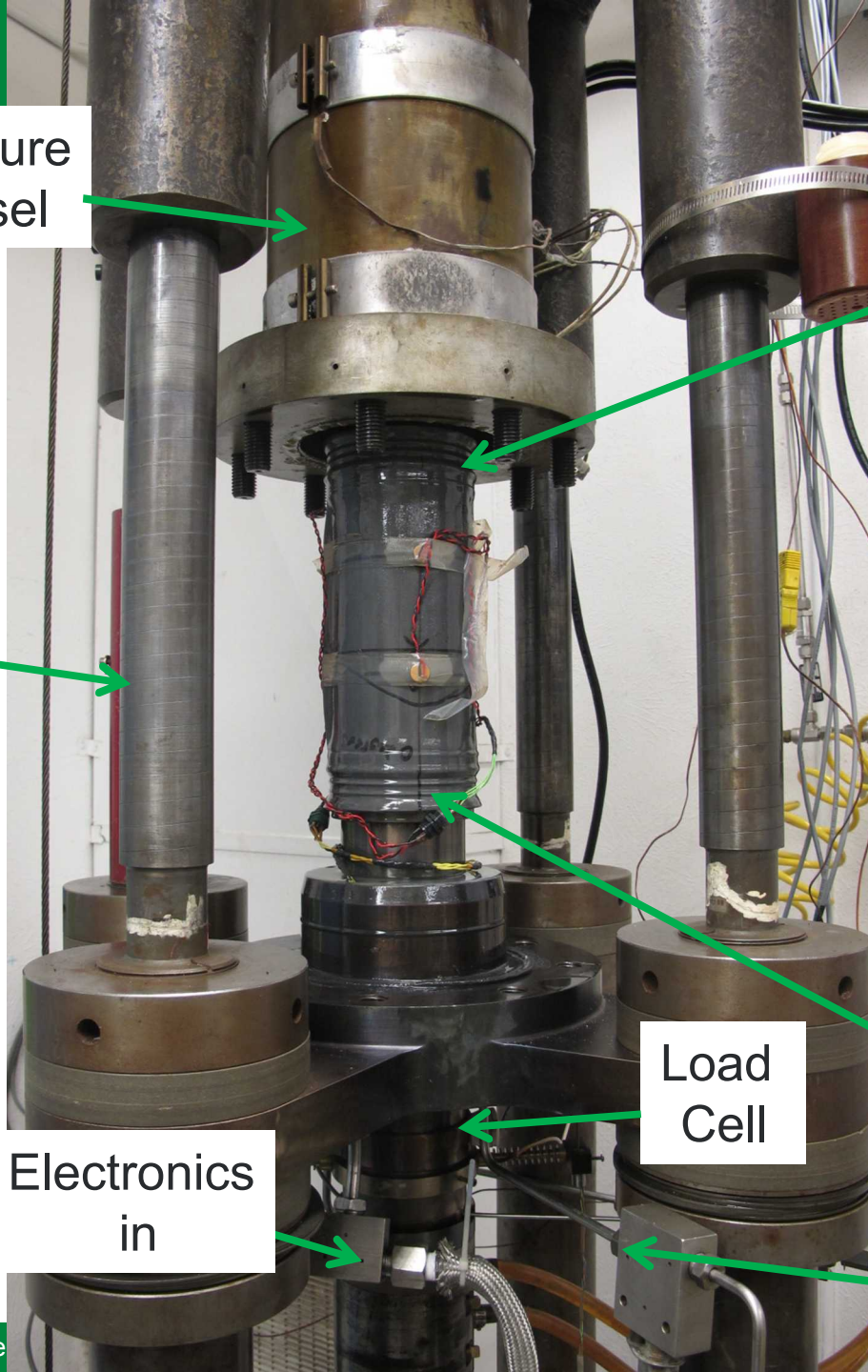

Test system

Pressure vessel

Load frame

DAS/GUI

Pore pressure system

Instrumented sample

The screenshot displays a comprehensive control interface for the test system. It includes several key sections:

- Test Control:** Radio buttons for 'Act. Press', 'Axial Stress', and 'Load'. Parameters include Mode (Auto/Man), Auto Setpoint (100.0), Deadband (8.0), and Hysteresis (2.0).
- Confining Pressure Control:** Controls for 'Activate Servo' (Enabled), Mode (Auto/Man), Auto Setpoint (3000.0), Control Deadband (15.0), and PID Tuning.
- Temperature Readouts:** A grid of temperature sensors including DownStream-A (2496.73 psi), UpStream-B (2507.30 psi), Generic #2 (0.00), Amb. Temp (22.2), UV Temp (22.5 °C), Avg. Temp (22.5 °C), LV Temp (22.5 °C), Piston Temp (22.6 °C), and L.C. Temp (24.6 °C).
- Sample Information:** Fields for Test Name (Test Sample ABC), Test Start Date (03/19/2014), Diameter (3.0130), Length (5.6560), Initial Volume (0.0000), Calc. Volume (0.0000), Initial Area (7.1264), and Calc. Area (0.0000).
- Frame Dimensions:** Piston Diameter (3.5000) and Ropie Diameter (0.7500).
- Offset Controls:** Tables for LVDT1 (Ls), LVDT2 (Sm), Load, and Conf. Pressure, each with Offset Value and Offset Cntrl.
- Test Timers:** Test Duration (211.779), Step Interval (16.245), Delta Interval (1.5000), and Chamber Power (0.017).
- Act. Stress:** Real-time readout of 104 psi.
- Other Readouts:** PXN Force (27462 lbf), Load Cell (28298 lbs), Inc. Relay, Down Str Vol (199.2 mL), Up Str Flow (0.00 mL/min), and Acoustic Emiss (000000).
- Function Keys:** F1-F12 keys for navigation and control, such as 'F1 CB Overview', 'F2 CB Gage Setup', 'F3 Historical', 'F4 CB Alarms', 'F6 A-Frame', 'F7 AF Gage Setup', 'F8 AF Historical', 'F9 AF Alarms', 'F11 Print', and 'F12 Note Pad'.

Test Conduct

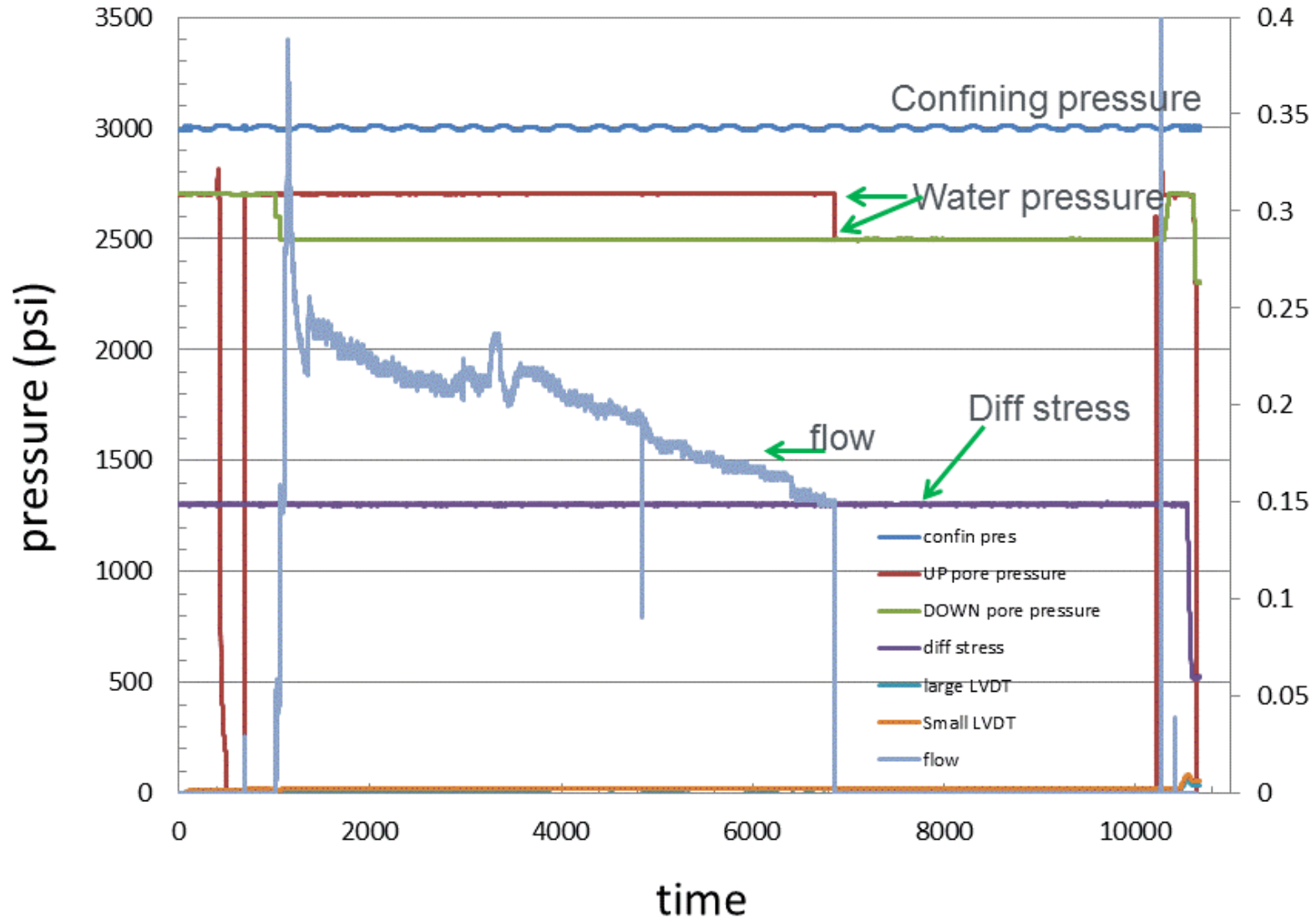

Test results during flow

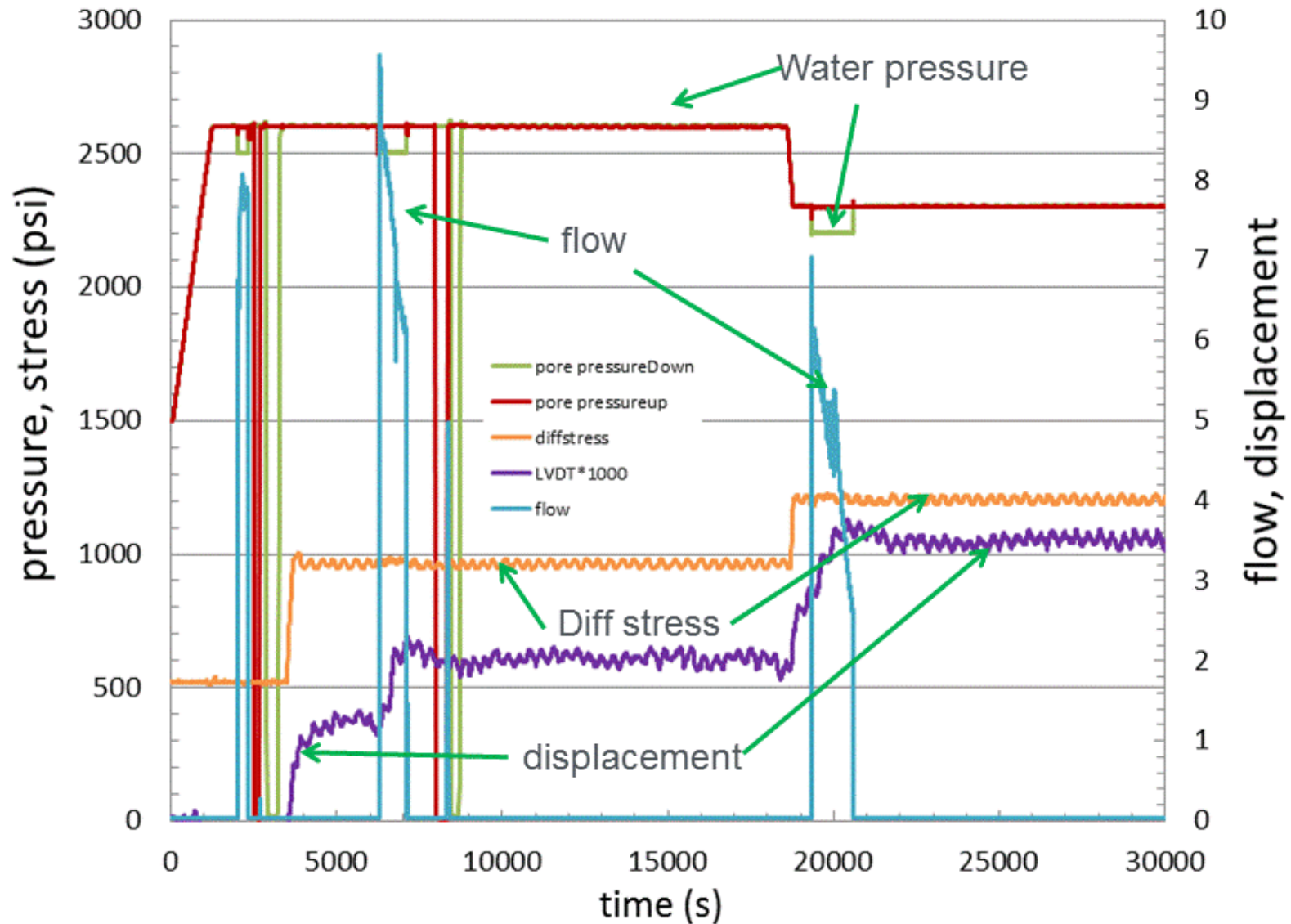

Problem Description

This study involves a thermo-poroelastic analysis of a lab experiment in which a granite core specimen is subjected to water injection. The diameter and length of the specimen is 3 inch and 6 inch, respectively. Two boreholes of 0.25 inch diameter are drilled on the sample as shown in Figure 1. A diagonal fracture is introduced to simulate a fractured system. The sample is under 3000 psi confining pressure, and 4300 psi vertical stress. The initial pore pressure is 1000 psi. The pressure on the surface of the boreholes is controlled in 3 stages: 2700 psi, 2500 psi, and 2700 psi, according to experimental data (TA GTHS3_2A1-5-SlipTest-11-03-14sjba (2)). The initial temperature of the sample is 175° C and it is fixed on sample surface to simulate a constant temperature boundary. During the simulation, the heat source at the upstream borehole is held at 20° C. The properties used in the simulation are summarized in Table 1. Fracture permeability is assumed to be 1×10^5 larger than matrix permeability.

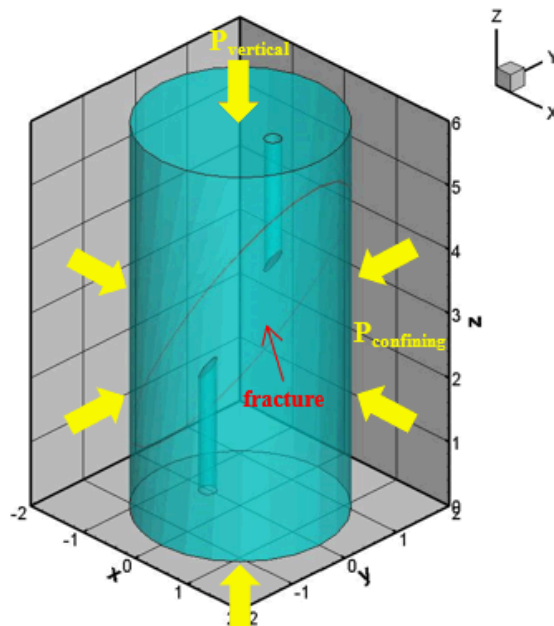

Figure 1. Specimen geometry

Young's modulus E	15.0 GPa
Biot's coefficient α	0.44
Drained Poisson's ratio ν	0.25
Undrained Poisson's ratio ν_u	0.33
Permeability coefficient k	$4 \times 10^{-19} m^2$
Porosity ϕ	0.01
Skempton's coefficient B	0.81
Fluid viscosity μ	$3 \times 10^{-4} Pa \cdot s$
Fluid diffusivity c	$7 \times 10^{-5} m^2 / s$

Table 1. Rock properties.

Finite Element Model

Finite element formula of the governing field equations are derived using Galerkin's discretization in the space domain and Crank-Nicolson approach in the time domain. In this simulation, Cartesian mesh is used, and the specimen is discretized into 5730 hexahedral elements and 6527 nodes, as shown in Figure 2.

$$\begin{bmatrix} K & -C_{up} & -C_{uT} \\ C_{pu} & K_p + \Delta t C_{pp} & -C_{pT} \\ 0 & 0 & C_{TT} + \Delta t(K_{cdT} + K_{cvT}) \end{bmatrix} \begin{bmatrix} \Delta u \\ \Delta p \\ \Delta T \end{bmatrix} = \begin{bmatrix} \Delta t \dot{F}_u \\ \Delta t F_{qin} - \Delta t C_{pp} p_{t-\Delta t} \\ \Delta t F_{hin} - \Delta t (K_{cdT} + K_{cvT}) T_{t-\Delta t} \end{bmatrix}$$

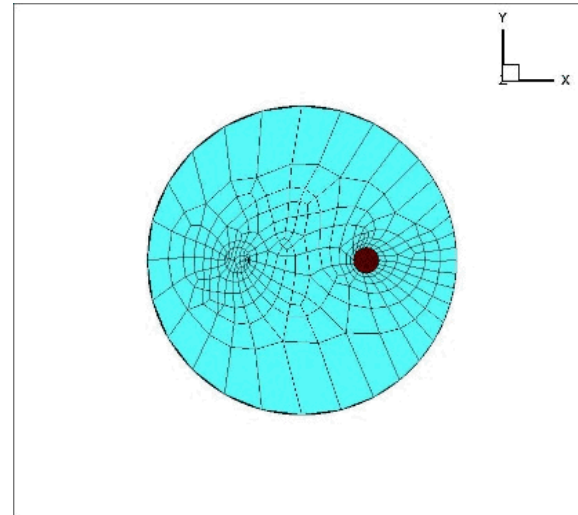
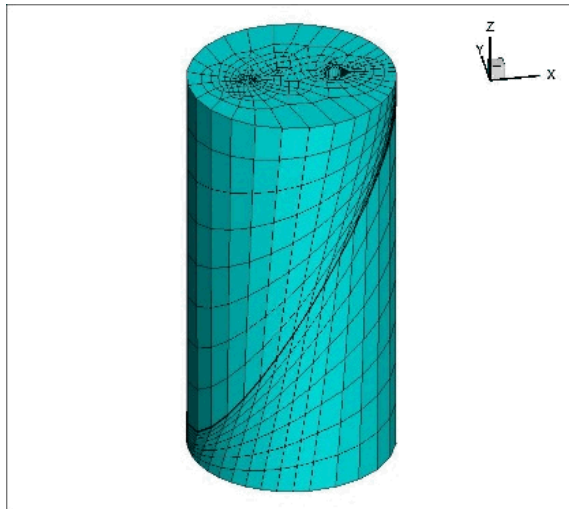

Figure 2. Finite element model

Simulation/experiment

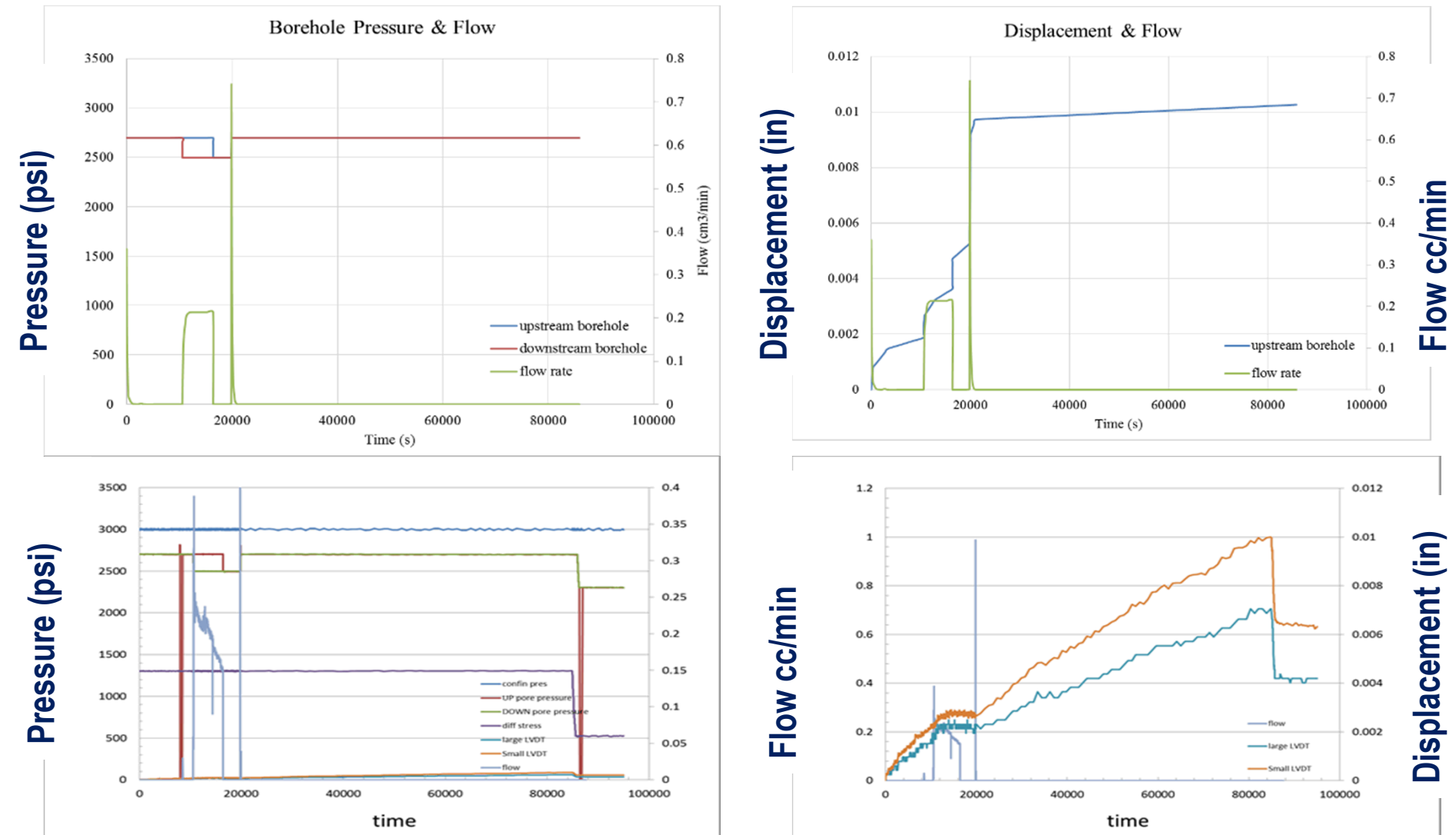

Figure 3. Borehole pressure, displacement, flow evolution with time.

Accomplishments, Results and Progress

Original Planned Milestone/ Technical Accomplishment	Actual Milestone/Technical Accomplishment	Date Completed
Milestone Name/Description	End Date	Type
Complete analysis based experiment design and select feasible experimental paths forward. In parallel, complete a portion of the first series of experiment(s) incorporating induced fractures. Tests will include fluid flow measurements at elevated temperatures and pressures (temperatures to be determined through preceding analyses). Parallel analysis and experimental work effort will help improve progress.	Designed and fabricated experimental system, system designed based on a combination of experience, and stretching of test system (flow through at high temperature, long test time duration, high temperature, pressure stable test environment	12/31/2014 (target) 11/30/2014-complete
Complete first series of experiments. Results from the experiments will be used to provide feedback to improve experimental design, experimental conduct, and data collected in the second series of experiments.	Check	3/31/2015 (target) 3/31/2015
Conclude and document first series experimental results.	6/30/2015	6/30/2015 (target) 9/15/2015-planned
(SMART) Assuming successful completion of go no go, Complete 2nd set of experiment(s) incorporating velocity measurements and AE transducers. Test will include fluid flow measurements at elevated temperatures and pressures (temperatures to be determined through analyses of preceding tasks). Report on FY15 activities through publication	9/30/2015	9/30/2015 (target) 12/30/2015-planned

- Measure AE events, correlate with slip events
- Determine surface profile
- Complete analyze of additional loading scenarios/boundary conditions
- Input to data repository
- Document results

Milestone or Go/No-Go			Status & Expected Completion Date
Test System Capability	Compare the test systems ability to conduct experiments with analysis based test requirements. If experiments cannot be performed to support the analytical activities the project should be ended.	See Above	6/30/2015

The experimental effort has developed a technique to conduct, observe and measure shear displacement resulting from introduction of cool water to a hot wet stressed fracture.

Induced displacement: flow, effective stress

The analysis effort has developed a method to model, observe and determine heat transfer, fluid flow and shear displacement shear displacement resulting from introduction of cool water to a hot wet stressed fracture.