

Smart Inverters in the United States

*Exceptional service
in the national interest*



Jay Johnson

Sandia National Laboratories, Albuquerque, NM, USA

Smart Inverter Workshop

14 November, 2014

Fukushima Renewable Energy Institute (FREA)
National Institute of Advanced Industrial Science and
Technology (AIST)
Koriyama, Fukushima, Japan

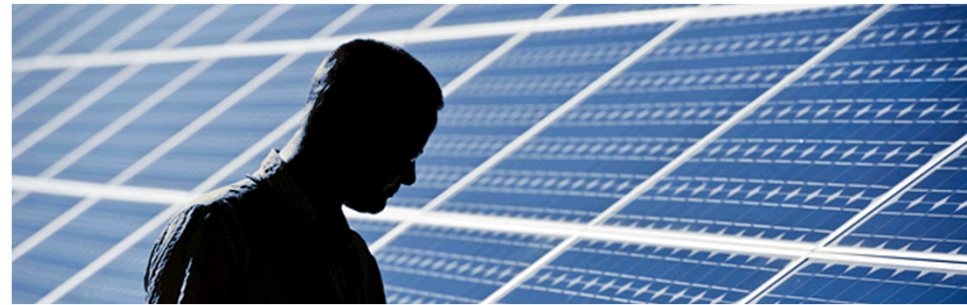

Outline

- The context
 - Total installed capacity of PV is growing fast in the US
 - Large growth expected in distribution systems
- The problem
 - Because the grid is slow to evolve, we will (already do!) encounter technical challenges
 - Unless mitigated, these challenges will make it increasingly difficult and costly to continue adding renewable energy to the grid
- Advanced inverters are a big part of the solution in the U.S.
 - Situation in the U.S. (and around the world)
 - California's Electric Rule 21 new proposed requirements
 - Projects:
 - California Solar Initiative Project
 - Smart Grid International Research Facility Network
 - Anti-islanding research at Sandia

PV capacity is growing fast in the US!

- 4.7 GW in 2013, 12.1 GW total
 - Installed capacity is projected to triple by 2016!
 - Highest growth rate expected in distribution-connected PV
- High-Pen PV Areas
 - California
 - ~2 GW of distribution-connected PV
 - Aiming for 12 GW of DG (mostly PV) by 2020! [1-2]
 - Hawaii
 - Highest penetration at the balancing area level (island grids)
 - Half of distribution circuits are at 100% of daytime minimum load

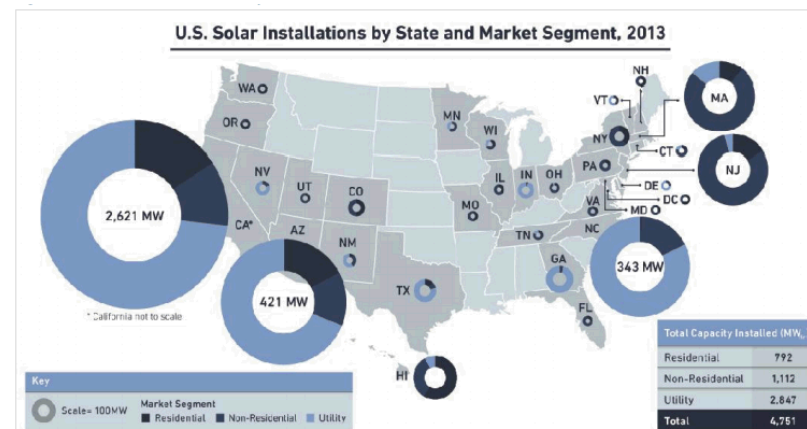
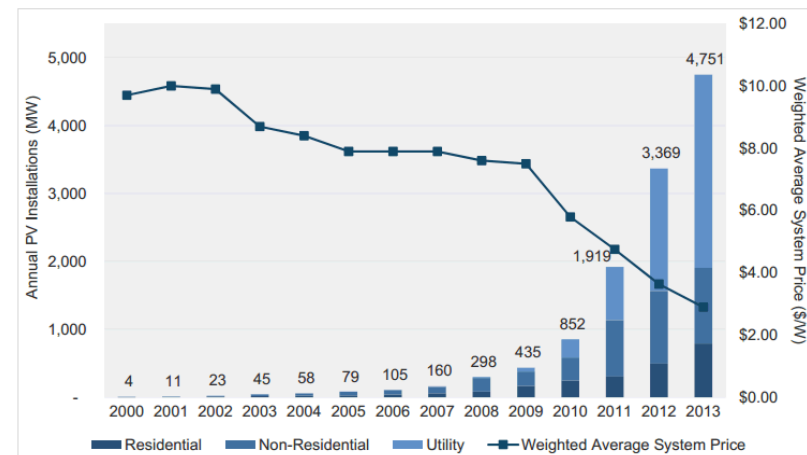

Source: SEIA/GTM Research, US Solar Market Insight 2013 Year in Review

Huge potential for further growth!

- US lags other countries in terms of installed capacity, but the future potential is much greater
 - How much of this potential can be tapped while maintaining high grid reliability and performance?

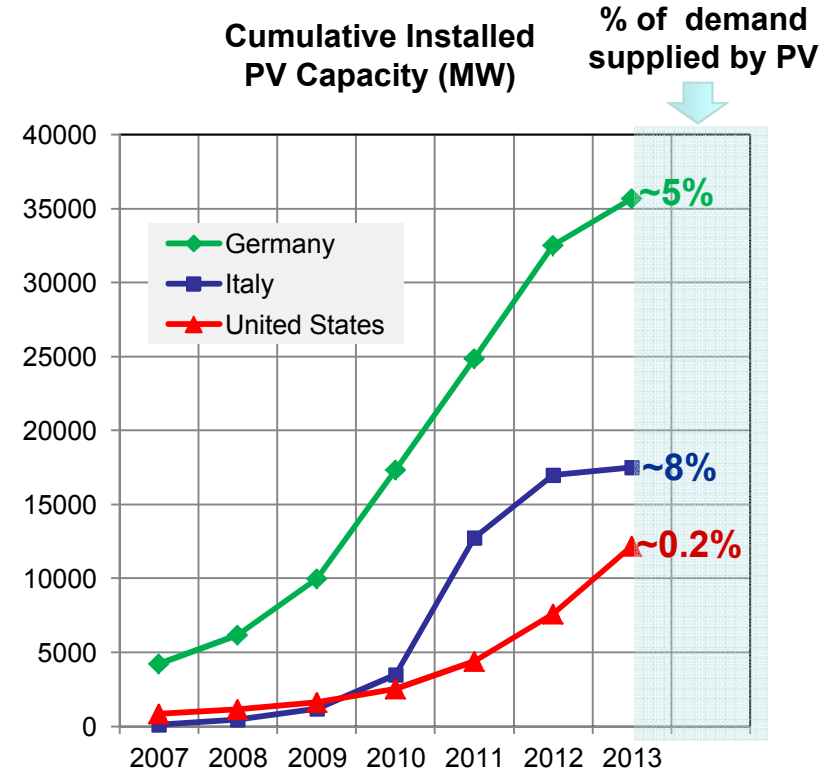
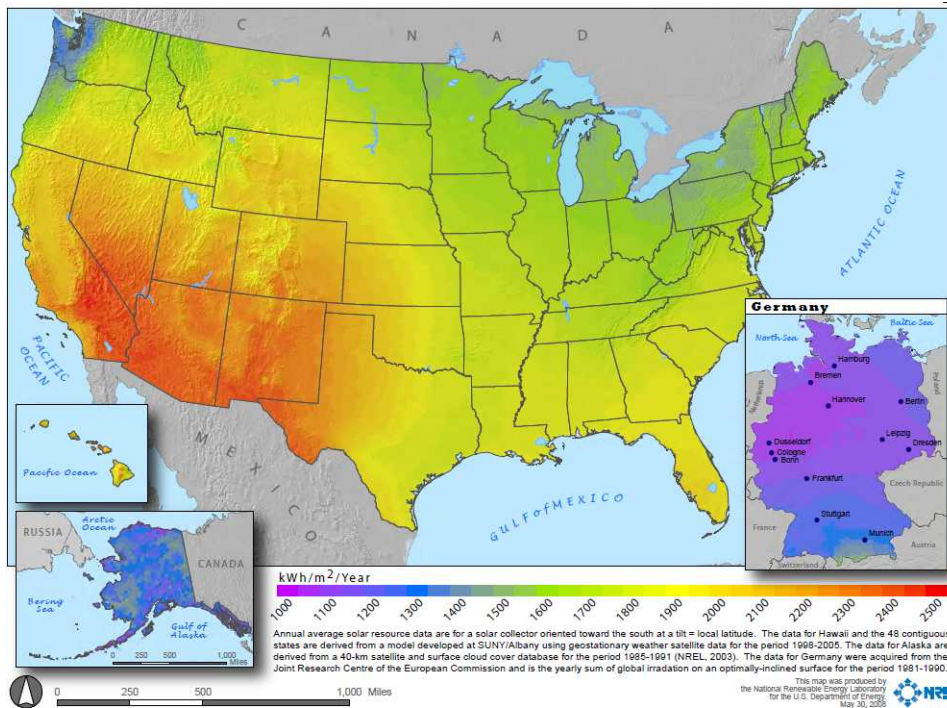

Grid performance requirements

- Voltage & frequency control
- Protection
 - How to tell when/where there is a problem (e.g., fault)
 - Ensure safety, prevent damage to equipment, avoid cascading
- System stability
 - How voltage and frequency recover from a disturbance
- Continuity of service
 - Benchmark: 1-day cumulative outage per customer in a 10-year span (99.97% reliable)

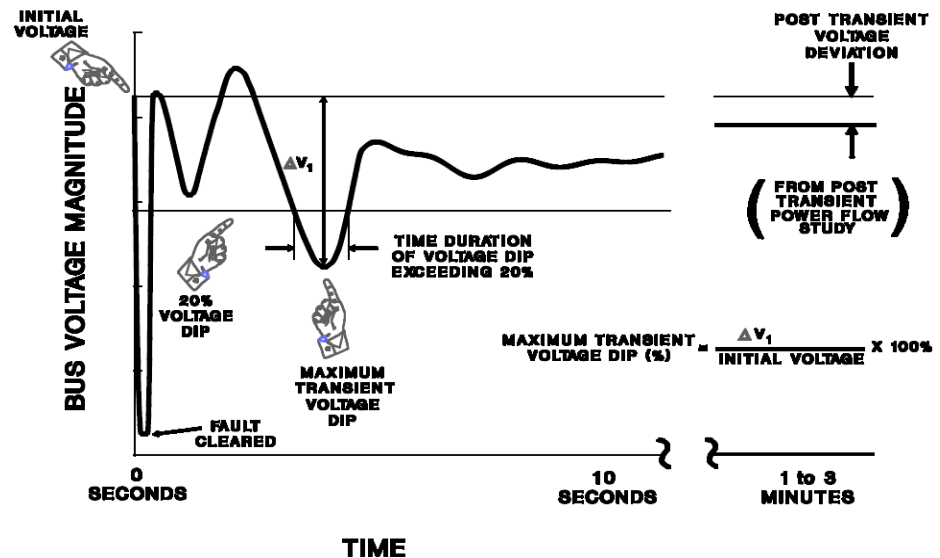
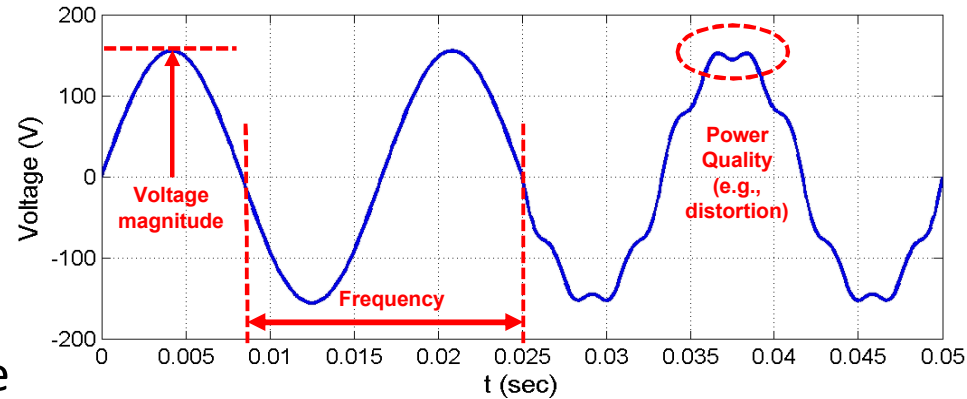

High-Pen PV and grid performance

- PV characteristics (variable, non-dispatchable, inverter-based, distributed) can affect grid performance
 - Local voltage control & protection issues tend to emerge first

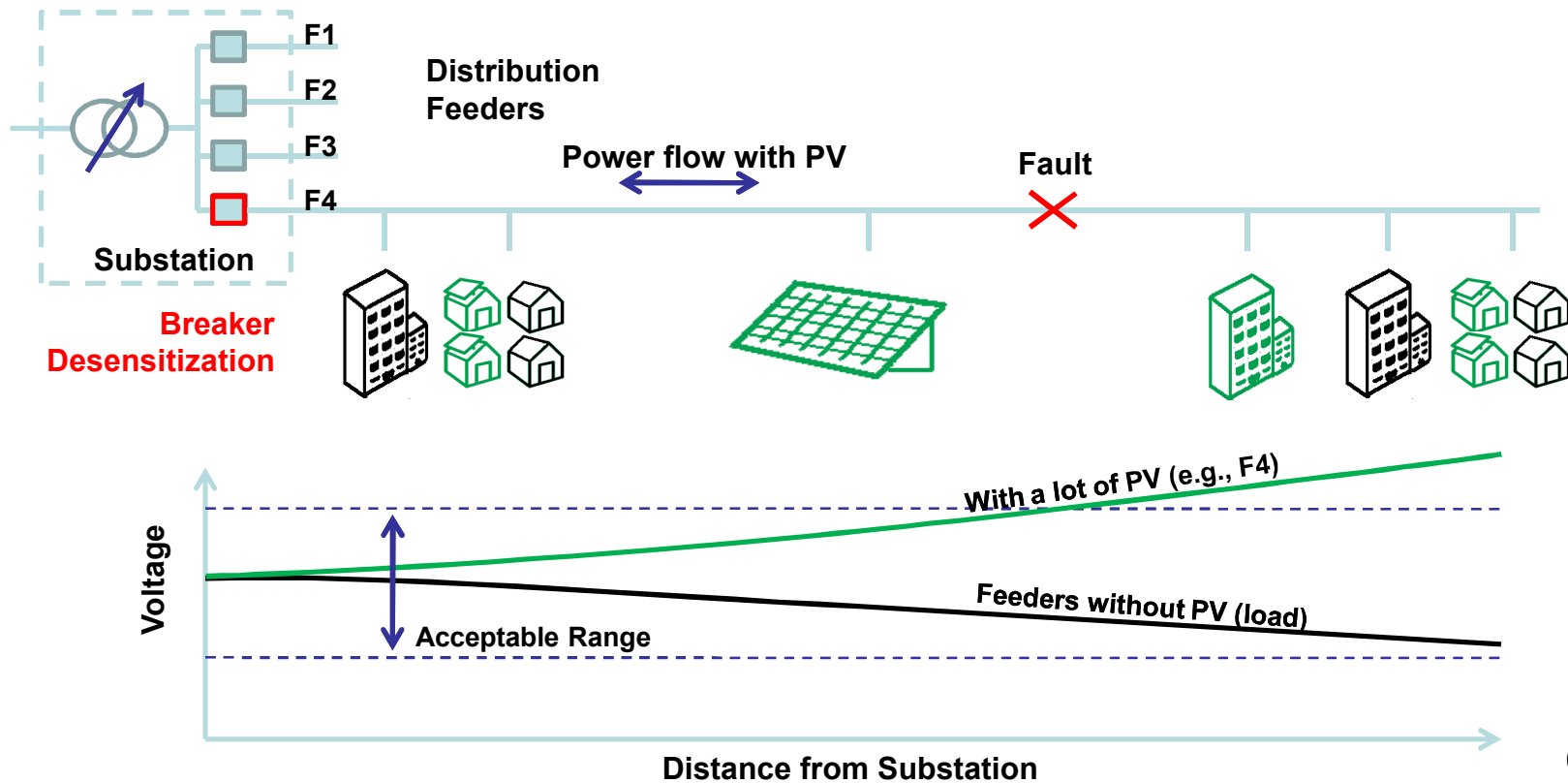

Grid integration challenge

- It can become increasingly difficult and expensive to integrate high-pen PV [3-6]
- A big part of the solution: deployment of advanced inverters in future distribution-connected PV systems [7-8]
 - Mitigate high-pen impacts and enhance value of PV to owner and grid
- Definition [8-9]: Advanced inverters...
 - Actively support voltage and frequency by modulating the output
 - Have high tolerance to grid disturbances
 - Interact with the system via communications



...Faster than a tap changer

...More powerful than a rotating machine

...Able to leap deep voltage sags in a single bound

Courtesy of B. Lydic, Fronius

Advanced inverters

- Advanced inverters allow for higher PV penetration
 - It has been shown that PV inverters with Volt/Var capability can double a distribution circuit's PV hosting capacity (see illustration below) [10]
 - Voltage and frequency ride-through (V/FRT) capability is required to maintain bulk system reliability with high penetration PV [11]

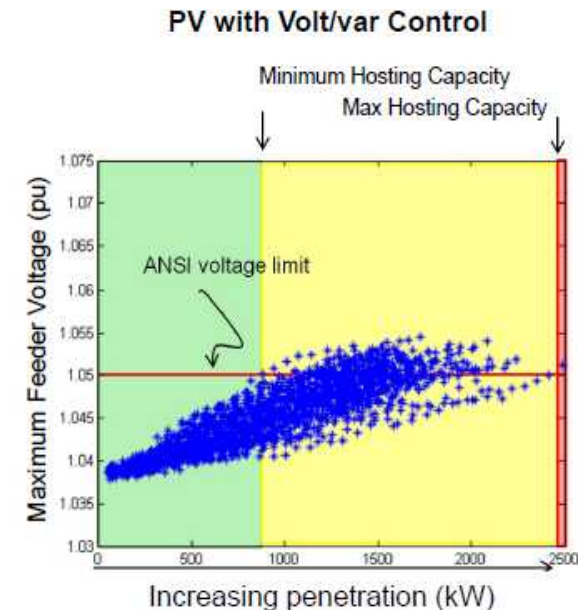
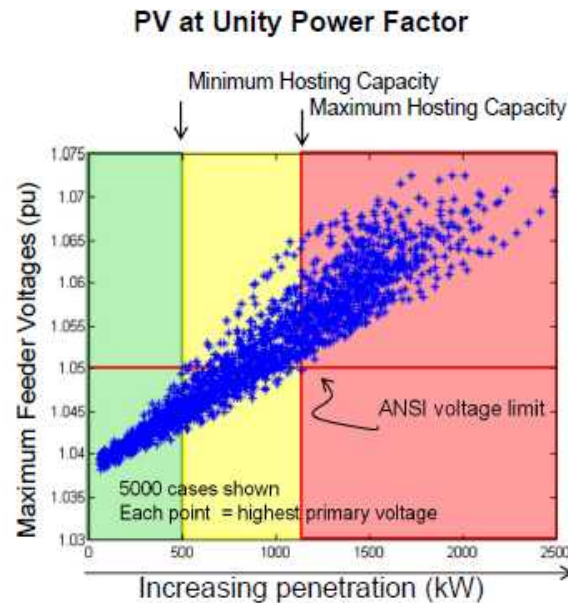
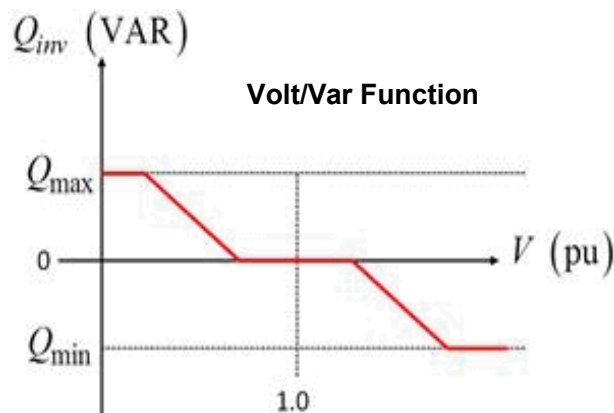

➤ Sandia collaborates with EPRI and NREL to analyze the benefits of advanced inverters in California

Illustration courtesy of B. Seal, EPRI [10]

Functional definitions

- Define functions (e.g., Q vs. V) and how they are specified
- Describe how the functions are implemented [8-9, 12]
 - Autonomous: Inverter response to local voltage and frequency conditions
 - Commanded: Remote control (e.g., on/off) & configure autonomous behavior

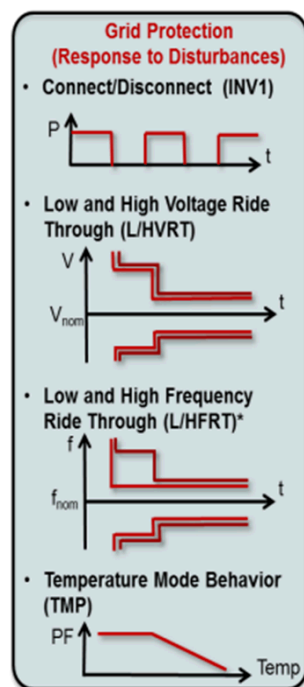
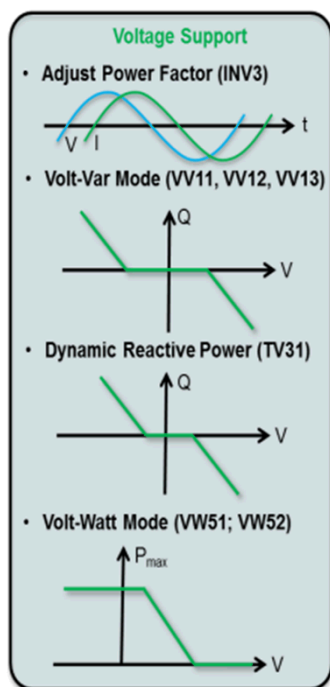
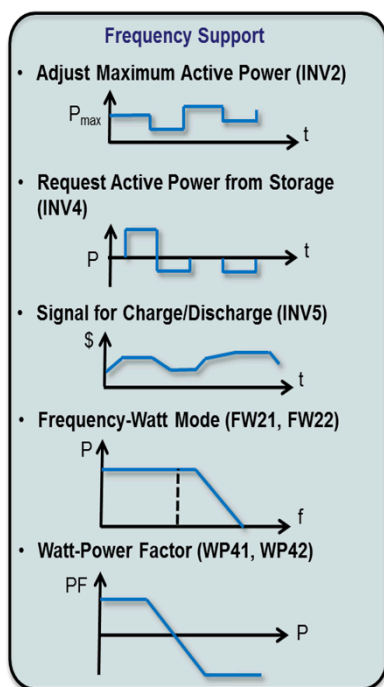

- In 2009, EPRI and Sandia initiated an effort to develop industry consensus on advanced inverter functions definitions, part of SEGIS effort
- Effort covers inverter-based DER (including PV and storage)
- The product became part of the IEC 61850-90-7 technical report

Advanced functions as defined in IEC TC 61850-90-7 [7].

Smart Electricity Grid

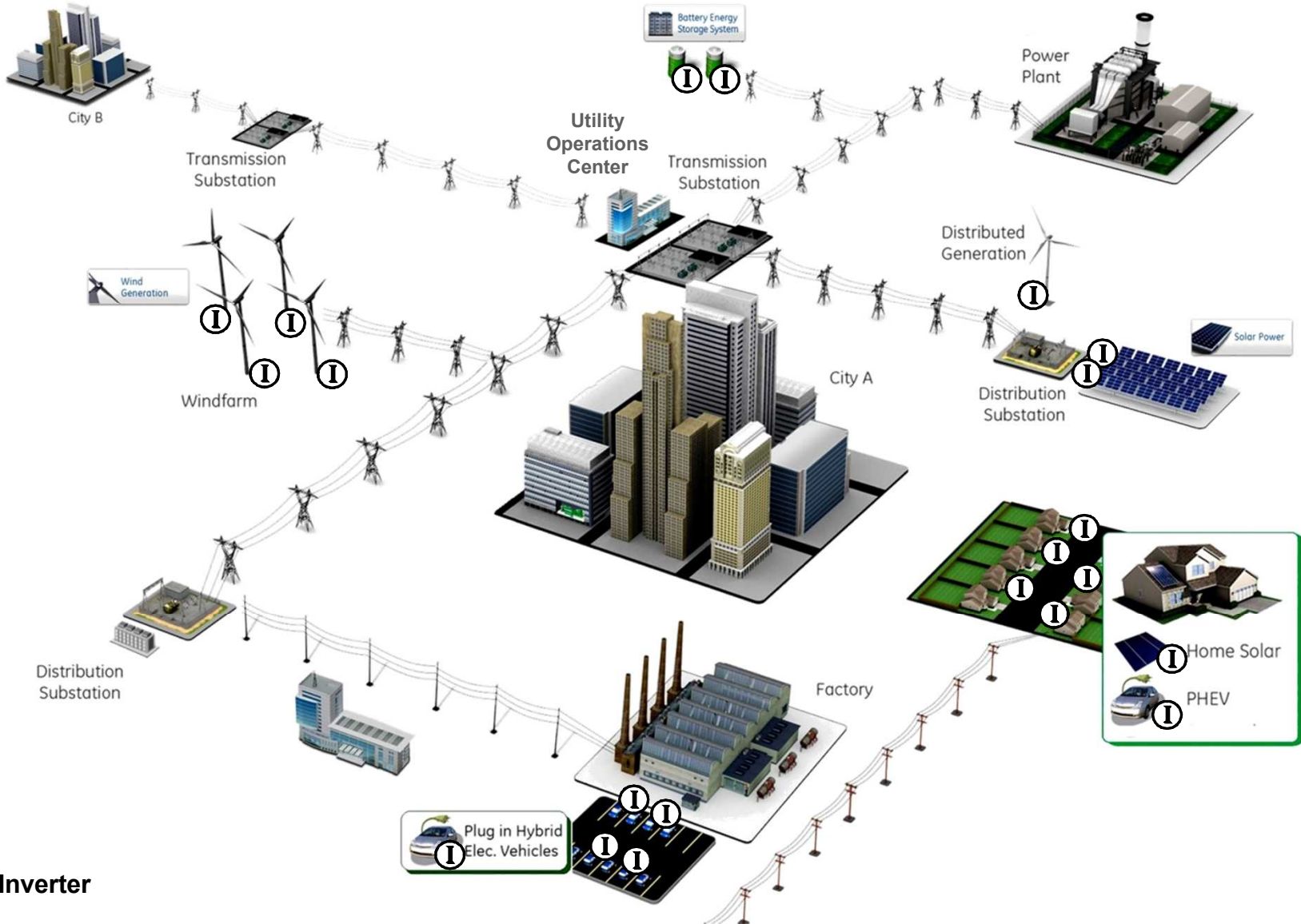

Smart Electricity Grid Communications

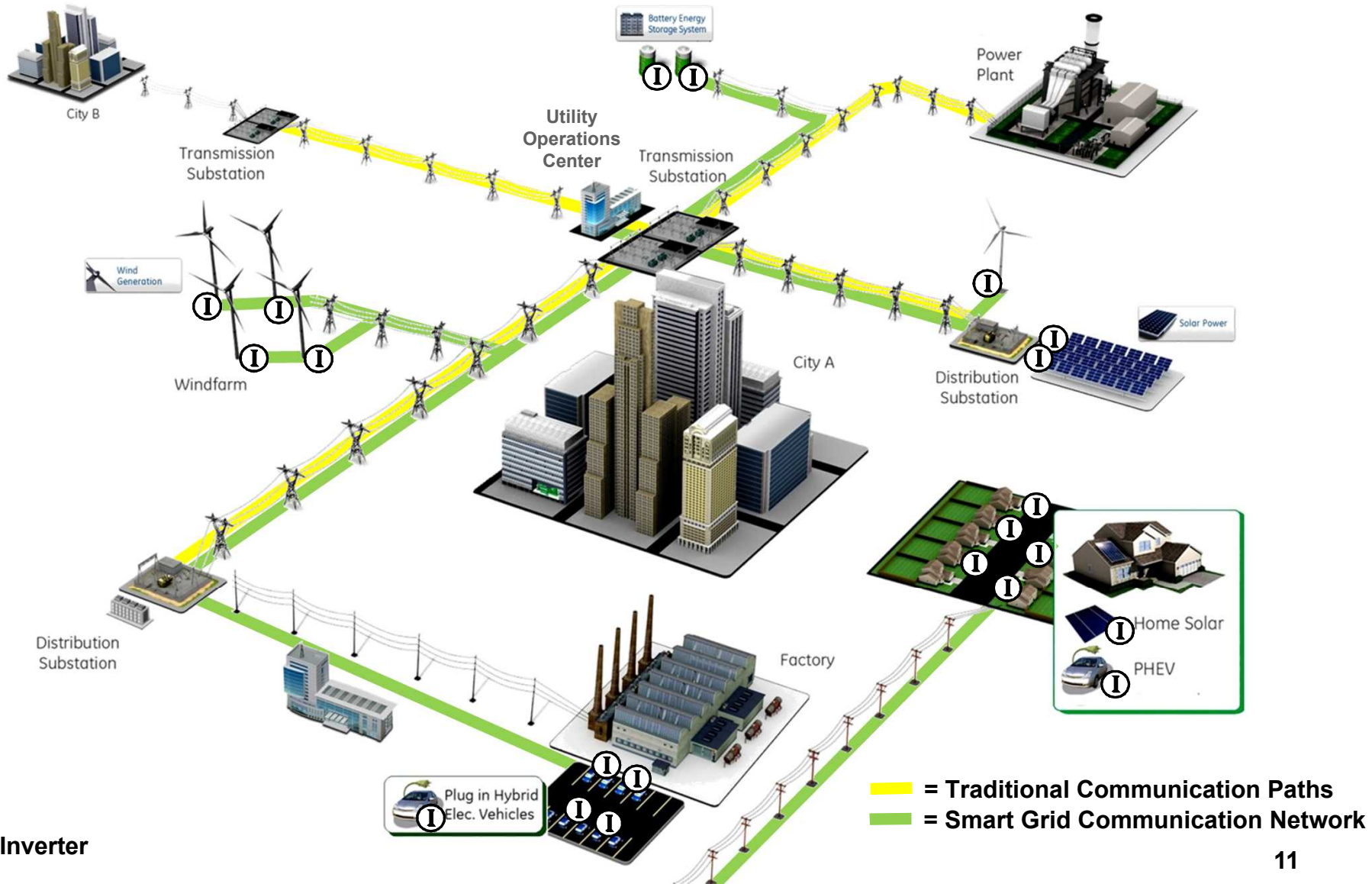

Smart Electricity Grid Communications

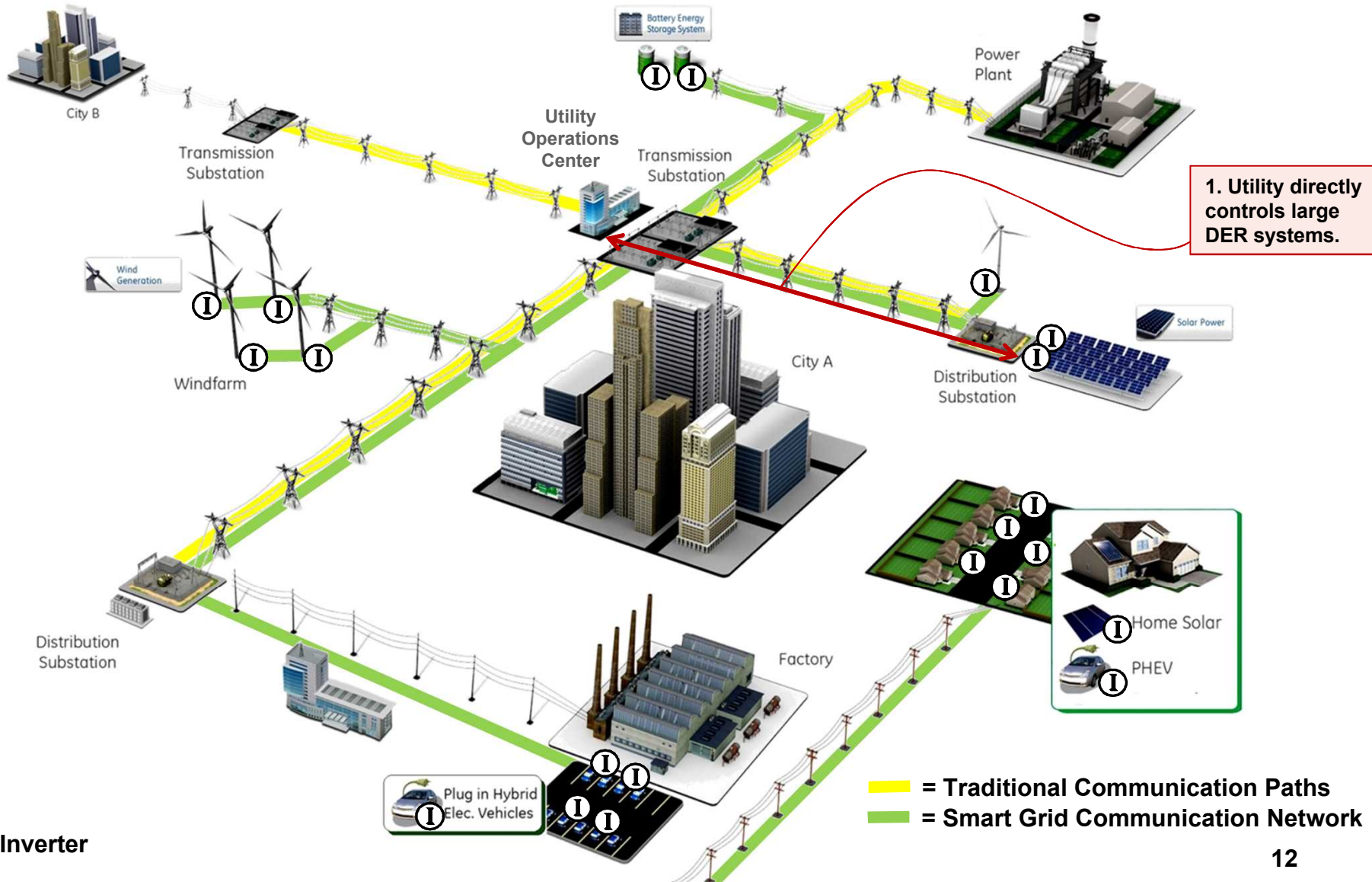

Smart Electricity Grid Communications

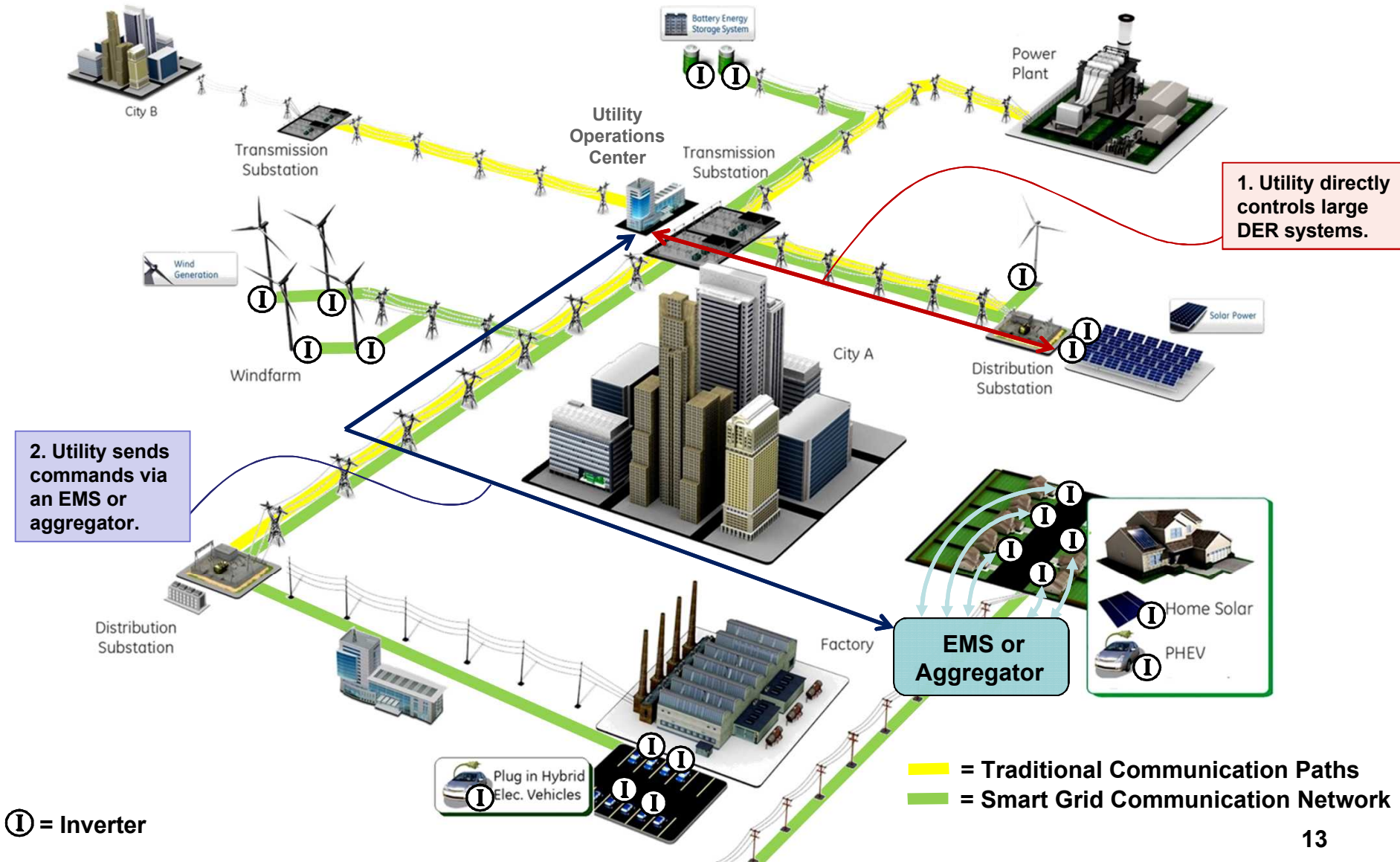

Smart Electricity Grid Communications

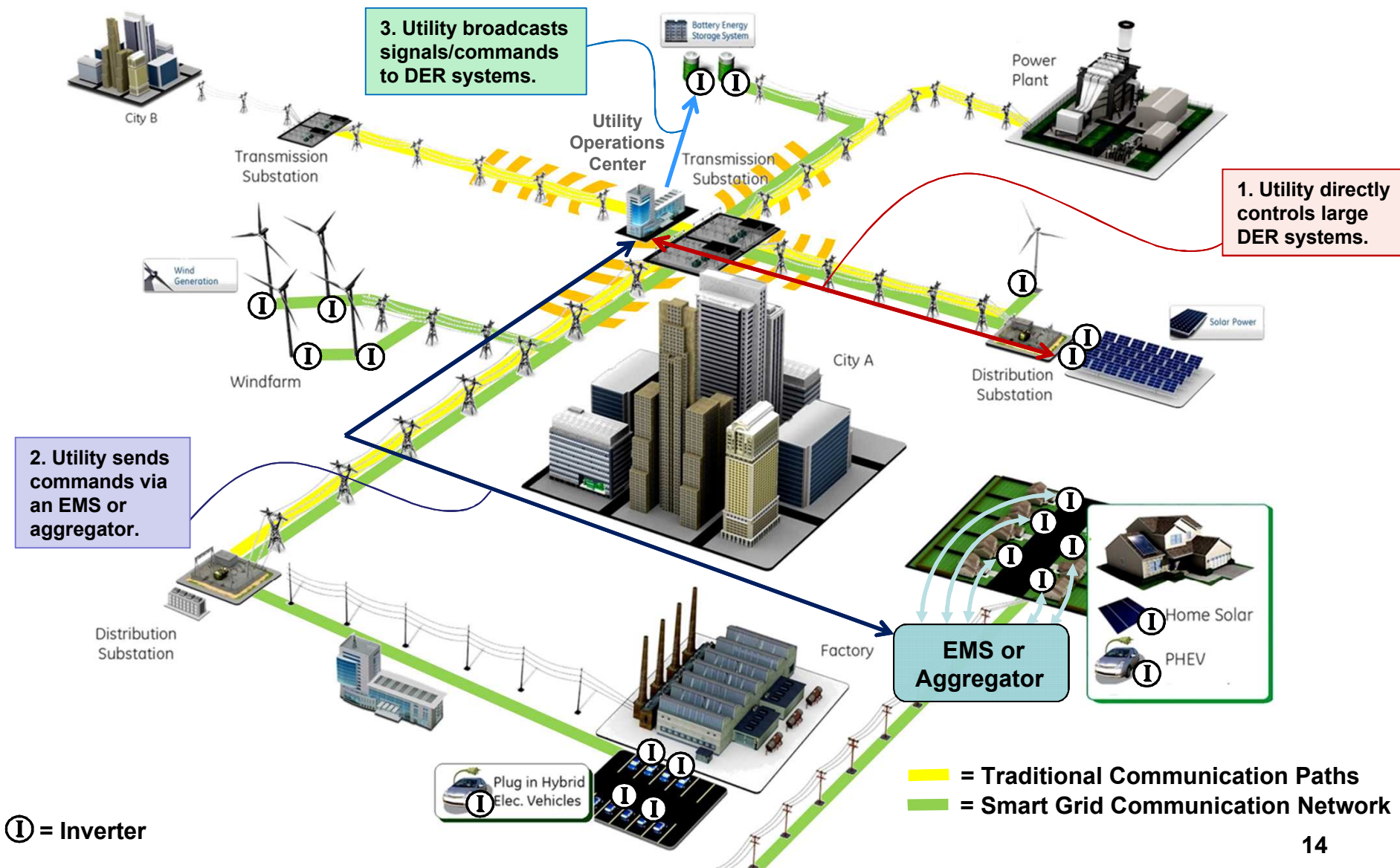

Communications/control architecture

- How will utility, aggregators, smart inverters interact?
- Competing communications solutions
 - Protocols: DNP3, SEP 2.0, IEC 61850, Modbus, OpenADR, SunSpec
 - Medium: Wi-Fi, PLC, Ethernet
 - Method: direct, broadcast

- Open challenges
 - Interoperability
 - Cybersecurity
 - Optimization
 - Utility Integration

➤ Sandia is collaborating with key stakeholders, including NIST, to address interoperability and cybersecurity gaps.

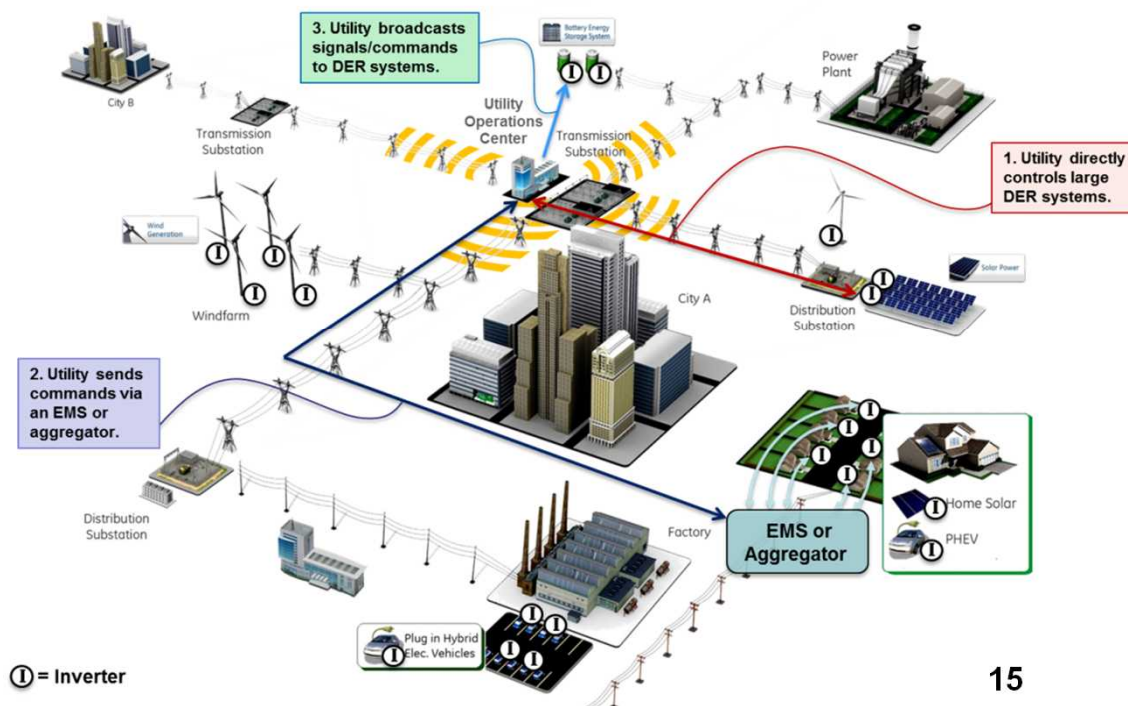

Adv. functions vs. Interconnection Stds.

- IEEE Std. 1547 is the US-wide Distributed Resource (DR) technical standard

DER must not participate in V/f regulation (“get out of the way”) when there are grid disturbances.

IEEE 1547-2008	IEEE 1547a-2014
Shall not regulate voltage [no volt/var allowed]	May participate in voltage regulation [no specification]
Shall not regulate frequency [no freq/watt allowed]	May participate in frequency regulation [no specification]
Restrictive voltage and frequency must-trip range [opposite of V/FRT]	More widely adjustable voltage and frequency must-trip range [No V/FRT requirement]

DER may assist with voltage and frequency regulation with Electric Power System Operator approval.

- Opens the door for jurisdictions to create different interconnection requirements
 - Will likely lead to lack of harmonization and over-specification
 - CPUC Electric Rule 21, PJM, HECO, others starting to develop standards addressing advanced functions

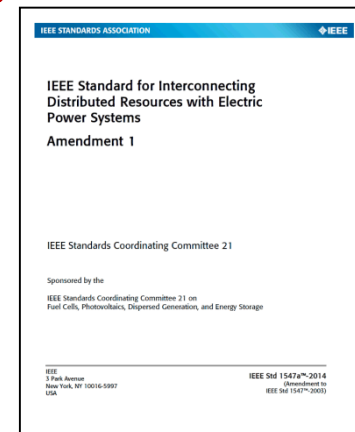

Smart Inverter Requirements in USA

California Investor-Owned Utilities (IOUs):
 Pacific Gas and Electric (PG&E)
 Southern California Edison (SCE)
 San Diego Gas & Electric (SDG&E)



- Serve ~68% of the load in CA
- Governed by California Public Utilities Commission (CPUC) and California Energy Commission (CEC) Electric Rule 21 statute which states the technical requirements for distributed-generation resources to interconnect to the California grid
- Likely to include MANY autonomous and communication-enabled advanced grid functions in the next 1-3 years

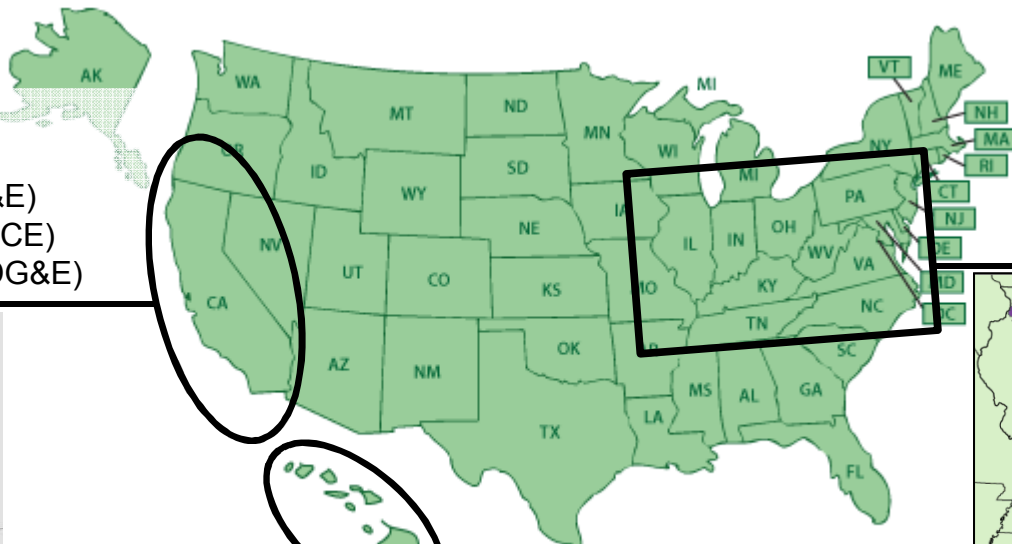

PJM Interconnection LLC
 (regional transmission organization)

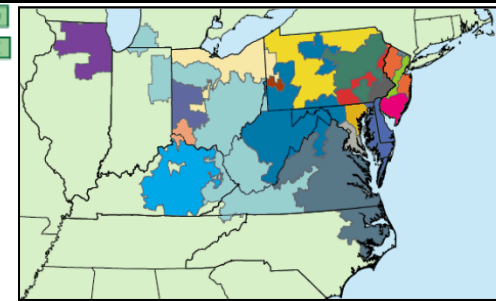

Hawaiian Electric Company (HECO)

- Serves 95% of the state's 1.4 million residents
- Many customers cannot connect their PV systems to the grid because the penetration levels are >100%*
- HECO investigating advanced functions in PV inverters, communications, and mandatory voltage and frequency ride-through requirements

- World's largest competitive wholesale electricity market
- 830 companies
- 60 million customers
- 167 gigawatts of generating capacity
- Closely watching CA developments in Smart Inverters – expected to adopt many of the same interconnection requirements

All eyes on CA right now.

CA CPUC Rule 21 Status

- Jan, 2014: Smart Inverter Working Group (SIWG) consisting of ~150 experts from gov., utilities, PV manufacturers, etc. created “Recommendations for Updating the Technical Requirements For Inverters in Distributed Energy Resources”
 - **Phase 1: Autonomous functions**, ride-throughs, ramp rates, volt/var, etc.
 - **Phase 2: Include communication capabilities**, add data model, cybersecurity, etc.
 - **Phase 3: Add advanced inverter functionalities requiring communications**, status reporting, connect/disconnect, limit real power, etc.
- July 18, 2014: Joint motion from the 3 IOUs is sent to the CPUC to add the following advanced functions:
 - Anti-islanding – default status: activated
 - Low/High Voltage Ride-Through – default status: activated
 - Low/High Frequency Ride-Through – default status: activated
 - Dynamic Volt/Var operations – default status: deactivated
 - Ramp rates – default status: activated
 - Fixed power factor – default status: activated
 - Reconnect by “soft-start” methods – default status: activated

Development of Rule 21 Certification Procedures

- Sandia is helping develop the **certification procedures** for the Rule 21 functions with two groups:
 - UL 1741 Standards Technical Panel working groups
 - EPRI-operated California Solar Initiative Project
- Protocols are different than the original Sandia Test Protocols for IEC 61850-90-7 because they have strict pass/fail criteria

Function	Function or Communication Verification	
1	Anti-Islanding Protection (AI)	Phase 1
2	Low/High Voltage Ride-through (L/HVRT)	
3	Low/High Frequency Ride-through (L/HFRT)	
4	Volt-Var Mode with Watt-Priority	
5	Ramp Rates	
6	Fixed Power Factor	
7	Soft Start	
8	Communication Interface	Phase 2
9	Transport Protocols	
10	Data Model	
11	Mapping to Application Protocols	
12	Transport Cyber Security	
13	User Cyber Security	
14	Monitor Alarms	
15	Monitor DER Status and Output	Phase 3
16	Limit Maximum Real Power	
17	Connect/Disconnect	
18	Provide DER Information at Interconnection/Startup	
19	Initiate Periodic Tests of Software and Patches	
20	Schedule Output Limits at PCC	
21	Schedule DER Functions	
22	Schedule Storage	
23	Frequency-Watt Mode	
24	Voltage-Watt Mode	
25	Dynamic Current Support	
26	Limit Maximum Real Power	
27	Set Real Power	
28	Smooth Frequency Deviations	

Rule 21 advanced inverter/DER functions,
as recommended by the Smart Inverter
Working Group in Jan 2014

Communication Requirements for Rule 21

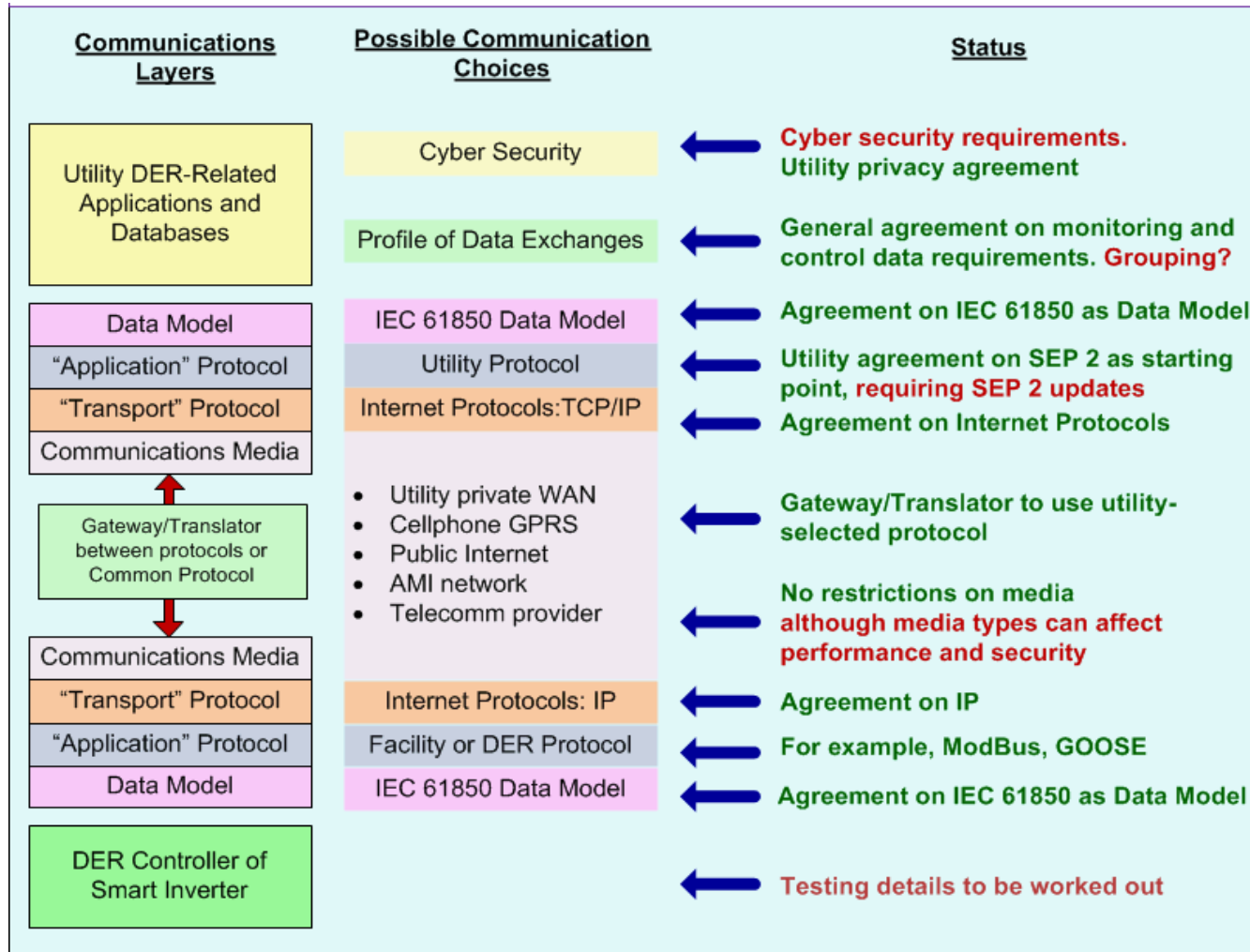

From Oct 30, 2014 SIWG meeting, courtesy of Frances Cleveland, Xanthus Consulting International

DER Configurations, SEP2, and Other Protocols

Smart Energy Profile (SEP 2) as Communications Protocol between Utilities and other Parties

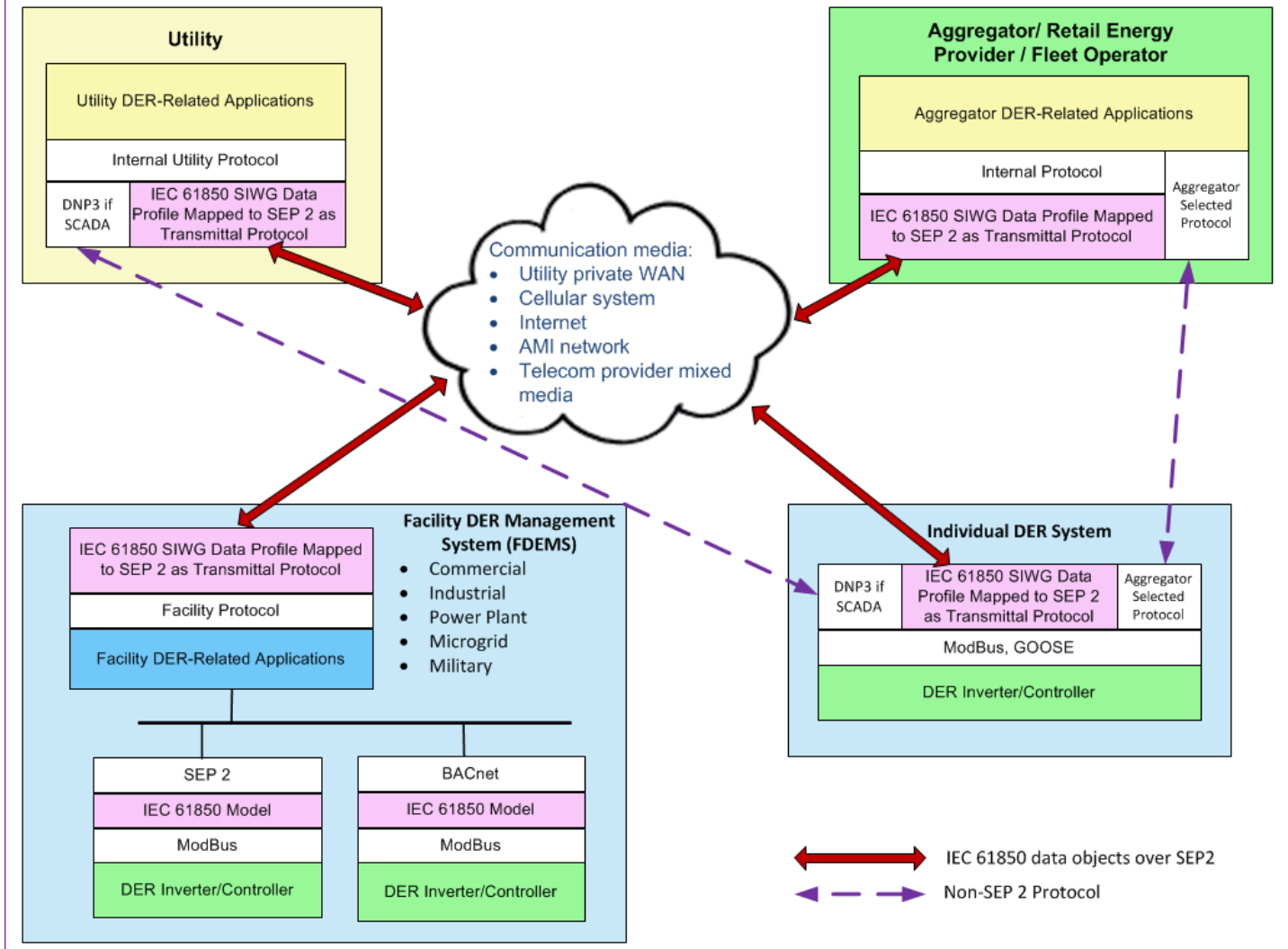

From Oct 30, 2014 SIWG meeting, courtesy of Frances Cleveland, Xanthus Consulting International

Cybersecurity - Many unanswered questions!

- What are the utility **security policies** for interacting with non-utility sites and equipment where the data to be exchange has operational impacts?
- What utility **security procedures** must be followed by such non-utility sites in order for operational data to be exchanged? In particular, how can new DER sites be "registered" and tested for security compliance?
- Are there **different security requirements** for different types of sites, e.g. small < 10 MW DER sites versus > 10 MW sites? Short versus long sessions? VPN for larger sites?
- Have utility security policies and procedures been **clearly established** or are they still being worked on for interactions with DER systems?
- Are there specific **security technologies** that must be used? Are there specific technologies that must not be used?
- Some security technologies are specific to **different communication protocols** - are there preferred protocols (e.g. IPsec, TLS, PKI) from a security perspective?
- Is there agreement that at least **authentication** and **data integrity** must be ensured? When should **non-repudiation / accountability** be ensured?
- When should **confidentiality** be ensured?
- **Application-to-application** security?
- How is **key management** expected to be handled, including session key management? PKI? What Certificate Authorities can/must be used?
- Will **Role-based Access Control (RBAC)** be used to constrain the permitted actions?
- Are these cyber security requirements **accepted by all California utilities** or are there major differences?
- What **other cyber security issues** need to be resolved? Impact of cyber security on performance

Collaborative Research at Sandia National Laboratories

Grid integration pre-standardization research with EPRI

- Sandia collaborating with EPRI on “Standard Communication Interface and Certification Test Program for Smart Inverters”
 - Partly funded by the California Solar Initiative (Grant 4)
- Sandia leading development of inverter test procedures – harmonized with UL 1741 STP working groups for the new functions



SunSpec Modbus + CEA-2045*

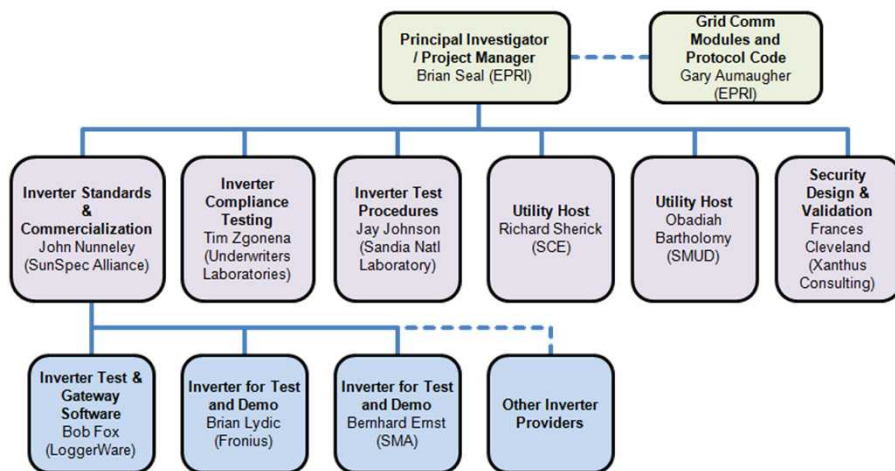

Function	Function or Communication Verification
1	Anti-Islanding Protection (AI)
2	Low/High Voltage Ride-through (L/HVRT)
3	Low/High Frequency Ride-through (L/HFRT)
4	Volt-Var Mode with Watt-Priority
5	Ramp Rates
6	Fixed Power Factor
7	Soft Start
8	Communication Interface
9	Transport Protocols
10	Data Model
11	Mapping to Application Protocols
12	Transport Cyber Security
13	User Cyber Security
14	Monitor Alarms
15	Monitor DER Status and Output
16	Limit Maximum Real Power
17	Connect/Disconnect
18	Provide DER Information at Interconnection/Startup
19	Initiate Periodic Tests of Software and Patches
20	Schedule Output Limits at PCC
21	Schedule DER Functions
22	Schedule Storage
23	Frequency-Watt Mode
24	Voltage-Watt Mode
25	Dynamic Current Support
26	Limit Maximum Real Power
27	Set Real Power
28	Smooth Frequency Deviations

Rule 21 Advanced Inverter/DER Functions

SIRFN Smart Grid Collaboration



- **Primary goal:** Develop and demonstrate a consensus-based interoperability certification standard for IEC 61850-90-7 advanced Distributed Energy Resources (DERs).
 - Design and compare advanced interoperability test-beds.
 - Perform round-robin testing of advanced DER.
 - Compare test results, communications methods, and automation procedures.
 - Gradually improve draft test procedures for advanced DER with the goal of becoming an internationally-accepted standard.

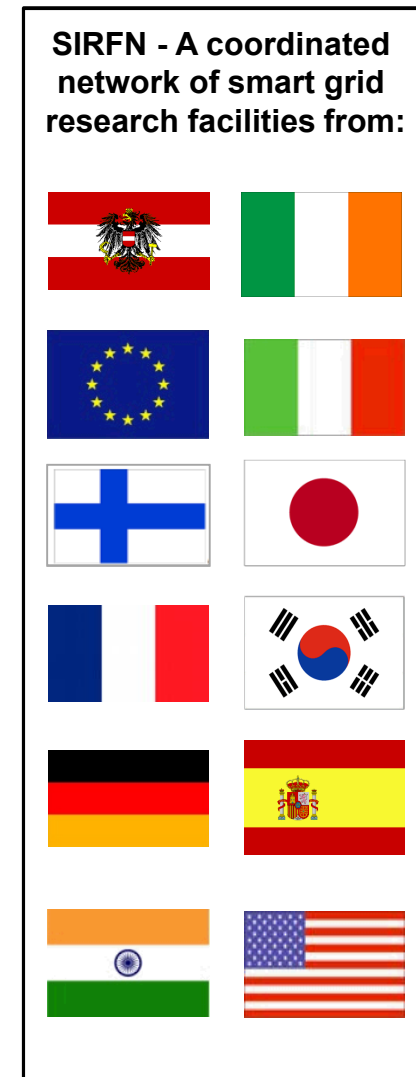

Importance of SIRFN Collaboration

- **SIRFN collaboration on testing standards is important to accelerate the deployment of renewable energy around the world.**
 - **Urgency in U.S. to certify inverters for new requirements** – both electrical performance and communications
 - Need advanced inverter test protocols for CPUC/CEC California Rule 21
 - Sandia protocols act as basis for updates to UL 1741
 - **Final product:** robust consensus certification procedure for advanced inverter functions for adoption by international standards organizations
 - *Note: this is similar to another Sandia project with the Korea Electrotechnology Research Institute in Changwon, Korea.*



SNL, AIT, and TECNALIA Test-Bed Designs

Sandia National Laboratories

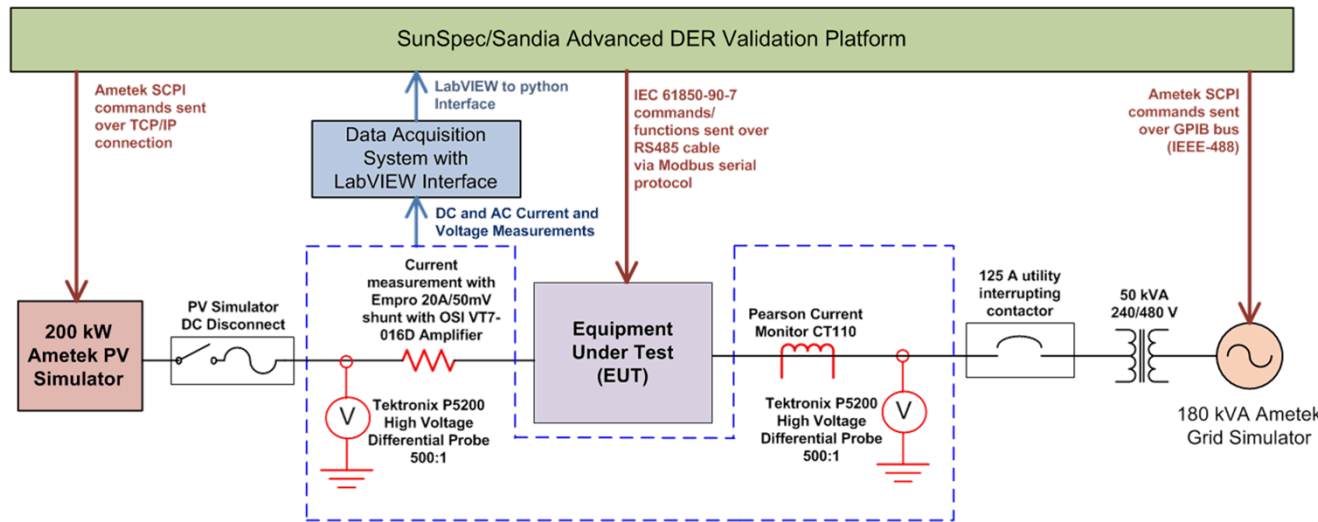

EUTs:

- SNL: 3 kW single-phase inverter
- AIT: 20 kW three-phase inverter
- Tecnalía: 5 kW single-phase inverter

EUT Communications

- SNL: 61850-90-7 over serial
- AIT: 61850-90-7 over TCP
- Tecnalía: 61850-90-7 over serial

Control system

- SNL: SunSpec Test Tool (Python)
- AIT: Lab Control System (Matlab)
- Tecnalía: Master Computer (Python)

Austrian Institute of Technology

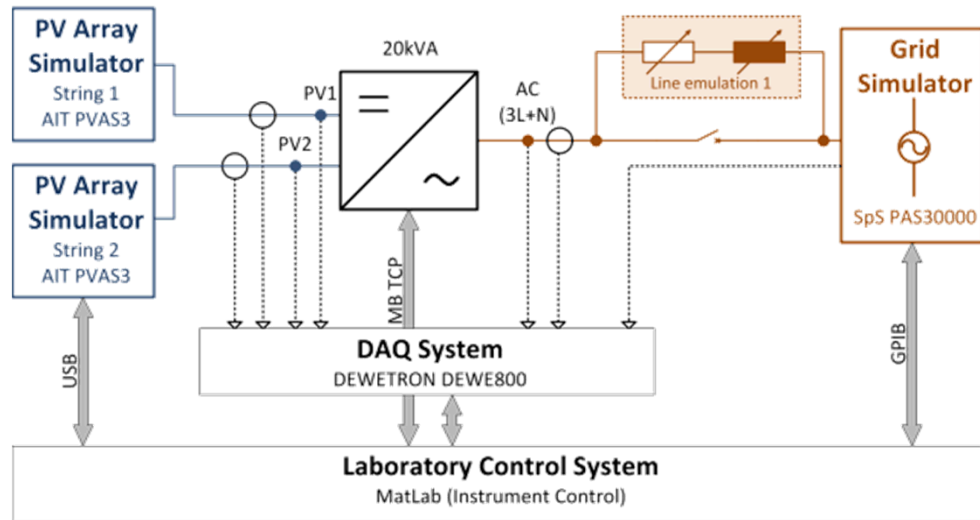

TECNALIA

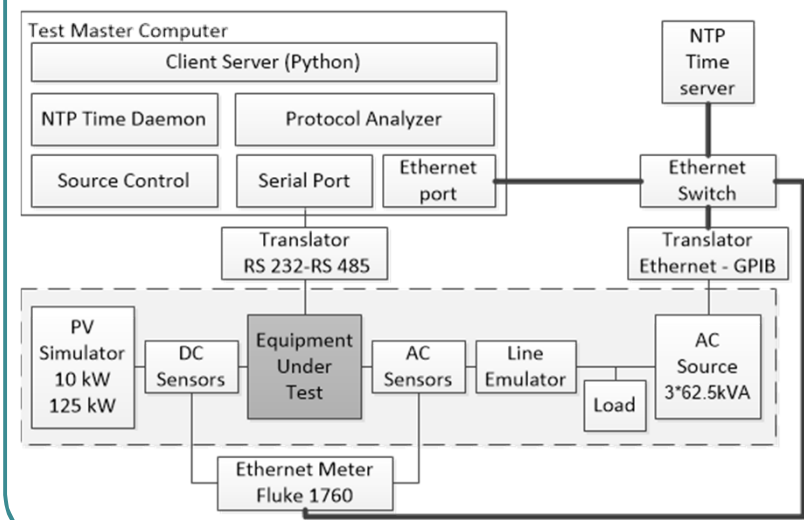

Example Test Protocol (Procedure)

- The Sandia Test Protocols test matrix for the connect/disconnect (INV1) command.
 - Seven tests with different operating points and parameters.



Test	EUT Initial Operating State	Command	Time Window (sec)	Timeout Period (sec)
1	>50% rated power, unity power factor	Disconnect 1	Default (e.g., 0)	Default (e.g., 0)
2	Inverter off	Connect 1	Default (e.g., 0)	Default (e.g., 0)
3	>50% rated power, unity power factor	Disconnect 2	0	Default (e.g., 0)
4	Inverter off	Connect 2	0	Default (e.g., 0)
5	>50% rated power, unity power factor	Disconnect 3	90	30
6	>50% rated power, unity power factor	Disconnect 4	60	0 (No Timeout)
7	Inverter off	Connect 4	60	0 (No Timeout)

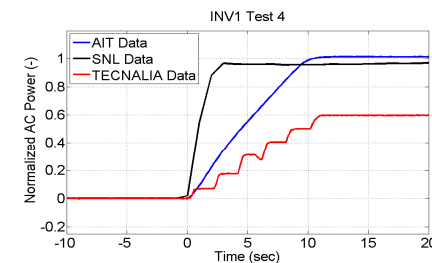
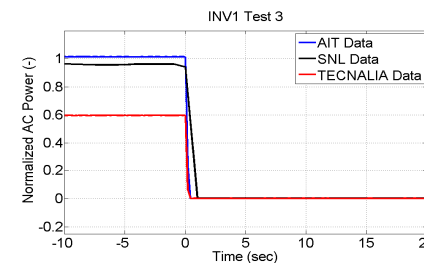
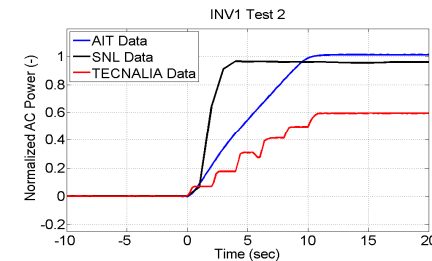
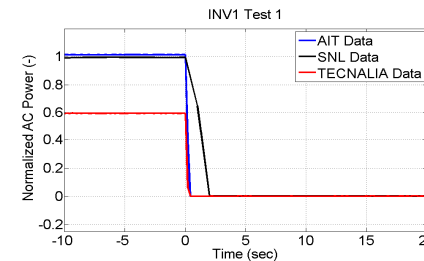

J. Johnson S. Gonzalez, M.E. Ralph, A. Ellis, and R. Broderick, "Test Protocols for Advanced Inverter Interoperability Functions – Appendices," Sandia Technical Report SAND2013-9875, Nov. 2013.

Real Power Curtailment (INV2) Results

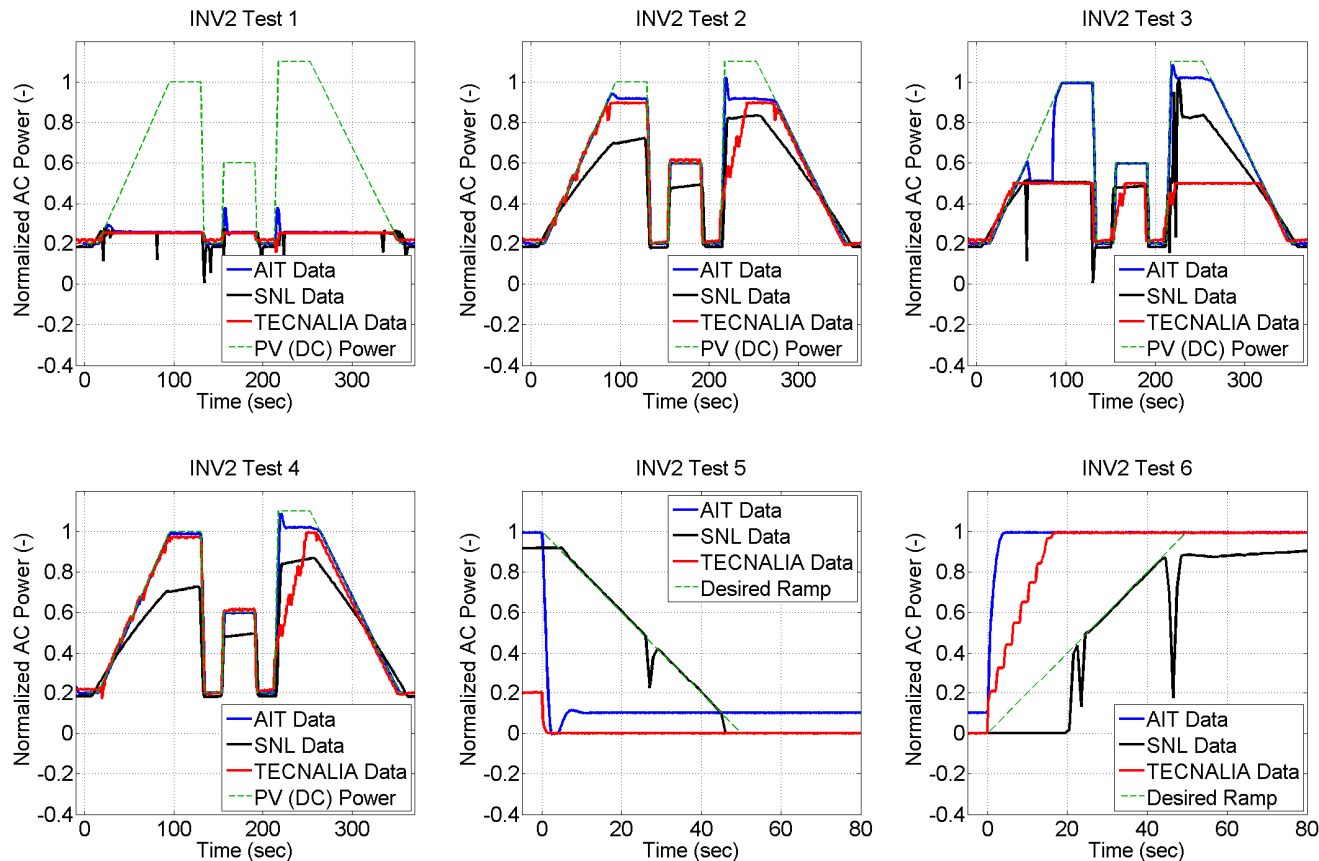

Test	WMax (% nameplate)	Ramp Rate (% nameplate watts/sec)	Time Window (sec)	Timeout Period (sec)	PV Power Profile
1	25	0	0	0	Fig. A2- 1
2	90	0	300	0 AIT:60	Fig. A2- 1
3	50	20	60	30 AIT:60	Fig. A2- 1
4	100	0	0	0	Fig. A2- 1
5	0 AIT:10	2	0	0	Const.
6	100	2	0	0	Const.

Fixed Power Factor (INV3) Results

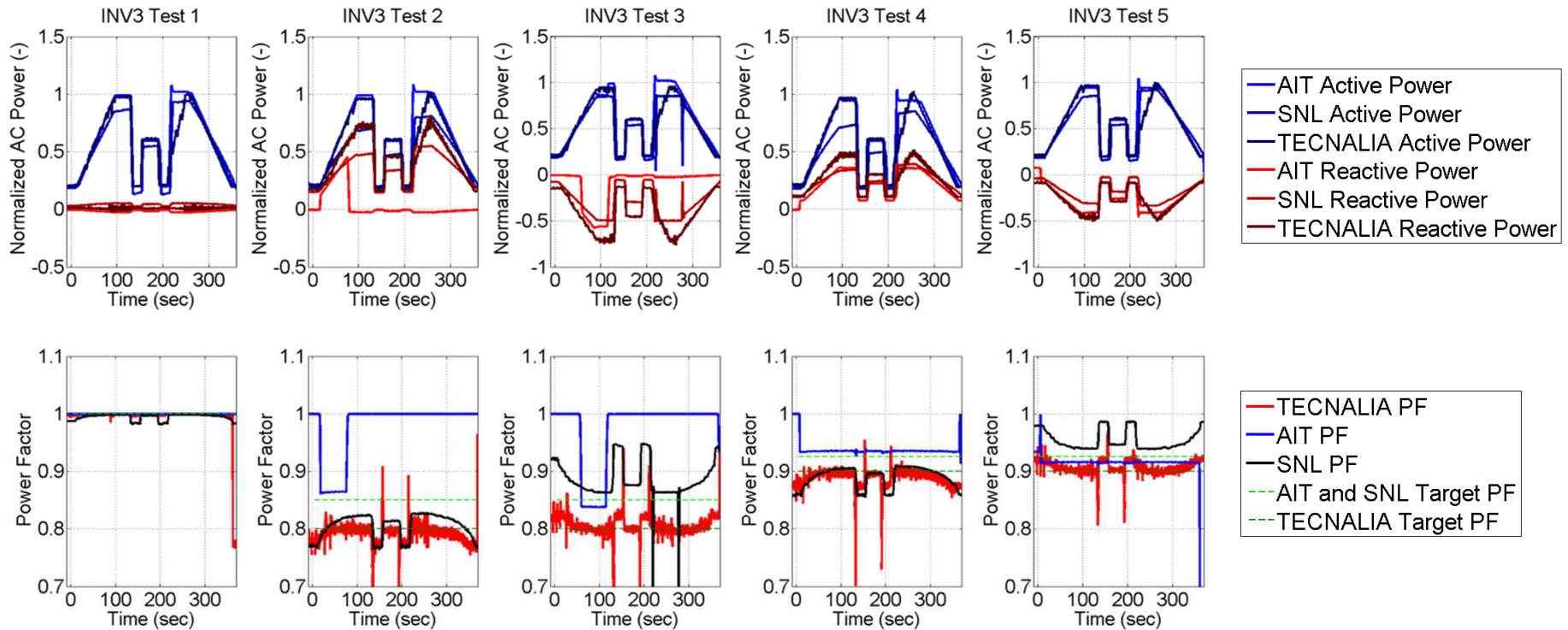

Test	Power Factor (INV3)	Ramp Rate (% nameplate watts/sec)	Time Window (seconds)	Timeout Period (seconds)
1	1.00 (default)	Default	0	Default
2	MinPFOverAval (e.g., 0.80 Overexcited)	Default	60	600
3	MinPFUnderAval (e.g., 0.80 Underexcited)	Default	300	Default
4	0.5+MinPFOverAval/2 (e.g., 0.90 Overexcited)	10	Default	Default
5	0.5+MinPFUnderAval/2 (e.g., 0.90 Underexcited)	Default	Default	1800

Protection Coordination

- Some advanced functions can affect protection coordination
 - One example: Degradation of anti-islanding (AI) performance [13]
 - V/FRT capability can increase run-on times during AI certification test
 - Volt/var and freq/watt functions counter positive feedback AI methods

Anti-islanding certification test circuit

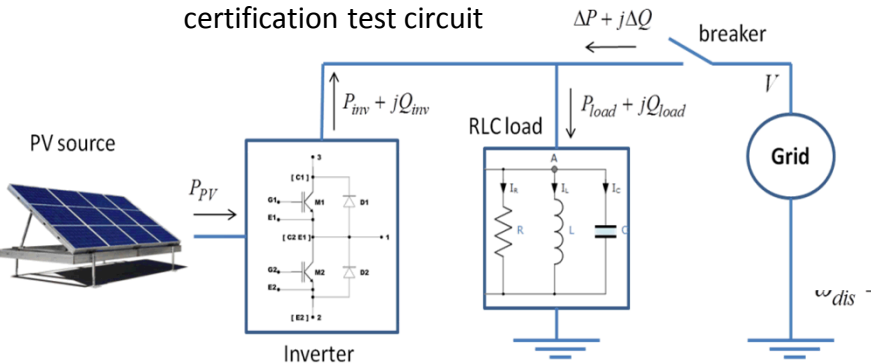

Voltage and frequency after the breaker opens



$$V_{dis} = \sqrt{\frac{P_{inv}}{P_{rated}}} \cdot V_{rated} \quad (1)$$

$$\omega_{dis} = \frac{-\frac{Q_{inv}}{CV_{dis}^2} + \sqrt{\left(\frac{Q_{inv}}{CV_{dis}^2}\right)^2 + \frac{4}{LC}}}{2} \quad (2)$$

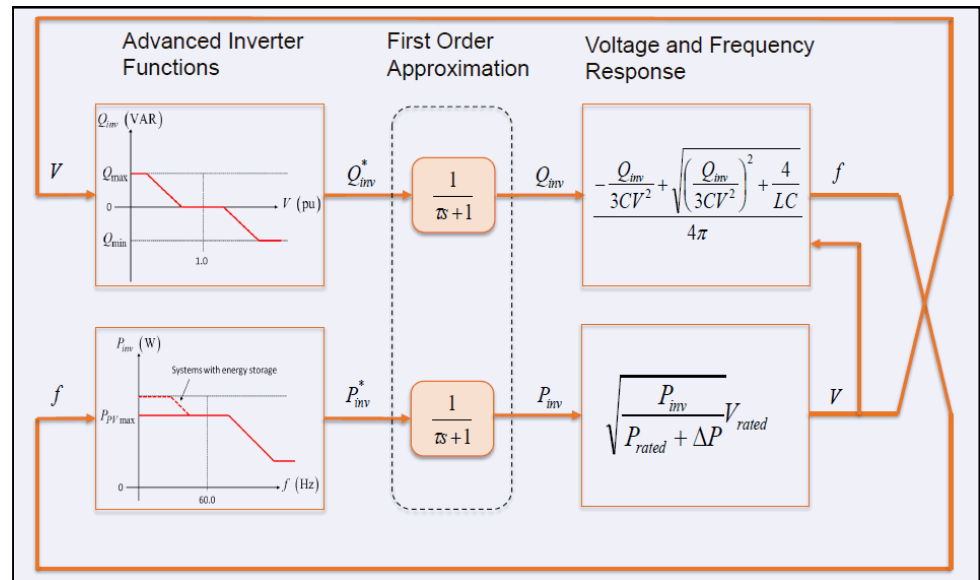

A simple model can be used to show how advanced functions (voltage and frequency support) could affect anti-islanding performance.

Example: anti-Islanding

- Analysis shows that volt/var & freq/watt functions can make certain anti-islanding methods less effective
 - Example below is for a 50 kW inverter using Sandia Frequency Shift AI method
 - AI is more difficult with V/FRT as well!

Without volt/var and freq/watt.

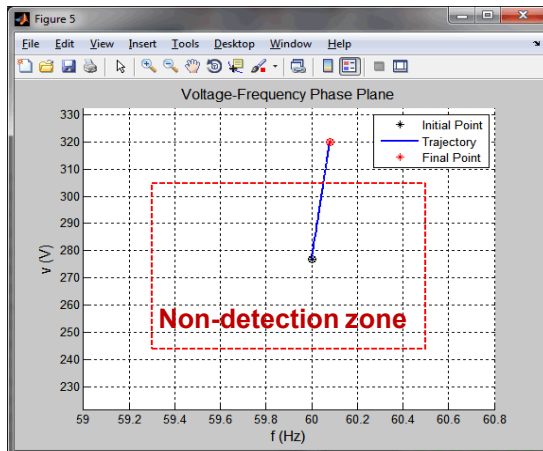

With volt/var and freq/watt.

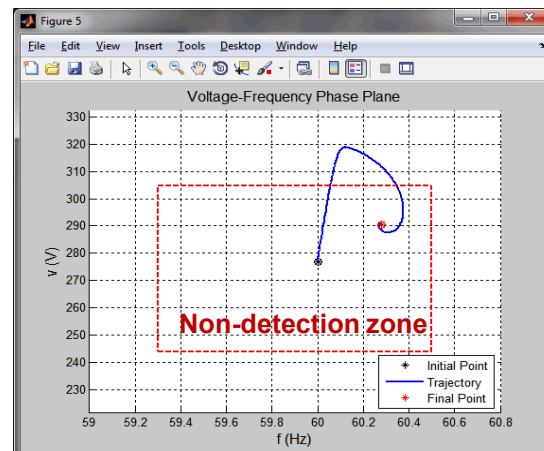

- Sandia is investigating control- and communication-based solutions to this problem
 - Optimization of control parameters (gains and delays) for a given anti-islanding scheme
 - PLC and synchrophasor “heartbeat” methods [14]

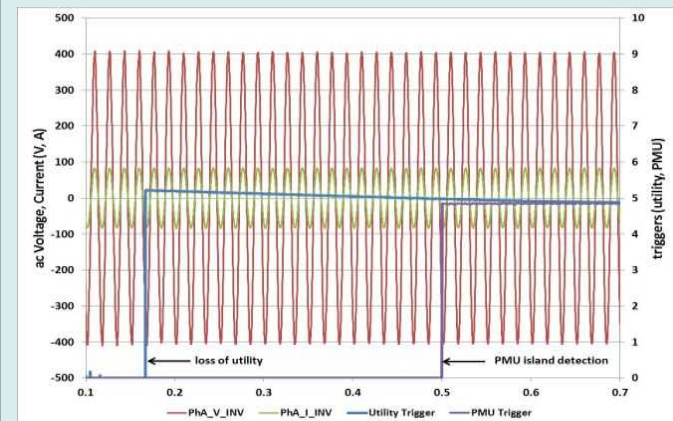

The illustration shows experimental results for a “failed” anti-islanding test conducted at Sandia, and effective synchrophasor islanding detection.

Sandia's Virtual Power Plant Research

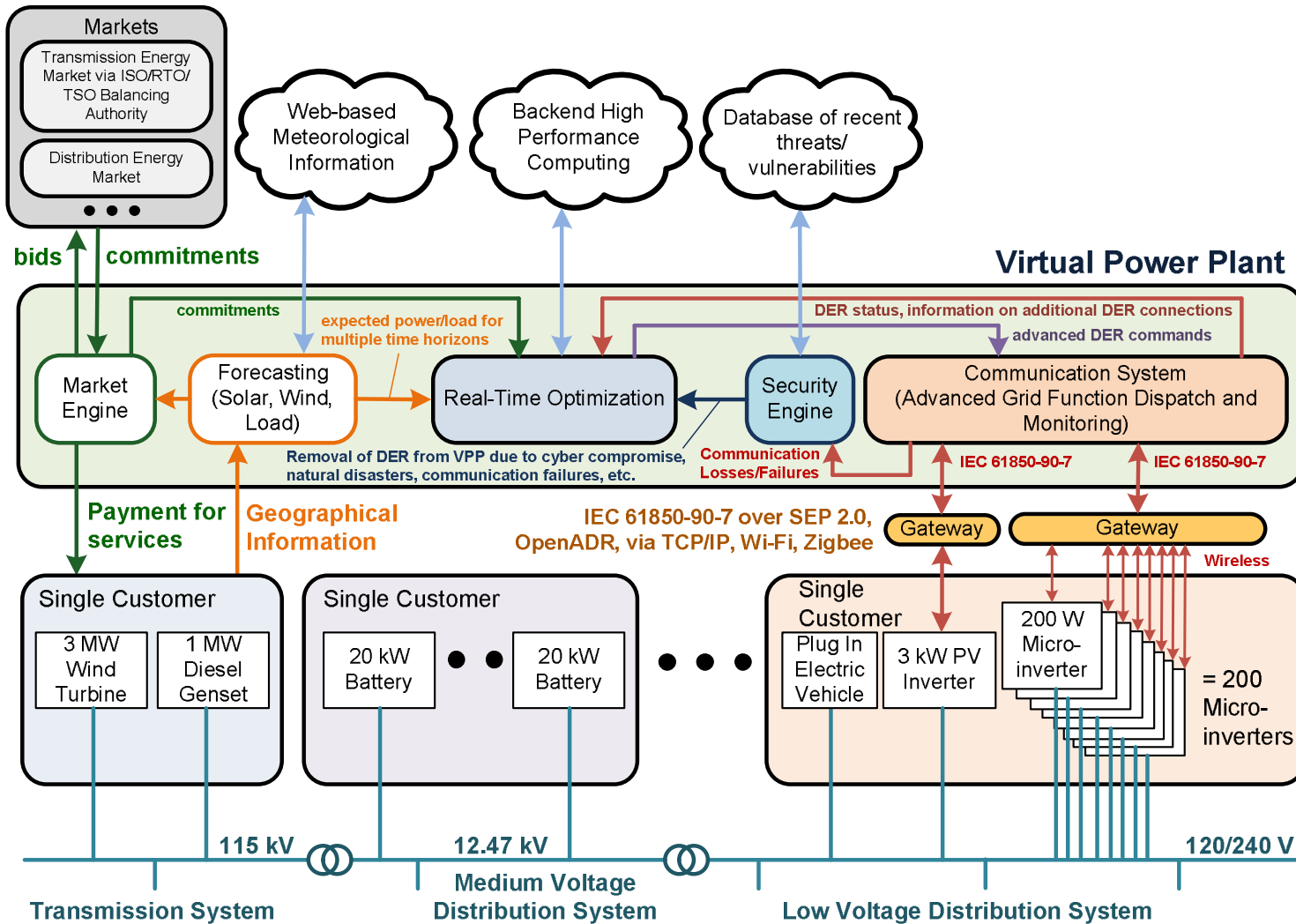

Sandia's VPP Research Testbed

- 13 small DER in the DETL lab (initially) operating on frequency reserve markets
- Data collection is performed with 3 data acquisition systems (DASs)
- Hardware-in-the-loop simulations with amplify the number of devices in the virtual power plant
- Fault scenarios can be performed with the 180 kVA grid simulator

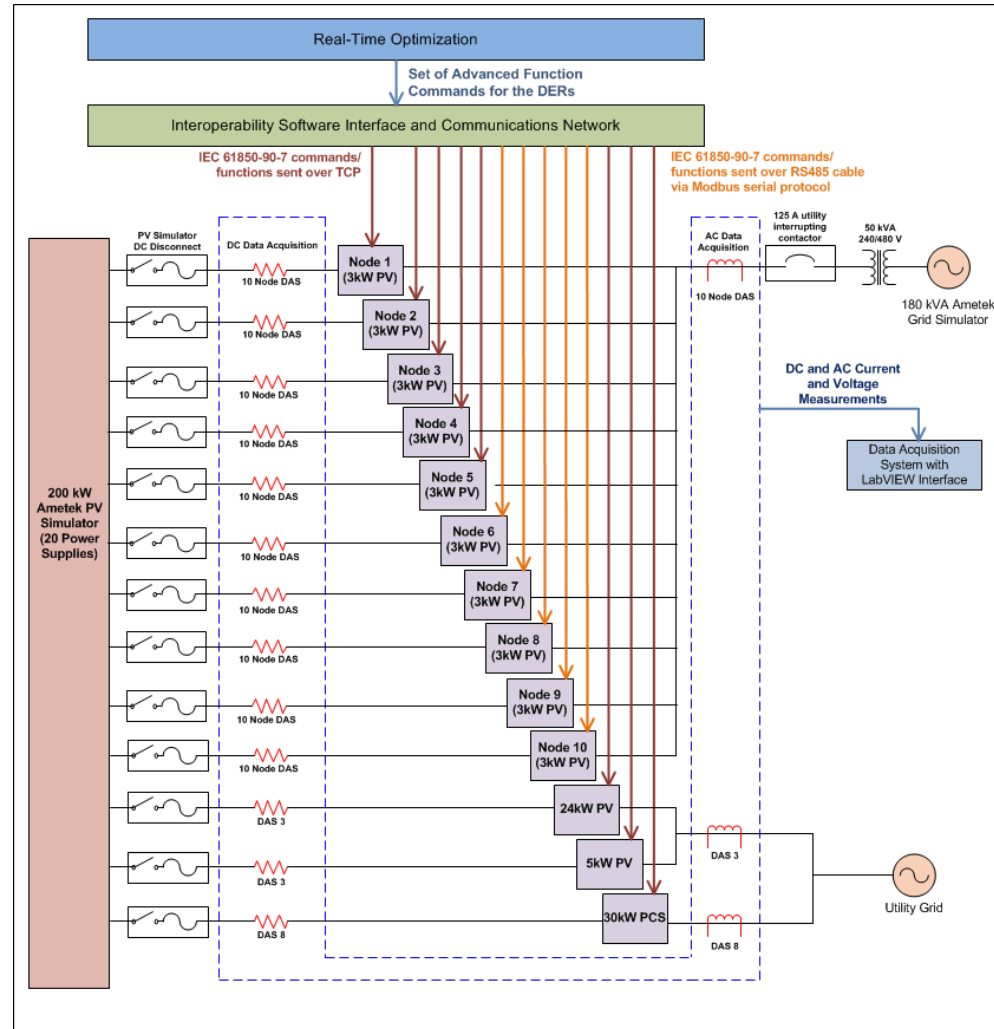

Conclusions

- PV inverters advanced functions help support the grid
- Need a standardized method for verifying DER functionality
- In the U.S. many jurisdictions are considering the implementation of smart inverters
 - Allowed with the adoption of IEEE 1547a
 - Regional differences could be an issue for manufacturers and certification laboratories
 - Autonomous functions will be rolled out first
 - Communications methods are not finalized, cybersecurity a big concern
- Sandia and SIRFN are improving certification protocols so they may be recommended as an international standard by:
 - Building test-beds for advanced inverter testing (electrical performance and interoperability)
 - Comparing results from advanced DER functions

Questions?

Jay Johnson

Photovoltaic and Distributed Systems Integration

Sandia National Laboratories

P.O. Box 5800 MS1033

Albuquerque, NM 87185-1033

Phone: 505-284-9586

jjohns2@sandia.gov

References

- [1] T. Hsu, Los Angeles Times, "Gov. Brown pushes 12-gigawatt clean-power goal," July 26, 2011.
- [2] J.F. Wiedman, et al., Interstate Renewable Energy Council, "12,000 MW of Renewable Distributed Generation by 2020," July 2012.
- [3] Eltawil, Mohamed A., and Zhengming Zhao. "Grid-connected photovoltaic power systems: Technical and potential problems—A review." *Renewable and Sustainable Energy Reviews*, pp. 112-129, 2010.
- [4] Enslin, Johan HR. "Network impacts of high penetration of photovoltaic solar power systems." Power and Energy Society General Meeting, 2010 IEEE. IEEE, 2010.
- [5] J. Bank, B. Mather, J. Keller, and M. Coddington, "High Penetration Photovoltaic Case Study Report," NREL Technical Report TP-5500-54742, Jan 2013.
- [6] R. Elliott, R. Byrne, A. Ellis, L. Grant, "Small Signal Stability of the Western North American Power System with High Penetration of Photovoltaic Generation"(in development).
- [7] E. Malashenko, S. Appert, W. al-Mukdad, Advanced Inverter Technologies Report, CPUC Grid Planning and Reliability Energy Division, 18 Jan 2013.
- [8] International Electrotechnical Commission Technical Report IEC 61850-90-7, "Communication networks and systems for power utility automation—Part 90-7: Object models for power converters in distributed energy resources (DER) systems," Edition 1.0, Feb 2013.
- [9] Electric Power Research Institute (EPRI), Common Functions of Smart Inverters, Dec 2011.
- [10] J.W. Smith, W. Sunderman, R. Dugan, B. Seal, "Smart inverter volt/var control functions for high penetration of PV on distribution systems," Power Systems Conference and Exposition (PSCE), 2011 IEEE/PES , vol., no., pp.1,6, 20-23 March 2011.
- [11] NERC Performance of Distributed Energy Resources During and After System Disturbance , Voltage and Frequency Ride-Through Requirements , IVGTF1-
- [12] CEC/CPUC, Recommendations for Updating the Technical Requirements for Inverters in Distributed Energy Resources: Smart Inverter Working Group Recommendations, Jan 2014.
- [13] J. Neely, S. Gonzalez, M. Ropp, D. Schutz, "Accelerating Development of Advanced Inverters: Evaluation of Anti-Islanding Schemes with Grid Support Functions and Preliminary Laboratory Demonstration," Sandia National Laboratories Technical Report SAND2013-10231; November 2013.
- [14] M. Mills-Price, M. Scharf, et al., "Interconnection control of distributed generation with time-synchronized phasors," Power Systems Conference and Exposition (PSCE), 2011 IEEE/PES , pp.1,8, 20-23 March 2011.
- [15] VDE, "The 50.2 Hz problem: Controlling active power in the event of overfrequency in generators connected to the low-voltage distribution network", available from: <http://www.vde.com/en/fnn/pages/50-2-hz.aspx>
- [16] NERC, "A Technical Reference Paper Fault-Induced Delayed Voltage Recovery", V1.2, June 2009.
- [17] Implementation Voltage and Frequency Ride-Through Requirements in DER Interconnection Standards, SAND2014-XXXX, April 2014