

Development, Field Testing, and Evaluation of LIDAR-Assisted Controls

Robert Ehrmann¹, Na Wang², Andrew Scholbrock², Marc Guadayol³, Alan Wright², Dhiraj Arora¹
ALSTOM Wind (Richmond, VA)¹, NREL², ALSTOM Wind (Barcelona, Spain)³

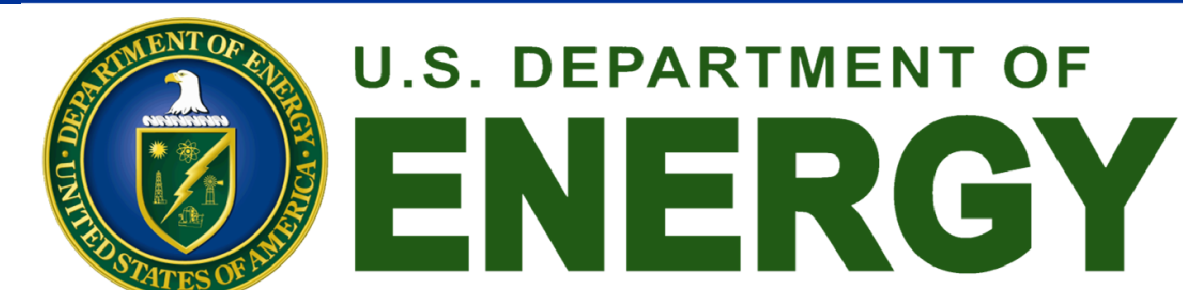

Abstract

Typical wind turbines utilize feedback controllers which have a delayed response to wind speed disturbances. A nacelle mounted Light Detection and Ranging (LIDAR) system measures a preview wind signal in front of the turbine. This can be included in a feed-forward control system, improving turbine pitch command for incoming variations in wind speed. The overall aim is reduced blade and tower fatigue, and potentially improved annual energy production. To be successful, the LIDAR must yield accurate wind speed measurements. Therefore, a LIDAR was characterized against a nearby met tower and turbine wind speed estimator. Results indicate good correlation between measurements.

Introduction

The United States has an offshore wind energy potential of 4,000 GW near heavy population centers. However, U.S. offshore wind is more challenging due to water depth and hurricane risk. To accelerate offshore wind growth, the U.S. Department of Energy is funding technology development and demonstration projects. One technology being investigated uses a LIDAR measurement to preview the wind speed and then update the pitch rate for incoming wind gusts. This potentially reduces tower and blade fatigue and generator speed variations.

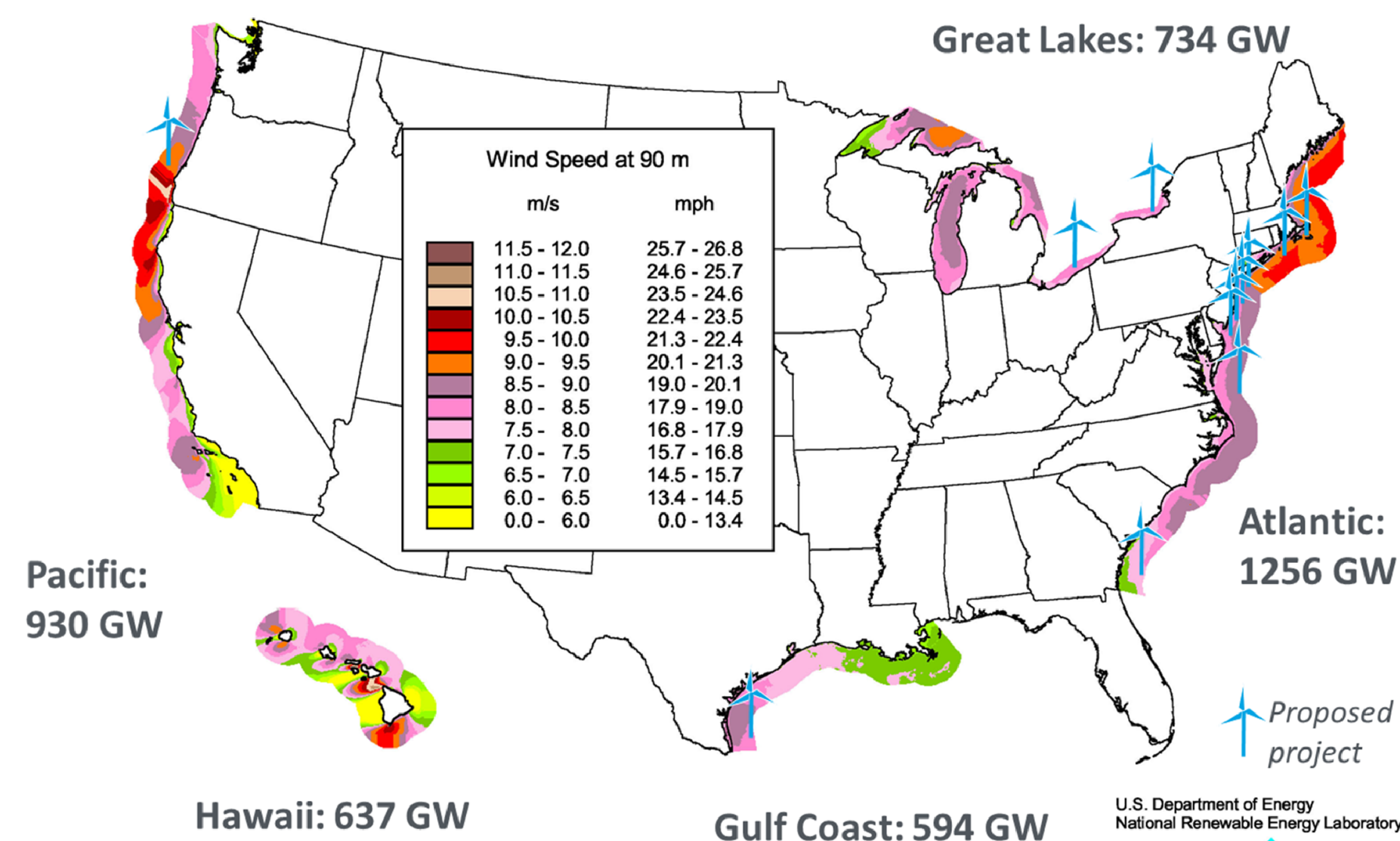

Offshore wind speed at 90 m with regional installed potential indicated.

LIDAR Assisted Control Design

Turbine feedback control operates based on generator power, tower motion, and RPM measurements to update blade pitch and torque. With a LIDAR sensing a preview wind speed, the pitch can be updated before the wind arrives, reducing tower and blade fatigue and generator speed variations.

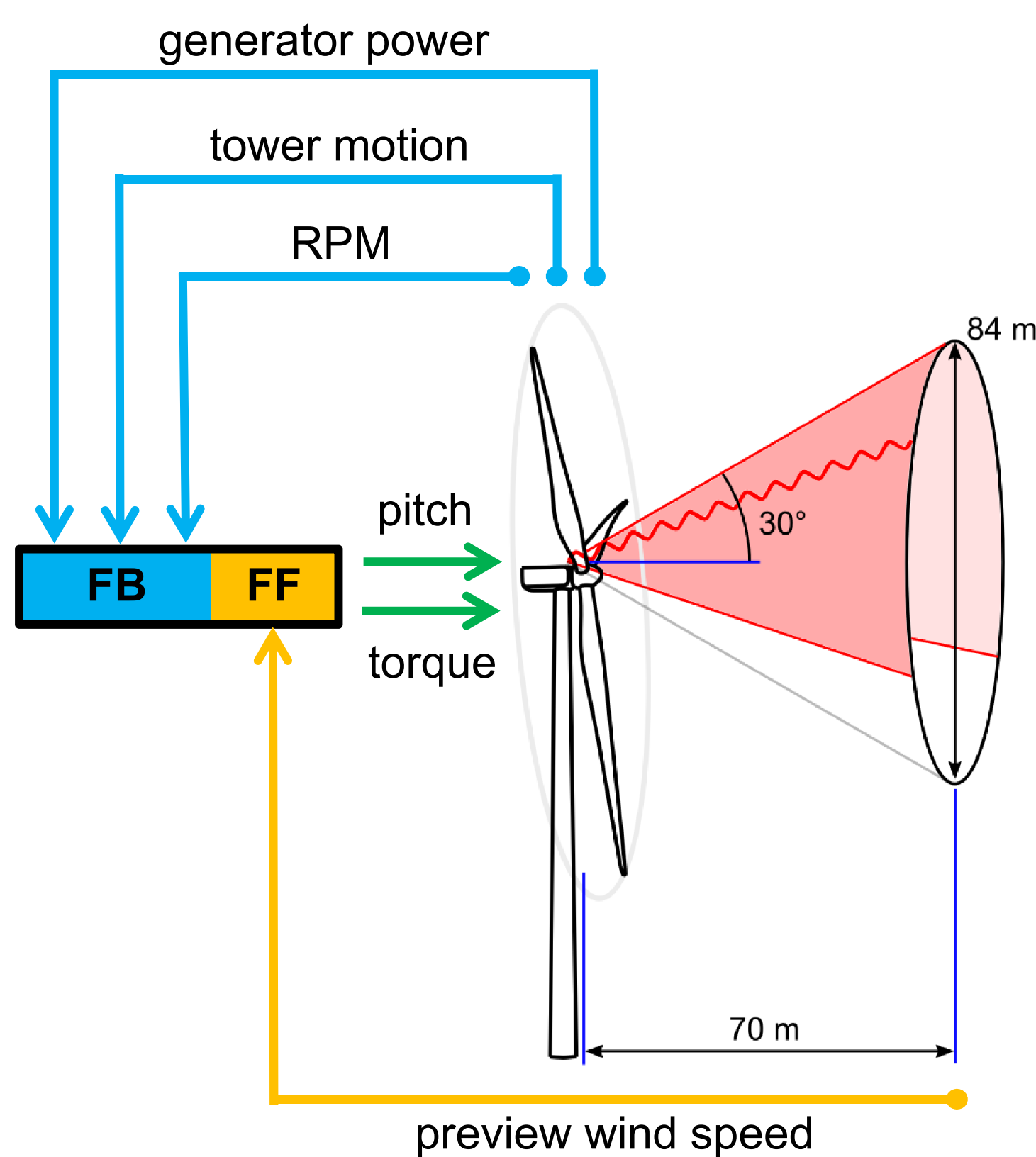

Schematic of LIDAR feed-forward control system.

Pre-installation Considerations

A ZephIR DM LIDAR was chosen due to its high sample rate, good accuracy, and impressive track record. A 30° half-cone angle and 73 meter range is used to acquire the optimal wind-speed preview measurement. Two installation locations were investigated, with the centerline location chosen, despite LIDAR beam hub-clipping, shown below.

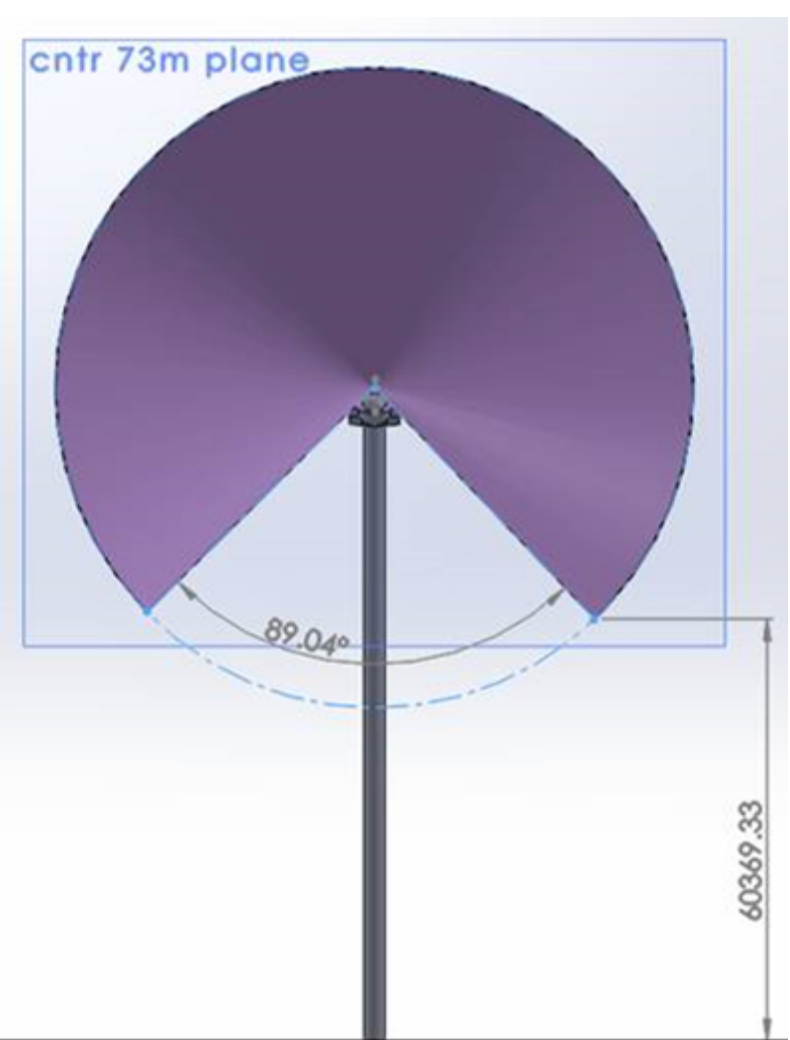

LIDAR hub-clipping check



LIDAR installed on ECO110

Safety is paramount and considerations were made for:

- LIDAR wind load
- LASER eye safety
- Lightning
- Installation

Experimental Setup

Testing took place at the National Renewable Energy Laboratory (NREL) National Wind Technology Center (NWTC) south of Boulder, Colorado. The test turbine was Alstom's 3MW ECO110. A met tower 228 m from the turbine was used for wind speed comparisons.

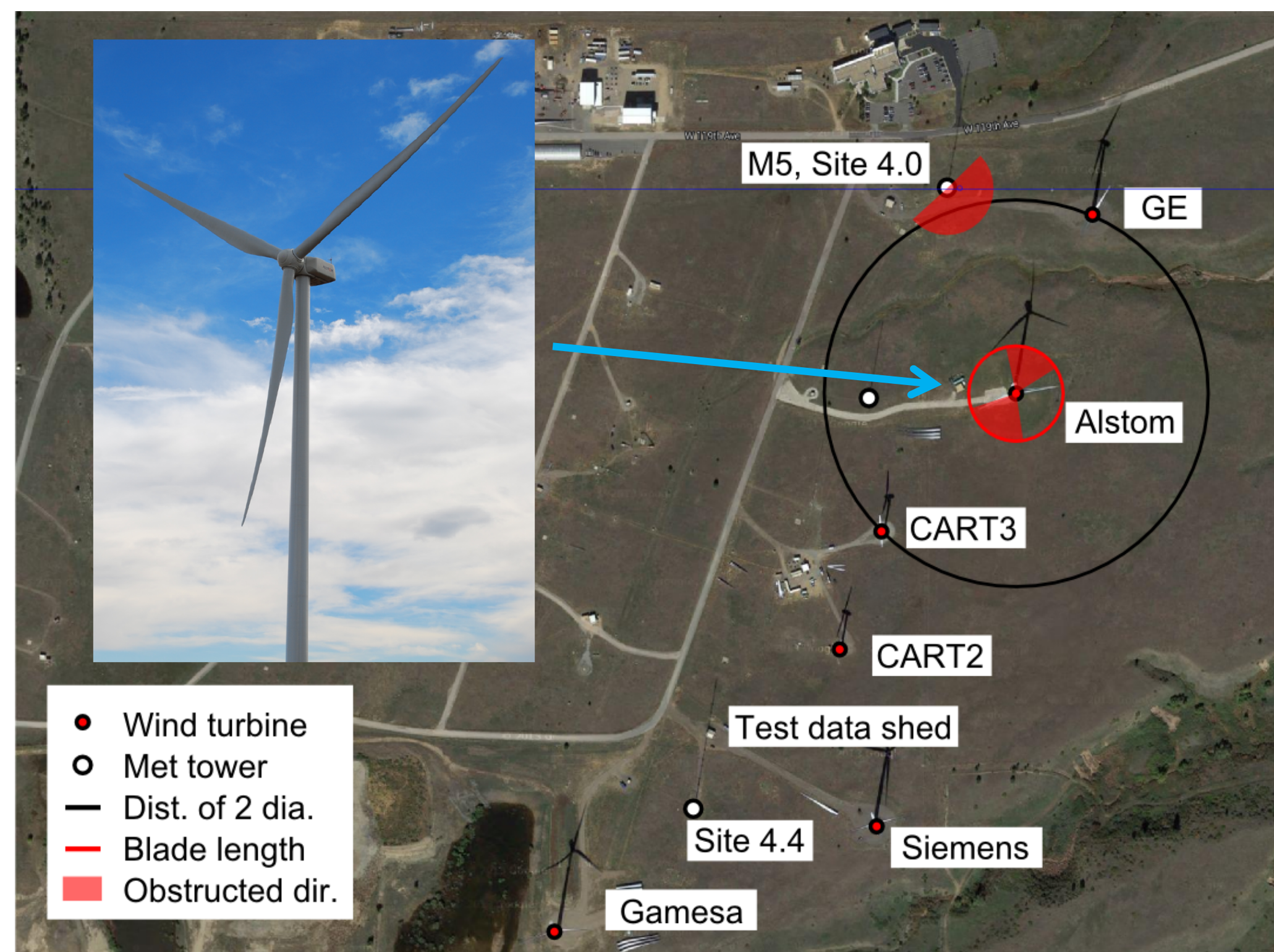

NREL NWTC test site (photo courtesy of J. Campbell).

Methods – Test Plan

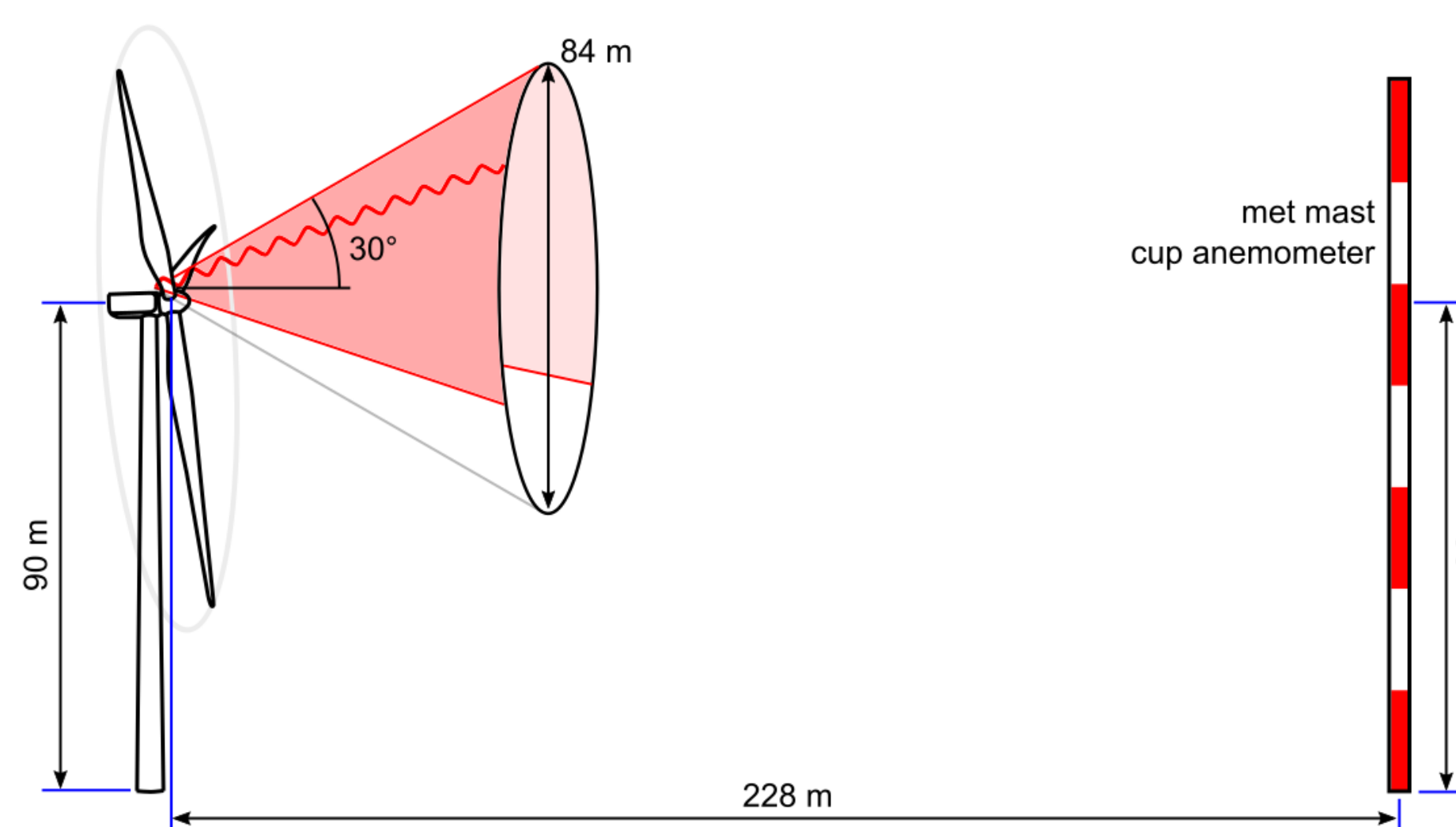

LIDAR met tower validation configuration.

Phase I, Test 1: LIDAR validation against met tower anemometer

The large distance between the met tower and turbine makes a direct comparison difficult. Therefore, for the met tower comparison, 10 minute averaged statistics were compared. The capture matrix was 1 m/s wind speed bins from 3 m/s to 25 m/s.

Phase I, Test 2: LIDAR validation against rotor effective wind speed

The LIDAR time series was compared against the rotor effective wind speed (REWS). REWS is calculated with an extended Kalman filter (EKF) using measurements from the turbine torque, rotor speed, and blade pitch. The LIDAR signal leads the REWS and is corrected using Taylor's hypothesis.

LIDAR acceptance criteria.

Test Name	Test Description	Criteria
Average Wind Speed	Compare 10 min average wind speed with met mast at 90 m	Sufficient bins, rms < 1.0 m/s
Average Wind Direction	Compare 10 min average direction with met mast direction at 87 m	Sufficient bins, rms < 15°
Duration	A total of 100 hours of data while the turbine is operating	Overall test time > 100 hrs
Time Series Wind Speed Comparison	Compare 1 Hz LIDAR data with rotor estimated wind speed	Sufficient bins, rms < 1.5 m/s
Phase	Measured delay between LIDAR and REWS over 10 min segment	< 5% variation between theoretical and measured delay

Acknowledgments

The Department of Energy's funding and support of Contract DE-EE-0005494: Advanced Controls for TLP Wind Turbines is greatly acknowledged. A special thanks to ZephIR LIDAR, David Schlipf with NREL, and GAI Consultants Inc. DOE-Alstom-0005494-1

Results

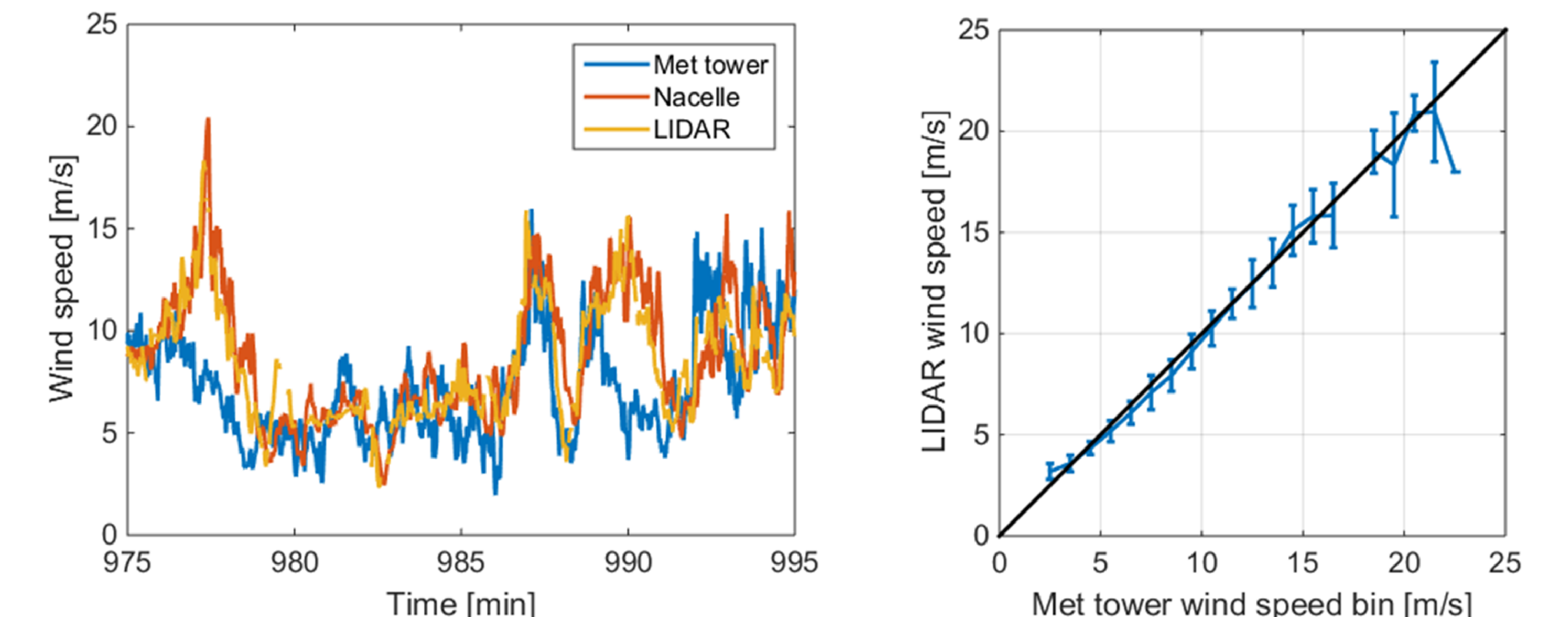

Met tower illustrates occasional offset.

The 10 min. average wind speed is well-correlated.

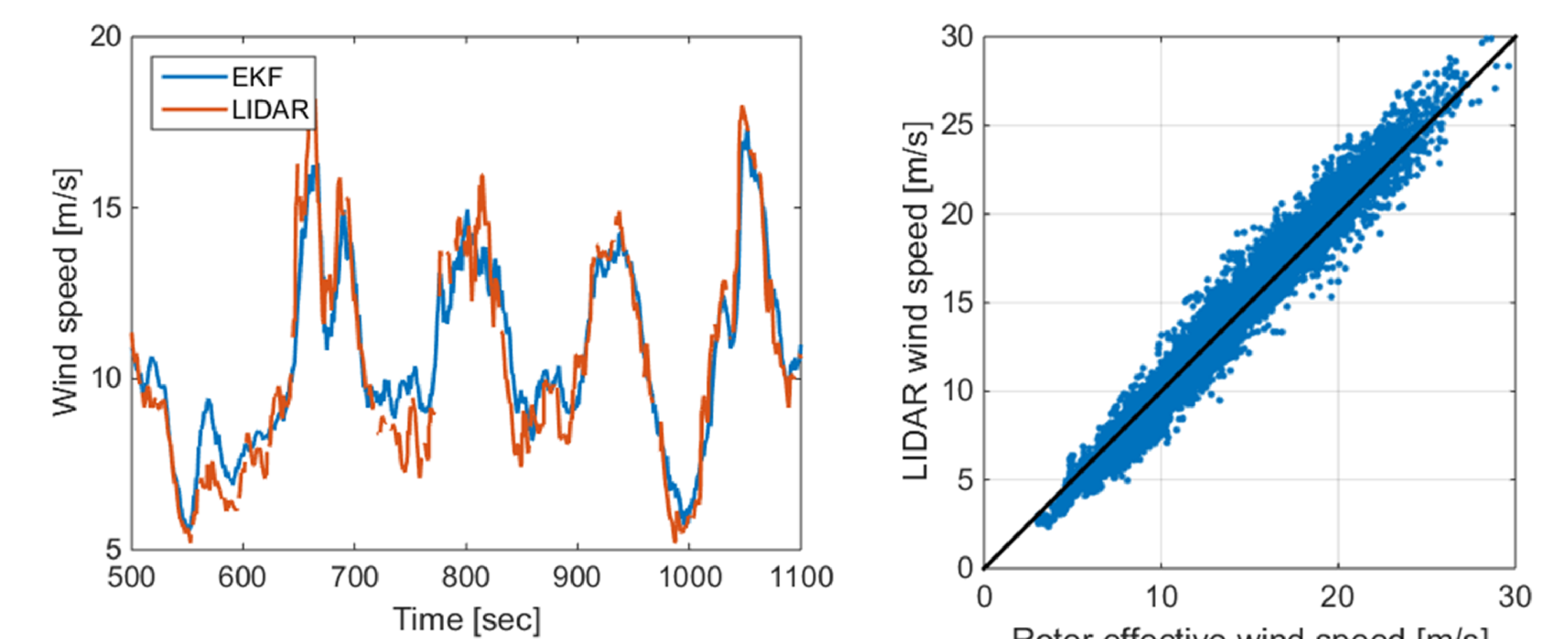

EKF and LIDAR time series comparison.

REWS and LIDAR scatter plot.

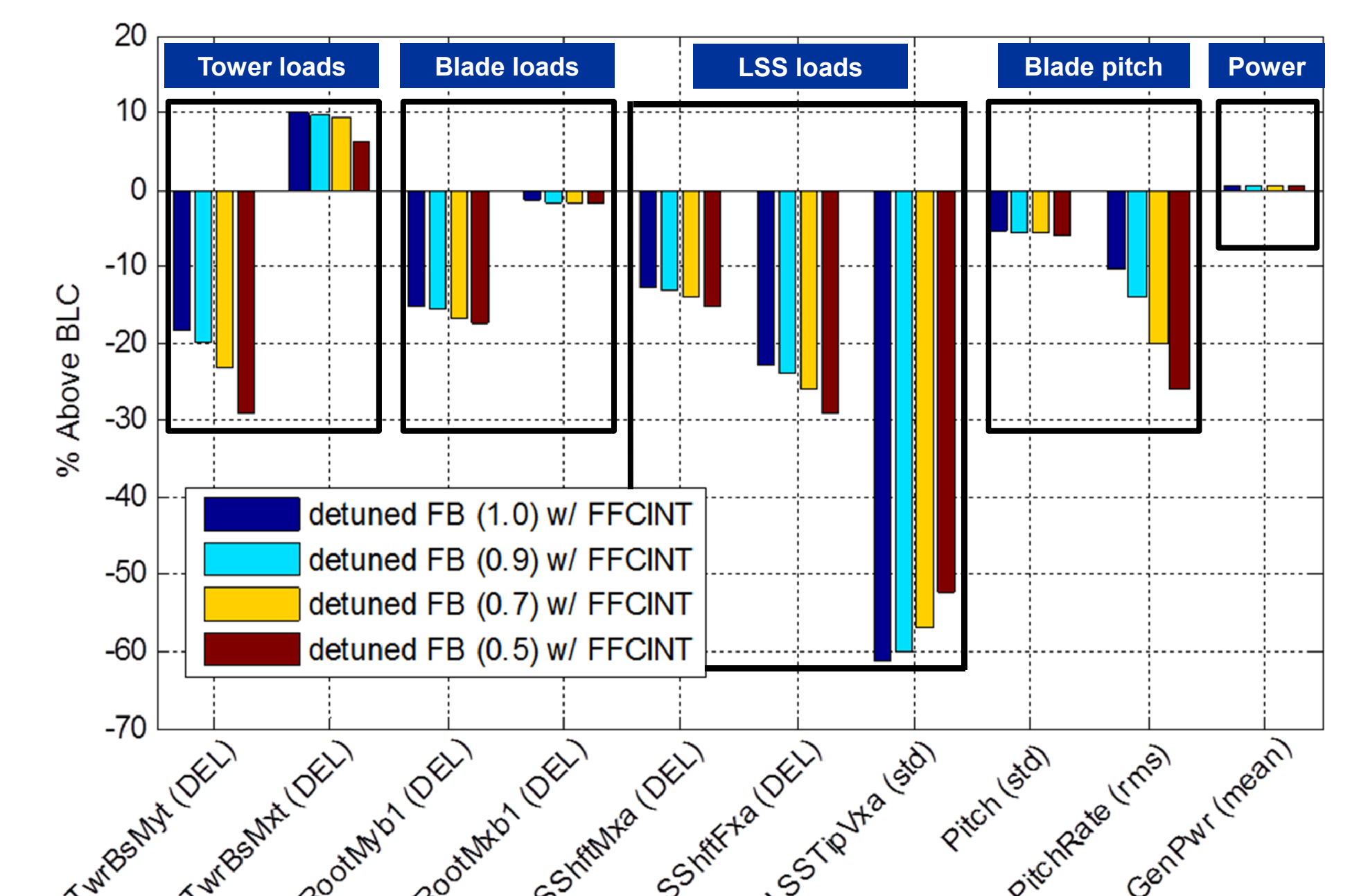

Key performance indicators of simulated LIDAR-based feed-forward control.

Conclusions

The LIDAR system has been shown to accurately measure the incoming wind speed.

- LIDAR and met tower 10 minute averages have a 0.8 m/s rms error
- LIDAR and REWS 1 Hz time series have overall rms error of 0.77 m/s
- Simulations indicate tower and blade loads and LSS stdev. decrease
- Small increase in baseline power

Future Work

- Failure Modes, Effects, and Criticality Analysis

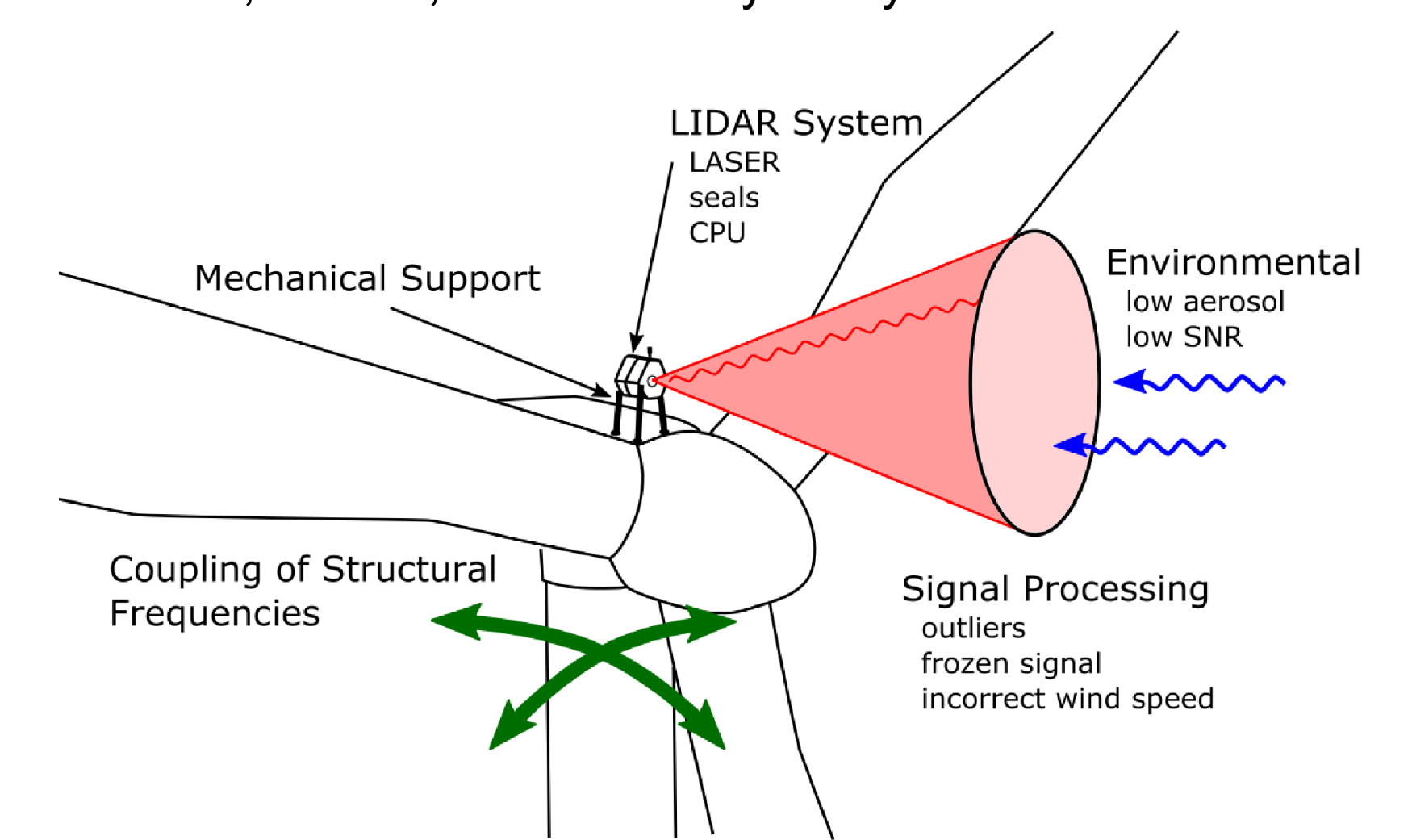

- Software / Hardware Integration
The wind turbine controller is being updated to include a feed-forward control system.
- Testing with Feed-forward Controller
Once the updated controller is validated, the wind turbine will operate in closed-loop configuration with the feed-forward pitch rate used to update blade pitch. Blade loads, tower base loads, and generator speed will be monitored and compared. The controller will be tuned to optimize performance.