

Exceptional service in the national interest

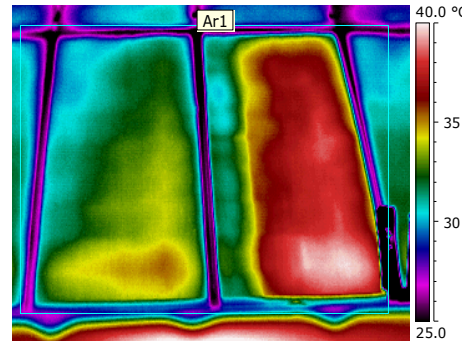

PV Reliability Operations Maintenance (PVRM) - Mitigating O&M Risks Through Fault and Failure Analysis

Geoffrey T. Klise and Colin J. Hamman
Sandia National Laboratories
May 7, 2014



Sandia National Laboratories is a multi-program laboratory managed and operated by Sandia Corporation, a wholly owned subsidiary of Lockheed Martin Corporation, for the U.S. Department of Energy's National Nuclear Security Administration under contract DE-AC04-94AL85000.

Research Purpose – Improve PV System Reliability

- Develop PV Reliability Operations Maintenance (PVRM) database and *process* into a Best Practice
 - Failure Report, Analysis, and Corrective Action (FRACAS) database
 - Relies on industry participation (data) to demonstrate value
- Facilitate WG to tackle topics on improving PV *System* reliability
 - Standards/best practices review
 - PV O&M workshop
 - Failure analysis reporting/best practices
 - Preventative Maintenance
 - Reliability Block Diagrams
 - Data Reporting (KPIs, definitions)
 - Scenario cost modeling

PVROM – Benefits to Industry

- Reveal how PV systems are being maintained and how industry is responding to faults and failures
 - Convey results in a way that can lead to better system design
- **Track how faults and failures are being addressed along with the cost to bring PV system back to full operation**
- Reveal scenarios where sparing may be a good O&M practice. e.g., which component, how many. When is the best time for a truck roll
- **Utilize statistical results to develop probabilistic representations of component failure**
 - This information can result in more accurate performance models
 - Use Sandia's PV-RPM model for scenario development

PVROM – Current Efforts

- To facilitate the gathering and analysis of O&M collected in the field, the PVROM effort is currently:
 - Recruiting industry partners to input their PV plant data into the PVROM database,
 - Training and consulting with industry partners to assist with their data entry and retrieval,
 - Providing empirical analysis of plant reliability, availability, and other metrics,
 - Publishing of reports on trends observed from the PVROM data as well as data collection methods, and
 - Developing standardized O&M protocols for broad industry use

PVROM Status

- 4 existing partners – Discussions underway with 2-3 partners and up to 4 new PV systems
- Actively working with existing partners to collect and input data into the database. Focus of this year's work
- Developing Requirements Document that outlines analysis benefits as a function of input data provided by partner

PV System Lifecycle

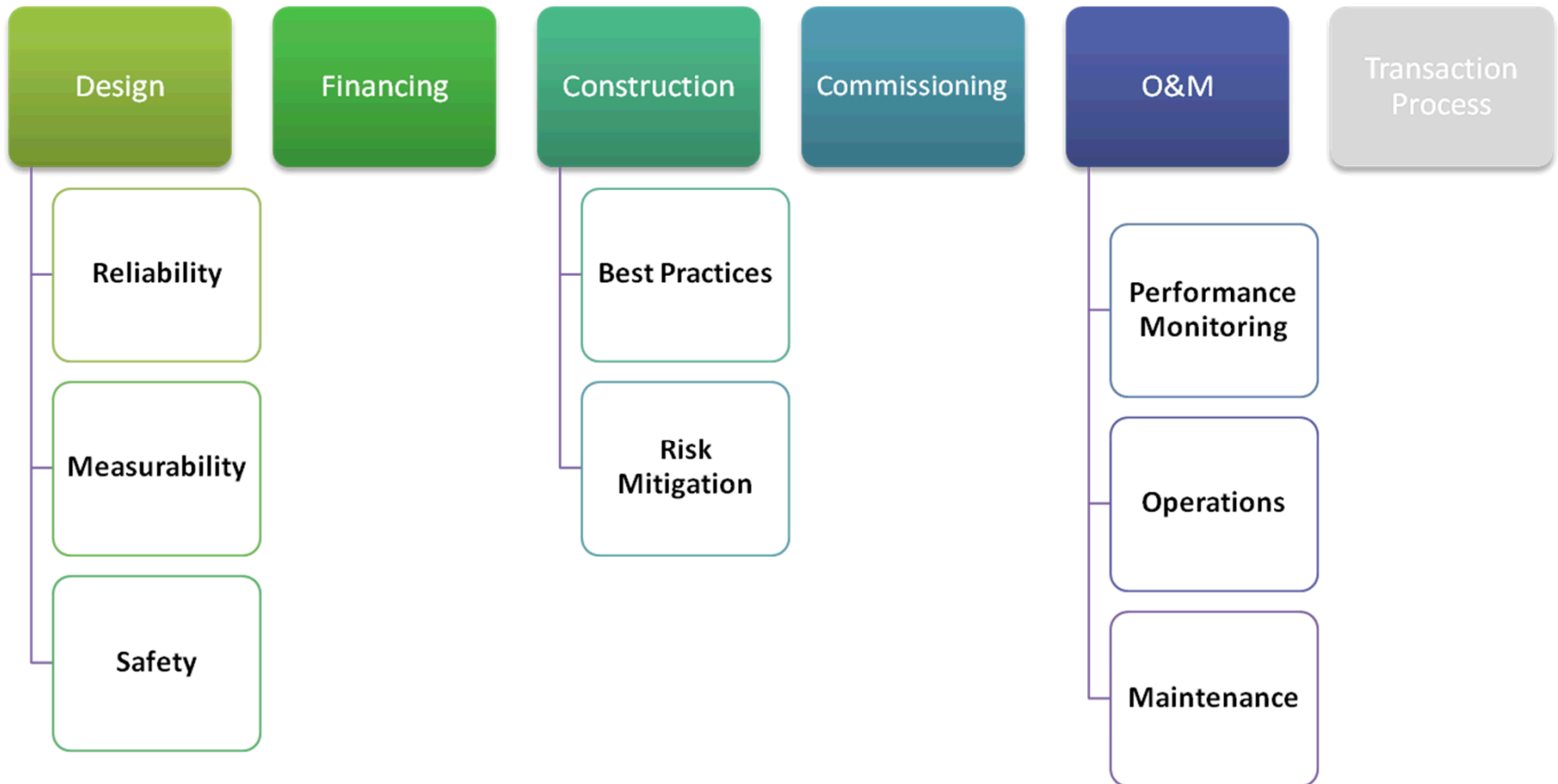

PV System Lifecycle

System does not change hands

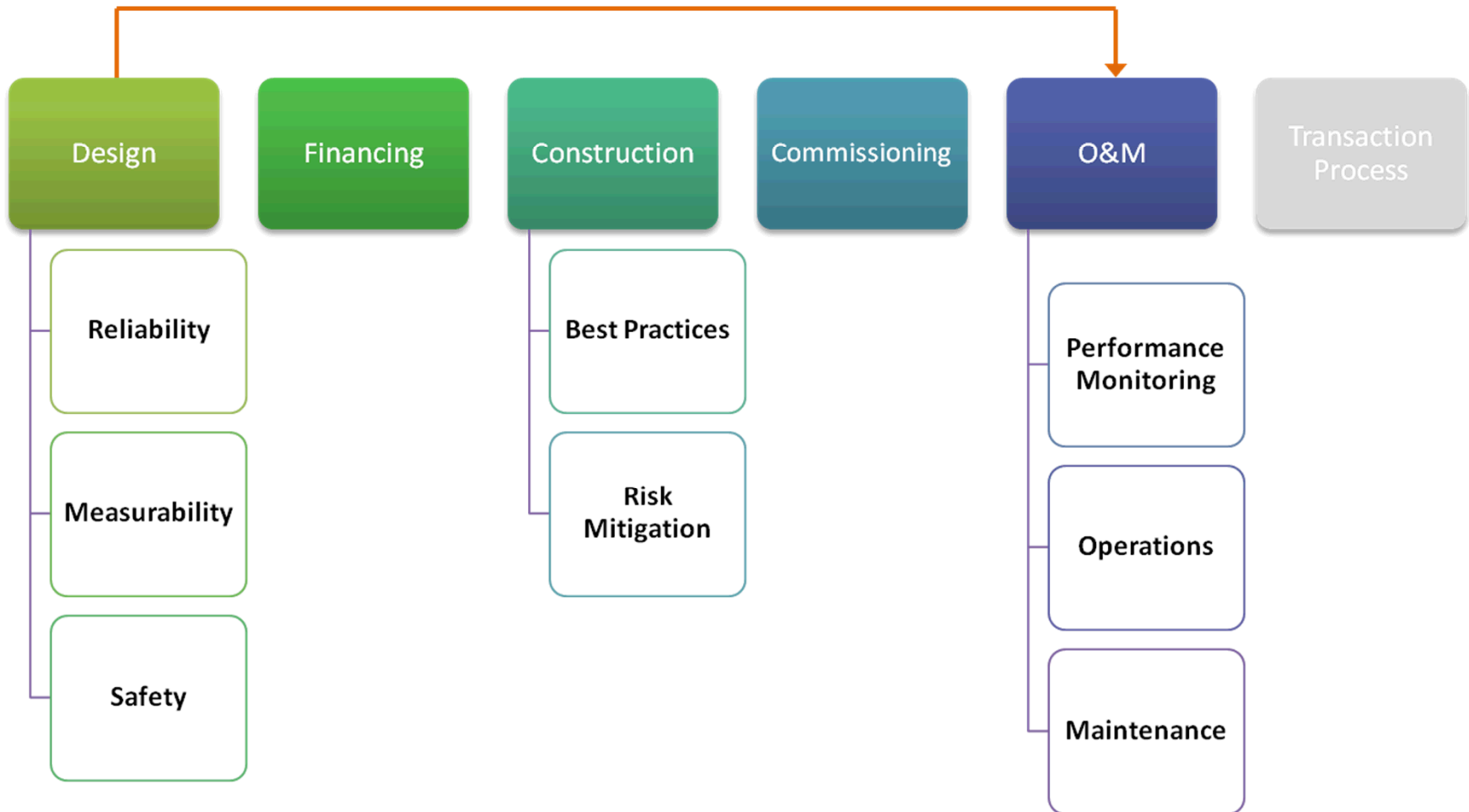

PV System Lifecycle

System changes hands once

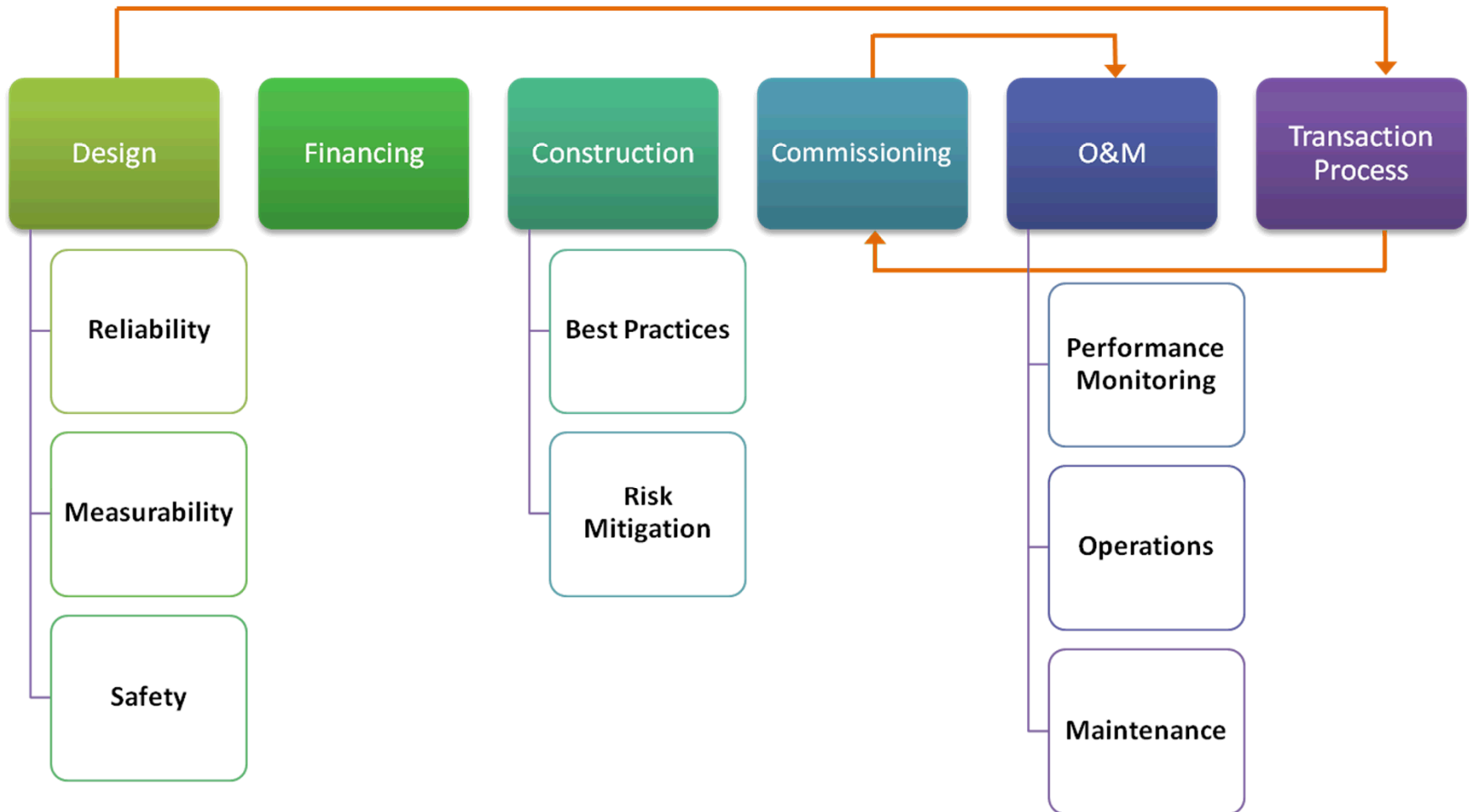

PV System Lifecycle

System changes hands 2x or more

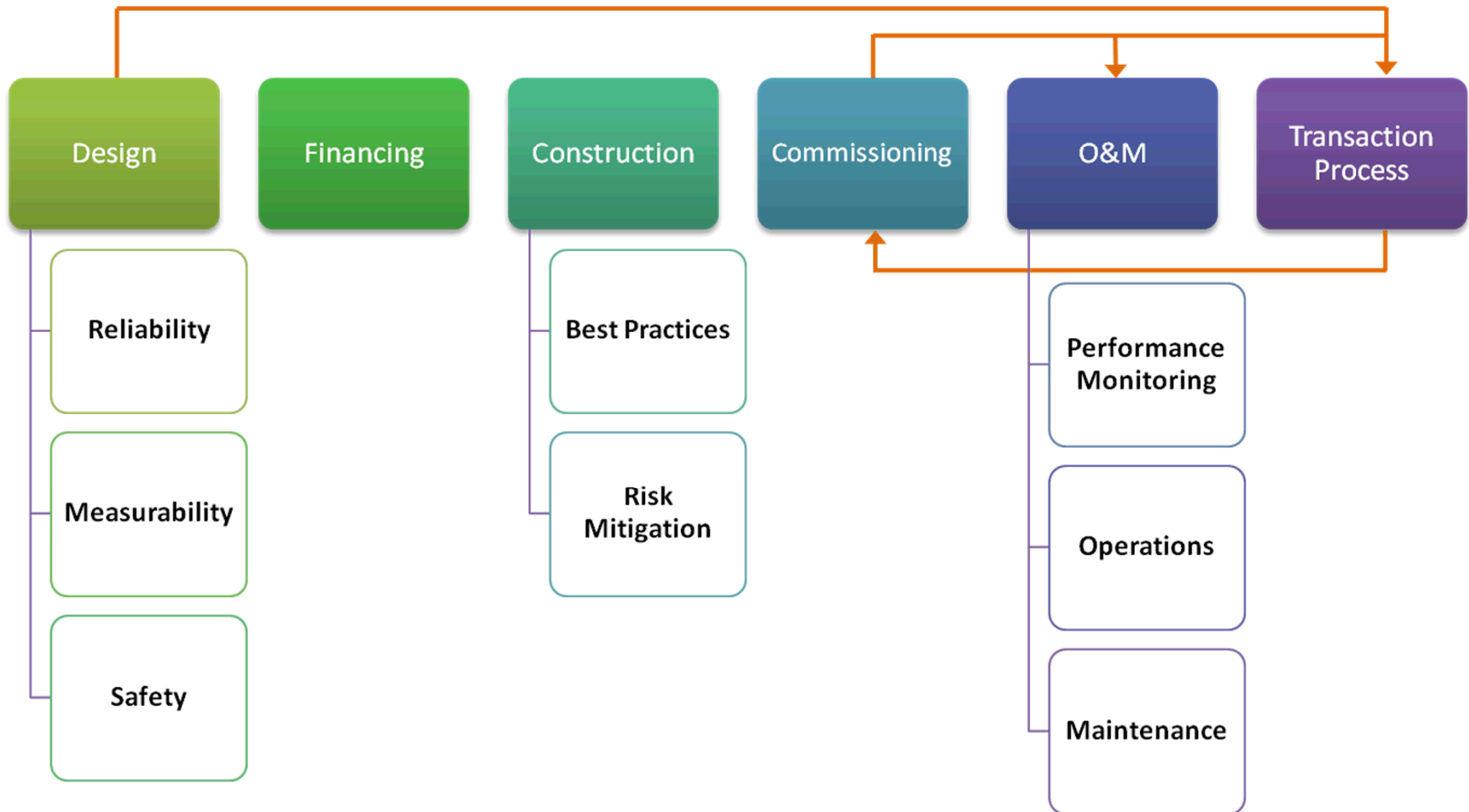

PV System Lifecycle

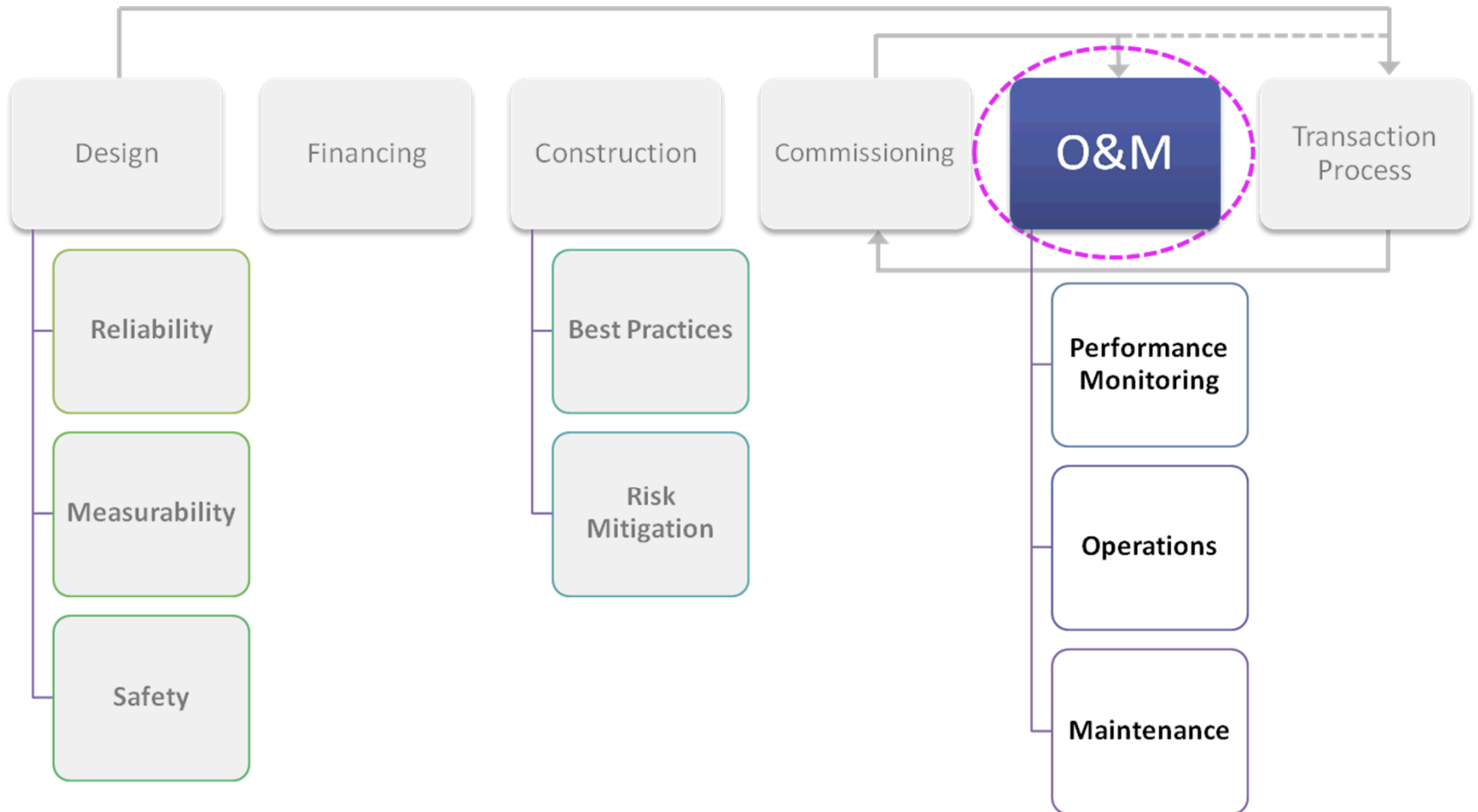

PV System Lifecycle

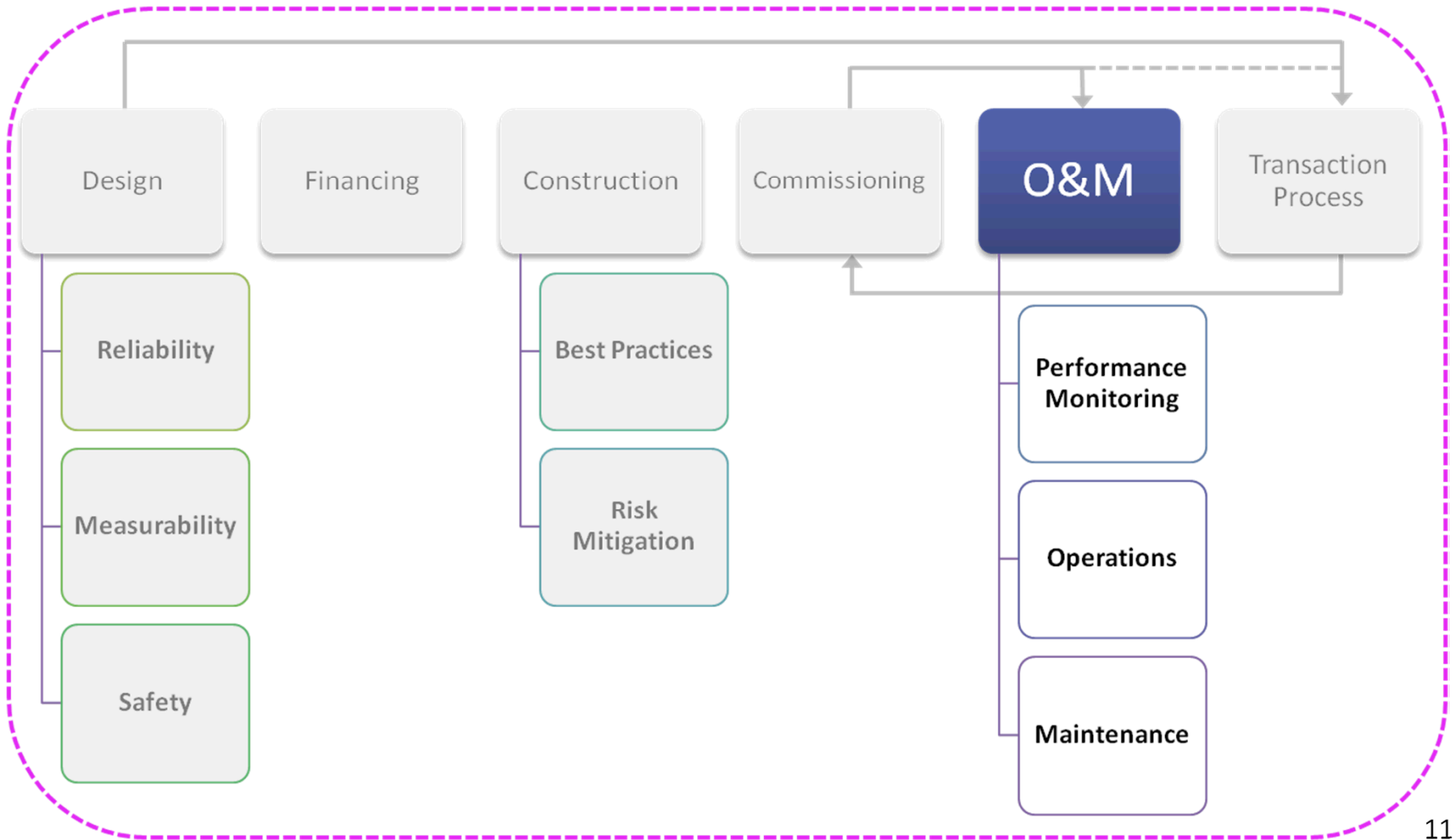

PV Reliability Operations Maintenance (PVRROM) as a *Database* and a *Process*

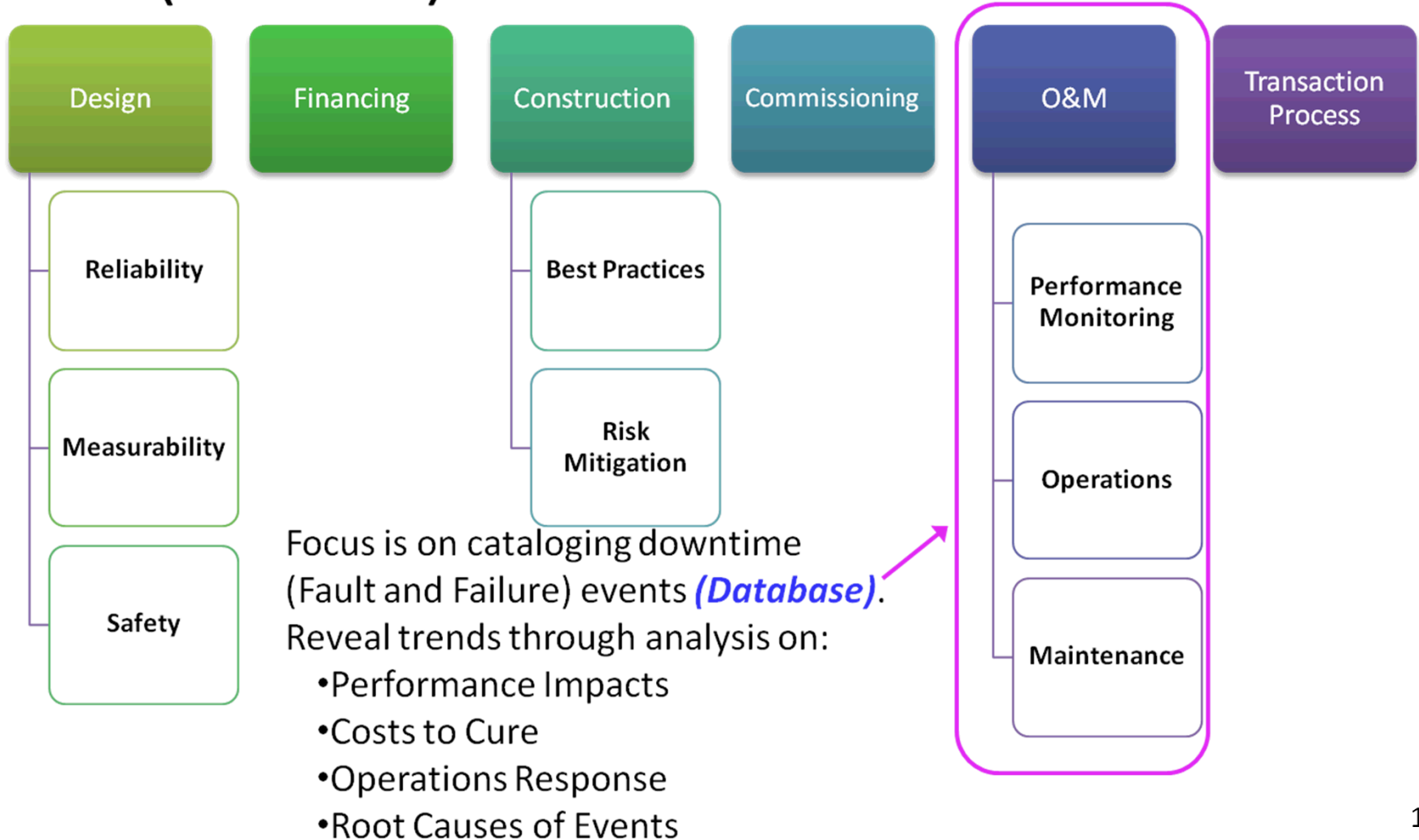

PV Reliability Operations Maintenance (PVRROM) as a *Database* and a *Process*

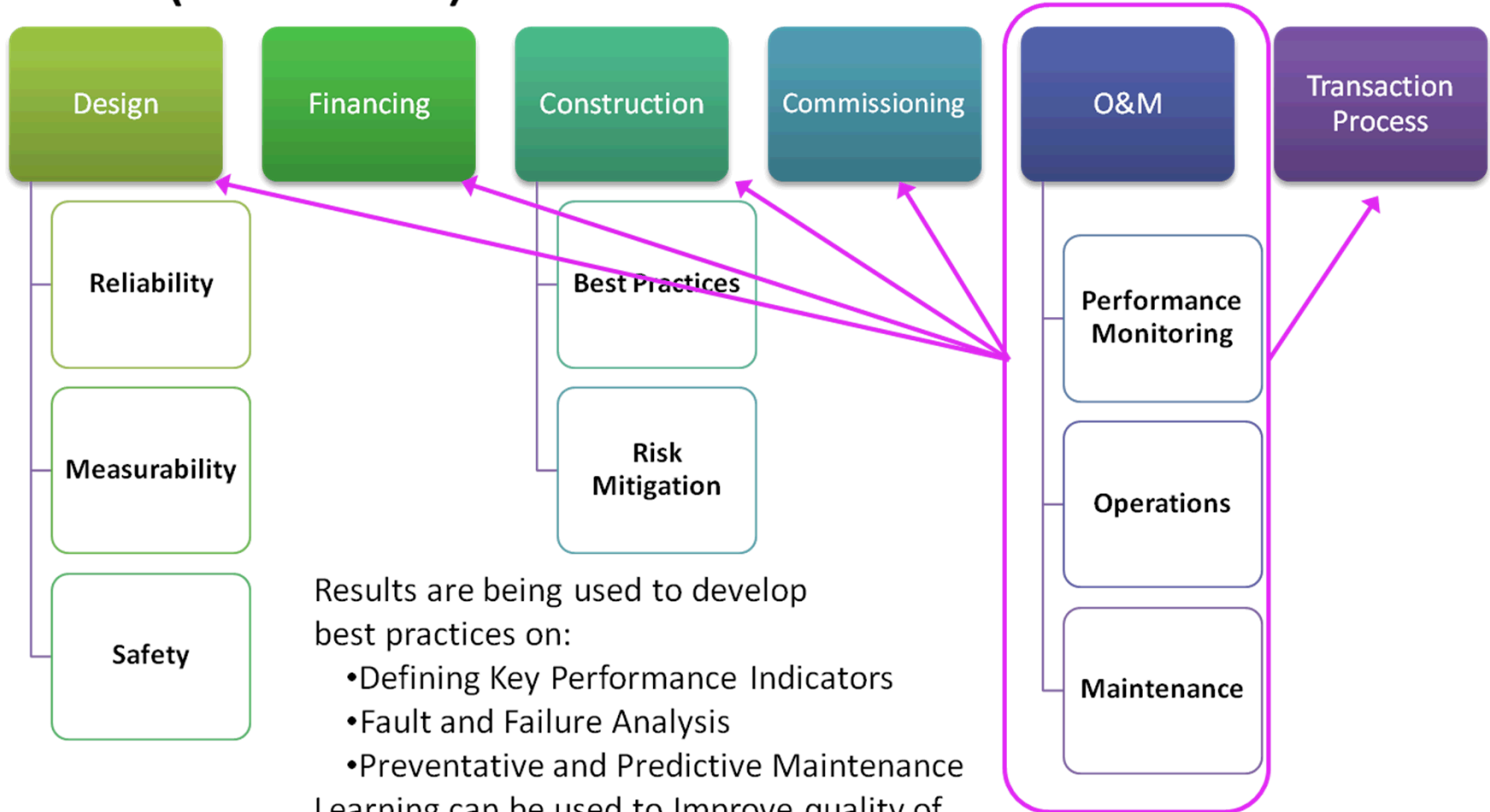

Results are being used to develop best practices on:

- Defining Key Performance Indicators
- Fault and Failure Analysis
- Preventative and Predictive Maintenance

Learning can be used to Improve quality of Design, Construction, Commissioning and O&M (*Process*).

PV Reliability Operations Maintenance (PVRROM) as a *Database* and a *Process*

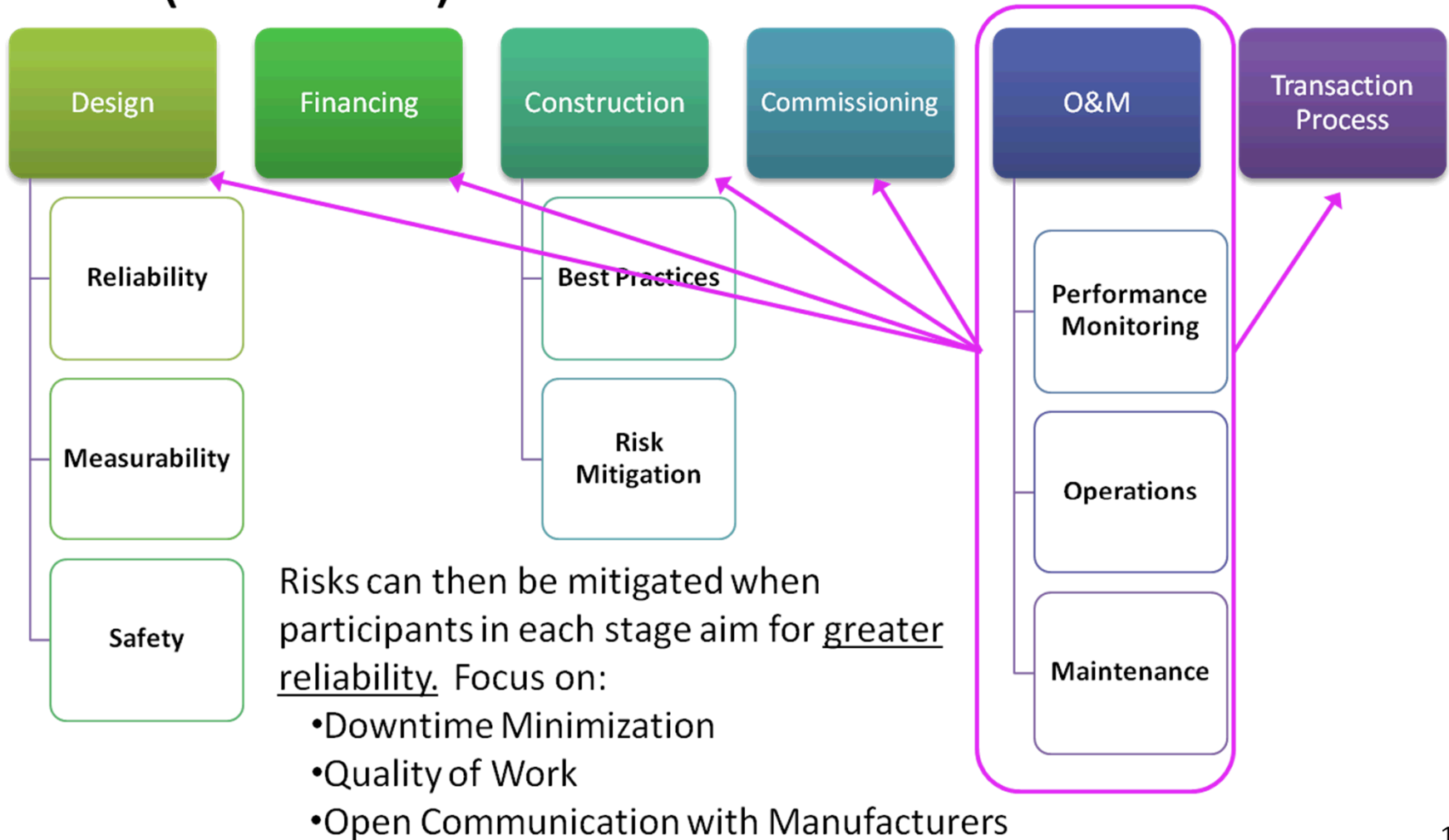

Data Partner Example

- Initial information input into the PVRM database has provided a starting point for analysis that will be expanded upon in future years.
- First years findings are based on twenty months of incident data reported in PVRM
 - Incident Data includes information covering plant operational deviations/failures, unplanned outage events, and associated mitigation activity
- This data is from a PVRM partner with two systems located in the U.S.

Partner Example, Continued

System Component	Abbreviation	Quantity	Maintenance Actions	Active Repairs	Avg. Corrective Maintenance Time (hrs)
AC Disconnect Switch	ADS	7	0	0	-
Combiner Box	CB	45	0	0	-
Data Acquisition System	DAS	2	2	2	1.0
Electric Motor	MOTOR	35	0	0	-
Hoses and Fittings	HOSE	35	0	0	-
HV Transformer	TXL	2	0	0	-
Hydraulic Cylinder	CYL	35	15	15	9.2
Hydraulic Pump	PUMP	35	0	0	-
Inverter	INV	7	8	0	0.5
Control Power Supply	CPS	7	1	1	8.0
Control Fan	FAN	7	0	0	-
Inverter Control Board	CRTLBRD	7	2	2	1.7
Inverter Control Software	CRTLSW	7	1	1	0.6
Matrix	MAT	14	4	4	2.8
LV Transformer	TXS	7	0	0	-

Cylinder failures didn't necessarily lead to an immediate outage

None of INV maintenance actions were hardware failures

INV failures and repairs reflect those at the top level

Partner Example, Continued

ECON represents a “basket” of miscellaneous connectors and other “small” electrical components

System Component	Abbreviation	Quantity	Maintenance Actions	Active Repairs	Avg. Corrective Maintenance Time (hrs)
Misc. Electrical Devices, Cables, Connectors	ECON	2	1	1	8.0
Programmable Logic Controller	PLC	35	8	8	2.6
PV String	STRING	540	0	0	-
PV Module	MOD	8100	1	1	8.0
Solenoid	SOL	35	0	0	-
Tank	TANK	35	0	0	-
Utility Disconnect Switch	UDS	2	0	0	-
Valve Stack	VALVE	35	0	0	-
Variable Frequency Drive	VFD	35	0	0	-

The only PV module failure was due to a debris strike

Partner Example, Continued

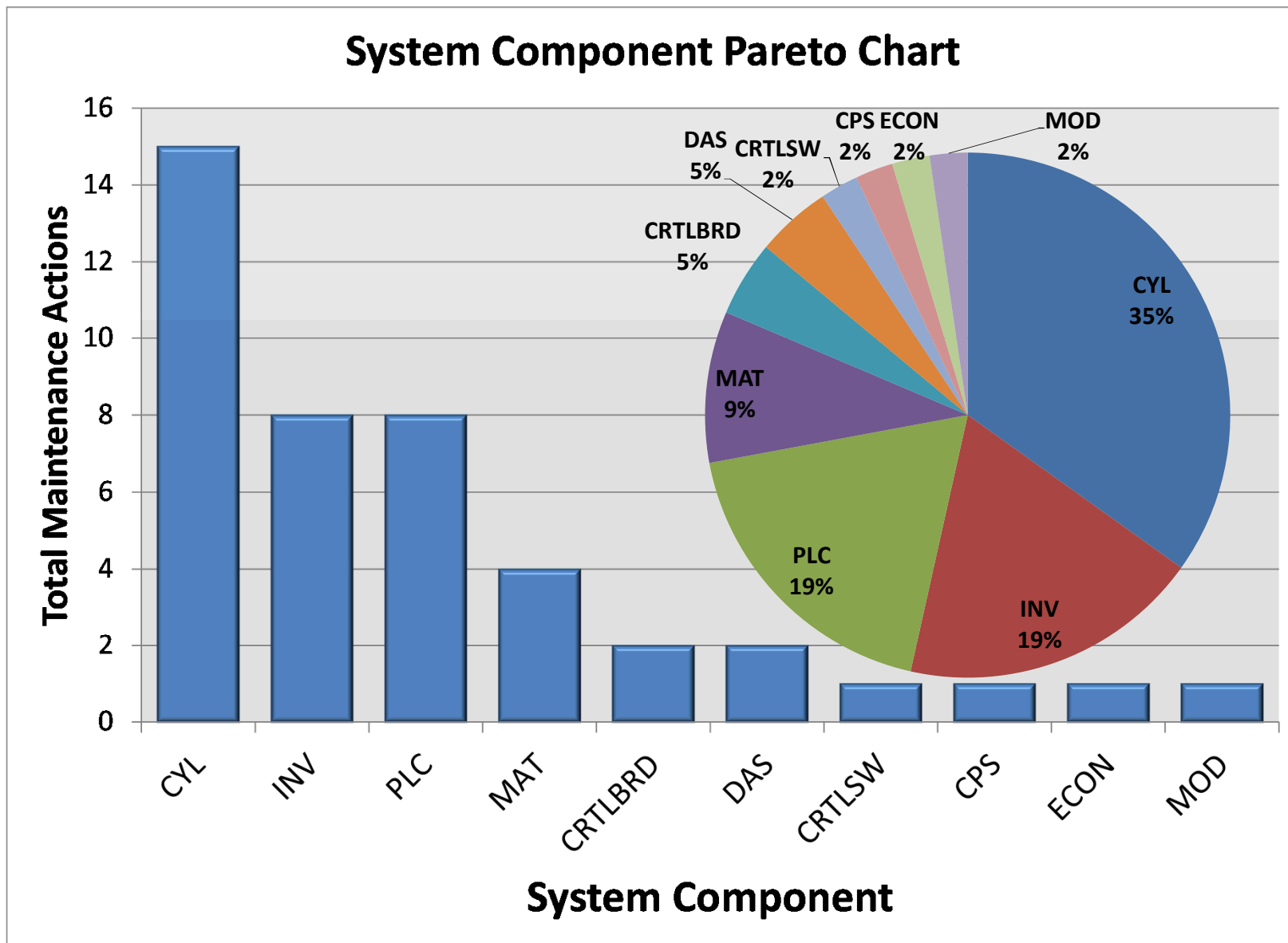

Partner Example, Continued

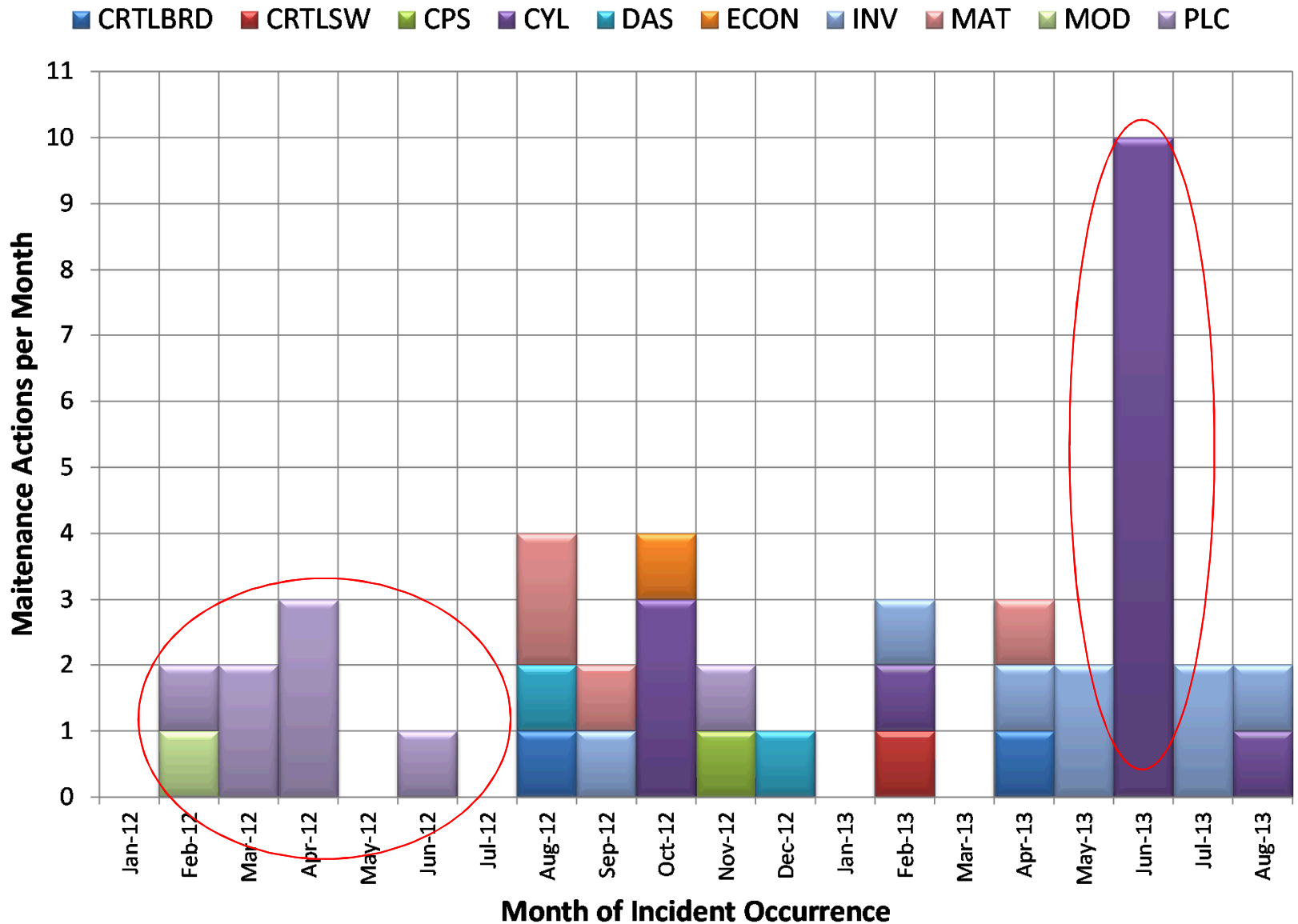

Interesting Results

- Trending
 - There was an increase in Hydraulic Cylinder (CYL) failures while there was a decrease in Programmable Logic Control (PLC) failures.
 - The majority of Hydraulic Cylinder failures are attributable to an incompatibility between a seal on a 3000 psi cylinder and the oil-type used.
 - PVROM helped alert system owners that there could be a systematic issue regarding these leaky cylinders
- PLCs had a configuration issue that caused premature failure of its internal circuitry. This issue was resolved early, that is why the failure rate decreased.

Interesting Results, Continued

Probability Plot - Hydraulic Cylinder Failure

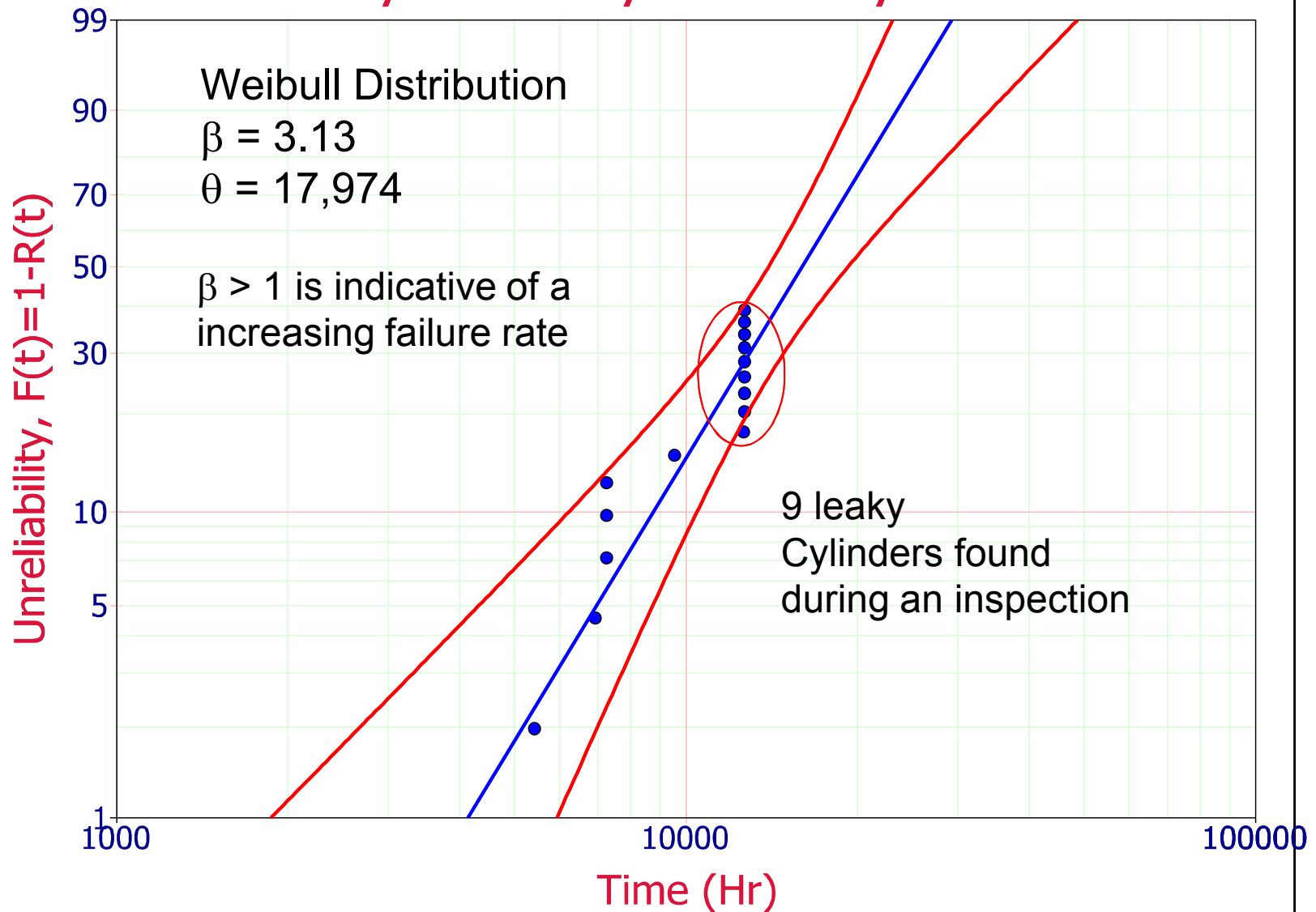

Interesting Results, Continued

- Inverters
 - At a system-level there were no actual hardware failures for the inverters. Most of the downtime of the inverters was caused by external disturbances

Prediction of O&M Performance

- The empirical data from the PVROM database can be used to create models to project future O&M performance for a PV system.
- A Reliability Block Diagram (RBD) is created which represents the system topology
- O&M performance parameters are assigned to the “blocks,” that is the line replaceable units (LRUs) of the system.
 - Failure Rates
 - Repair Rates
 - Logistical delays
 - Material and Labor Costs

System RBD

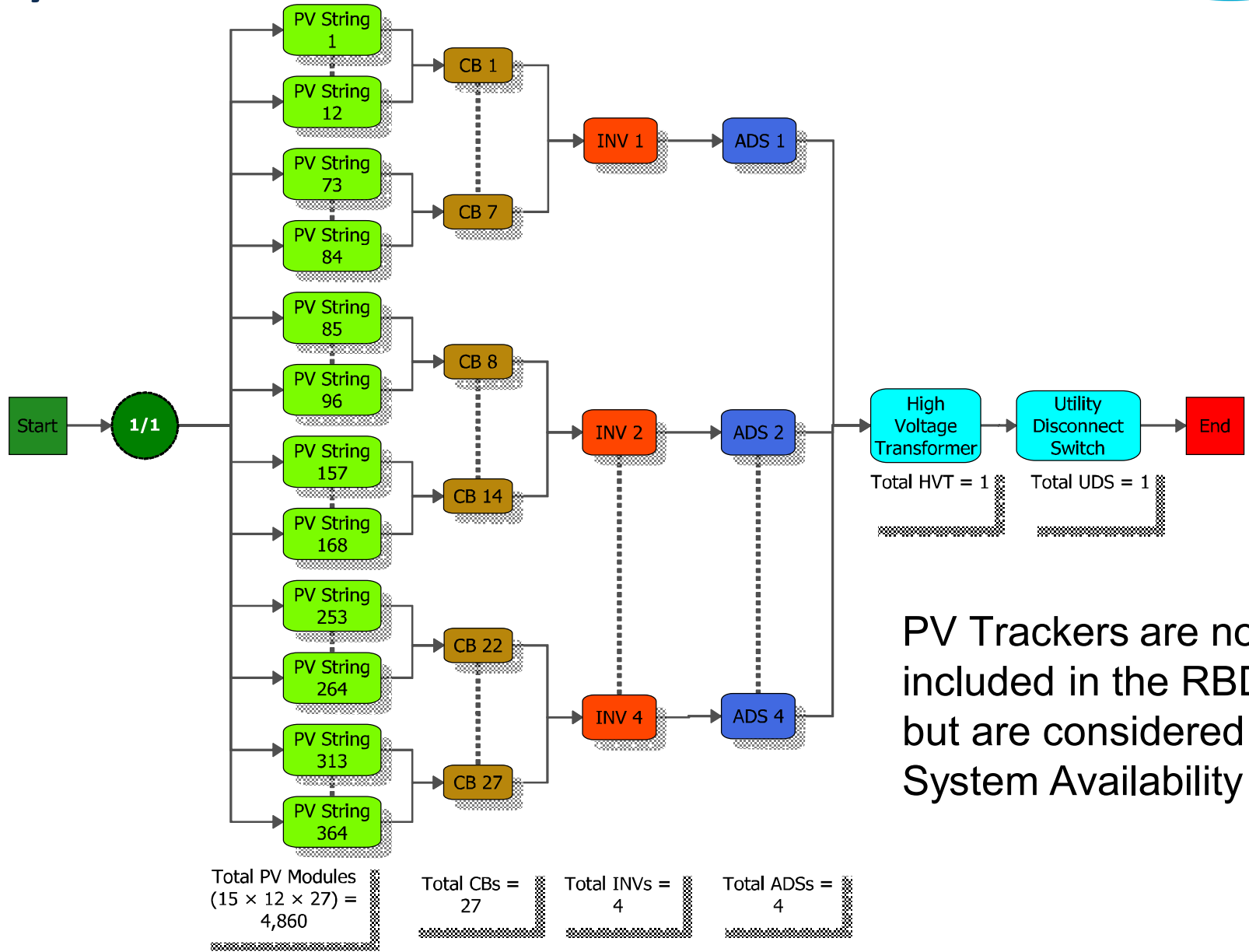

PV Trackers are not included in the RBD, but are considered in System Availability

Prediction of O&M Performance

- Using the data from PVROM we can “fit” statistical models

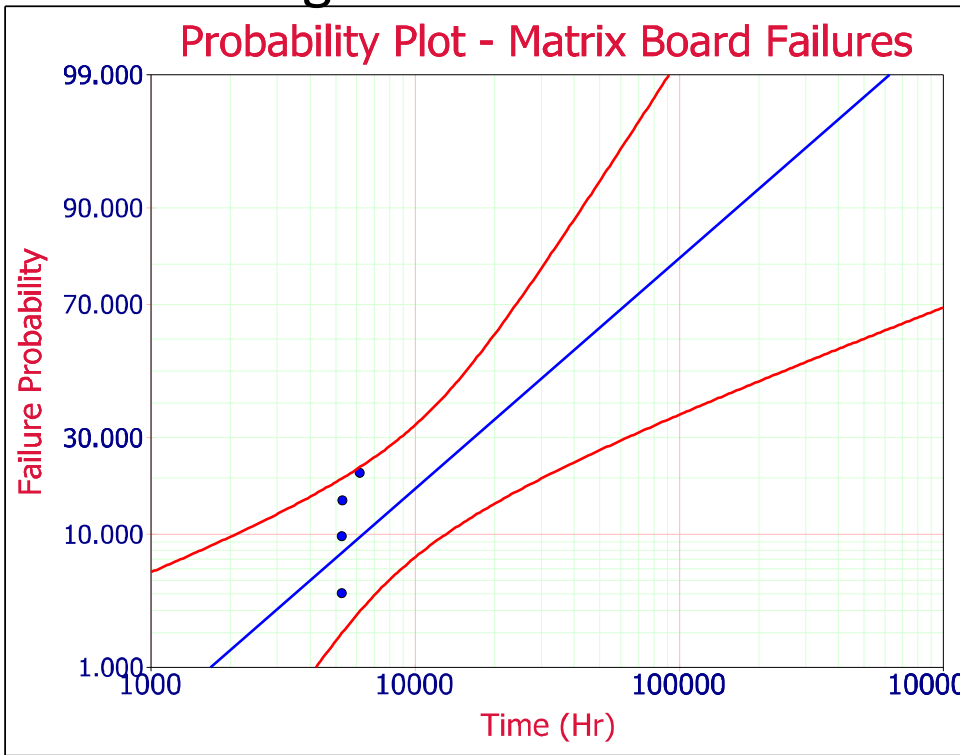

90% double-sided
confidence bounds
shown by **red** curves

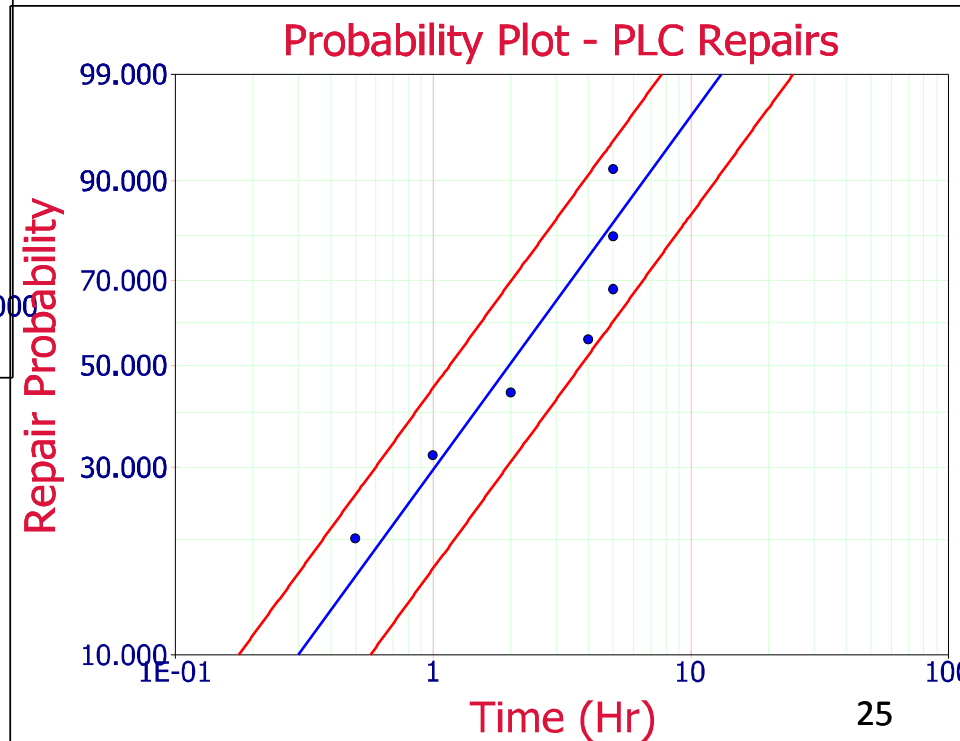

Prediction of O&M Performance

- With more data we can be more confident about our models

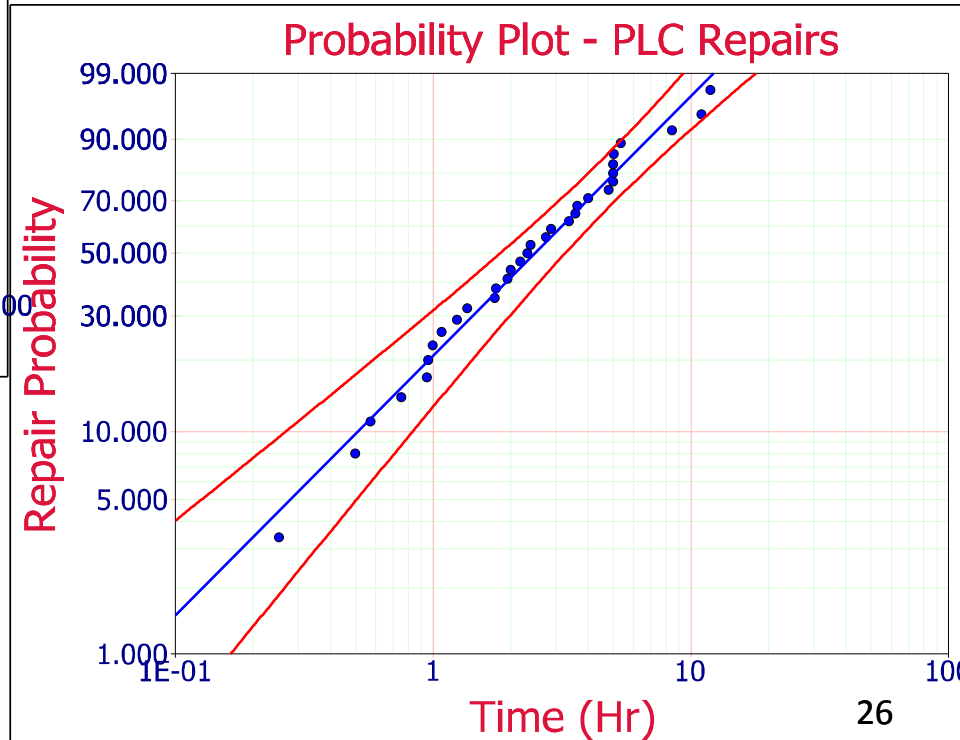
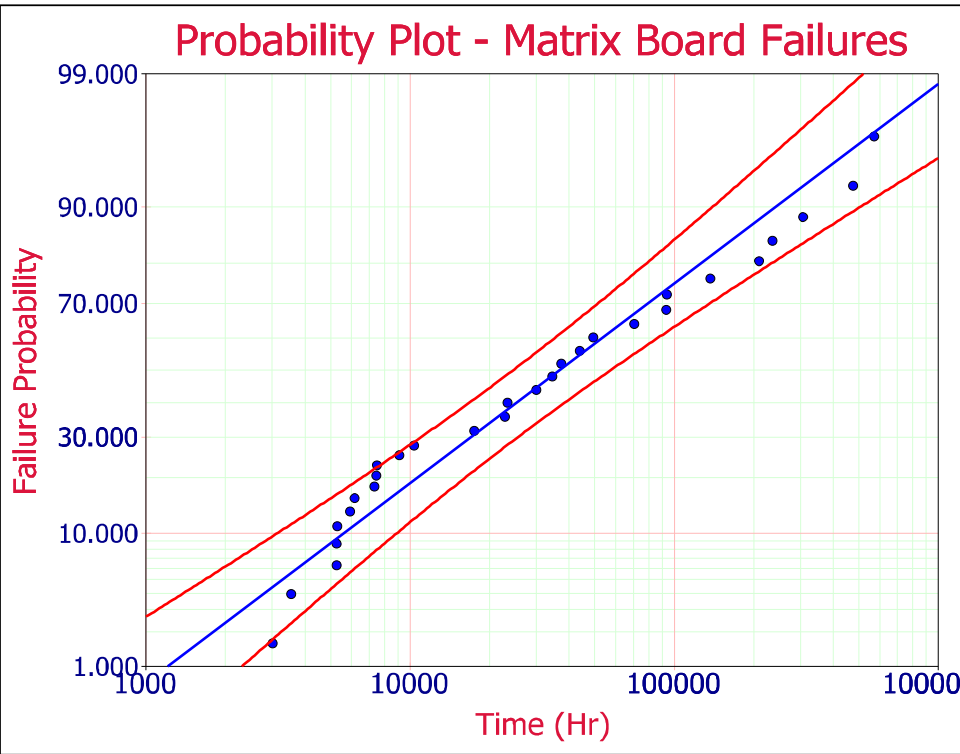

Impact of Maintenance on Power

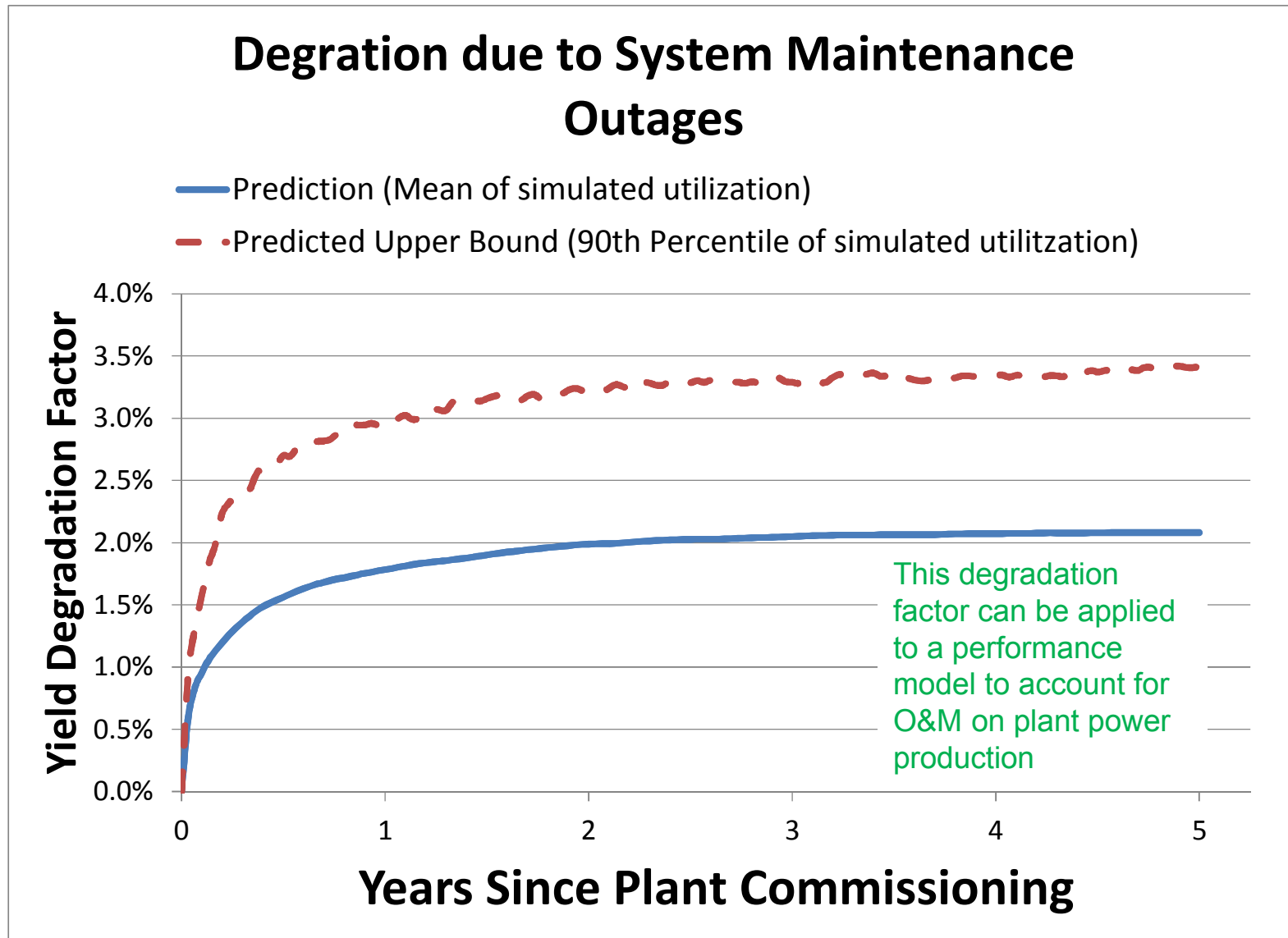

Comparing Warranty vs. No Warranty

	With Warranty (%Labor, %Non-Labor)	Without Warranty (%Labor, %Non-Labor)	Total Failure %	Total Corrective Action Time %	Component Qty
PV Modules & other components	\$2,676.31 (61/39)	\$4,664.59 (71/29)	8.10%	7.78%	4,860 Modules
Inverters	\$7,348.16 (97/3)	\$15,130.13 (94/6)	32.50%	26.15%	4 Inverters
Trackers	\$7,818.47 (95/5)	\$31,323.07 (84/16)	59.40%	66.06%	18 Trackers
<i>Total Cost (Material and Labor)</i>	\$17,842.94 (91/9)	\$51,117.79 (86/14)			

Non-labor cost includes material costs and travel

- Comparative analysis uses synthetic cost data to see the differences in sustainment costs over 5 years
- The initial costs of extended warranties and insurance are not included in this analysis

Other components include: Combiner Boxes, AC Disconnect Switch, High Voltage Transformer, and the Utility Disconnect Switch

Comparisons Of Maintenance Strategies (Measuring Uncertainty)

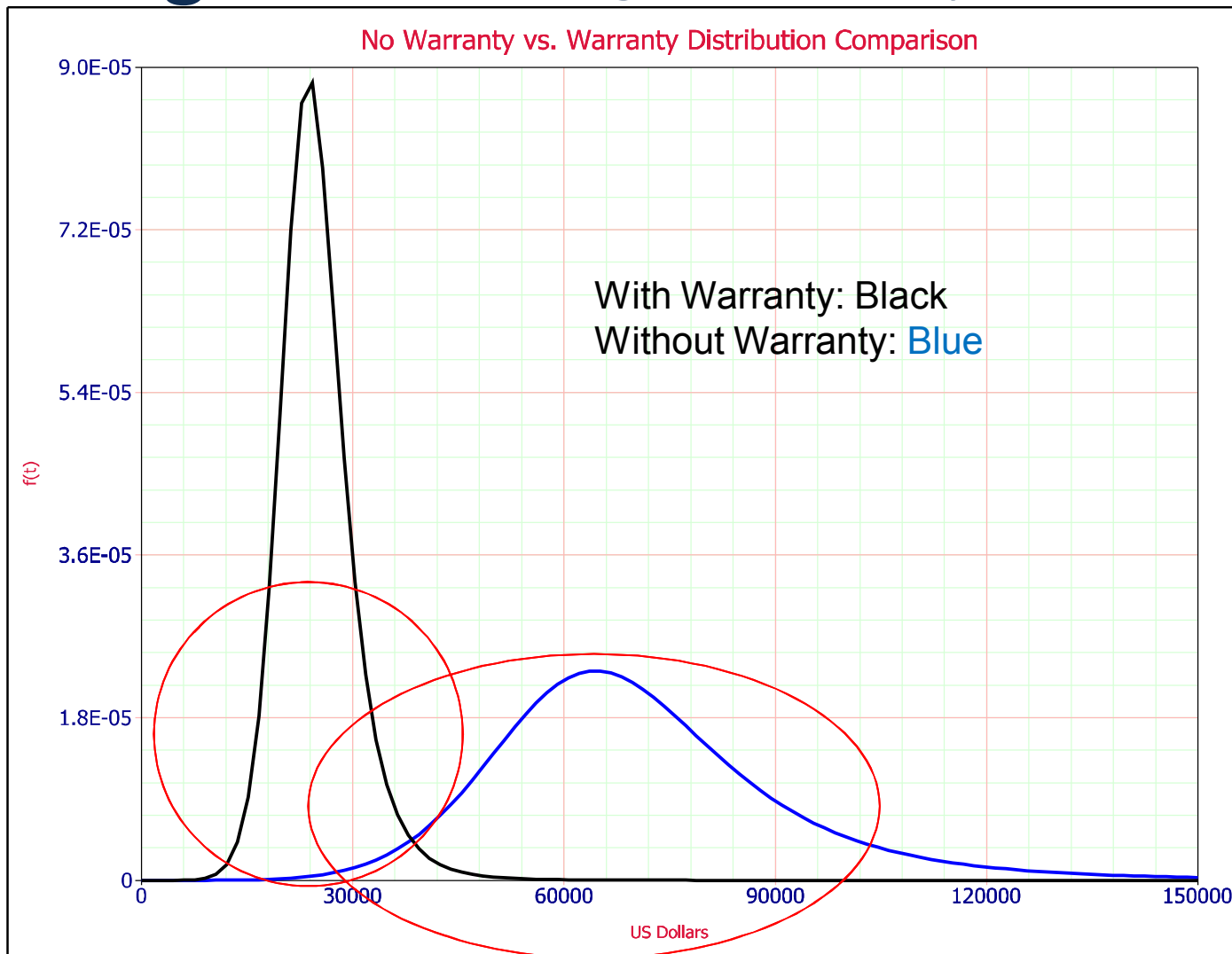

More uncertainty due to variation in maintenance crew skill level and repair times

Less uncertainty with a warranty. We know that the labor and material is covered

Preventative Maintenance Decision

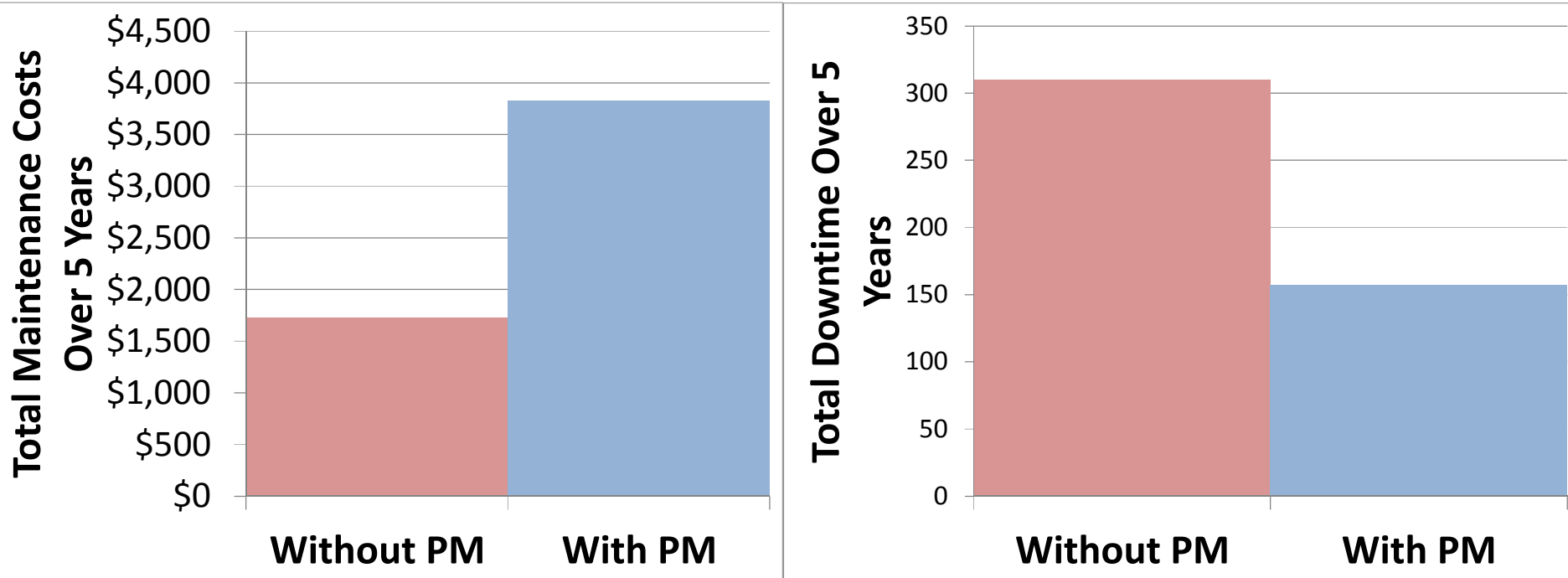

- What is the extra cost of performing preventative maintenance (PM) on a hydraulic cylinder in a single PV tracker?
- Contrast the increased cost to less downtime due to maintenance
 - Added downtime due PM is offset by less corrective maintenance
 - Assumes PM significantly improved hydraulic cylinder reliability

Spares Analysis

- How many spares do we need (on-site or at a depot) to ensure that we are likely not to run out?
- A risk management approach is employed
 - How many hydraulic cylinder spares should we buy to run less than a 10% risk of having no spares?

Year	Expected Number of Failures (in year)	Required Spares (for year)	Risk of Not Having a Spare
1	3.5	6	9.4%
2	18.7	23	9.4%
3	20.1	24	9.2%
4	18.4	22	9.1%
5	19.5	23	9.0%

Recommended spares will vary due to the wear-out failure mode of cylinders

Prediction of O&M Performance

- There are many other comparisons that we can do
 - The impact of location (possible environmental effects)
- Risk Management
 - If we cut back on corrective and preventative maintenance how will it impact our power production?
 - When is the optimal time to replace a component vs. continuing to repair it?
- Ultimately, all decisions can be made from the data itself, but we must have the data!

- Developed to fill a gap in PV performance models
- **Reliability metrics are not accurately included in these models**

Why?

- Fault and Failure Modes in a “*PV System*” are not well understood
- Utilize probabilistic inputs that more accurately represent *actual* faults and failures
 - e.g., Probability of inverter tripping is 30-40% over x number of years, based on a distribution of values
- **PVROM is the basis for developing those distributions along with a better understanding of what causes those faults**
- Within PV-RPM, this data can model performance and cost impacts due to the probabilistic recurrence of this event

GoldSim Player - PV-RPM Demonstration Model v1.1_DP.gsp

Sandia National Laboratories

PV-RPM Photovoltaic Reliability Performance Model

[Home](#) | [Modeling Dashboard](#) | [Failure Modes Dashboard](#) | [Results Dashboard](#)

welcome

The Photovoltaic Reliability and Performance Model (PV-RPM) allows the user to define a PV system (inverters, modules, tracking, etc.) and select or input weather data, and the model will calculate the performance of the system.

The PV-RPM is intended to address more "real world" situations by coupling the performance model with a reliability model so that inverters, modules, combiner boxes, etc. can experience failures and be repaired (or not repaired). This "player" version is intended to demonstrate the system performance and reliability functionality of the PV-RPM using the free GoldSim Player software.

This player file consists of several dashboards that allow the user setup a PV system by specifying the number and type of modules and inverters, chose a site location and weather data inputs, specify module and inverter failure and repair rates, and run a simulation with multiple realizations.

Refer to the included user's guide for more detailed instructions.

This demonstration model is a simplified "player" version of the Photovoltaic Reliability and Performance Model (PV-RPM) currently in development at Sandia National Laboratories (SNL).



Modeling Dashboard [Begin Here >>](#)

The Model Settings dashboard is used to define the basic inputs to the model such as: PV site location and weather data, the modules and inverters from a database, the system setup including tracking and module orientation,



Failure Modes Dashboard

The Failure Modes Dashboard is where the user can specify inputs for the reliability model. The user can select one of two failure mode distributions (Poisson or Bathtub Curve) to represent the failure of modules, and specify the



Results Dashboard

This dashboard shows a number of result output boxes and bar displays that will show real-time values as the simulation progresses. In addition, there are also a number of time history plots that can be viewed after the

34

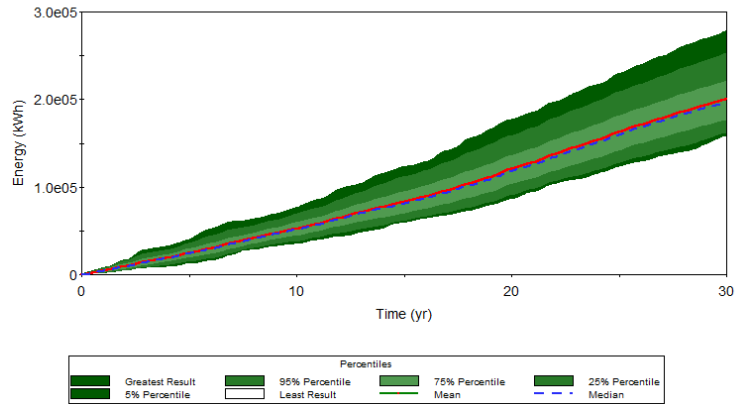

Energy lost over the PV system's lifetime. Large variation over time due to uncertainty

Range of results with 20 'realizations' showing 5th to 95th Percentile bands (least to greatest result)

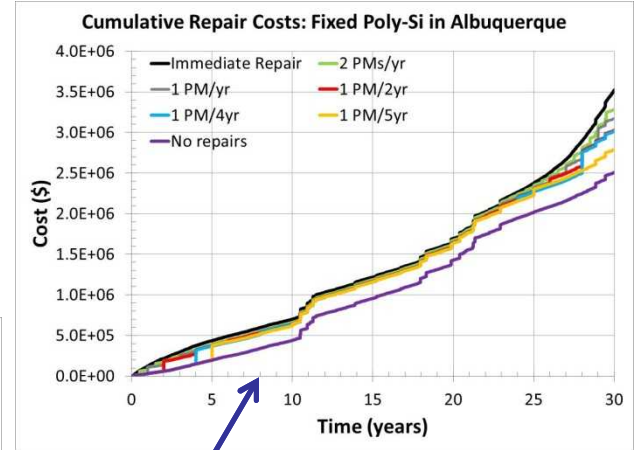

Repair scenarios over time where different preventative maintenance scenarios can be compared.

Results show costs of scenario above, and impacts To energy production below.

Over PV system lifetime, breakdown of all costs. This example reveals ~\$3.5M spent on O&M based on probabilistic inputs

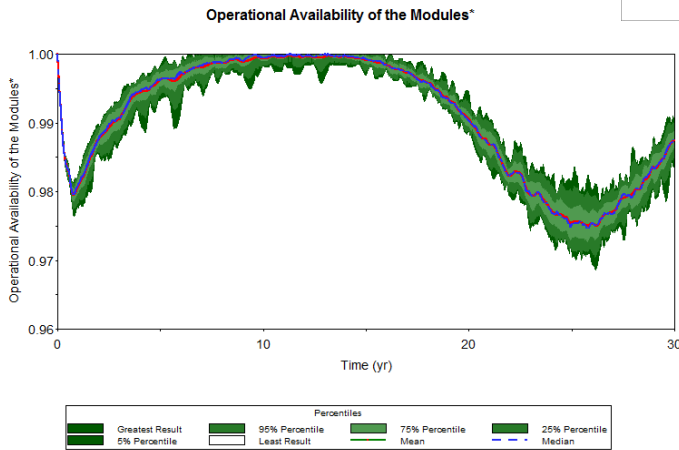
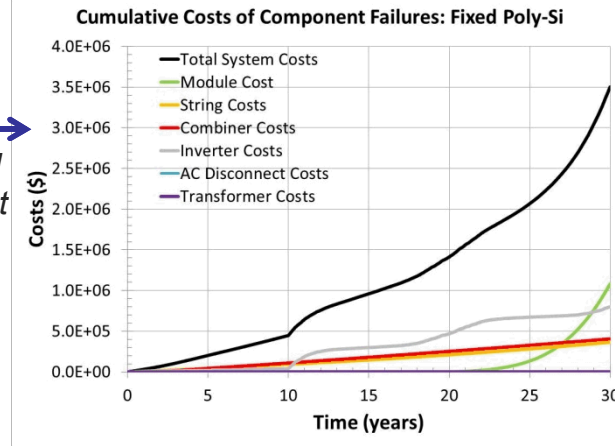

Function of 'bathtub' curve with early wear out, constant failure, then increasing failure

Range of results with 20 'realizations' showing 5th to 95th Percentile bands (Least to greatest result)

