

Exceptional service in the national interest

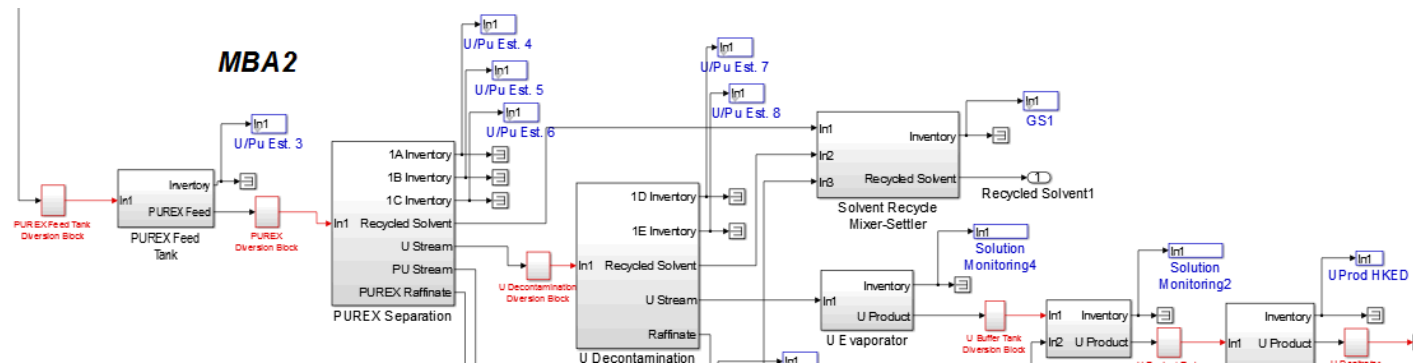

Incorporation of Page's Test in the Separation and Safeguards Performance Model

Ben Cipiti, Mike McDaniel, Tom Burr (LANL)

Overview

- The Separation and Safeguards Performance Model (SSPM) is used for safeguards system design, testing new measurement effectiveness, and diversion scenario analysis.
- The key use of the model is to determine overall detection probability for various safeguards system designs, but this requires a statistical test.
- Page's test is a well-accepted sequential test that is effective for detecting both abrupt and protracted material loss—this presentation describes the incorporation of the test in the MATLAB/Simulink environment.

SSPM Overview

- The SSPM is based in MATLAB Simulink. Currently PUREX, UREX+, and Electrochemical versions exist. Material flows are tracked throughout the plant and measurements are simulated for safeguards.
 - Spent fuel source term library for user-defined runs
 - Mass tracking of elements 1-99, bulk solid & liquid, heat load & activity
 - Integration with SEPHIS (ORNL) and AMUSE (ANL) codes has been applied in the past
 - Customizable measurement points with user-defined measurement error
 - Automated calculation of inventory difference and error propagation in real-time.
 - Alarm conditions and statistical tests
 - User-defined diversion scenario analyses
 - Integration physical protection system analysis.

Simulink Modeling

MBA2

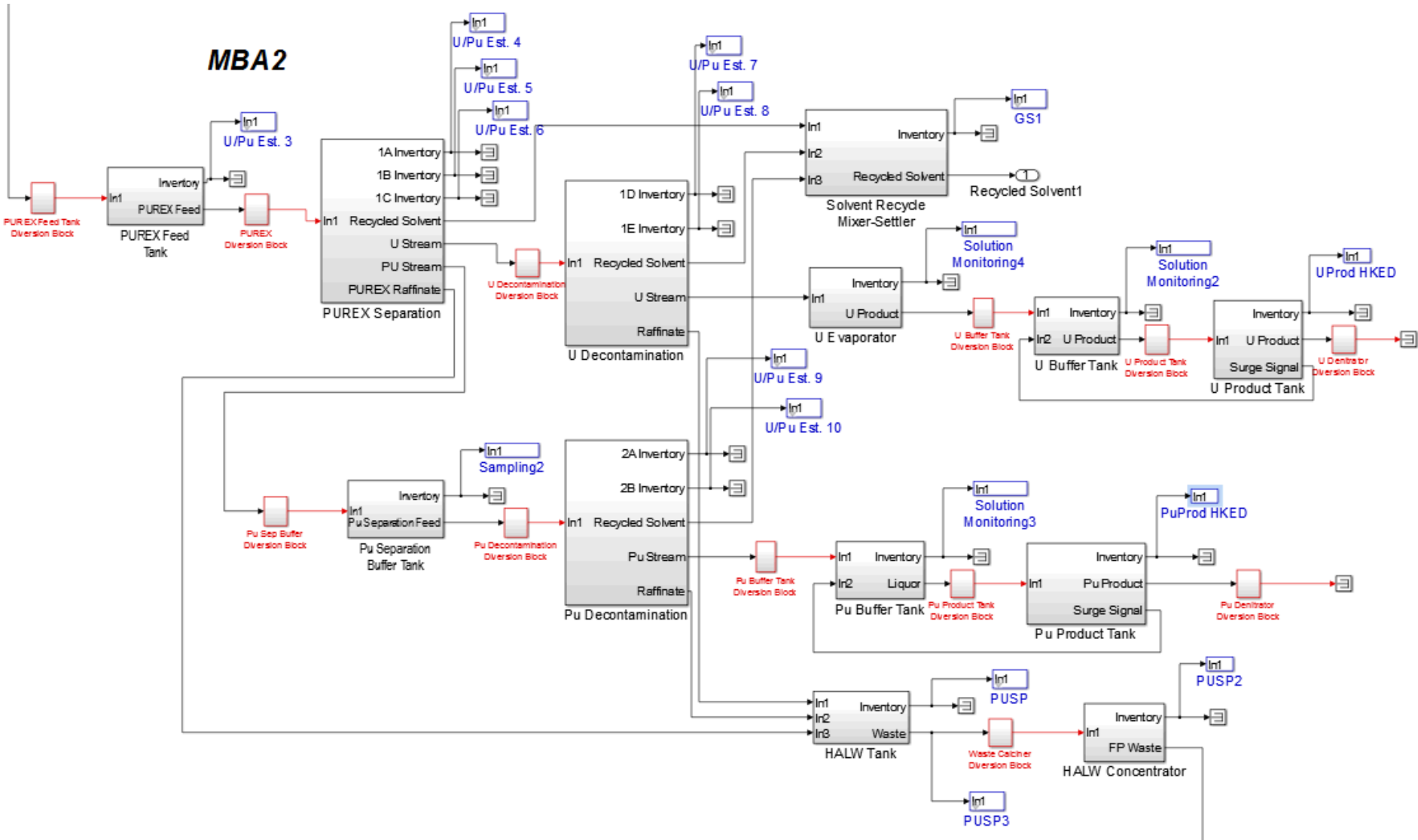

Material Balance Calculation

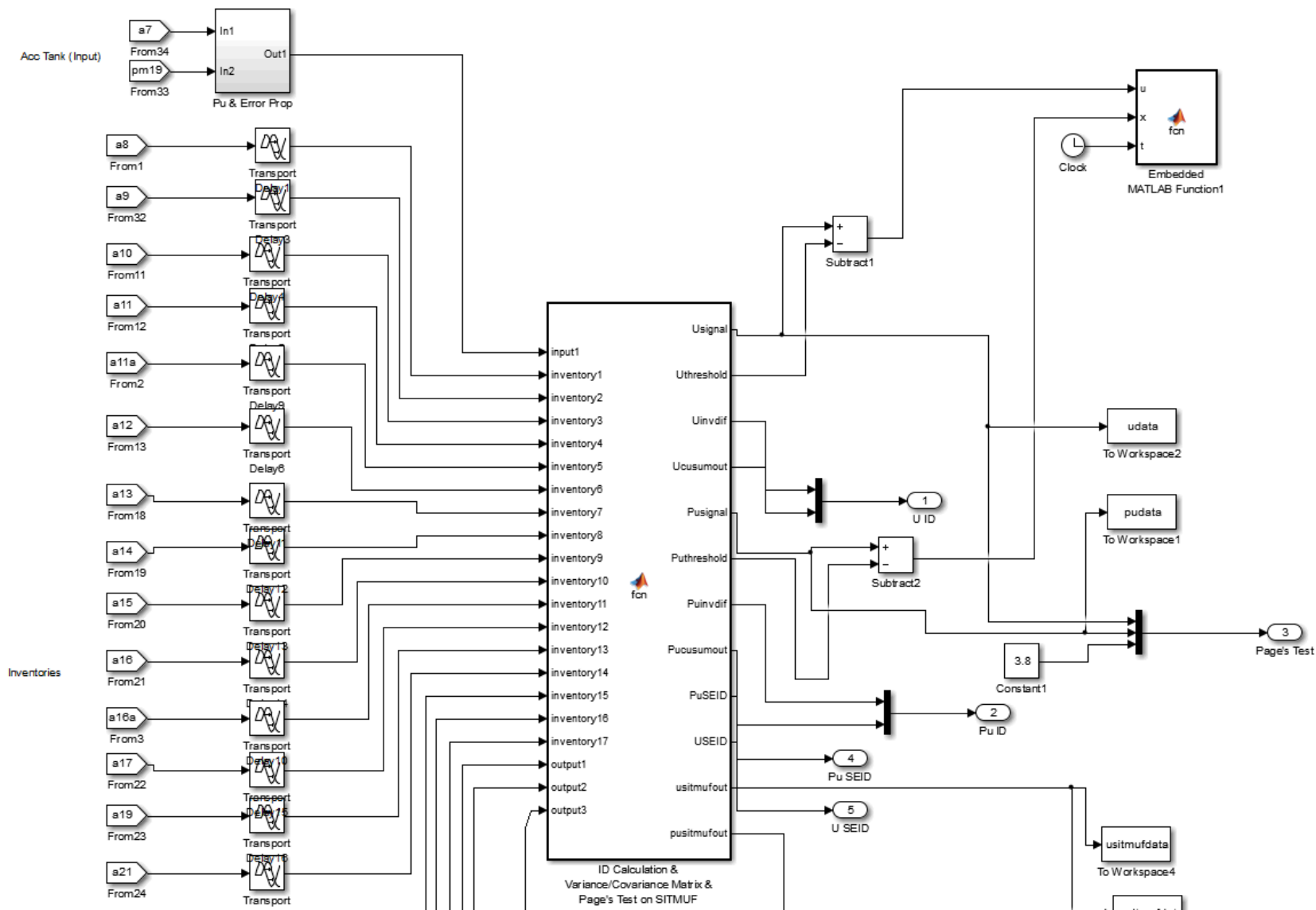

Page's Test of SITMUF

The model has a material balance period appropriate to the facility of interest, for example once every ten days.

The first step is to calculate the Inventory Difference (ID):

$$ID = \sum inputs - \Delta inventory - \sum outputs$$

The standard Page's test assumes statistical independence of each ID value in a series, which is not true in this case. So the ID series is transformed into a Standardized Independent Transformed MUF (SITMUF).

Page's Test of SITMUF (cont.)

An ID series:

$$\overrightarrow{ID} = [ID_1 \ ID_2 \ ID_3 \ \dots]$$

Has a variance/covariance matrix:

$$\begin{bmatrix} V_{11} & C_{12} & C_{13} \\ C_{21} & V_{22} & C_{23} \\ C_{31} & C_{32} & V_{33} \end{bmatrix} \dots$$

There exists a lower triangular matrix [T] and diagonal matrix [U] such that:

$$[T][V][T]^T = [U]$$

The ITMUF [I] is calculated as:

$$[T] \times \overrightarrow{ID} = \vec{I}$$

The SITMUF is calculated as:

$$\overrightarrow{SITMUF} = \frac{\vec{I}^T}{[U]}$$

Page's Test of SITMUF (cont.)

The Page's test is then applied to this SITMUF series. Page's test uses chosen h and k values that are modified to achieve the desired sensitivity and false alarm probability. For this test, $k=0.5$ and $h=5$ are a good starting point. Page's test is calculated at each balance period as:

$$S_1^+ = SITMUF_1$$
$$S_i^+ = \max(S_{i-1}^+ + SITMUF_i - k, 0)$$

An alarm condition is reached when:

$$S_i^+ > h$$

Joint Page's Test

- Previous work by Barry Jones suggested using two tests to monitor for both abrupt and protracted material loss.
- The abrupt test uses a high k value and $h=0$, while the protracted test uses a lower k value and higher h value.
- No diversion cases were run in the model to determine what these values should be for a ten-day balance period. These tests aimed for a false alarm probability of $<1\%$ for the abrupt test and $<4\%$ for the protracted test:

Abrupt: **$k=2.8$, $h=0$**

Protracted: **$k=0.5$, $h=3.8$**

Visualization using Simulink

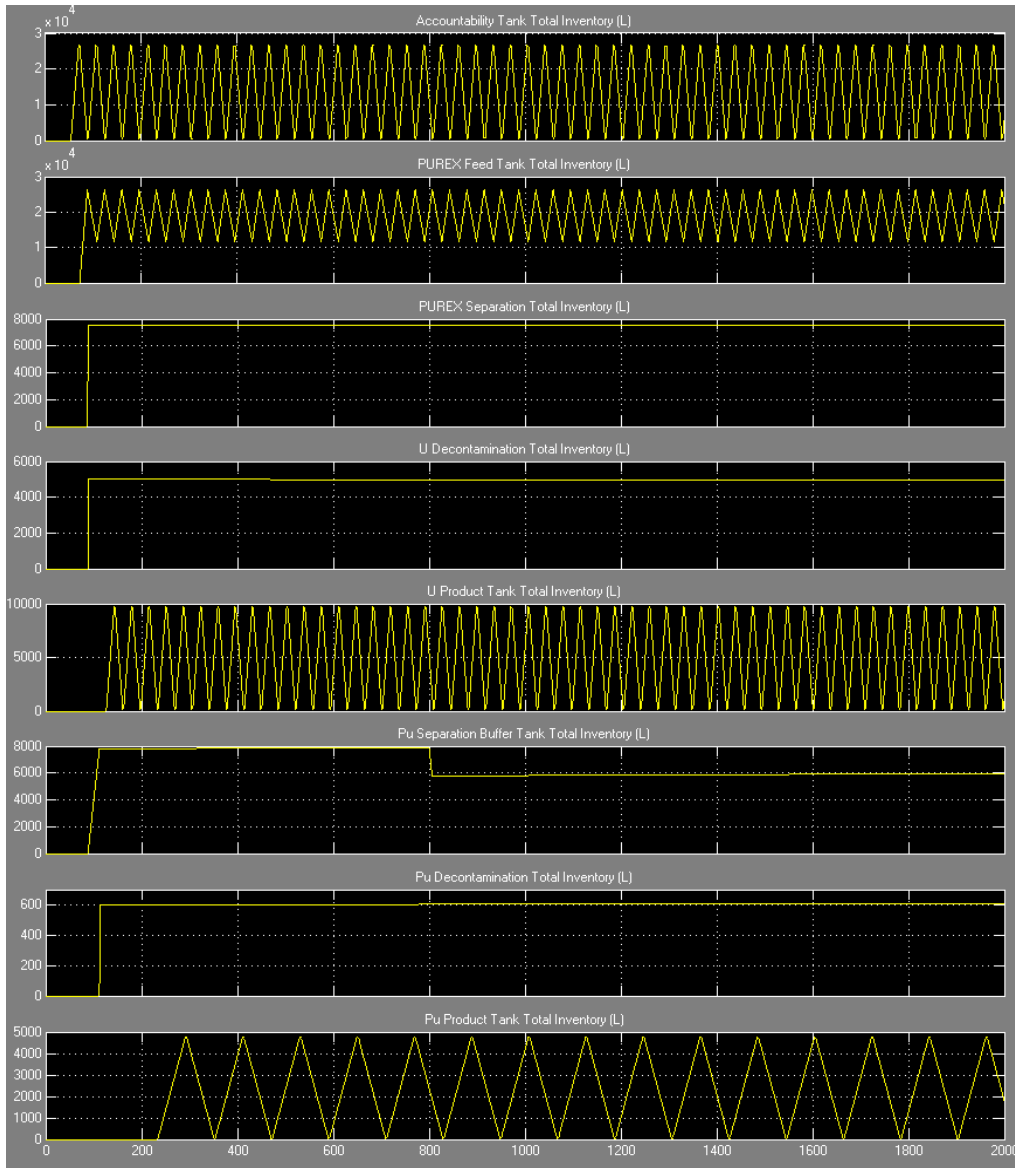

- Example simulation showing the tank inventories from some of the key processing vessels.
- The sixth plot shows a drop in inventory when a material loss was simulated.

Page's Test Example

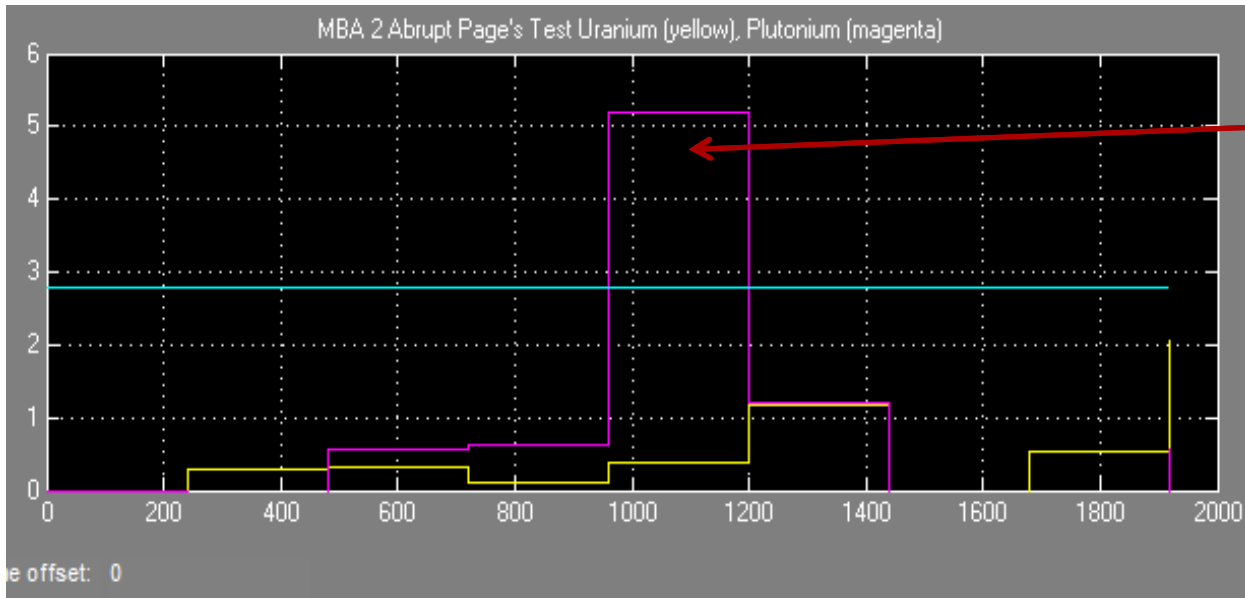

Abrupt test indicated an alarm at hour 960

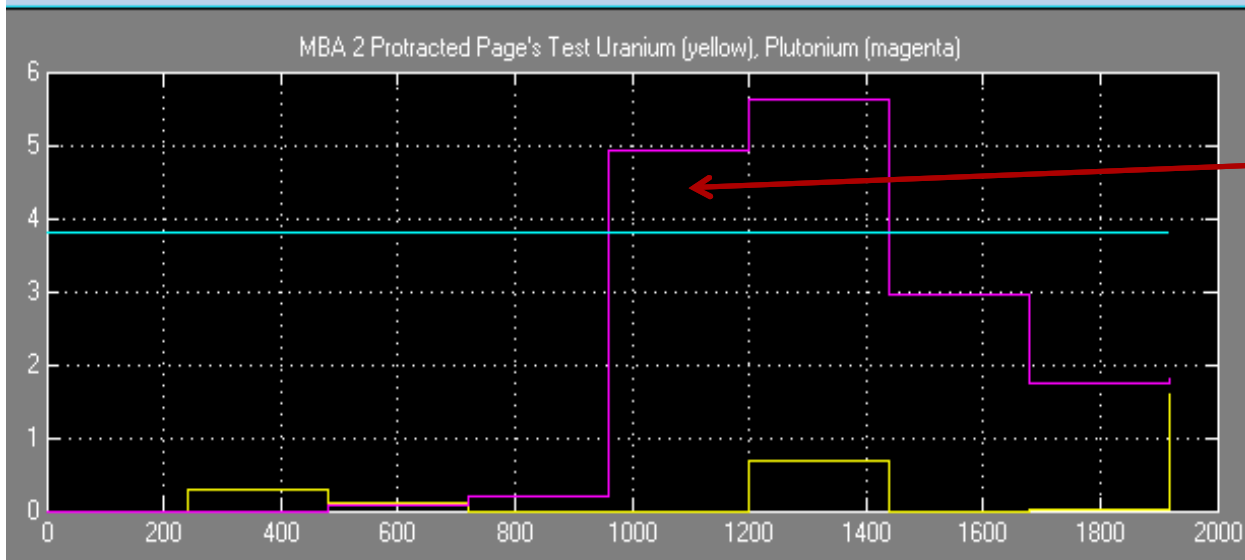

Protracted test also indicated an alarm at hour 960

Discussion

- The Page's test is used to provide the key modeling results for various safeguards studies.
- Recent applications include:
 - Evaluating a new measurement technology (hiRX) for use in existing aqueous plants to improve detection probability (NA-241)
 - Evaluation of cost-effective implementation of process monitoring technologies for aqueous plants—looking at how cheaper instrumentation can provide the same detection to save the operator or inspector time/money (NA-241)
 - Safeguards system design for electrochemical plants, including looking at appropriate balance periods (DOE-NE)

Conclusions

- The full Page's test of SITMUF has been integrated into the SSPM—this provides one of the key safeguards metrics for evaluating new designs or technologies.
- Changes in the programming can be made quickly by modifying the embedded MATLAB code.
- Simulink allows for rapid modifications or development of new models by copying and pasting already existing blocks/subsystems.
- The visualization capability of Simulink provides additional insights into safeguards design.