

Filament Winding



7 May 2014

David Calkins

Packaging and Polymer Processing Department
Materials Science and Engineering Center

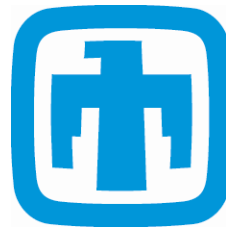

**Sandia
National
Laboratories**

Sandia is a multiprogram laboratory operated by Sandia Corporation, a Lockheed Martin Company, for the United States Department of Energy's National Nuclear Security Administration under contract DE-AC04-94AL85000.

Filament Winding Machines: Export Controls

- **US ECCNs**
 - 1B001, 1B101, 1B201 (different applications)
 - Number of programmable axes and physical dimensions of products are important
- **US ITAR/ML**
 - (Not explicitly controlled)
- **MTCR**
 - 6.B.1 Three or more programmable axes

What is Filament Winding?

- **Process by which continuous reinforcing fibers are accurately positioned in a predetermined pattern to form a shape**
 - **Rovings (many fibers) or monofilaments are used**
 - **Wrapped on a rotating mandrel in a precise manner**
 - **Wetted with a polymer resin to form a composite material**
 - **Cured at room temperature or in an oven**

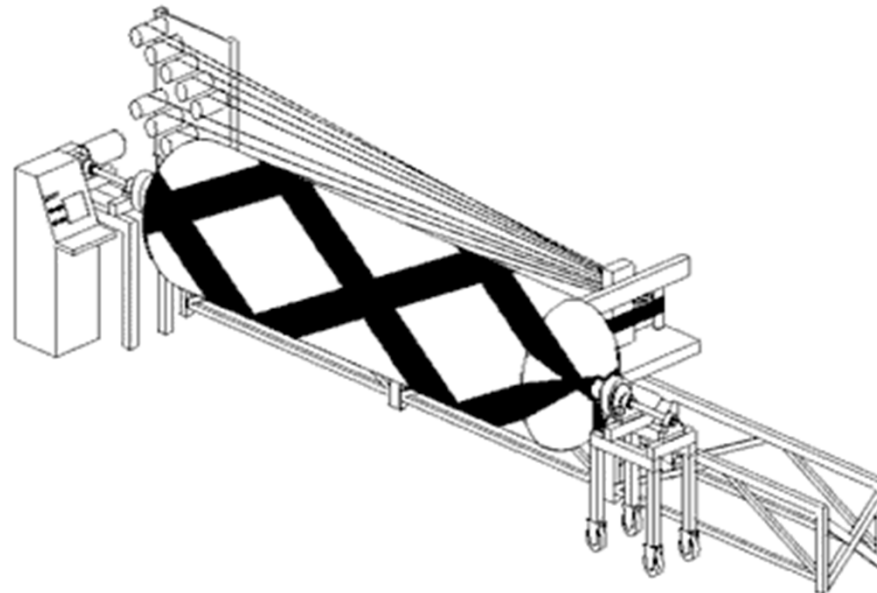

What is a Filament Winder?

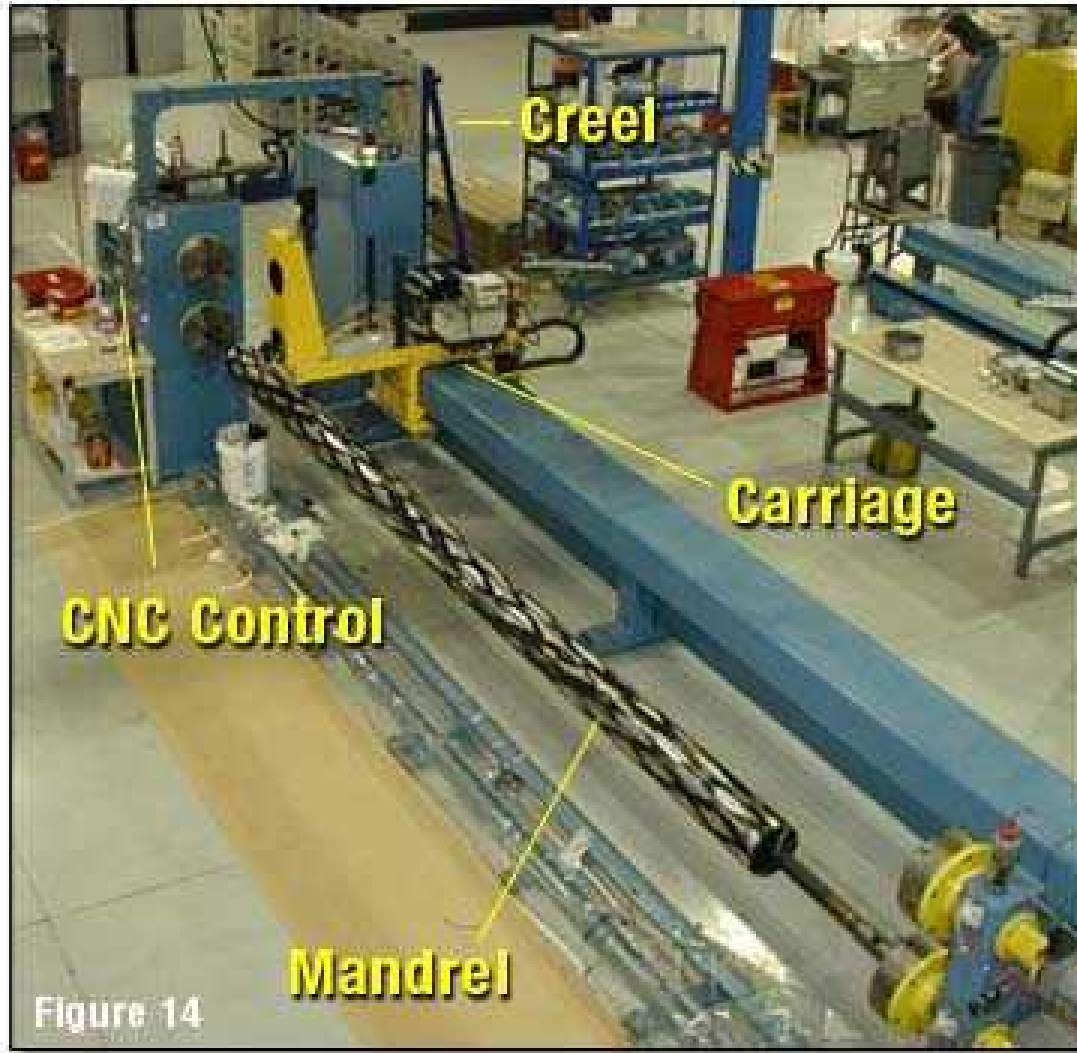

Resin Application

Two main forms of resin application

- **Pre-preg
(fiber pre-coated with resin)**
 - **Advantages**
 - Comes coated in resin
 - Can be used in hand lay-up if needed
 - **Disadvantages**
 - More expensive
 - Storage (low temperature)
 - Cured at elevated temp
- **Resin bath impregnation**
 - **Advantages**
 - Cheaper
 - Easy to store
 - Curable at room or elevated temp.
 - **Disadvantages**
 - Inconsistent
 - Messy

Fiber Wetting/Impregnation

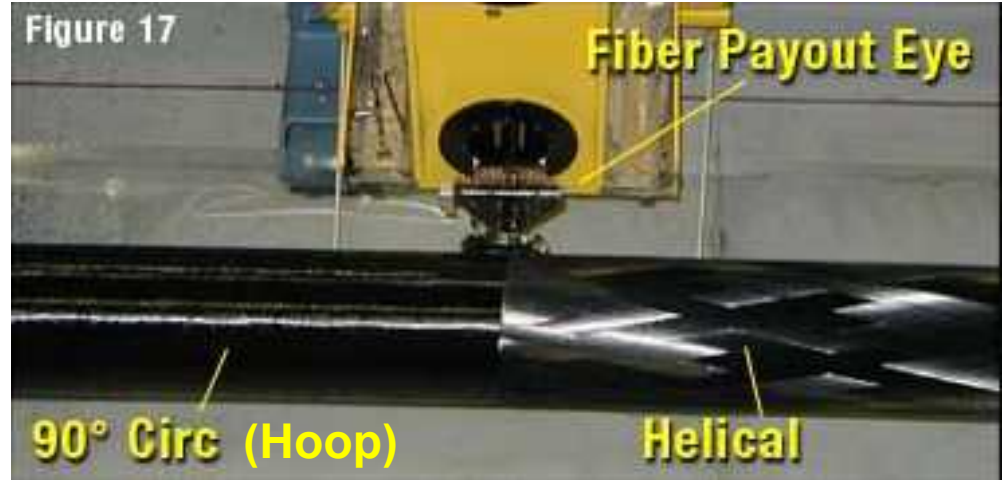

Hoop, Helical, and Polar

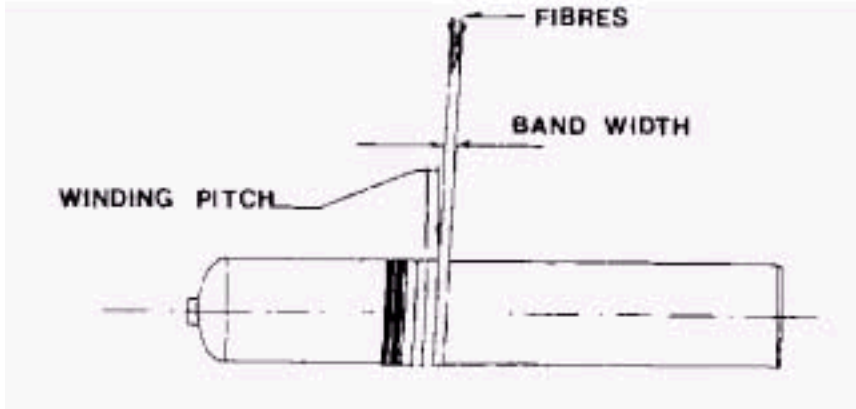

Hoop

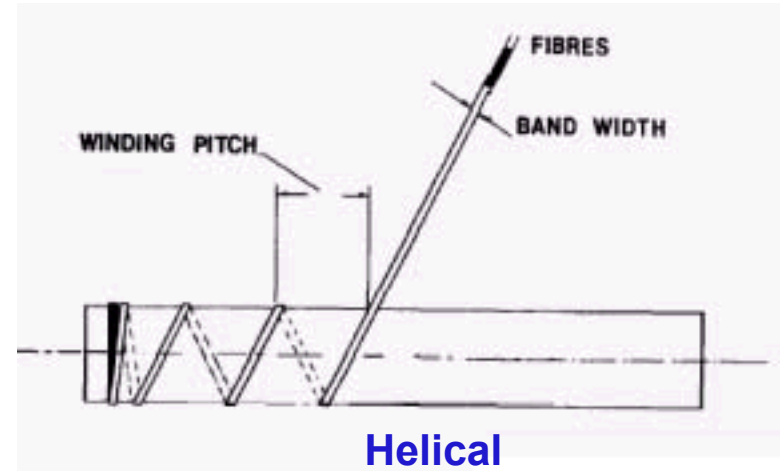

Helical

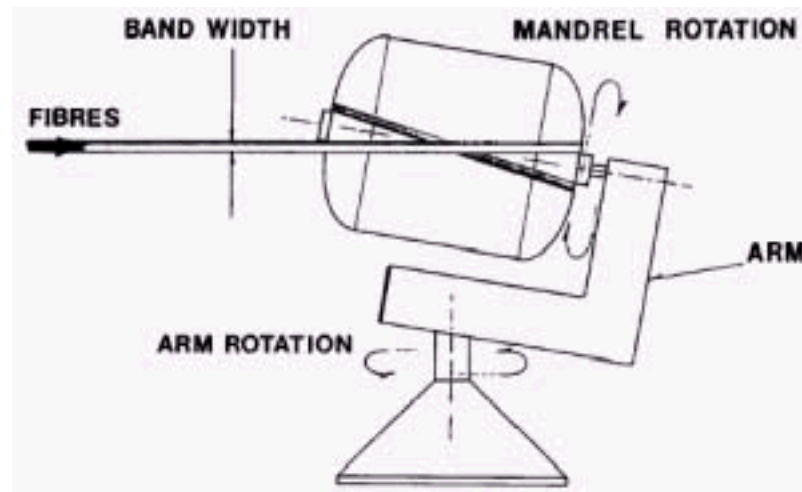

Polar

Why Composites?

- High strength and stiffness per weight
- Reduces the weight of the missile increasing range
- Using sophisticated equipment and processing maximizes the weight savings and allows intercontinental performance



Materials

- **Fibers**

- Graphite
- Glass
- Kevlar

Carbon/Graphite



Fiberglass

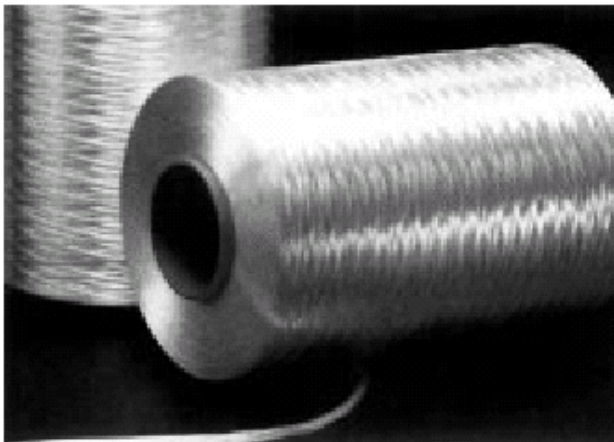

- **Resins**

- Epoxies
- Bismaleimides
- Polyimides
- Phenolics



Kevlar

Filament Wound Examples

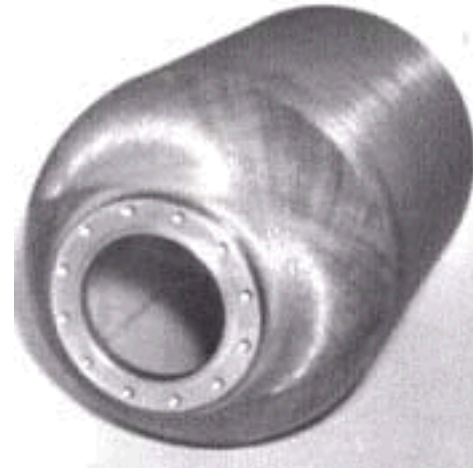
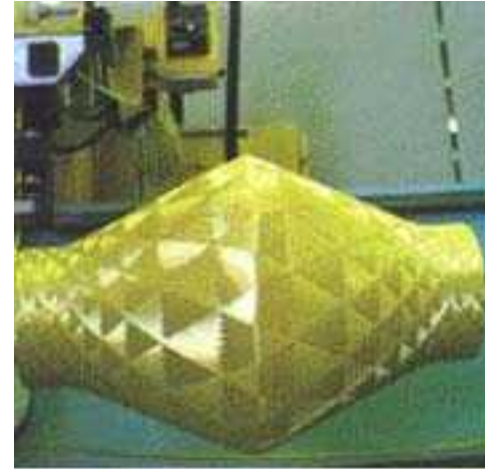

Typical Applications

Industry	Typical Application
Corrosion	<ul style="list-style-type: none"> ▪ Underground Storage Tanks ▪ Aboveground Storage Tanks
	<ul style="list-style-type: none"> ▪ Piping Systems ▪ Stack Liners ▪ Ducting Systems
Oilfield	<ul style="list-style-type: none"> ▪ Piping Systems ▪ Drive Shafts ▪ Tubular Structures
Paper and Pulp	<ul style="list-style-type: none"> ▪ Paper Rollers ▪ Piping Systems ▪ Ducting Systems
Infrastructure and Civil Engineering	<ul style="list-style-type: none"> ▪ Column Wrapping ▪ Tubular Support Structures ▪ Power Poles ▪ Light Standards

Industry	Typical Application
Commercial Pressure Vessels	<ul style="list-style-type: none"> ▪ Water Heaters ▪ Solar Heaters ▪ Reverse Osmosis Tanks ▪ Filter Tanks ▪ SCBA (Self-Contained Breathing Apparatus) Tanks ▪ Compressed Natural Gas Tanks
Aerospace	<ul style="list-style-type: none"> ▪ Rocket Motor Cases ▪ Drive Shafts ▪ Launch Tubes ▪ Aircraft Fuselage ▪ High Pressure Tanks ▪ Fuel Tanks
Marine	<ul style="list-style-type: none"> ▪ Drive Shafts ▪ Mast and Boom Structures
Sports and Recreation	<ul style="list-style-type: none"> ▪ Golf Shafts ▪ Bicycle Tubular Structures ▪ Wind Surfing Masts ▪ Ski Poles

Who Manufactures Winders?

- **Companies in many countries**
 - **France**
 - **Germany**
 - **Italy**
 - **Japan**
 - **Netherlands**
 - **Russia**
 - **United Kingdom**
 - **United States**

Filament Winding Machines: Vulnerability to Diversion

- Commercial products made by filament winding of comparable dimensions to missile components include tanks, pipes, and utility poles
 - These applications typically are less demanding and do not require high-end machines
- Be suspicious of high-performance machines for low-requirement applications

Poor Man's Filament Winder

- A large machining lathe can be easily adapted
- Build your own rotation system, feed the fiber by hand, brush on the resin by hand
- India indicates they designed, developed, fabricated and installed a 4-axis filament winder in 8 months

Questions?

