

## POLARITY INVERSION ON SATURN

**V. J. Harper-Slaboszewicz, K. A. Mikkelson**

*Sandia National Laboratories*

*PO Box 5800*

*Albuquerque, NM 87185*

**B. V. Weber, D. P. Murphy, R. J. Comisso**

*Naval Research Laboratory*

*Washington, DC 20375*

**J. R. Goyer, J. C. Riordan**

*L-3 Pulse Sciences*

*2700 Merced St*

*San Leandro, CA 94577*

### *Abstract*

Saturn is a pulsed power accelerator consisting of 36 parallel modules producing 10 MA at 1.7 MV in a 40 ns power pulse[1]. Saturn is built to operate in negative polarity. Two methods of inverting the polarity in vacuum and driving up to 2.5 MA into a triplate MITL with a low impedance load have been built and demonstrated. Both rely on the use of a ballast inductance to invert the polarity[2]. The first method uses a dual post-hole convolute while the second method uses no convolutes.

### **I. Background**

The construction of the Saturn accelerator provides great flexibility for reconfiguring the power flow. Any number of the 36 lines can be easily bussed out to reduce the total current. Each of the 36 lines is connected to the vacuum stack by two rods. Up to 36 rods can be connected to the lower and middle cathode rings, and up to 24 rods can be connected to the upper anode ring. Shaped rods can be used to tailor the drive impedance, and special "combo" rods can be used to put the full drive on a line onto a single cathode ring. The vacuum stack is 6 feet in diameter, and the drive is taken to the load using nested conical plates forming magnetically insulated transmission lines. Not all of the plates need to be installed, and their vertical positions can be adjusted to adjust the line inductance. Large vacuum volumes are available above and below the transmission lines. All of these features were used in the polarity inversion experiments described here.

### **II. Dual post-hole convolute method**

One standard operating mode of Saturn is designed to drive z-pinch loads. The vacuum section is configured with two cathode plates and three anode plates, forming two triplate transmission lines. Half of the rods are connected to each of the two cathodes. Using a post-hole convolute with the posts on a 6 inch diameter circle, the drive is converted to a converging parallel plate transmission line, which then turns the corner into a coaxial geometry to drive a small diameter z-pinch load.

#### *A. Design*

Recently a 12-inch diameter convolute to drive a large diameter z-pinch load has been constructed. To invert the drive polarity, this convolute was connected to a coaxial line just inside the convolute diameter. At the end of the line, the corner was turned again into a parallel plate line. The driven plate was connected to ground through a large ballast inductance of about 130 nH to invert the drive polarity. The skin depth isolates the fields on the interior of the ballast inductor from the outside, so the outer surface of the ballast inductor remains at ground potential. Another post-hole convolute was used to convert the parallel plate line to a triaxial line, this time with the inner and outer conductors connected to the driven plate, and the central conductor connected to the undriven plate. This triaxial line was used to drive a low impedance bremsstrahlung load. This geometry is illustrated below.

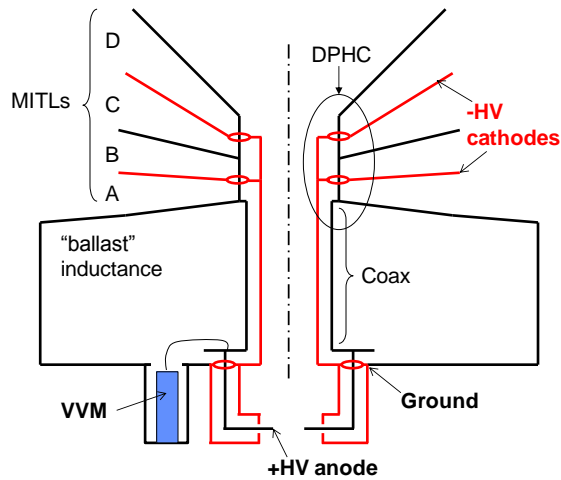

**Figure 1.** Schematic of dual post-hole convolute method for inverting polarity in vacuum. The vacuum voltmeter (VVM) was used to verify the polarity inversion.

### B. Experimental Results

The experiments were extensively diagnosed, with B-dot current monitors in the MITLs outside the diameter of the upper post-hole convolute, at the top of the coaxial section inside the upper post-hole convolute, and on both the inner and outer lines of the lower triaxial section below the lower post-hole convolute, as well as on the ballast inductance.

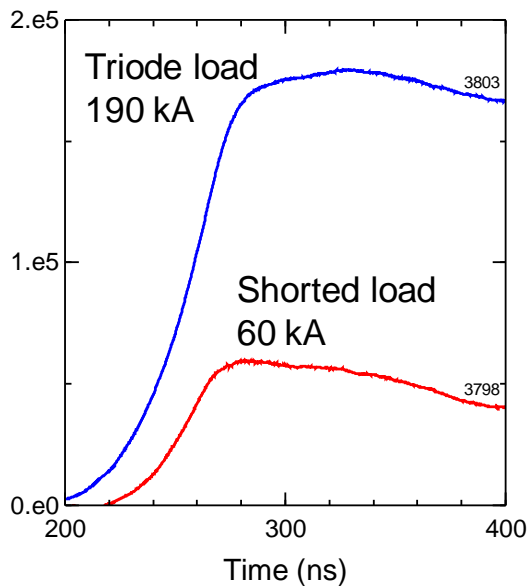
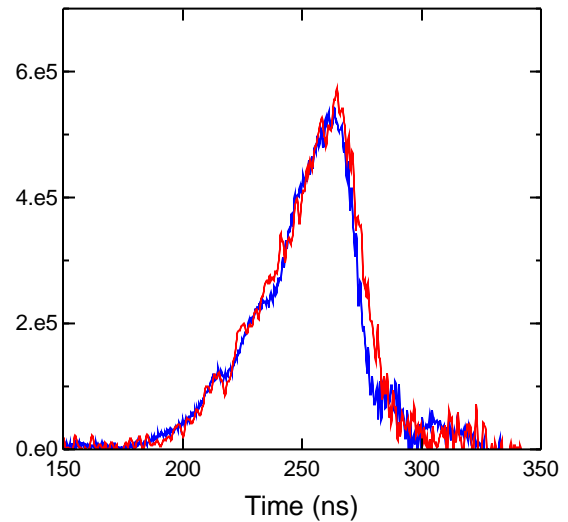

**Figure 2.** Ballast current for dual post-hole convolute with shorted and low-impedance loads.

Figure 2 shows the measured ballast current for both a shorted load and a low-impedance radiation load. As the load impedance increases, the ballast inductor current increases. On these shots, the total current was about 4 MA, so only a small fraction, totaling 3% for the short circuit load and 10% for the triode load, of the current flows in the ballast inductor.

Figure 3 shows that the voltage with respect to ground of the central conductor of the lower triaxial line is indeed positive, and is precisely as expected from the ballast inductance and current. Note that the trailing edge of the voltage pulse is truncated, likely due to a breakdown in the drive as the current was shunted somewhere along the drive path.

During this experiment series the rods were configured to drive total currents from 1 MA to 6 MA. Figure 4 shows the current in the MITLs outside the posthole convolute for a shot in the middle of this sequence. At all drive levels there were significant current losses between the MITLs and the load, apparently at the post-hole convolutes based on the observed damage. However, this configuration was able to drive about 2 MA into a 1 MV load, which met the load drive requirements.



**Figure 3.** The red line shows the measured voltage from the VVM. The blue line shows the inductive voltage calculated from the inductance of the ballast inductor and the measure rate of change of the current in the ballast inductor.

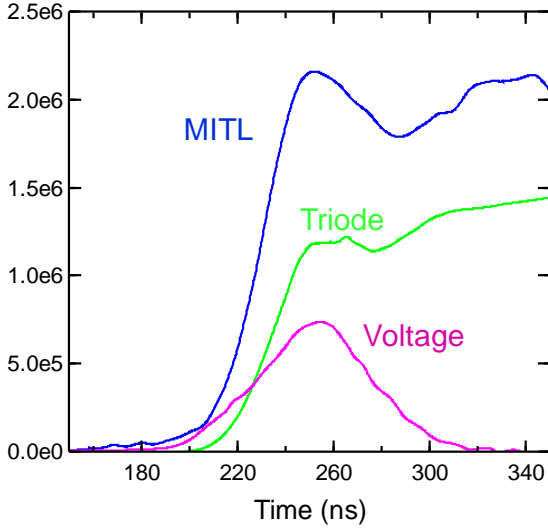

**Figure 4.** Measured currents in the MITL outside the post-hole convolute and in the load region. The measured voltage at the second convolute is also shown.

The experiments demonstrate that this geometry does invert the polarity in vacuum and can provide the required drive to the load. However, current losses limit the potential for scaling up this geometry to higher currents.

### III. Convolute-free method

The use of the post-hole convolute enables the previous method to invert the polarity at a single point, providing a consistent drive voltage to both sides of the triaxial line to the load. The penalty is that the post hole convolute, with its associated power losses and mechanical complexity, is required to provide this single point drive.

#### A. Design

To avoid the use of the convolute, two separate ballast inductors are used to invert the polarity of the inner and outer conductors of the triaxial line that drives the load. To keep the voltage on the two conductors equal, the ballast inductances are matched by adjusting the line geometry.

In this configuration the upper and lower ground plates of the z-pinch drive configuration are not used, and the connection to the ballast inductance is made at about 24 inch diameter on the upper and lower conductors as shown in Figure 5.

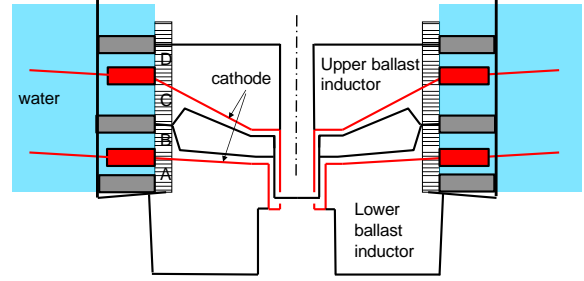

**Figure 5.** Schematic of the convoluteless method for inverting the polarity of a triaxial drive in vacuum.

One of the issues with this geometry is that the grounds paths are significantly more complicated than on the convolute geometry, and determination of the voltage at the load requires more inductive corrections. Two VVMs are required for the two lines, in addition to the MITL, load, and ballast current monitors. V-dot monitors in the water sections were used to monitor not only the drive voltages but the voltage changes on the “ground” lines. These are shown in Figure 6.

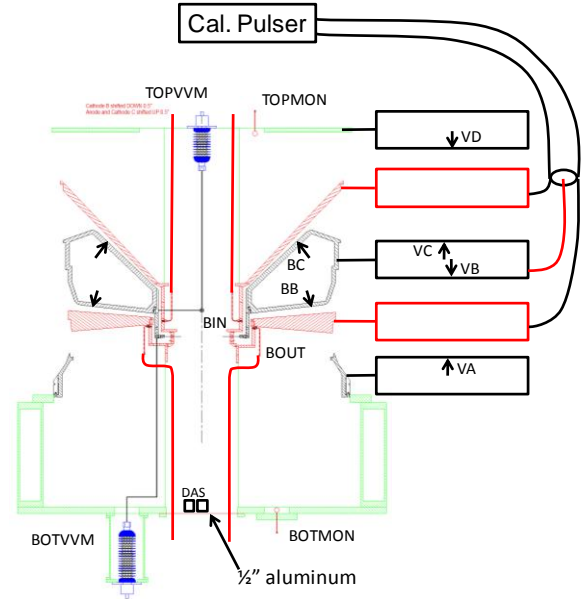
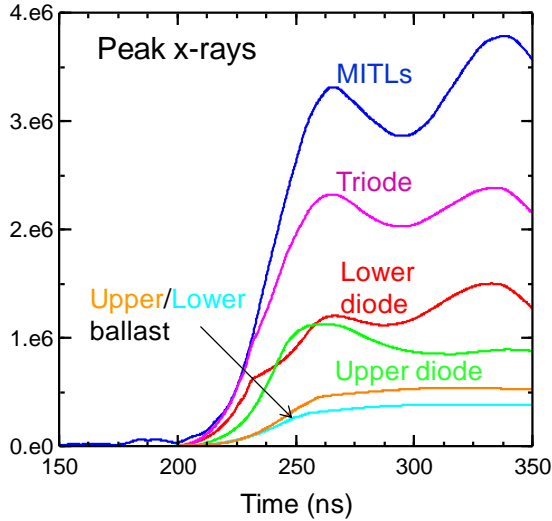

**Figure 6.** Calibration setup and diagnostics for convoluteless power flow.

#### B. Experimental Results

Experimental results for the convoluteless power flow are shown in Figure 7. Clean signals were obtained from most of the current monitors. The loss currents in the upper and lower ballast inductors were well balanced, so the voltages should have been similar. The currents in the two lines near the diode were also well matched. There is still apparent current loss between the MITLs and the load,

although there was almost no damage observed in that power flow region. Whatever losses are present must be distributed.



**Figure 7.** Currents for convoluteless polarity inversion.

The voltage signals are not nearly as clean. As shown in Figure 8, the voltage signal shows low frequency structure not present in the current or power signals. The source of this noise is not clear, but may be related to the inductive voltage corrections required in this setup.

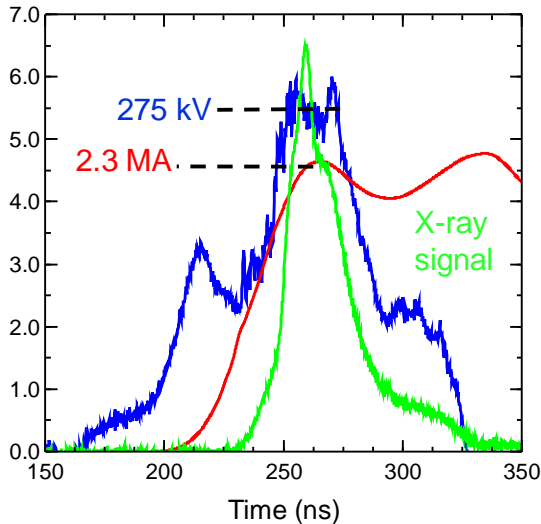

**Figure 8.** Corrected voltage, current, and x-ray signal (proxy for diode power) for convoluteless polarity inversion.

It should be noted that in this configuration, the power signal (as suggested by the x-ray signal) has a

long tail. This differs from the dual post hole convolute case, for which Figure 3 shows a rapid drop-off in the tail of the signal. This difference suggests that the power flow is not truncated in the convoluteless polarity inversion scheme.

#### IV. Conclusion

Two methods of inverting the power flow in vacuum and driving 2-2.5 MA into a triaxial load have been built and demonstrated. In the dual post-hole convolute method, a clean and easily interpreted voltage measurement is available at the second convolute, but the power flow is truncated late in time by convolute losses. In the convolute free method, voltage measurements are more difficult, but the power flow appears to be more stable, with no late-time truncation of the power pulse.

#### V. References

- [1] Bloomquist, D.D., Stinnett, R.W., McDaniel, D.H., Lee, J.R., Schlitt, L.G., Spence, P.W., Corcoran, P.M., Sharpe, A.W., Halbleib, J.A., "Saturn, a large area x-ray simulator", 6<sup>th</sup> IEEE Pulsed Power Conference, June 29- July 1, 1987.
- [2] Faraday, M. "Experimental Researches in Electricity", Phil. Trans. R. Soc. Lond. 122:125-162, Jan 1, 1832.