



Perturbation Decay Experiments on Granular Materials

Tracy J. Vogler

**TMS Conference
February 20, 2014
San Diego, California**



Sandia National Laboratories is a multi-program laboratory managed and operated by Sandia Corporation, a wholly owned subsidiary of Lockheed Martin Corporation, for the U.S. Department of Energy's National Nuclear Security Administration under contract DE-AC04-94AL85000.





Sakharov et al. Perturbation Decay Experiment

Sakharov, A. D., R. M. Zaidel, V. N. Mineev and A. G. Oleinik (1965). "Experimental investigation of the stability of shock waves and the mechanical properties of substances at high pressures and temperatures." *Soviet Physics JETP* 9: 1091-1094.

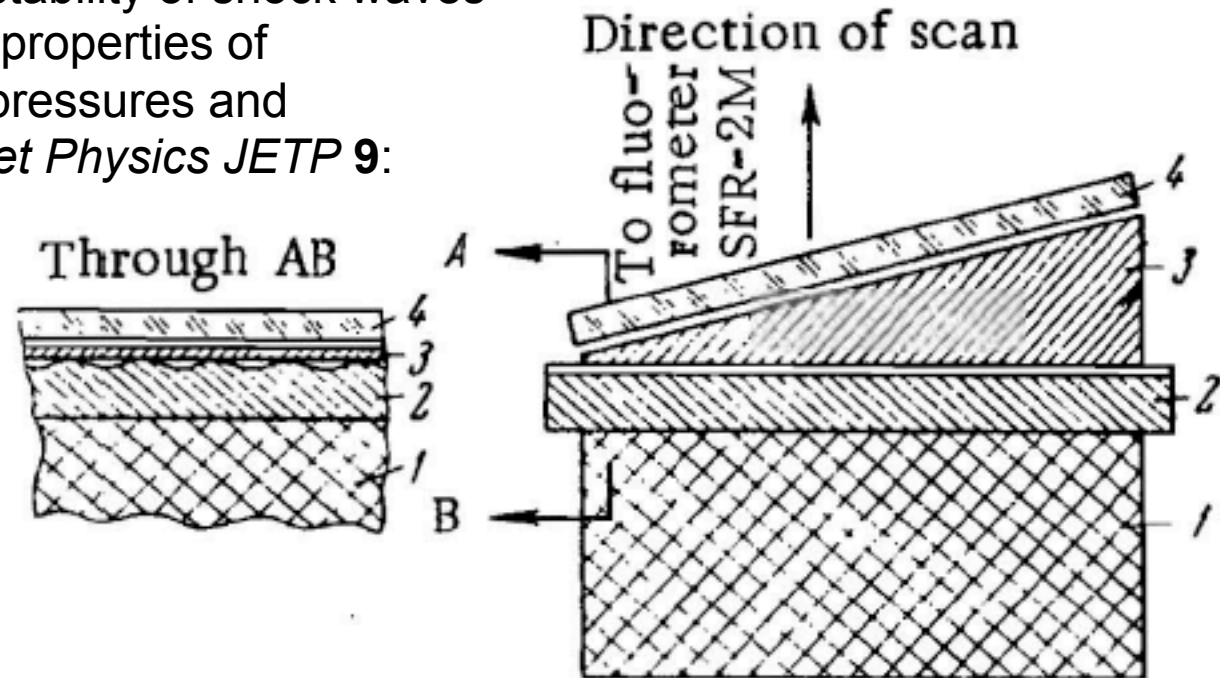
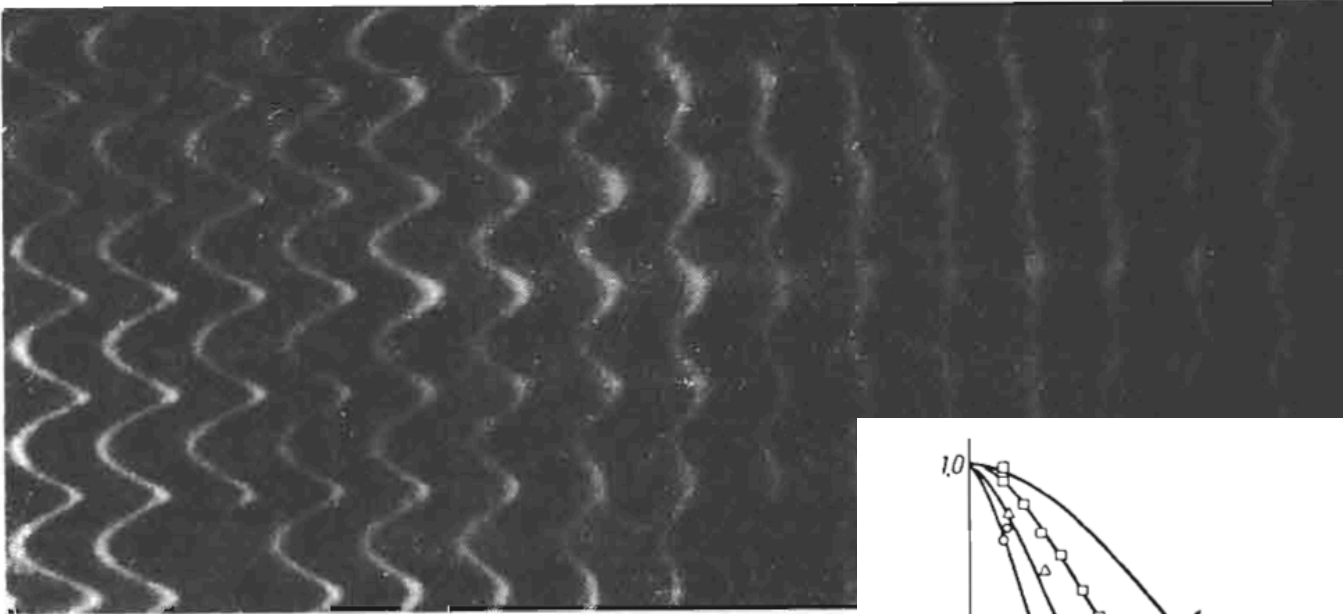

Fig. 1. Diagram of experimental arrangement:
1) Explosive charge; 2) grooved disc; 3) wedge;
4) plastic plate.



Measured Perturbation Decay



*why no work of
this type in the
west?*

- tested solids (e.g. Al) and liquids
- viscous fluid analysis
- boundary conditions problematic

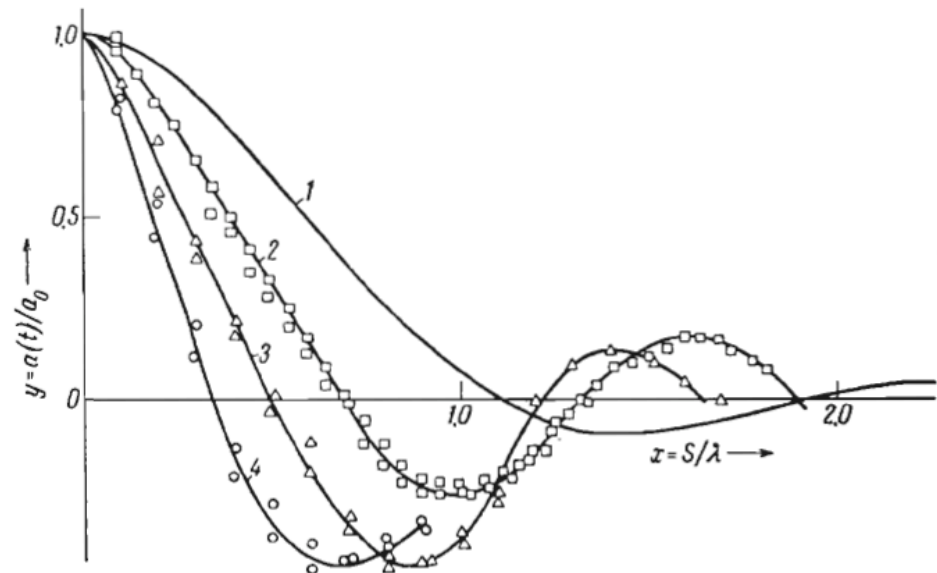

Fig. 3. Some experimental curves of the development of perturbations at a shock-wave front. 1) Calculated curve; 2) $\lambda = 2$ cm; $ka_0 = 0.872$; 3) $\lambda = 1$ cm, $ka_0 = 0.872$; 4) $\lambda = 1$ cm, $ka_0 = 1.74$.



Recent Chinese Studies

Ma, X., F. Liu, M. Zhang and Y. Sun (2011). "Viscosity of aluminum under shock-loading conditions." *Chinese Physics B* **20**: 068301.

Li, Y., F. Liu, X. Ma, Y. Li, M. Yu, J. Zhang and F. Jing (2009). "A flyer-impact technique for measuring viscosity of metal under shock compression." *Review of Scientific Instruments* **80**: 013903.

Ma, X., F. Liu, Y. Sun, M. Zhang, X. Peng and Y. Li (2011). "Effective shear viscosity of iron under shock-loading condition." *Chinese Physics Letters* **28**: 044704.

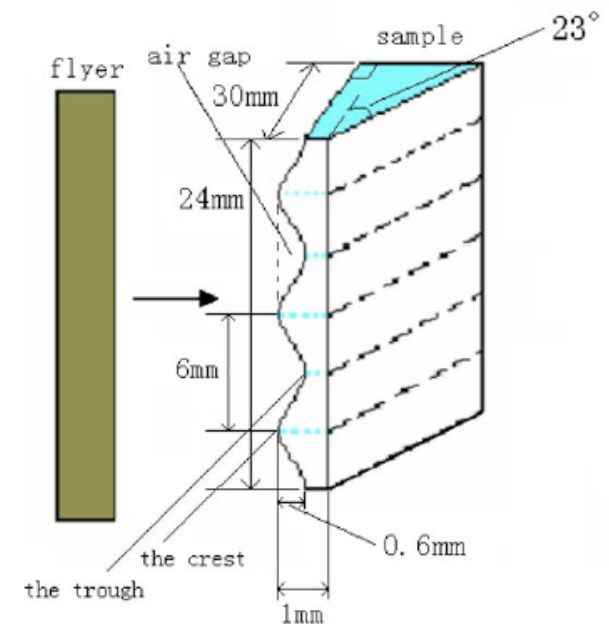
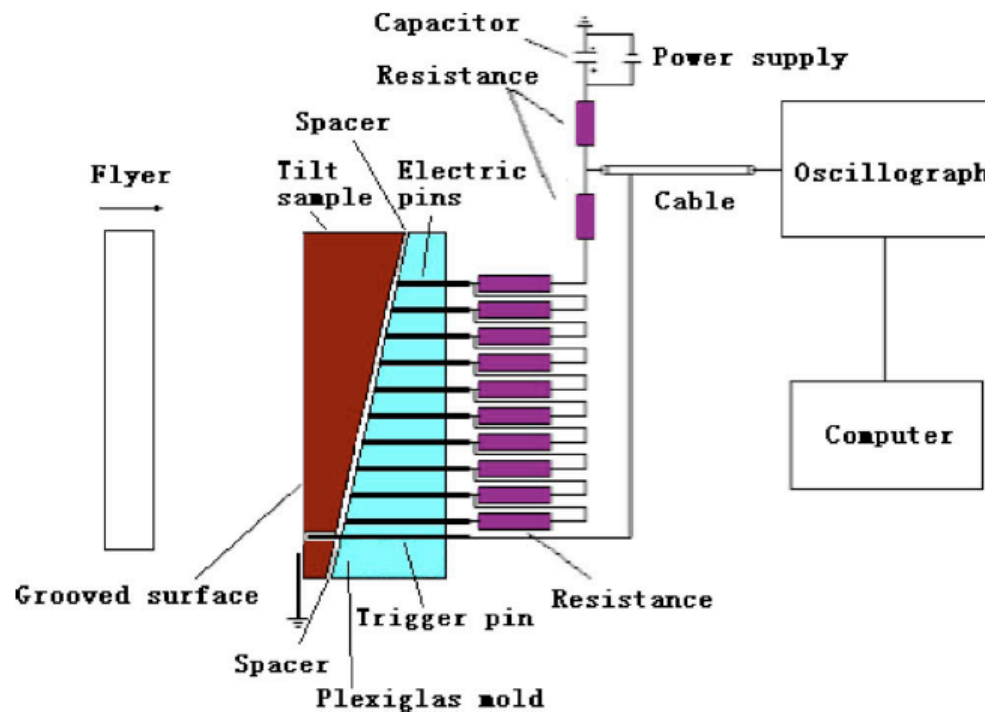

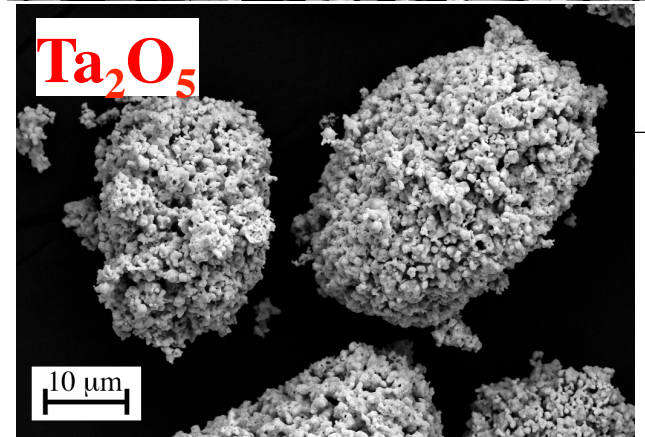
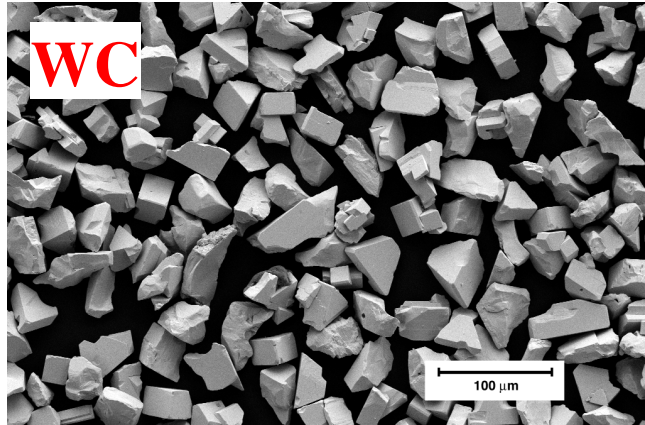

Mesoscale Modeling

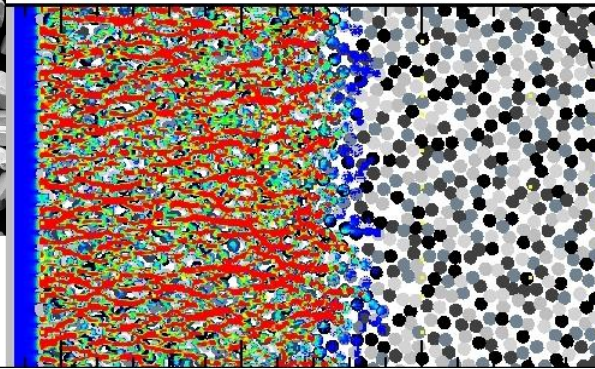

Planar Impact

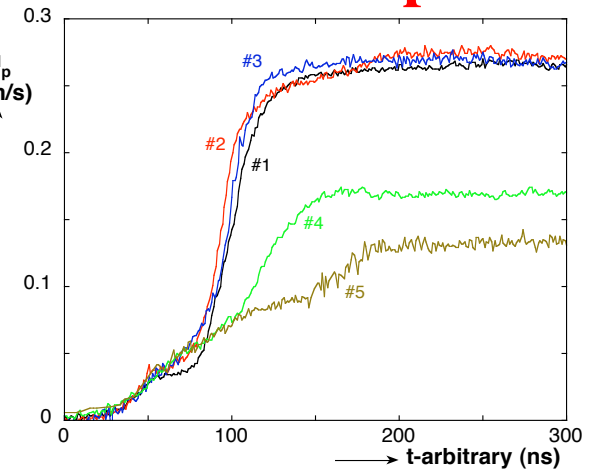

Pressure-Shear

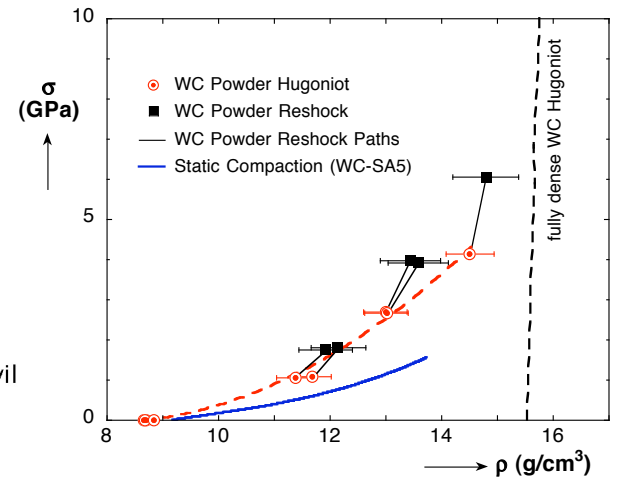
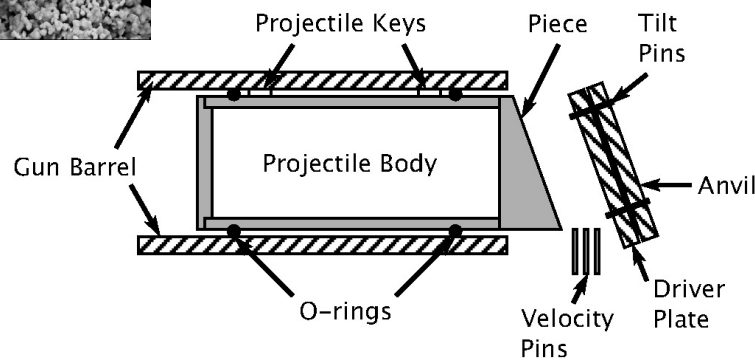



Continuum Simulations

- performed with CTH
- symmetry BC at top and bottom
- aluminum impactor and driver with sinusoidal perturbation
- granular WC (gray) modeled with P- λ compaction description (calibrated to planar impact shots) and a strength model
- wave propagates in sample and perturbation decays
- $\sigma \sim 5$ GPa for 874 m/s impact

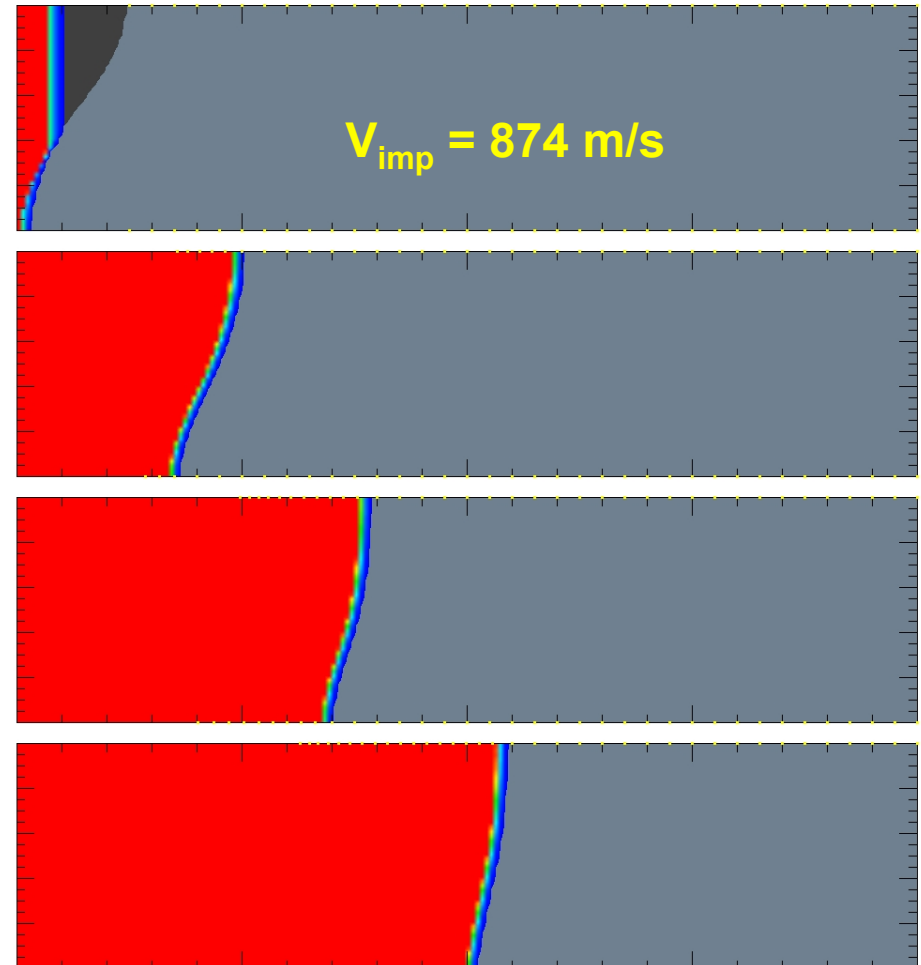



Continuum Simulations

**movie from
874 m/s simulations**



Continuum Simulation Results

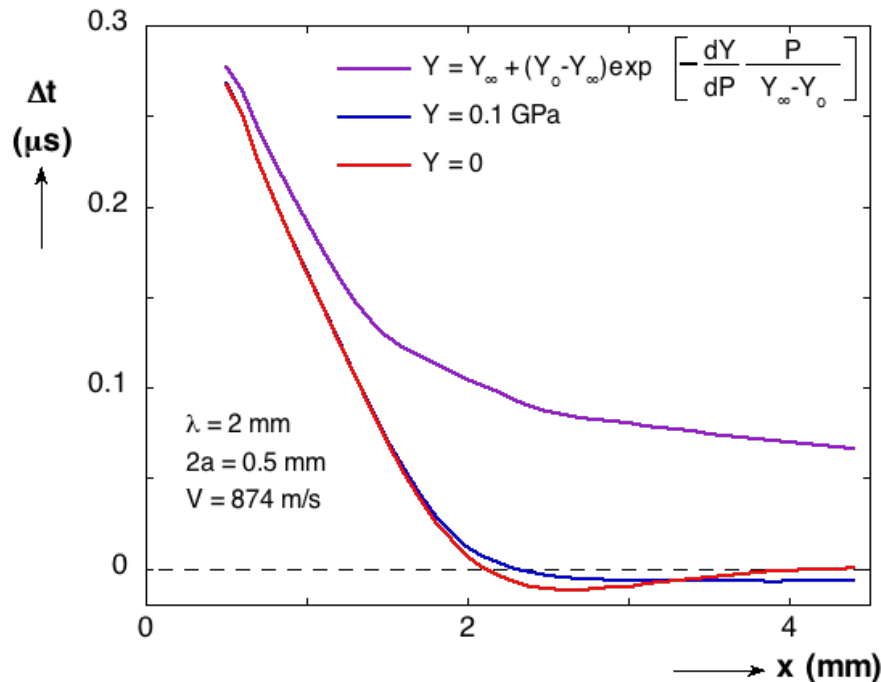

- consider three strength models:
 - $Y=0$
 - $Y=0.1$ GPa
 - pressure-dependent strength calibrated from pressure-shear data
- $Y=0$ case overshoots
- $Y=0.1$ GPa decays to ~ 0
- pressure-dependent strength maintains finite Δt to $X > 4$ mm
- 2 – 4 mm is optimal for distinguishing models
- mesh refinement, artificial viscosity, and compaction law have minimal effect on results when $Y=0.1$ GPa



CTH Mesoscale Simulations

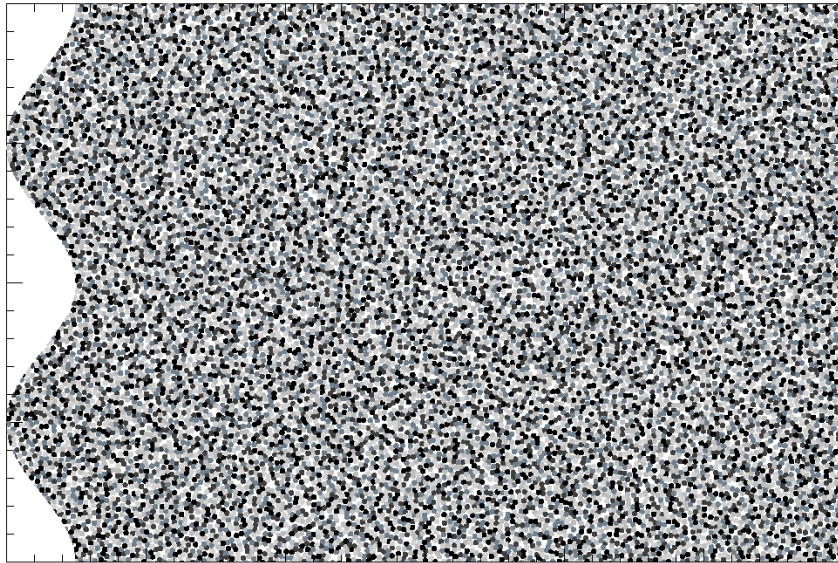

- 2-D mesoscale calculations similar to Borg & Vogler
- individual WC particles idealized as circles
- WC modeled with Mie-Gruneisen EOS and elastic-perfectly plastic strength

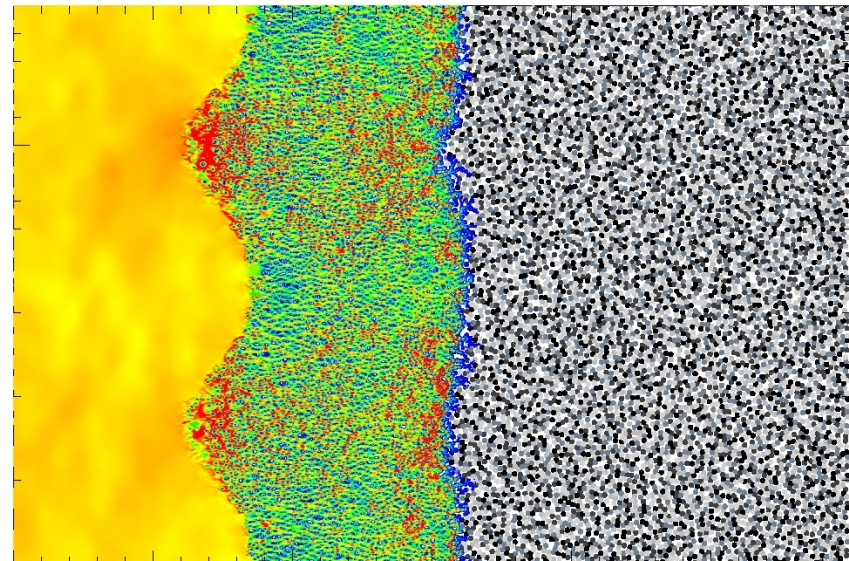
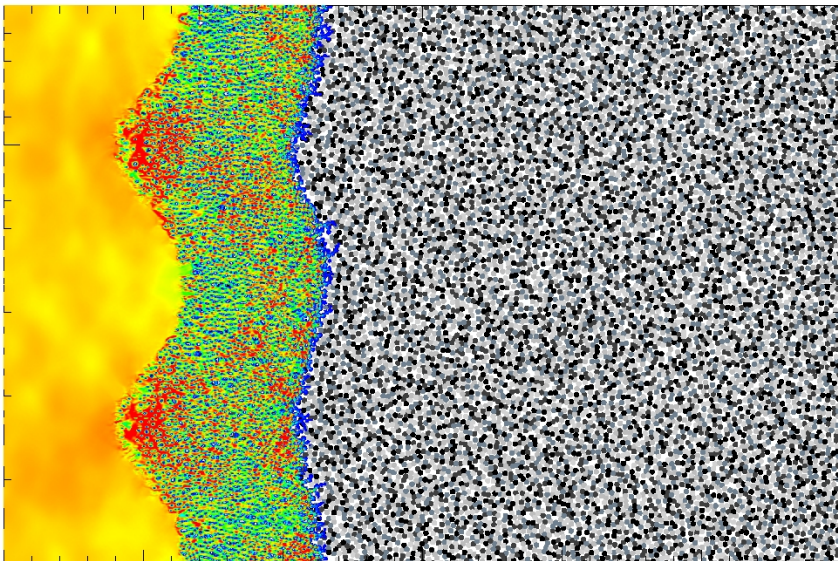



CTH Mesoscale Simulations

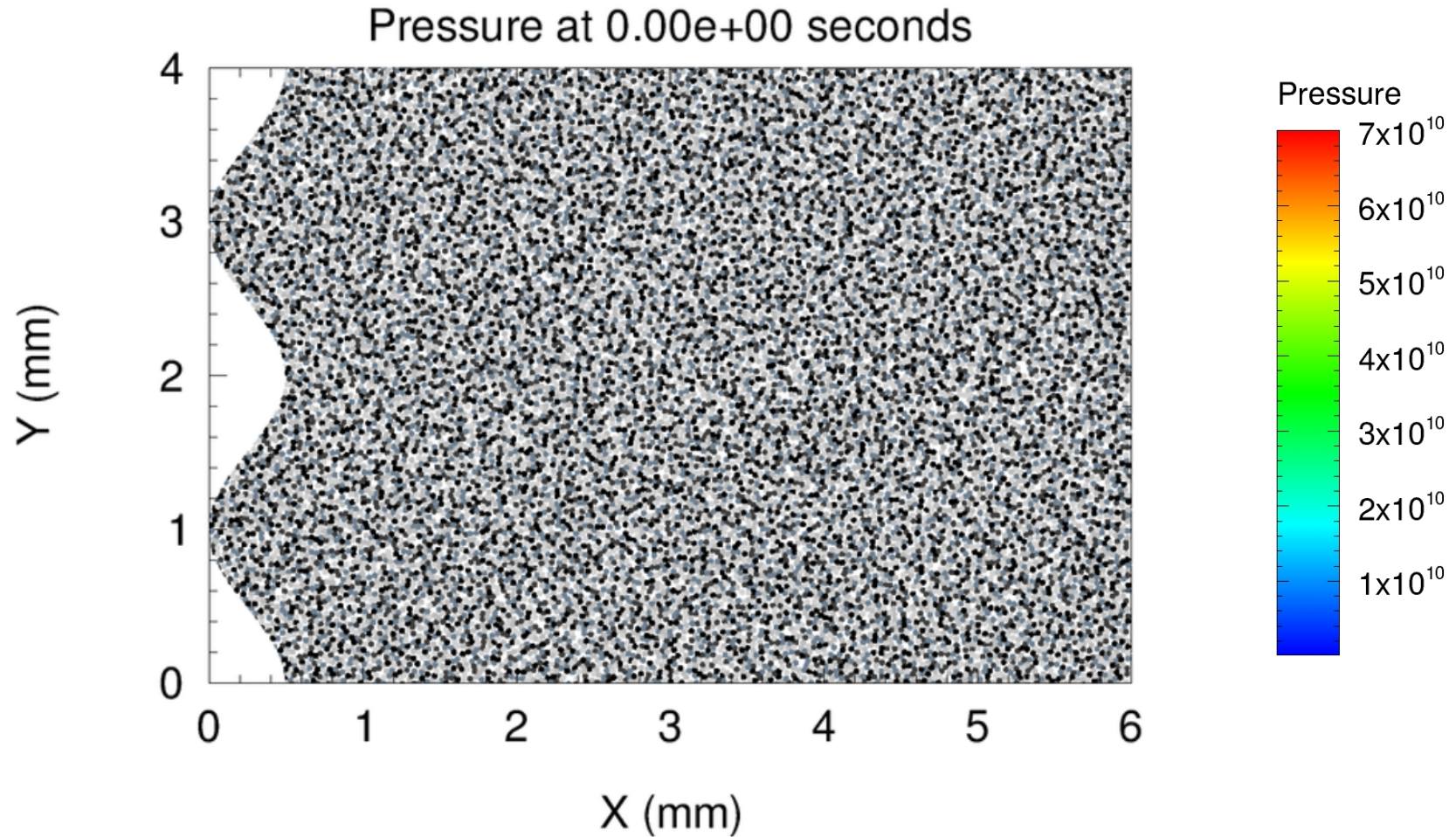



CTH Mesoscale Simulations: Data Extraction

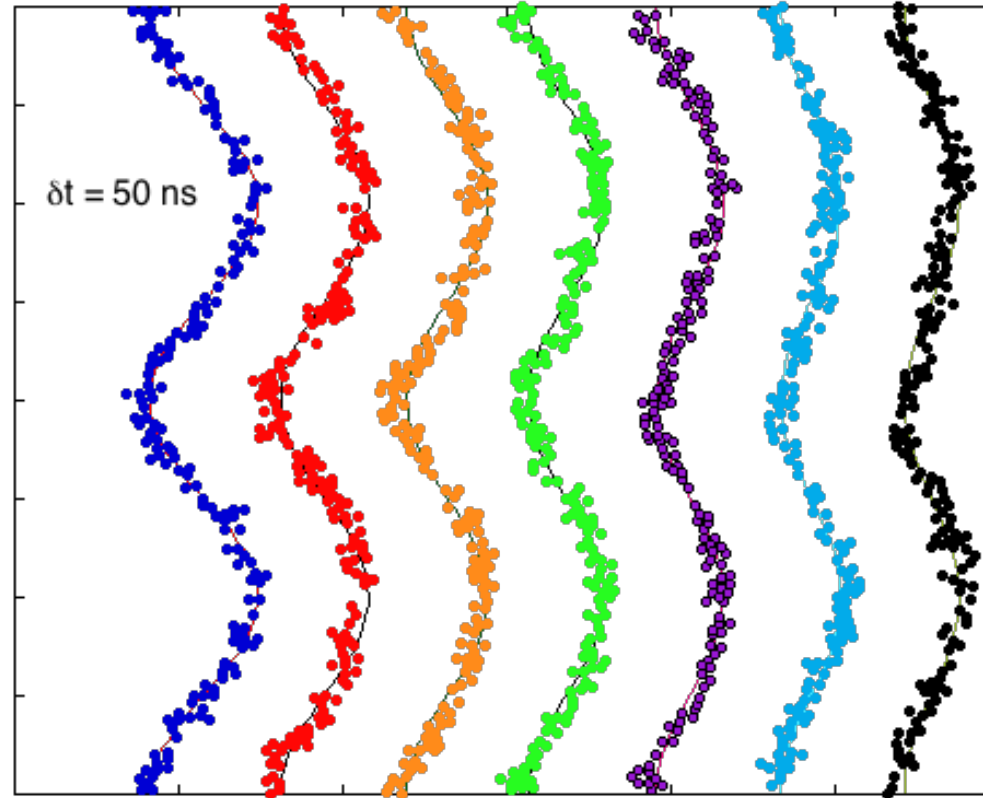

- monitor when each particle reaches half of steady state velocity
- consider particles that reach this level for a given δt
- fit sine wave through resulting point to determine Δt of wave
- somewhat different results obtained when velocities monitored in a homogeneous “window” – reasons unclear



Decay in CTH Mesoscale Simulations

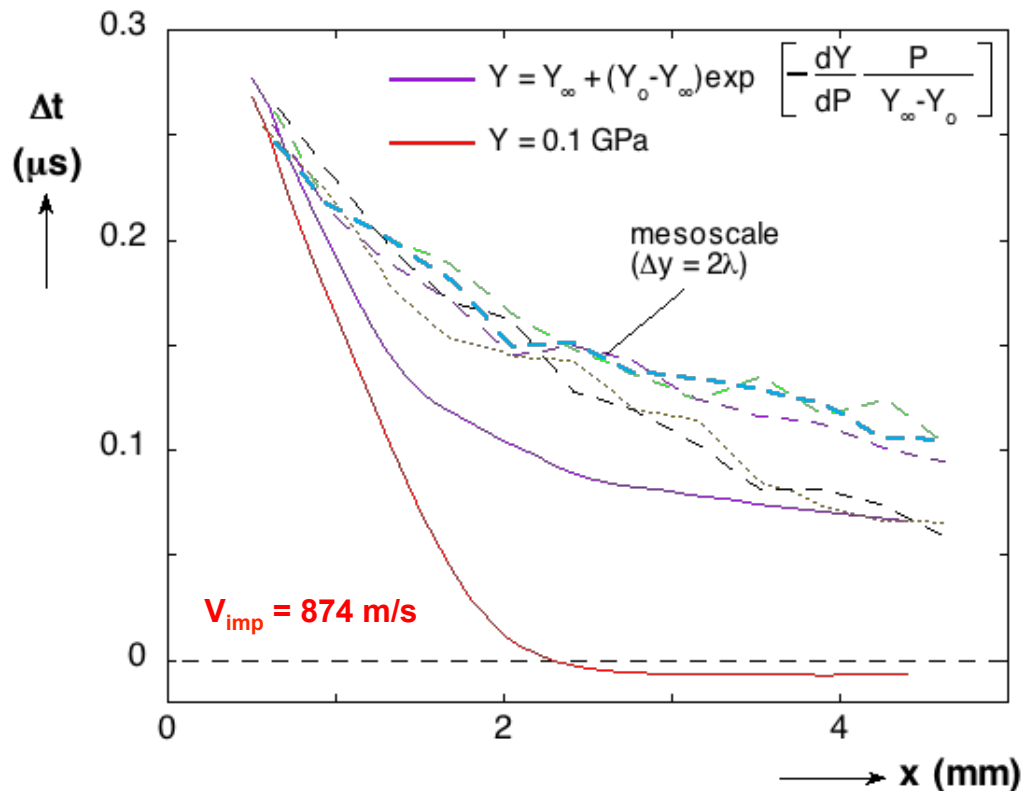

- mesoscale calculations give results that are closer to pressure-dependent model
- significant variability for model size of 2λ
- need to explore sensitivity to other parameters in mesoscale calculations (e.g., interface treatment, fracture)
 - interface treatment / friction
 - fracture
 - etc.



Experimental Configuration

$\lambda=2\text{mm}$, $2a = 0.5\text{ mm}$

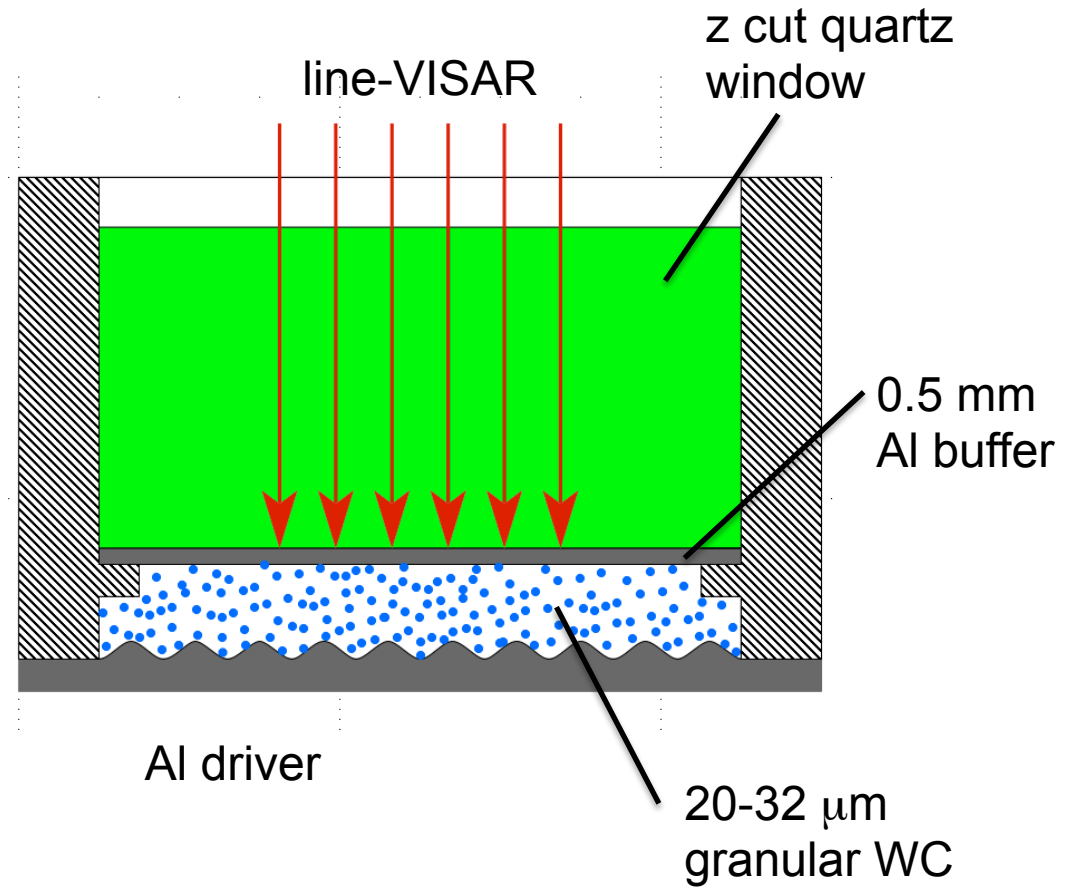
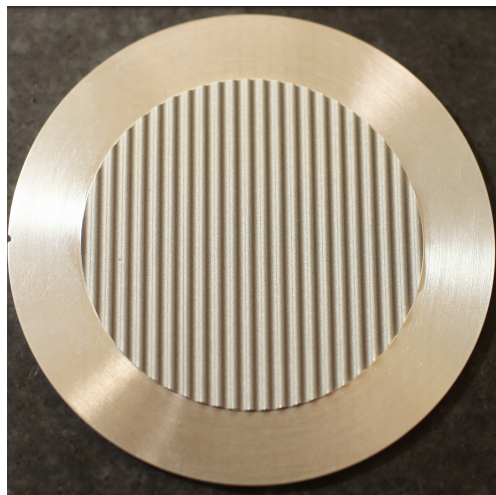
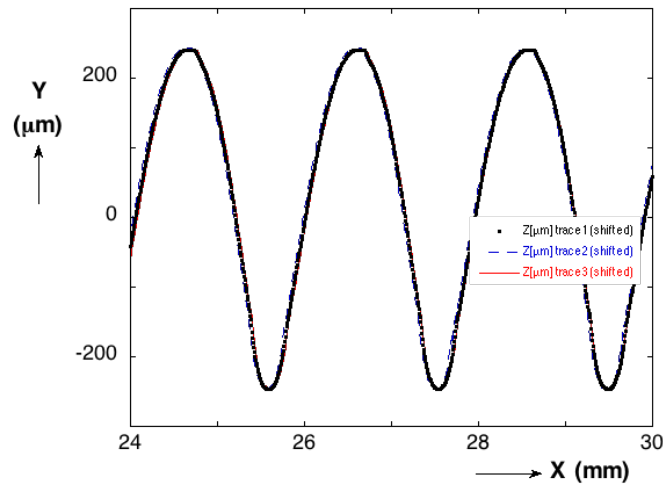



Perturbation Decay Measurement with Line-VISAR

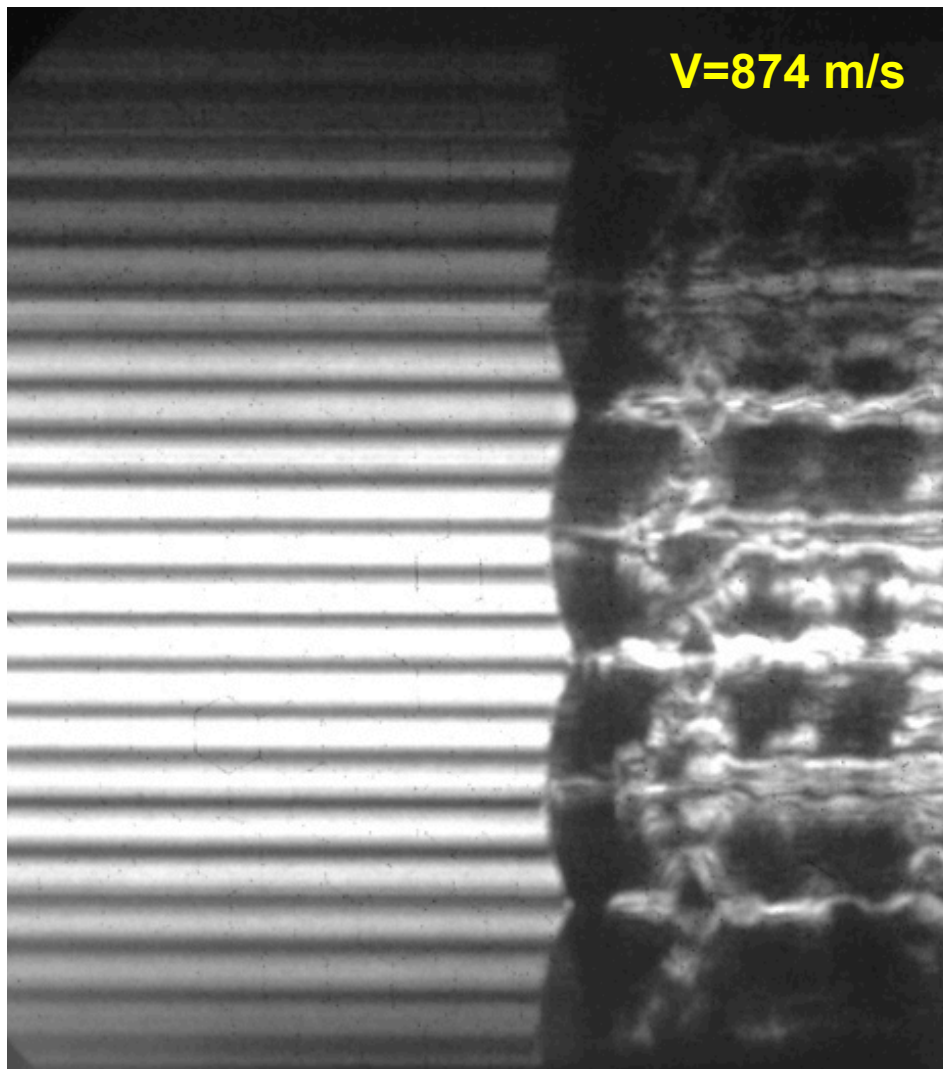

- sample was 2.53 mm from top of perturbation to buffer
- perturbation of flow obvious; post-shock arrival difficult to interpret
- analysis approach simplistic
- will require large number of shots to populate perturbation decay plot





Experimental Results

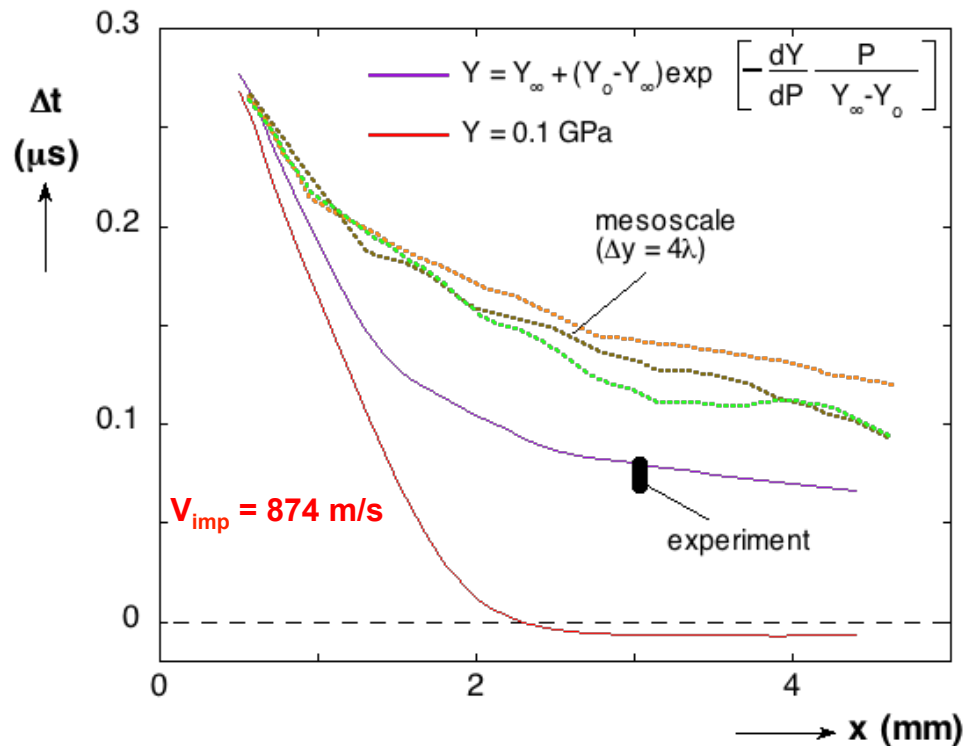

- experimental results similar to pressure-dependent model and below mesoscale
- more data needed to better resolve behavior



Conclusions

- perturbation decay experiments appear capable of discriminating different strength behaviors for granular materials - increased strength delays perturbation decay
- initial experiments with line-VISAR are promising
- results at 874 m/s consistent with pressure-dependent continuum model and below mesoscale model; at 327 m/s results fall below p-d and meso models
- mesoscale results surprisingly dependent on realization
- alternate formulations for mesoscale model may provide additional insight
- other experimental approaches in development