

Pure-Rotational fs/ps CARS Measurements of Temperature and Concentration using a Second-Harmonic Bandwidth- Compressed Probe

Sean P. Kearney

Engineering Sciences Center

Sandia National Laboratories

Albuquerque, NM 87185

(spkearn@sandia.gov)



*Exceptional
service
in the
national
interest*



Sandia National Laboratories is a multi-program laboratory managed and operated by Sandia Corporation, a wholly owned subsidiary of Lockheed Martin Corporation, for the U.S. Department of Energy's National Nuclear Security Administration under contract DE-AC04-94AL85000.

Motivation: Verify the accuracy and precision of fs/ps rotational CARS for

- A wide range of stoichiometry
- Hydrogen and hydrocarbon fuels
- Sooting conditions

▪ fs CARS processes

- Femtosecond preparation of Raman coherence at $t = 0$
- Picosecond probing and synthesis of CARS spectra

▪ Hybrid fs/ps Pure-Rotational CARS Experiments

- Requirements for probe-beam generation
- SHBC process for high-energy probe beam
- Temperature and O_2/N_2 measurements in near-adiabatic H_2 /air flames: accuracy and precision
- Thermometry in C_2H_4 /air flames: accuracy and precision

▪ Summary and Conclusions

fs/ps CARS Experimental Arrangement

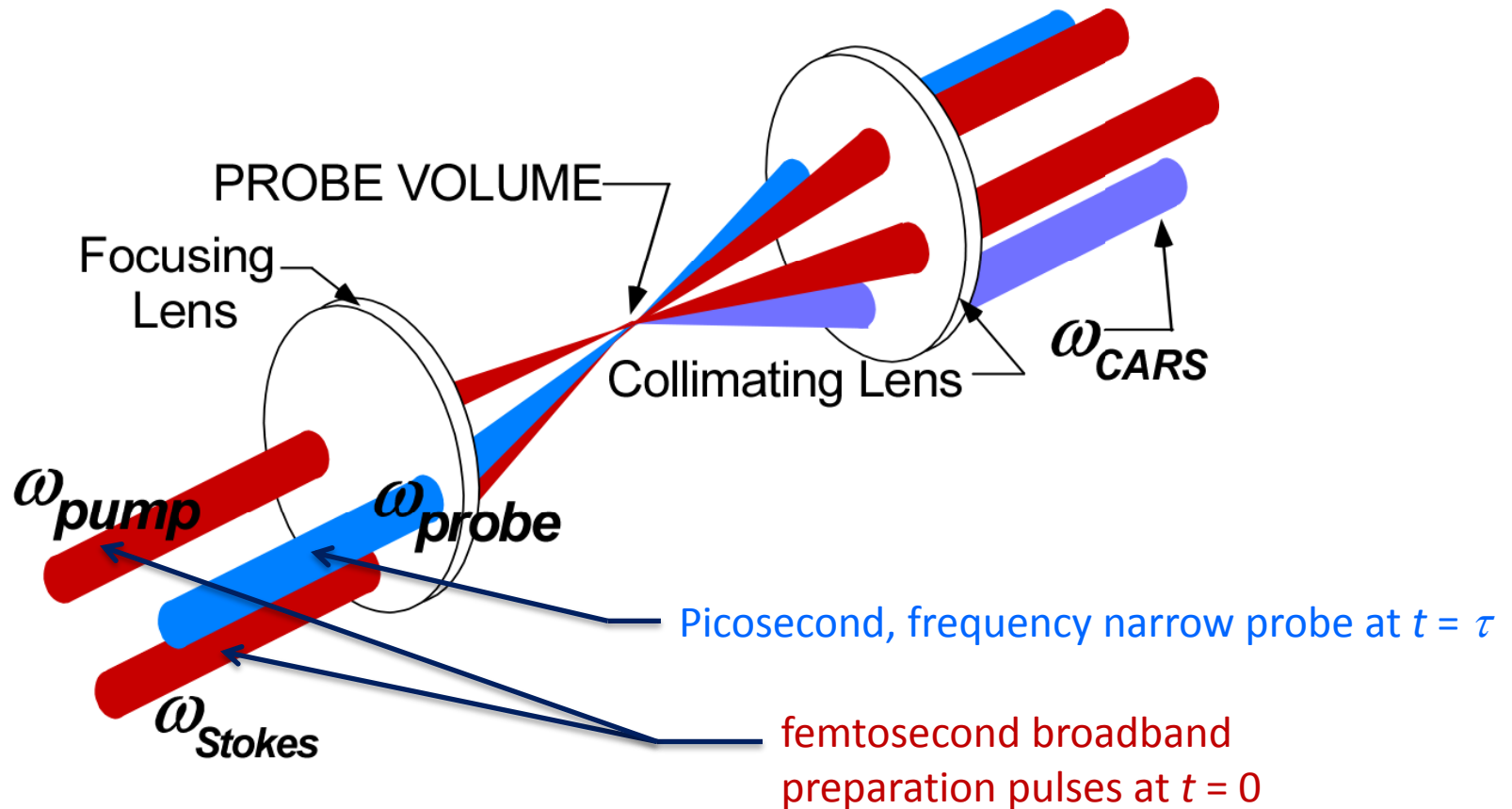

Time-Domain Rotational Raman

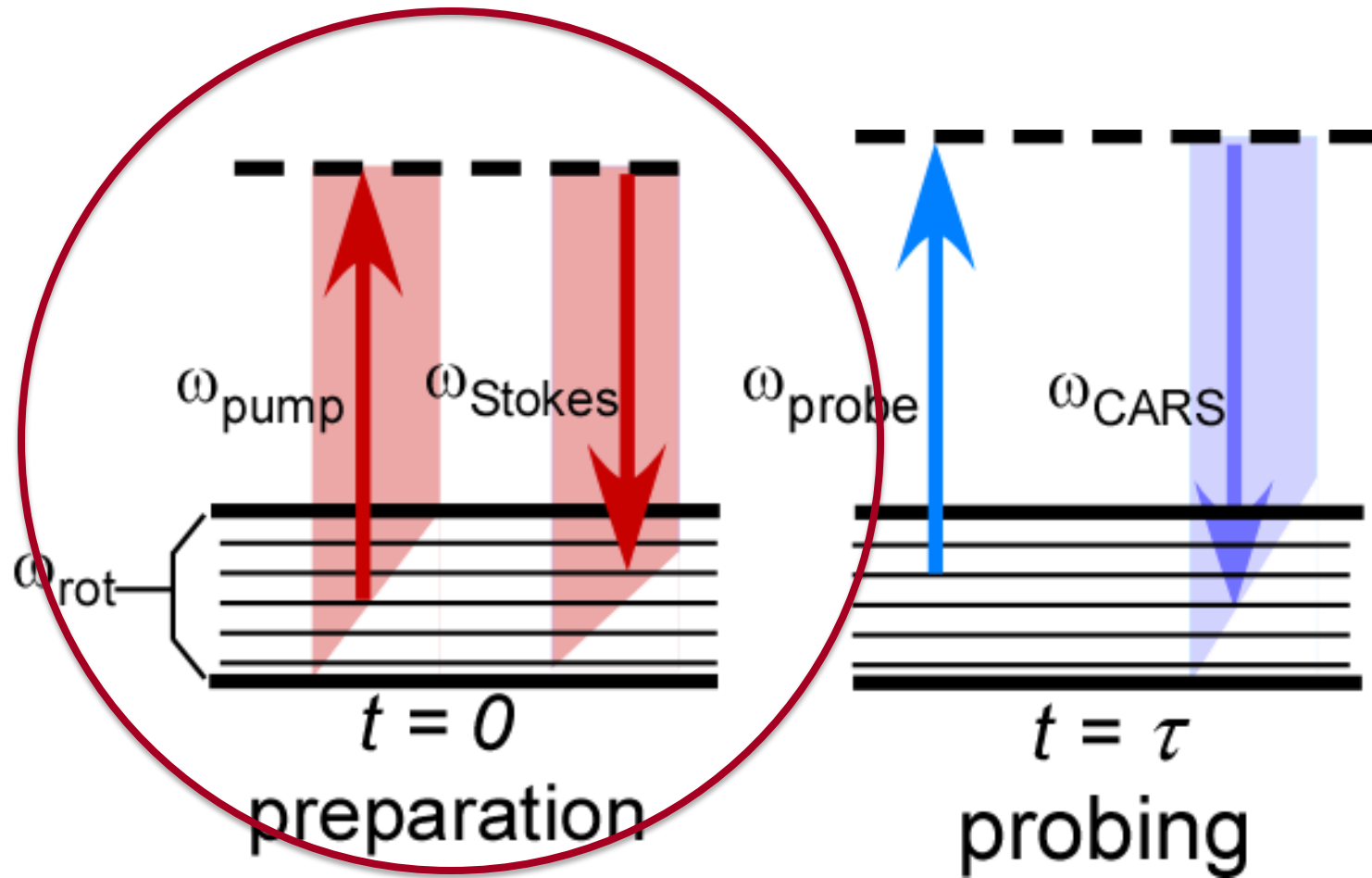

Pump/Stokes Preparation

- Impulsive molecular alignment at time $t = 0$
- Assembly of rotors at the beat frequency between upper and lower J states
- Rotor energy levels are evenly separated: $\omega_J = 4B(J + 3/2)$
- Rotors periodically “rephase”

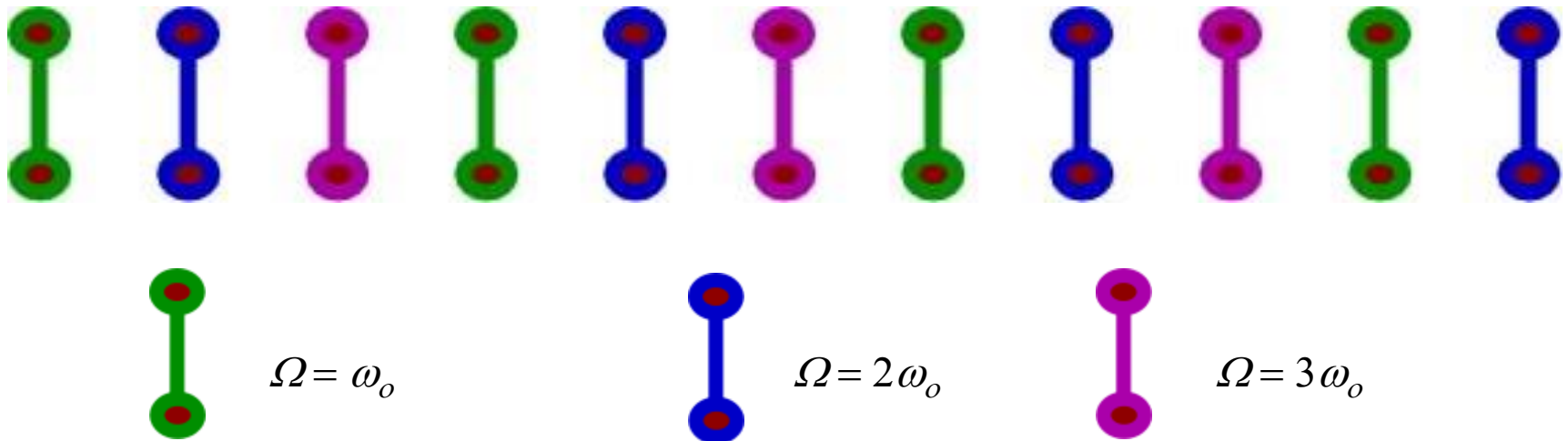

- The result is a periodically recurring and long-lived Raman polarization
- Assembly rotates according to its thermal (Boltzmann) distribution

Measured Response in N₂ at T = 300 K

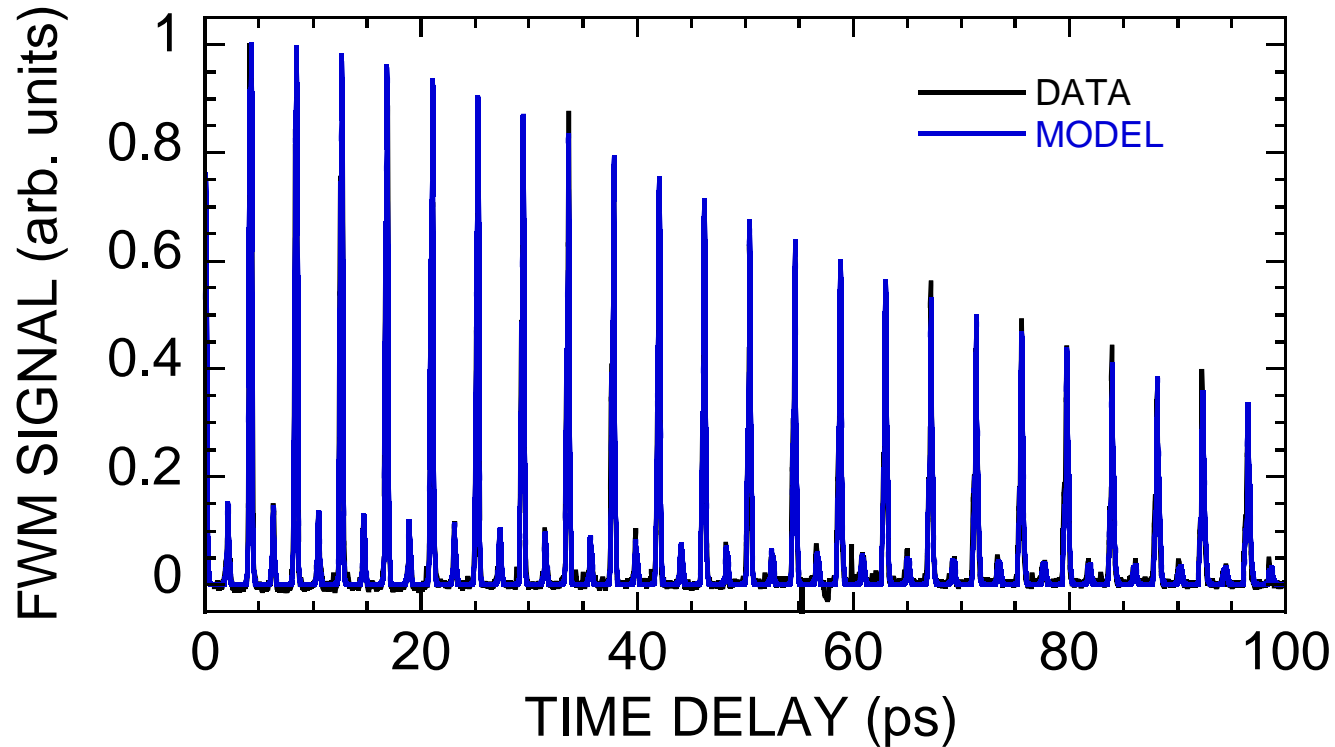

$$\chi = \sum_J W_J \exp(i \omega_J t) \exp(-\Gamma_J t)$$

Probe Step

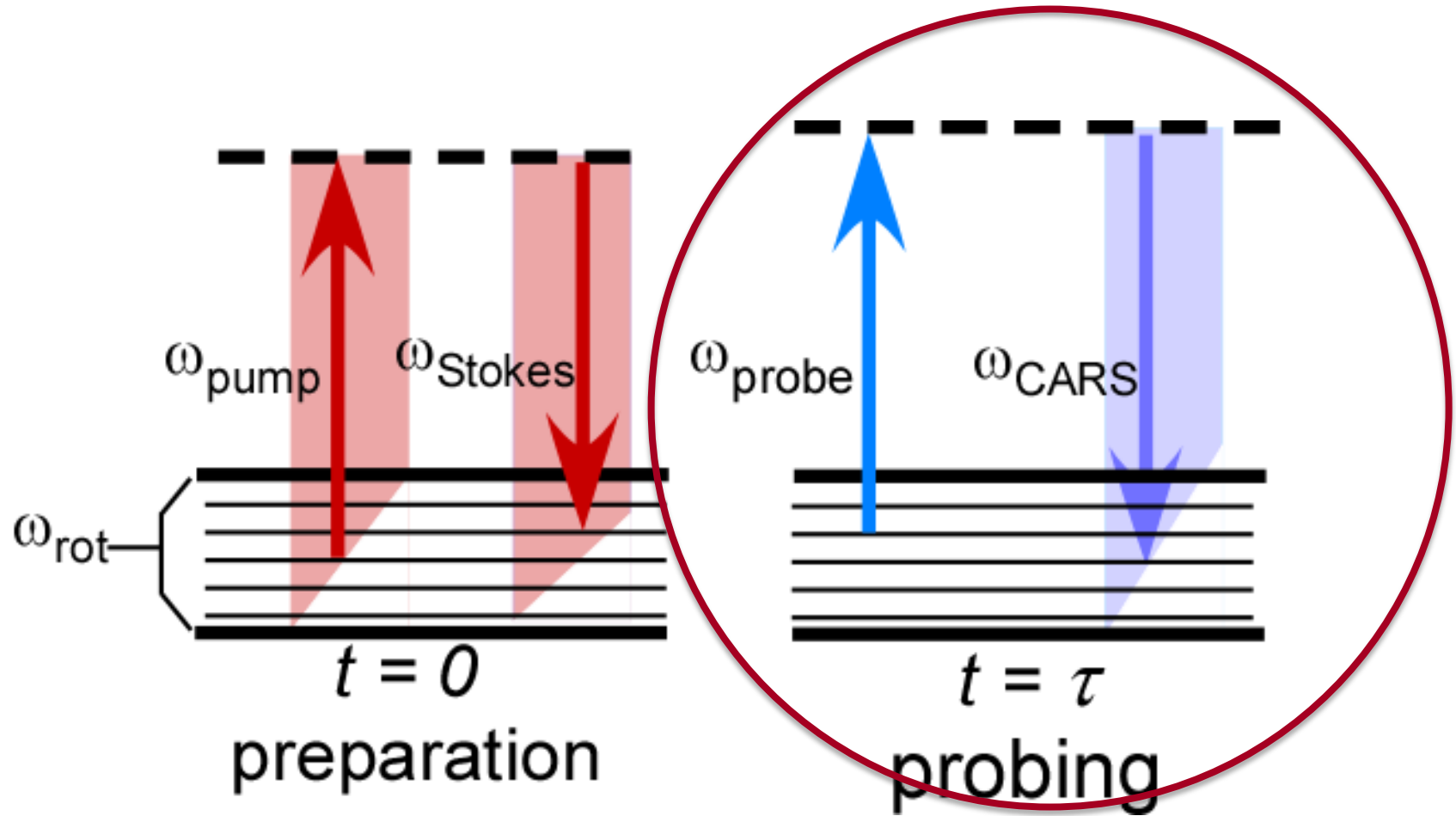

Probe Step and Spectral Synthesis

Pure Gases, T = 300 K

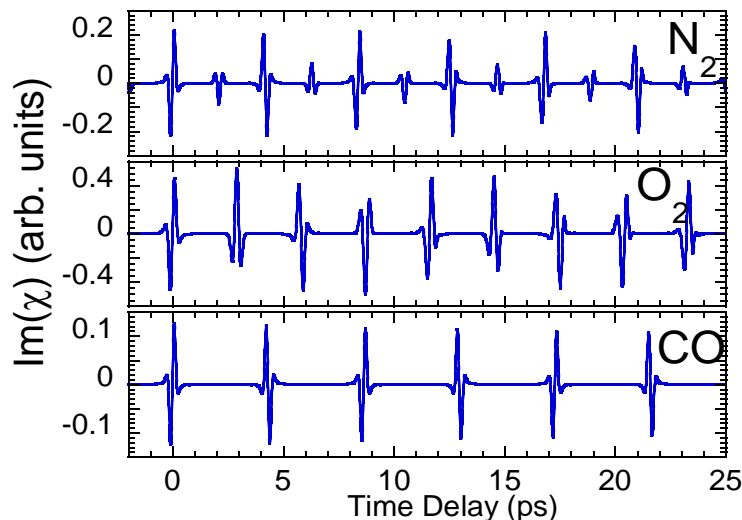

$$\chi = \sum_J W_J \exp(i \omega_J t) \exp(-\Gamma_J t)$$

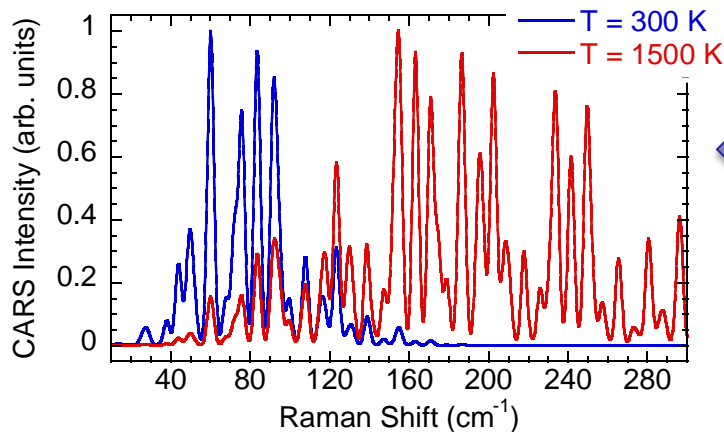

Air

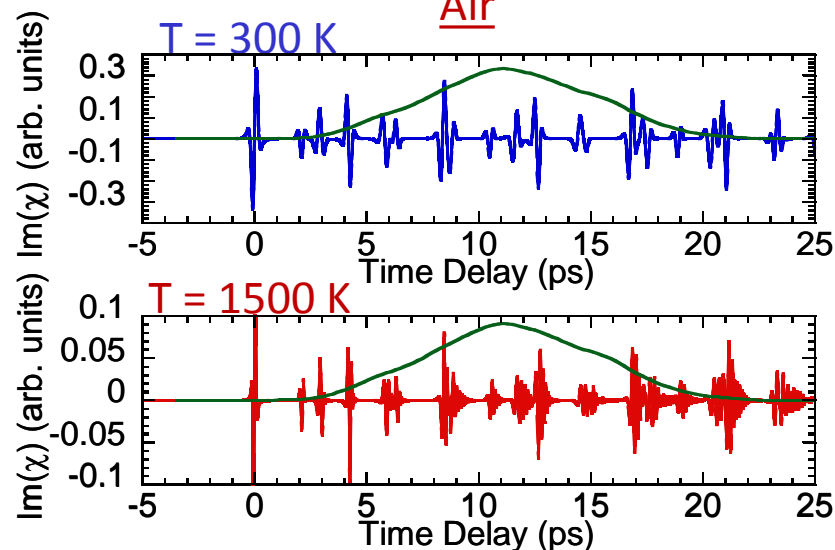

$$\chi = \sum_k X_k \sum_J W_J^{(k)} \exp(i \omega_J^{(k)} t) \exp(-\Gamma_J^{(k)} t)$$



$$E_{CARS}(t) = E_{pr}(t - \tau) \exp[i \omega_o(t - \tau)] \times \chi(t)$$

Requirements

- Frequency narrow to resolve Raman lines
- Fourier transform limit
 $\Delta t \Delta \omega \leq \text{const.}$
- Picosecond-duration probe is needed
- Must be phase-locked to preparation pulses

Previous work: direct “bandwidth carving”

- 4f pulse shapers (Miller et al.)
- Fabry-Perot etalons (Stauffer et al., Kearney et al.)
- Low pulse energy!
- Insufficient CARS signal at flame temps!

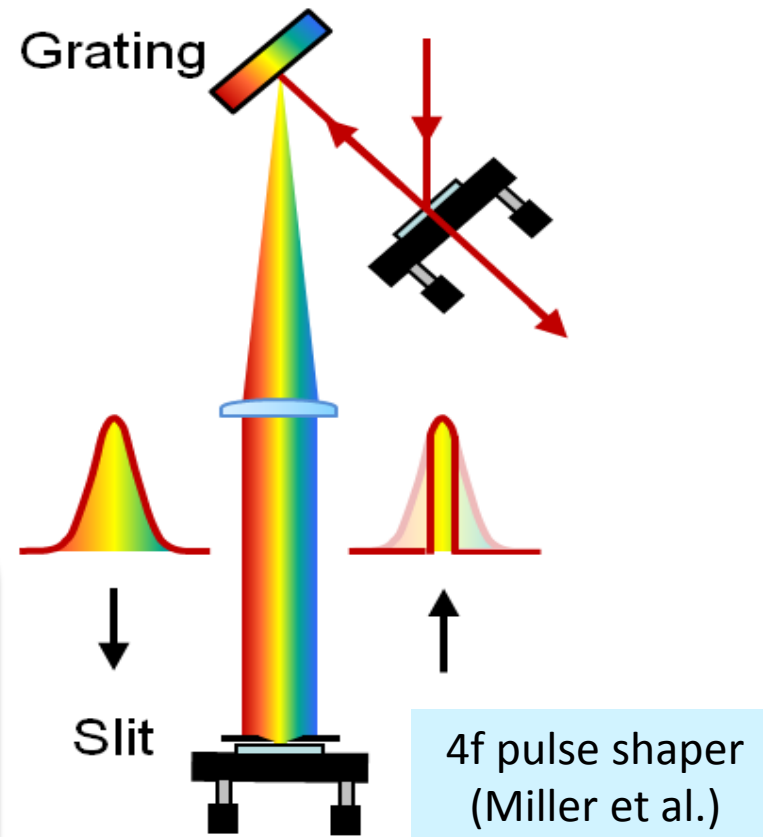

Second-Harmonic Bandwidth Compression (SHBC)

- Commercial device (Light Conversion)
- Converts fs radiation at 800 nm to ps radiation at 400 nm
- Grating pulse stretchers
- **Phase-conjugate** temporal chirps imparted upon broadband fs pumps
- Sum-frequency generation in BBO
- Output linewidth 3.5-4.0 cm^{-1}

$$\Delta\omega_{sfg} \sim d\omega/dt$$

$$\Delta\omega_{sfg} \sim (\Delta t)^{-1}$$

- Conversion efficiency: 35-50%!
- Output pulse energy: 1-1.4 mJ!

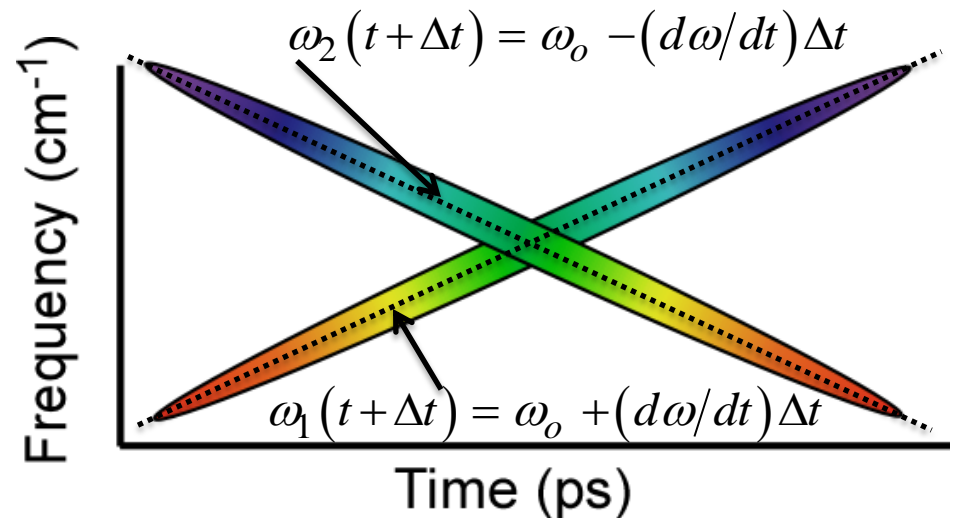
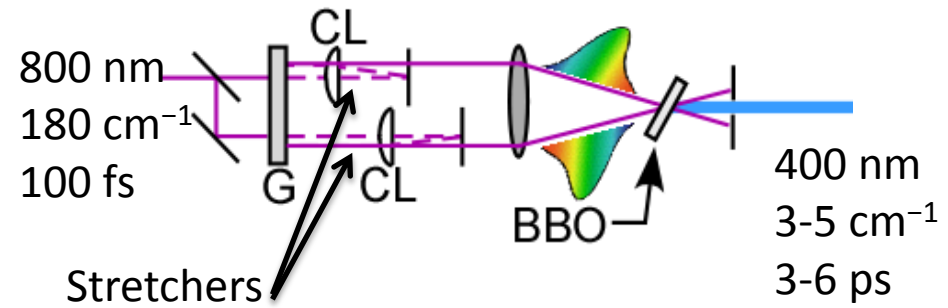

$$\omega_{sfg} = \omega_1 + \omega_2 = 2\omega_0$$

fs/ps CARS Instrument

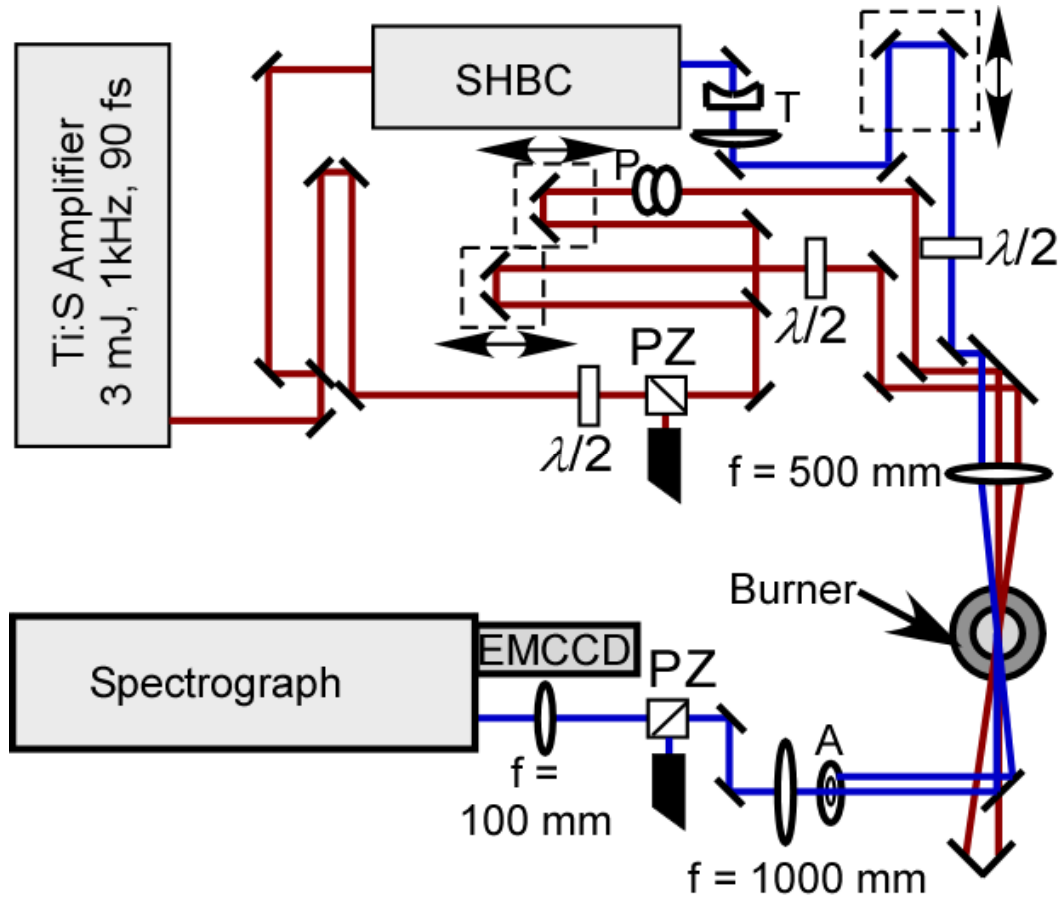

Hencken Burner

- Slightly lifted flat flame
- Flow rates 98 to 116 SLPM
- Non-premixed
- Provides *nearly adiabatic flames*
- Temperature and major species mole fractions *calculated from equilibrium*

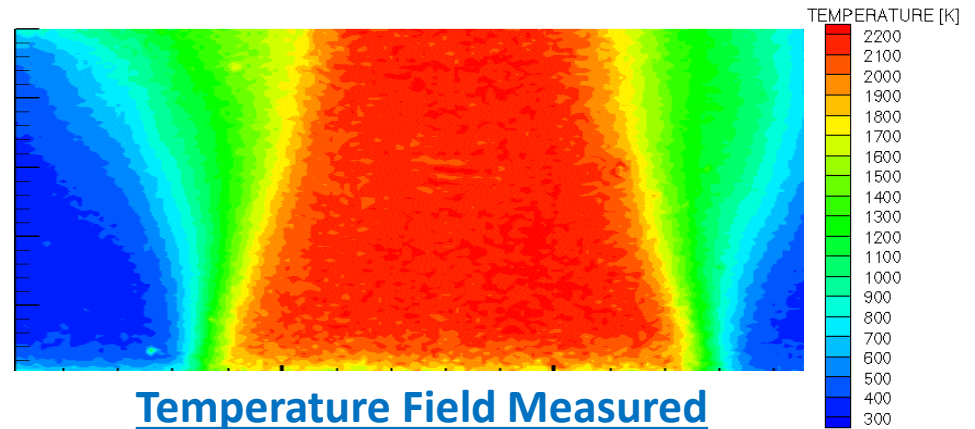

Temperature Field Measured
by Rayleigh Scattering
(CH₄/air)

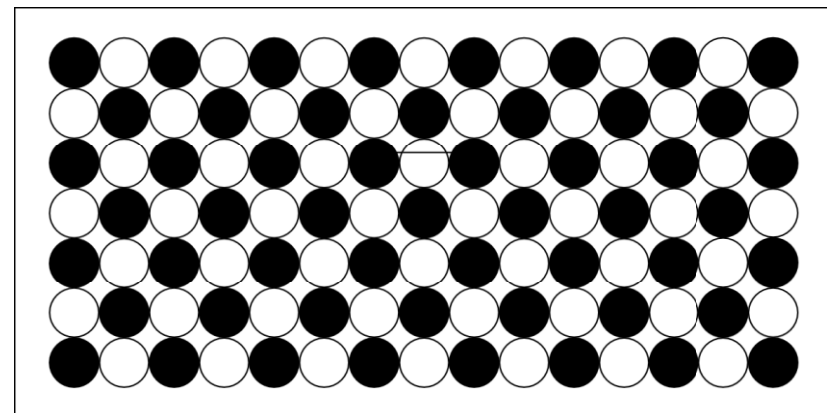

Burner Hole Configuration

Shot-Averaged Spectra from Near-Adiabatic H₂/air flame

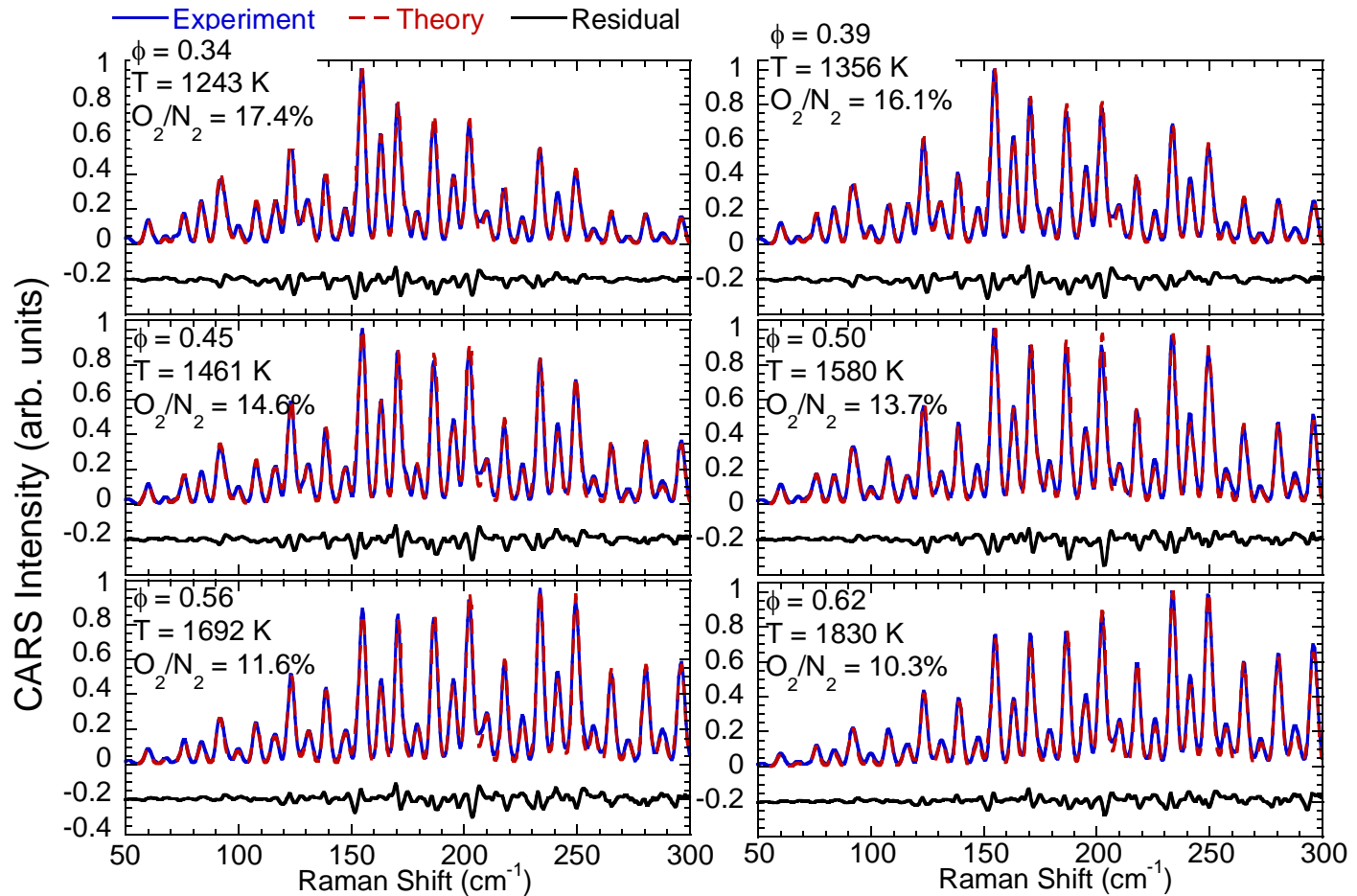

- Spectra averaged for several thousand laser shots to optimize SNR
- N₂ contributions dominate all spectra
- O₂ sensitivity arises from alteration of spectral “envelope” and subtle line shifts

Sensitivity to O₂ Content

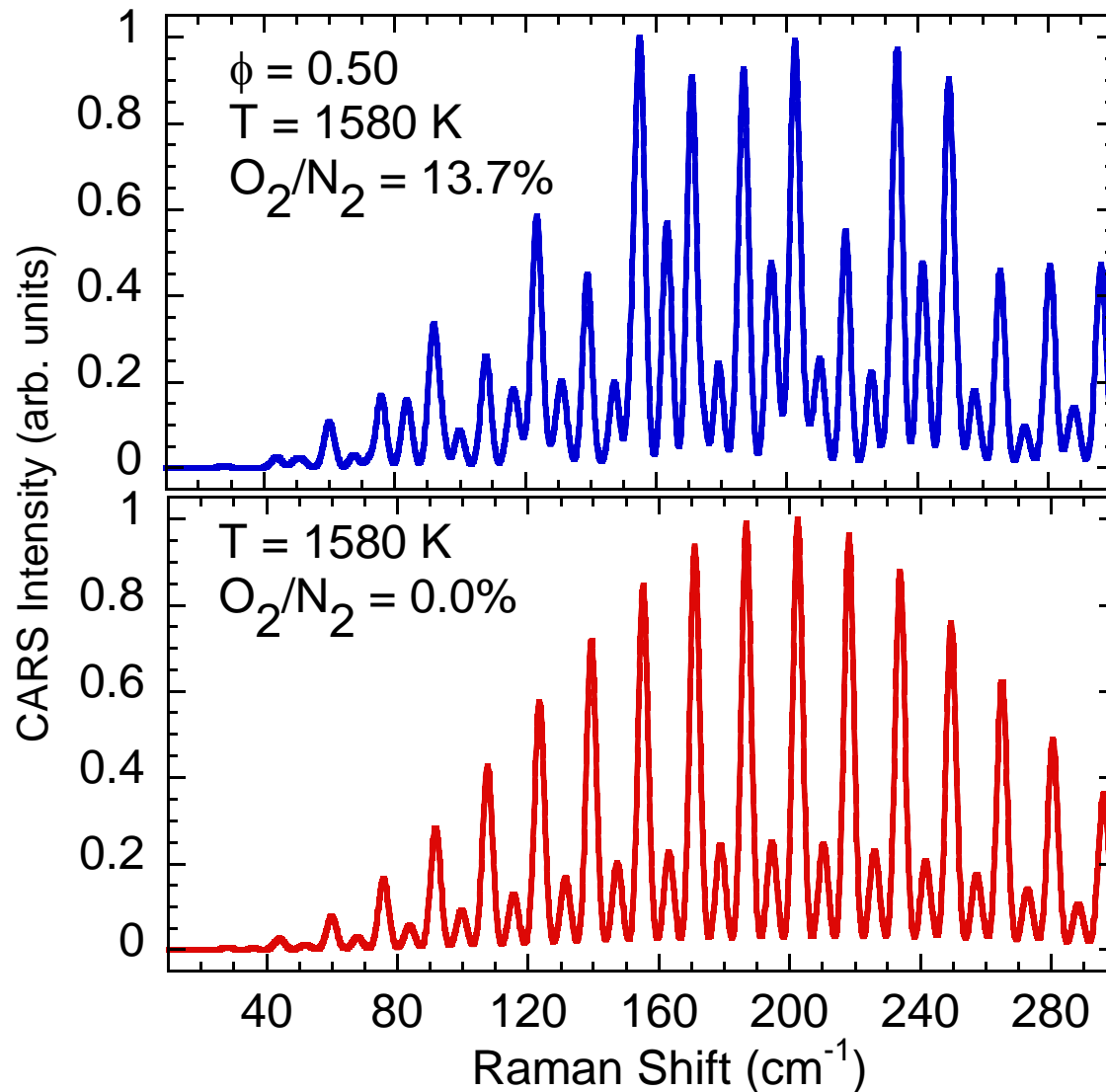

Single-Shot Spectra from Near-Adiabatic H₂/air flame

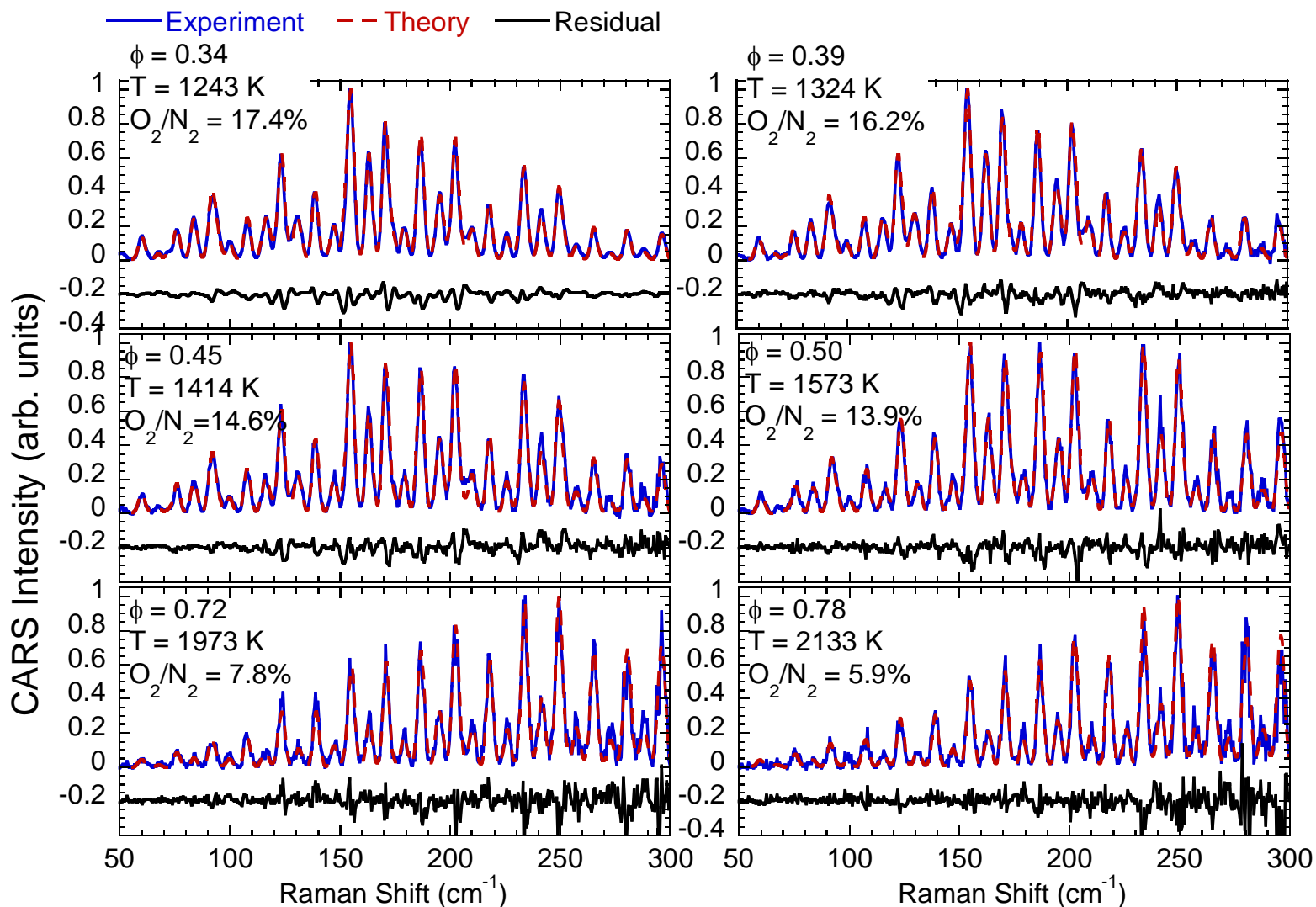

Temperature and O₂/N₂ Measurement Precision

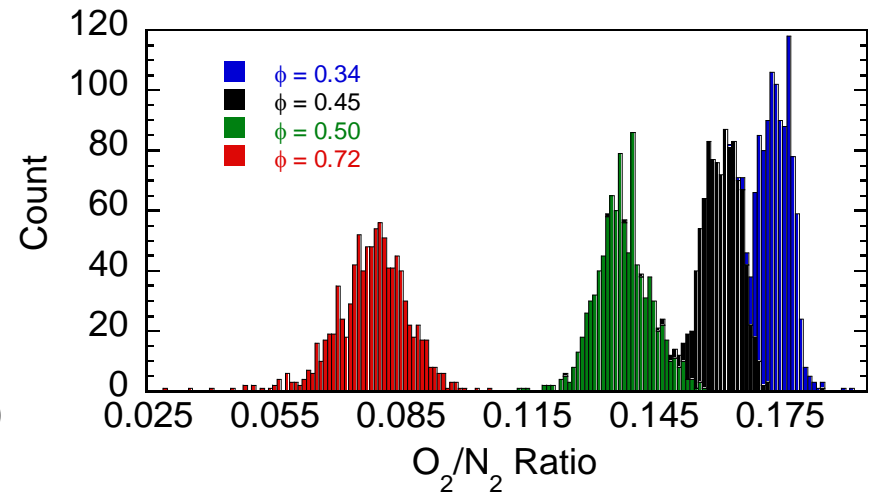
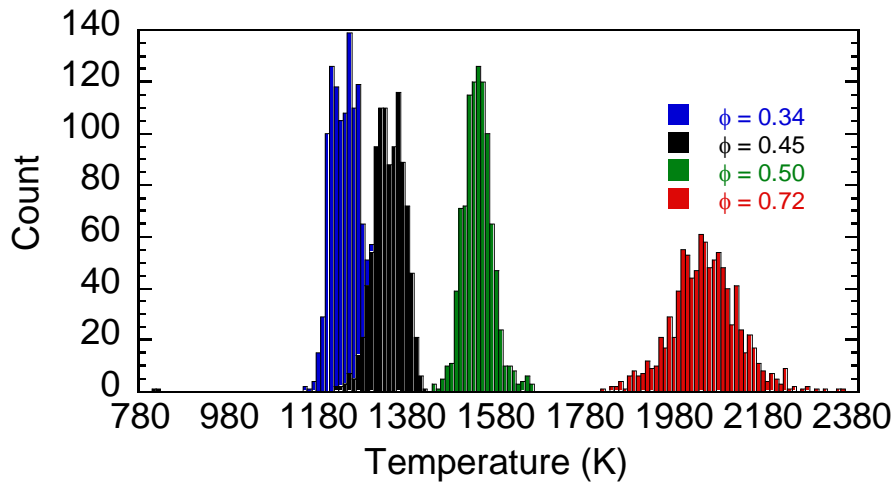

ϕ	T(K)	σ_T (K/%)	O ₂ /N ₂	σ_{O_2} (-/%)
0.34	1235	26.8/2.2%	17.4%	0.34/1.95%
0.39	1338	40.7/3.0%	16.1%	0.46/2.85%
0.50	1539	32.8/2.1%	13.7%	0.64/4.67%
0.72	2051	75.2/3.6%	7.8%	0.85/10.9%

EM Gain ON

- Temperature precision is 2-3% with EM gain off
- Best results with fs CARS are ~1%.
- ns rotational CARS ~ 3-4%

Acoustic Interaction at ϕ up to 0.55

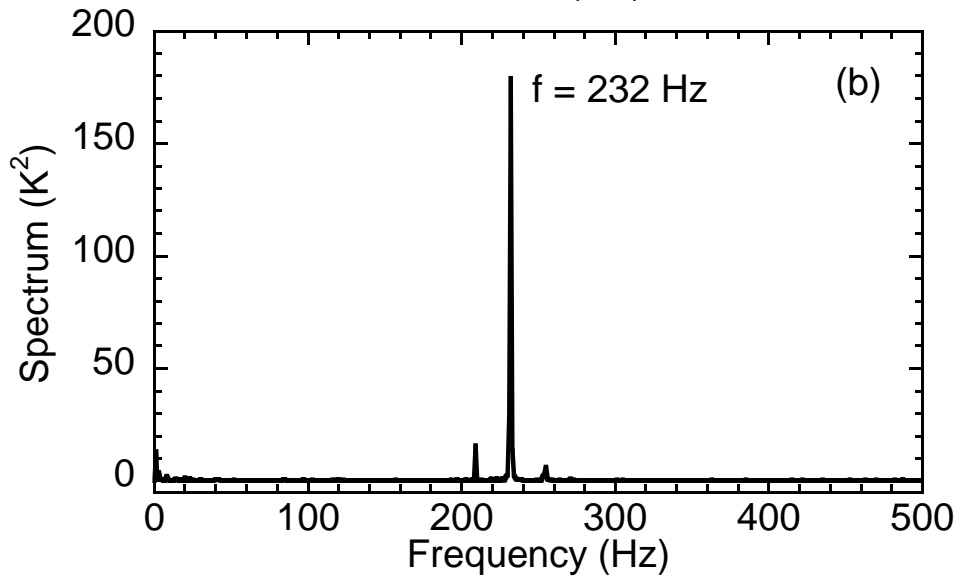
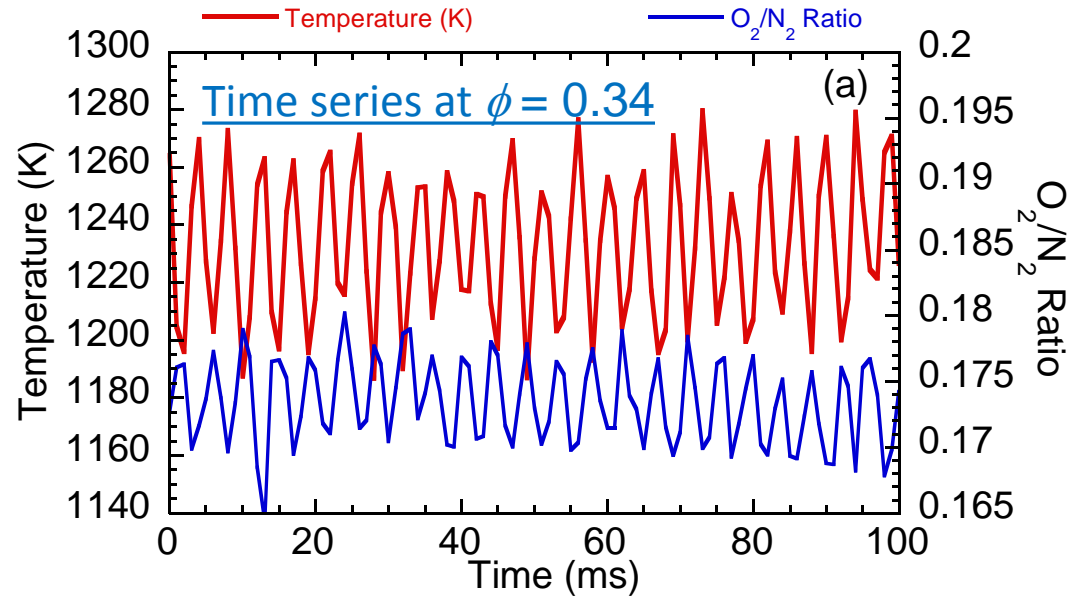

- Audible “hum” from burner at leanest stoichiometries
- Inspection of T and O_2 data reveals oscillation in both signals
- Sampled at 1 kHz
- Negative correlation is consistent with low-level oscillations in ϕ
- Amplitude of temperature oscillation is ~ 30 K (2.4%)
- Distinct peak in PSD near 232 Hz is consistent with tone heard from the burner
- Precision could be understated

H₂/Air Flame Measurement Accuracy

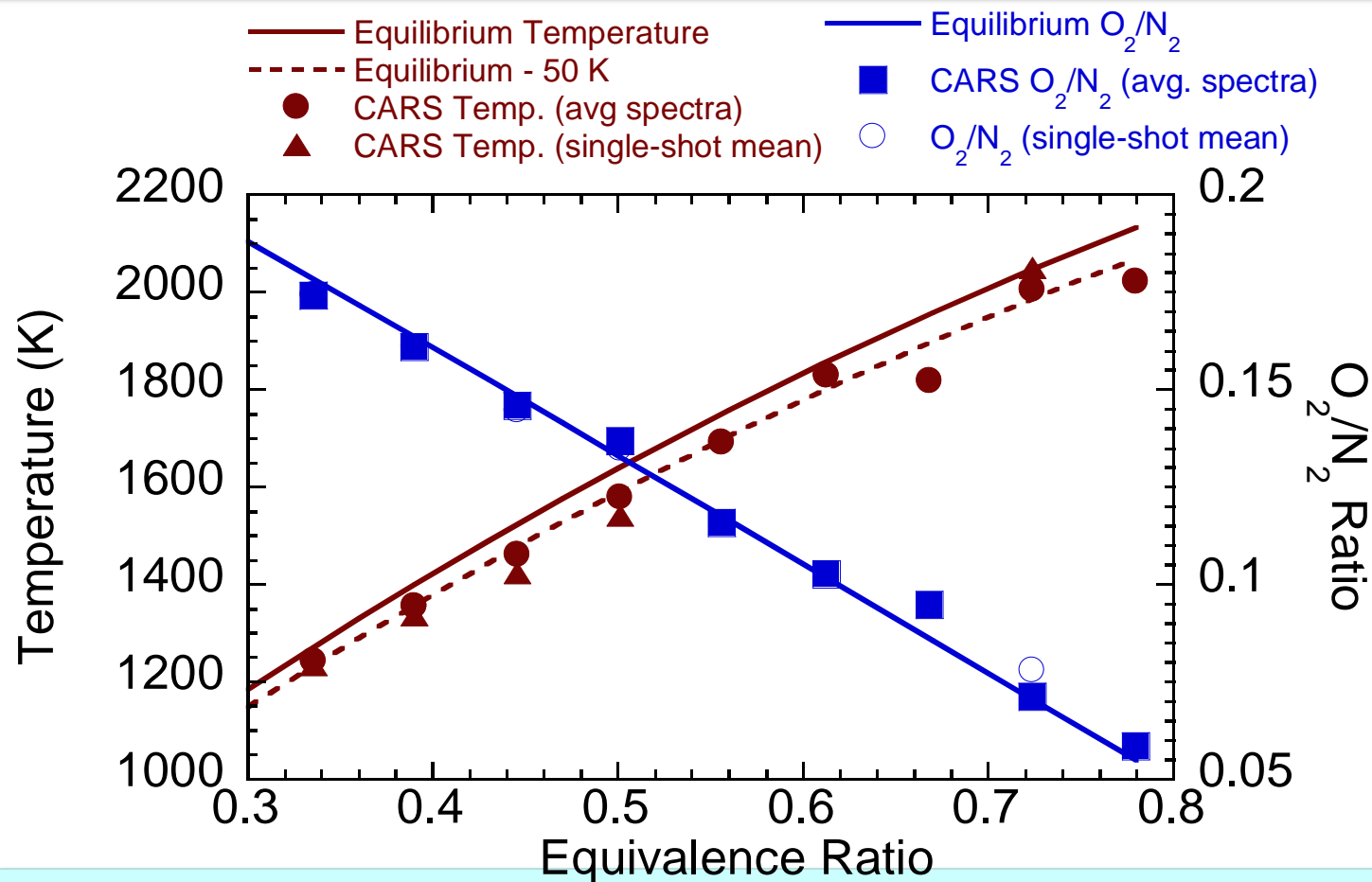

- Temperature accuracy: -3% when shot-averaged spectra are used
- Temperature accuracy: -3-6% when single-shot means are used
- O₂/N₂ accuracy is ±6%
- Uncertainty due to metered gas flows: Temperature ±3% / O₂/N₂ ±6-12%

C₂H₄/Air Flames on McKenna Burner

- Premixed hydrocarbon/air flame
- Water-cooled non-adiabatic burner
- Stable region ~5-15 mm above burner
- Previously studied at $\phi = 3.14$ in our lab (and elsewhere!)
- Wide range of stoichiometry, $\phi = 0.75$ to 3.14
- Potential contributions from N₂, O₂, CO, (CO₂ minimized by probe delay)

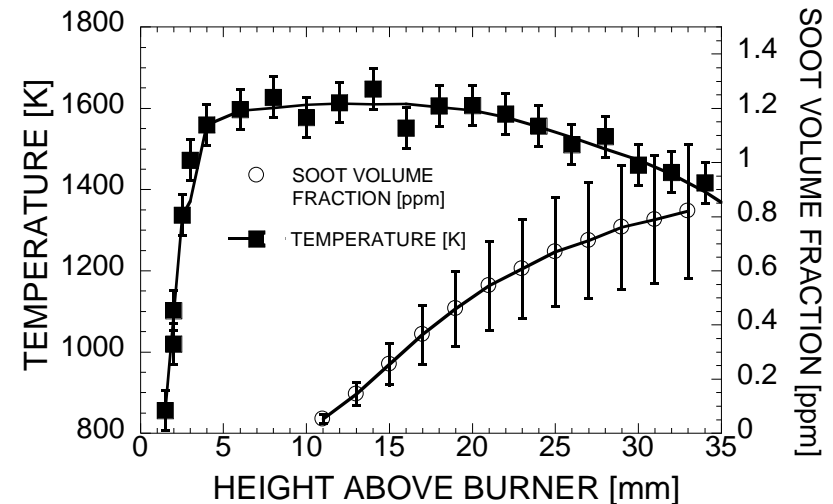
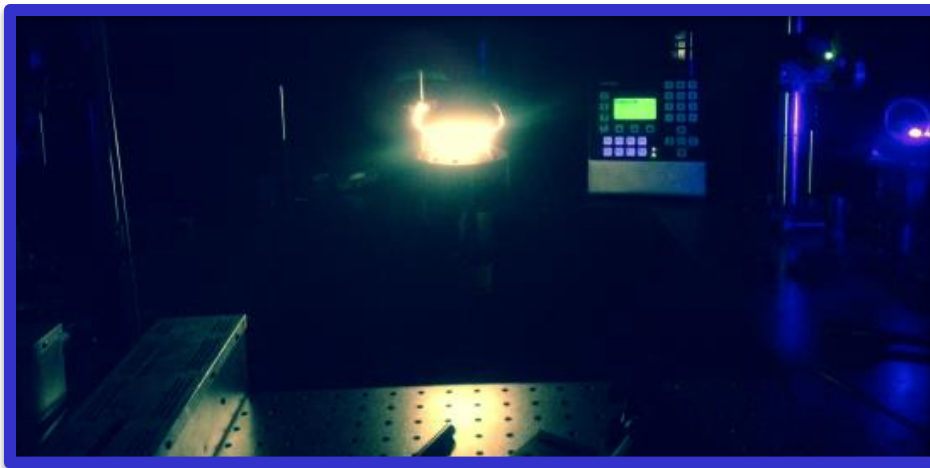
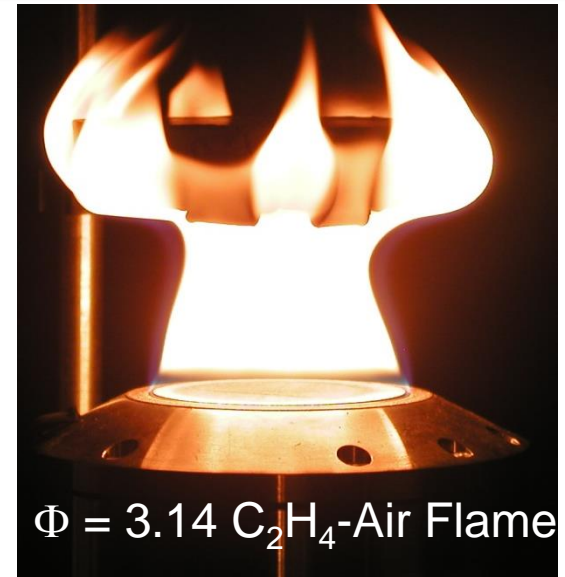

C₂H₄/Air Flame Spectra

Shot-Averaged

Single-Shot at 1 kHz

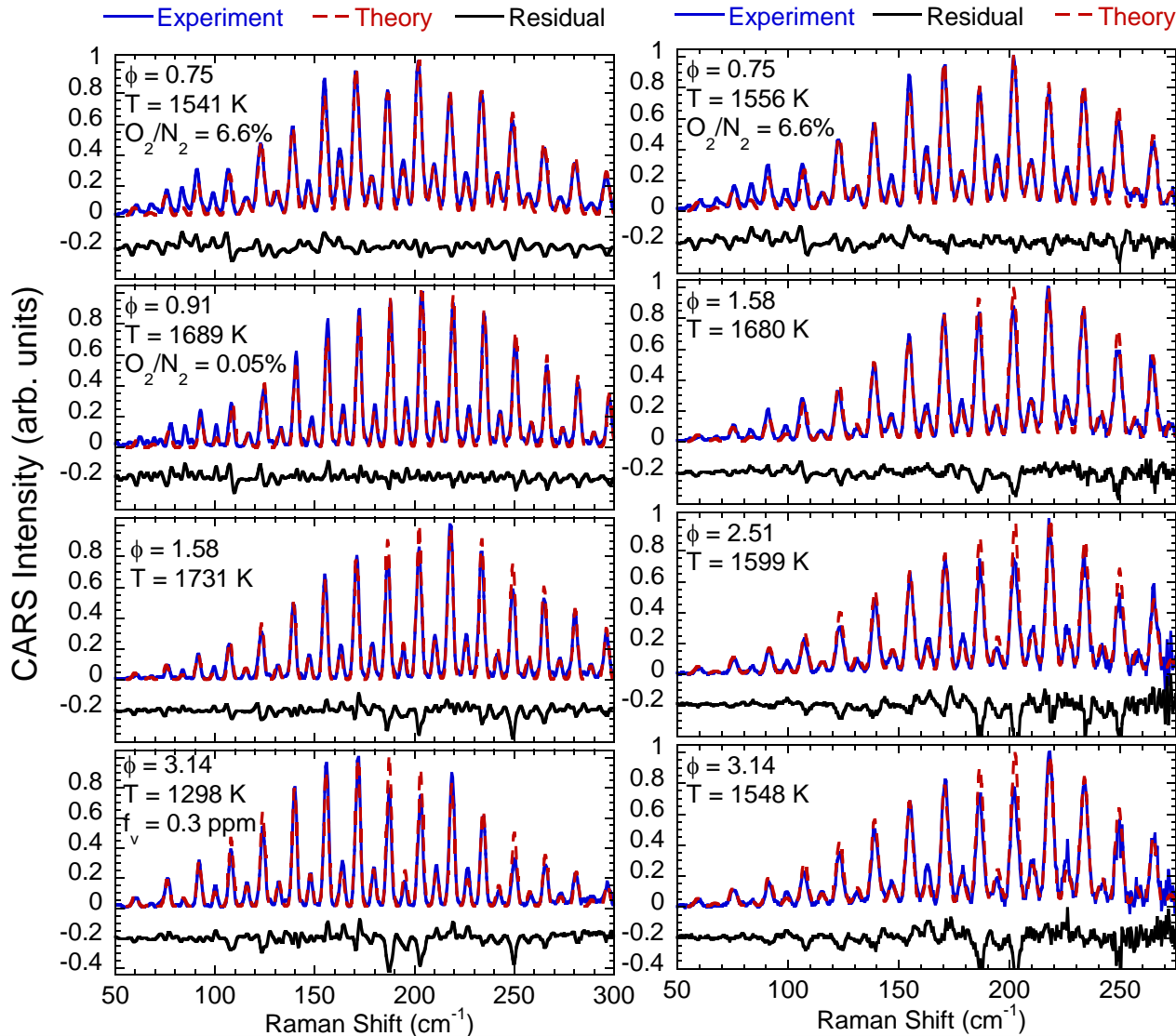

- Spectra acquired for fuel-lean to rich sooting flames
- High-quality fits observed for $\phi < 1$
- Systematic bias toward “underfit” of isolated lines for fuel-rich flames
- Fitted temperature appears to be robust
- Reliable spectra obtained in sooting regions of the flame
- No EM gain used

Temperature Histograms C_2H_2/Air Flame

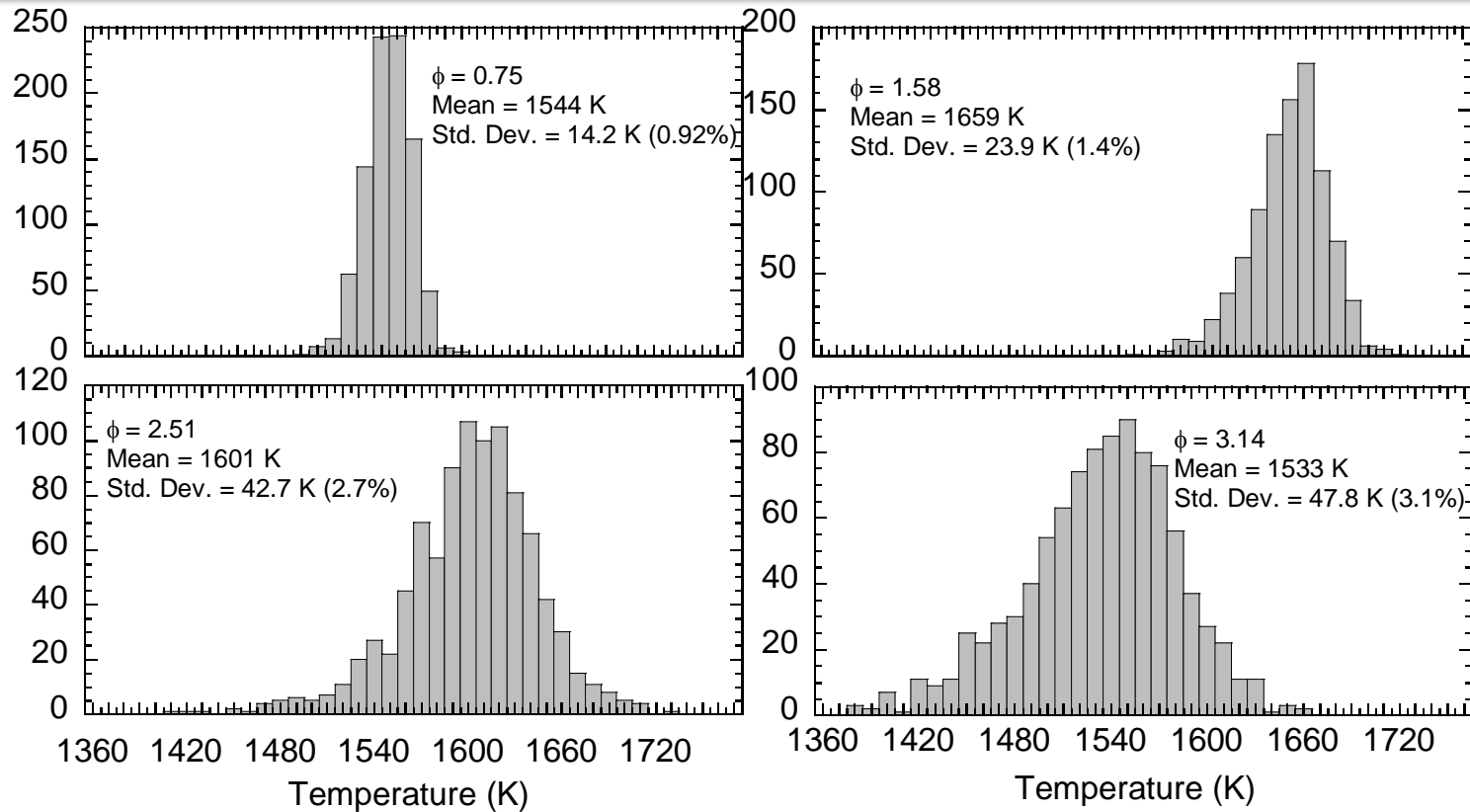

- Measurement volume positioned 11.5 mm above burner where flame is stable
- Minimal variation in temperature in this range of ϕ
- Precision is 0.9 to 1.4% in leanest flames investigated : CARS photon yields are highest
- Precision degrades to $\sim 3\%$ in richest flames
- Precision appears to be correlated to photon yield

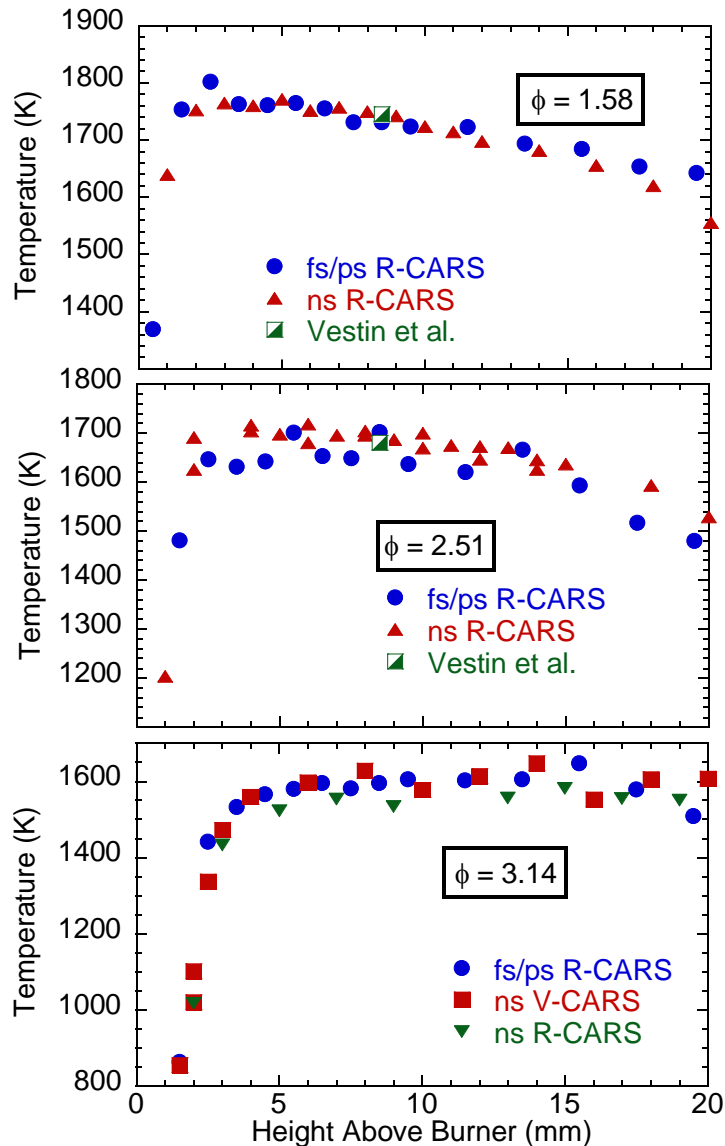

- Comparison is most valid in stable region 5-15 mm height
- ns-CARS temperatures based on fits to shot-averaged spectra
- Agreement of fs/ps and ns CARS is within 1-3% in these *fuel-rich, sooting* flames
- Within reported accuracy of rotational ns-CARS
- ns-CARS measurements
 - Rotational CARS at Sandia 11/2013
 - Vibrational CARS at Sandia (2006)
 - Rotational CARS at Lund (Vestin et al. 2005)

Summary and Conclusions

- High-energy probes generated via SHBC enable flame temperature measurements with rotational fs/ps CARS
- We have performed a **systematic assessment of accuracy and precision**
 - Near-adiabatic H₂/air flames
 - Premixed hydrocarbon air flames for $\phi = 0.75$ to 3.14
- Temperature accuracy is 3% for shot-averaged spectra, 3-6% for single-shot means
- Uncertainty in temperature standards is 3%
- Accuracy of O₂/N₂ ratio is 2-6% in H₂/air flames
- Temperature precision is outstanding!
 - As good as 1%
 - Periodic oscillations of 30 K (2%) amplitude realized in Hencken burner
 - Results suggest correlation of CARS signal photons to precision
- Precision of O₂/N₂ ratio is 1-10% and monotonically increases with O₂/N₂
- O₂/N₂ sensitivity arises from spectral envelope and not resolution of O₂ lines

Summary and Conclusions

- High-energy probes generated via SHBC enable flame temperature measurements with rotational fs/ps CARS
- We have performed a **systematic assessment of accuracy and precision**
 - Near-adiabatic H₂/air flames
 - Premixed hydrocarbon air flames for $\phi = 0.75$ to 3.14
- Temperature accuracy is 3% for shot-averaged spectra, 3-6% for single-shot means
- Uncertainty in temperature standards is 3%
- Accuracy of O₂/N₂ ratio is 2-6% in H₂/air flames
- Temperature precision is outstanding!
 - As good as 1%
 - Periodic oscillations of 30 K (2%) amplitude realized in Hencken burner
 - Results suggest correlation of CARS signal photons to precision
- Precision of O₂/N₂ ratio is 1-10% and monotonically increases with O₂/N₂
- O₂/N₂ sensitivity arises from spectral envelope and not resolution of O₂ lines

Time Gated Minimization of CO₂

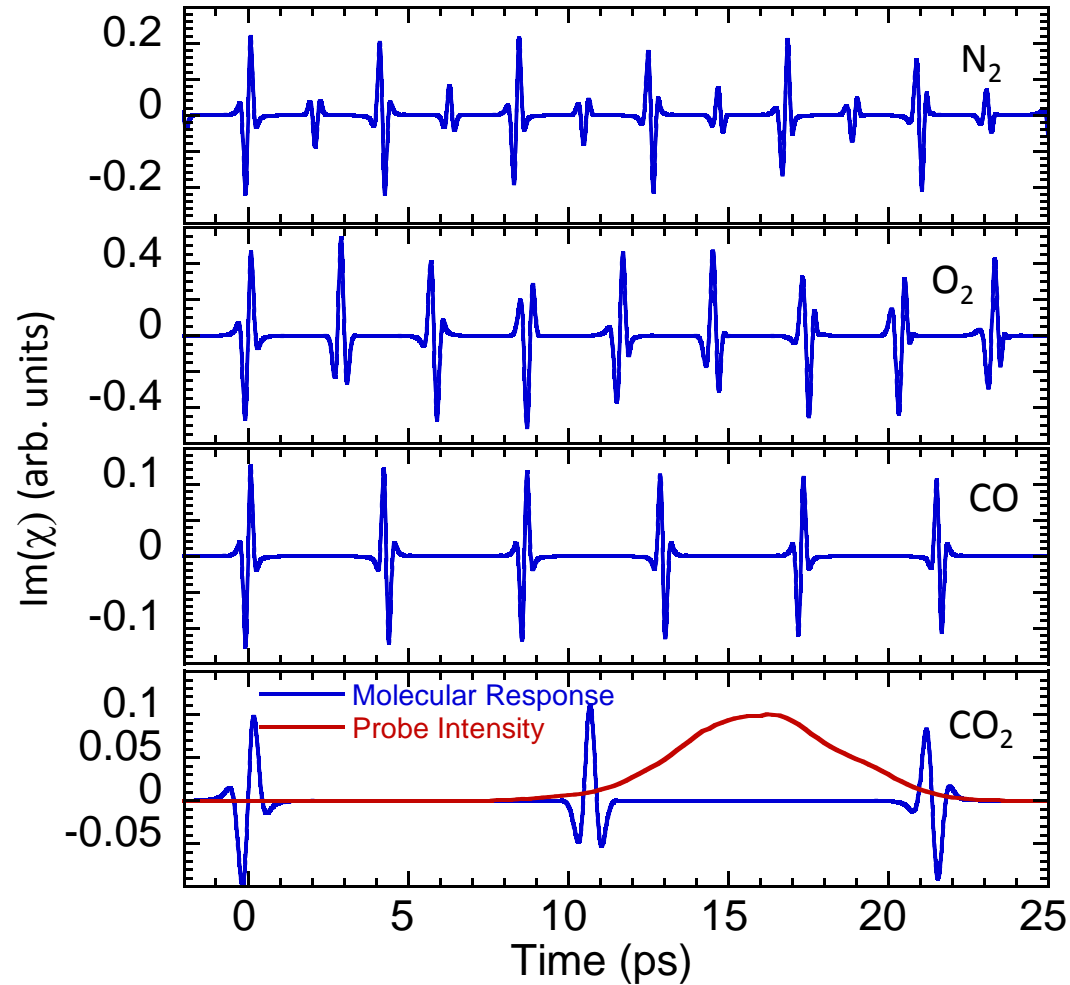

Low noise fs preparation pulses result can result in higher single-laser-shot precision

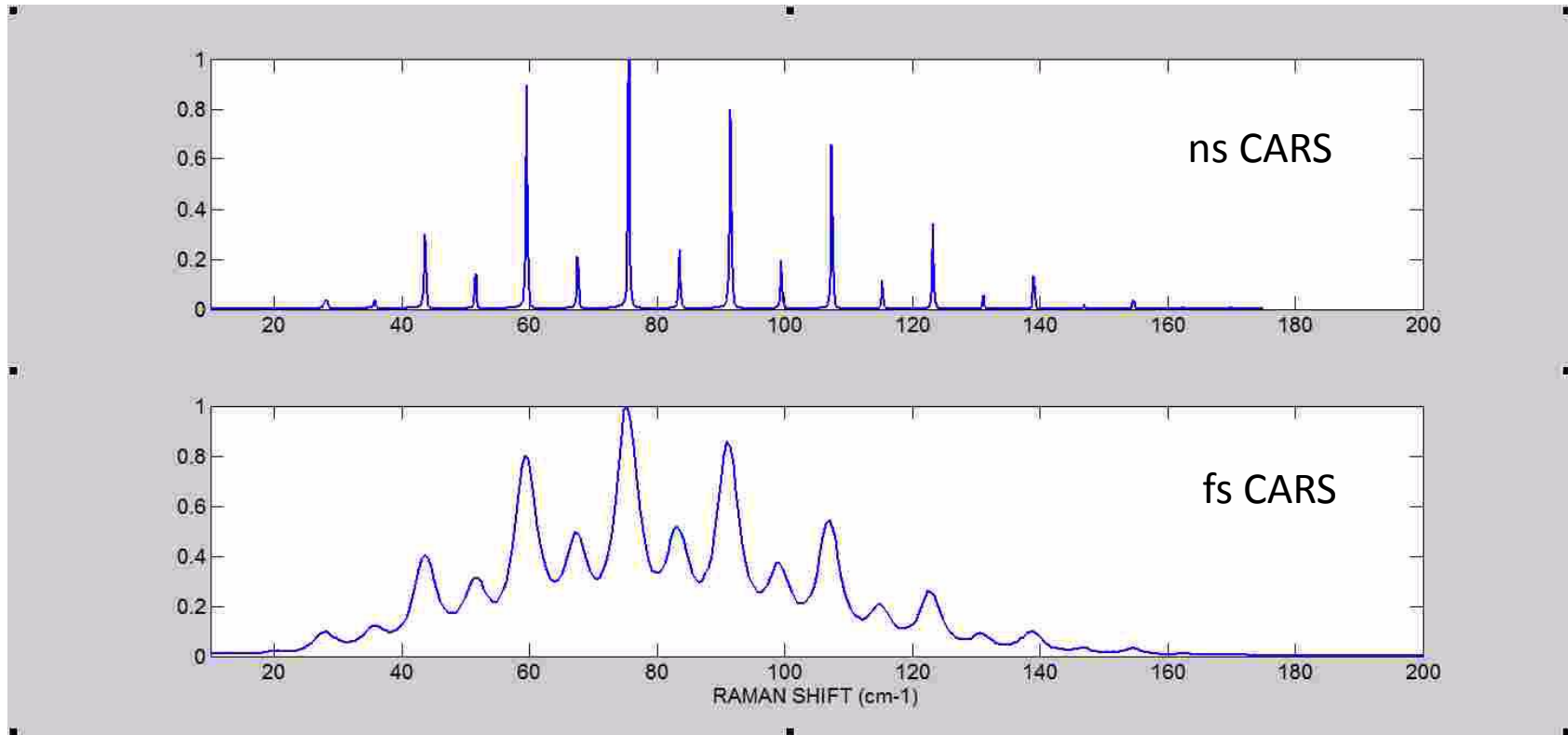

Room-temperature N_2 spectra

Pump Stokes Delay Shifts Bandwidth Center

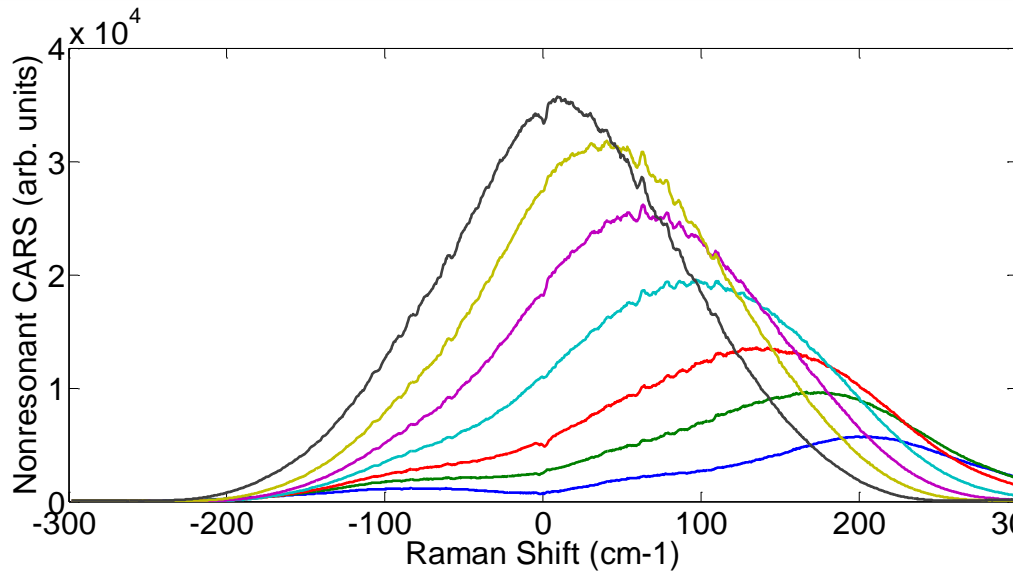

- Delay between pump and Stokes pulses shifts the peak signal
- Allows full utilization of limited bandwidth
- Increased signal for high-J transitions in flames
- 2-3× hit on peak nonresonant signal
- No apparent loss in total bandwidth

