

DOE / SNL Scaled Wind Farm Technology (SWiFT) Facility Overview

swift.sandia.gov

*Jonathan Berg, Josh Bryant, David Kroeker, Bruce
LeBlanc, David Maniaci, Brian Naughton, Josh
Paquette, Brian Resor, and Jonathan White*



SWiFT Facility

SWiFT exists to:

- Reduce turbine-turbine interaction and wind plant underperformance
- Develop advanced wind turbine rotors
- Public open-source to advance simulation capabilities



Facilities:

- Three variable-speed variable-pitch modified wind turbines with full power conversion and extensive sensor suite
- Two heavily instrumented inflow anemometer towers
- Site-wide time-synchronized data collection

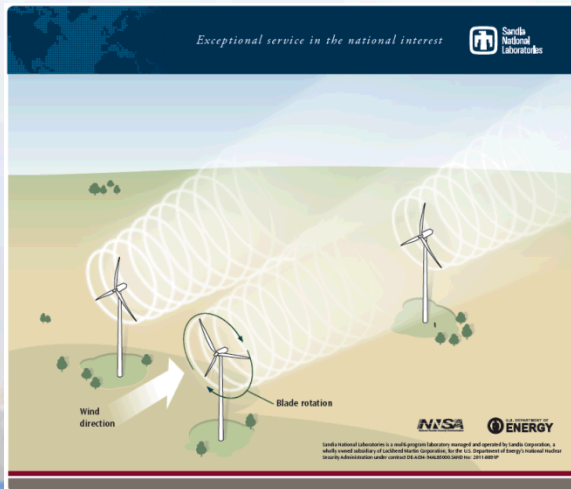

Similar Wind Farm-Specific Facilities



https://www.ecn.nl/fileadmin/ecn/units/wind/docs/EWTW/EWTW_b-08-014_br.pdf

Five Nordex N80 wind turbines owned by the test site



<http://www.marewint.eu/typo3temp/pics/20e1f7a940.jpg>



Outline

- **What is the SWiFT Facility?**
- **What research projects use SWiFT?**
- **How can I use SWiFT?**



Outline

- **What is the SWiFT Facility?**
- What research projects use SWiFT?
- How can I use SWiFT?



Location, Location, ... Location

United States - Annual Average Wind Speed at 80 m

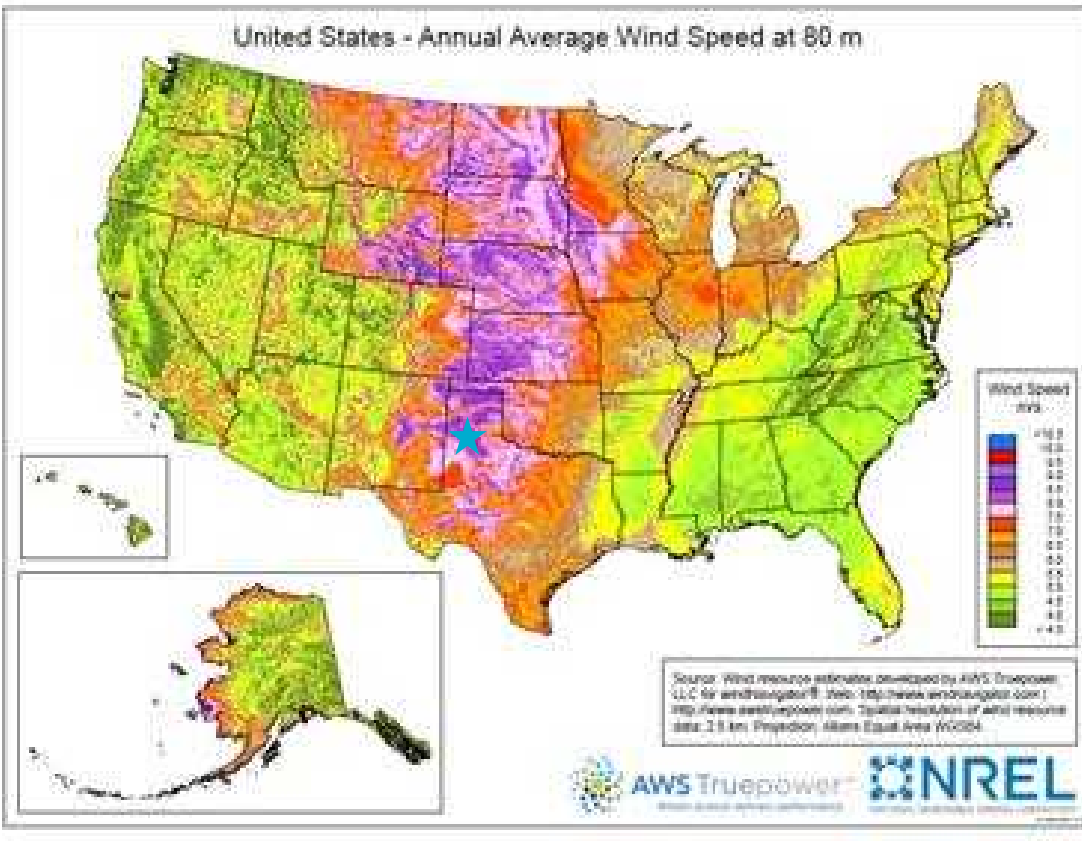

- 7.5 m/s at 50 m, Class 5 Wind Site!
- Consistent South Wind, 180.5° Average

Wind Frequency Rose (77 m)

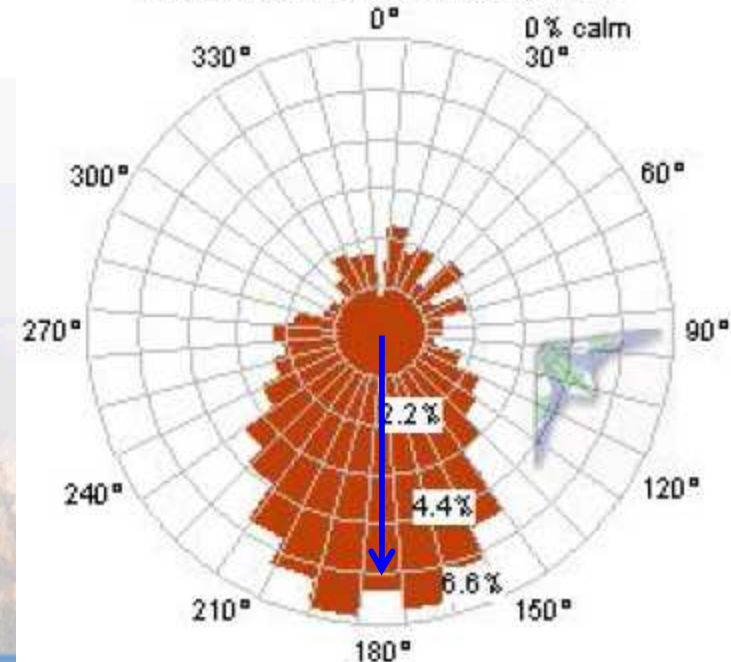

TEXAS TECH
UNIVERSITY

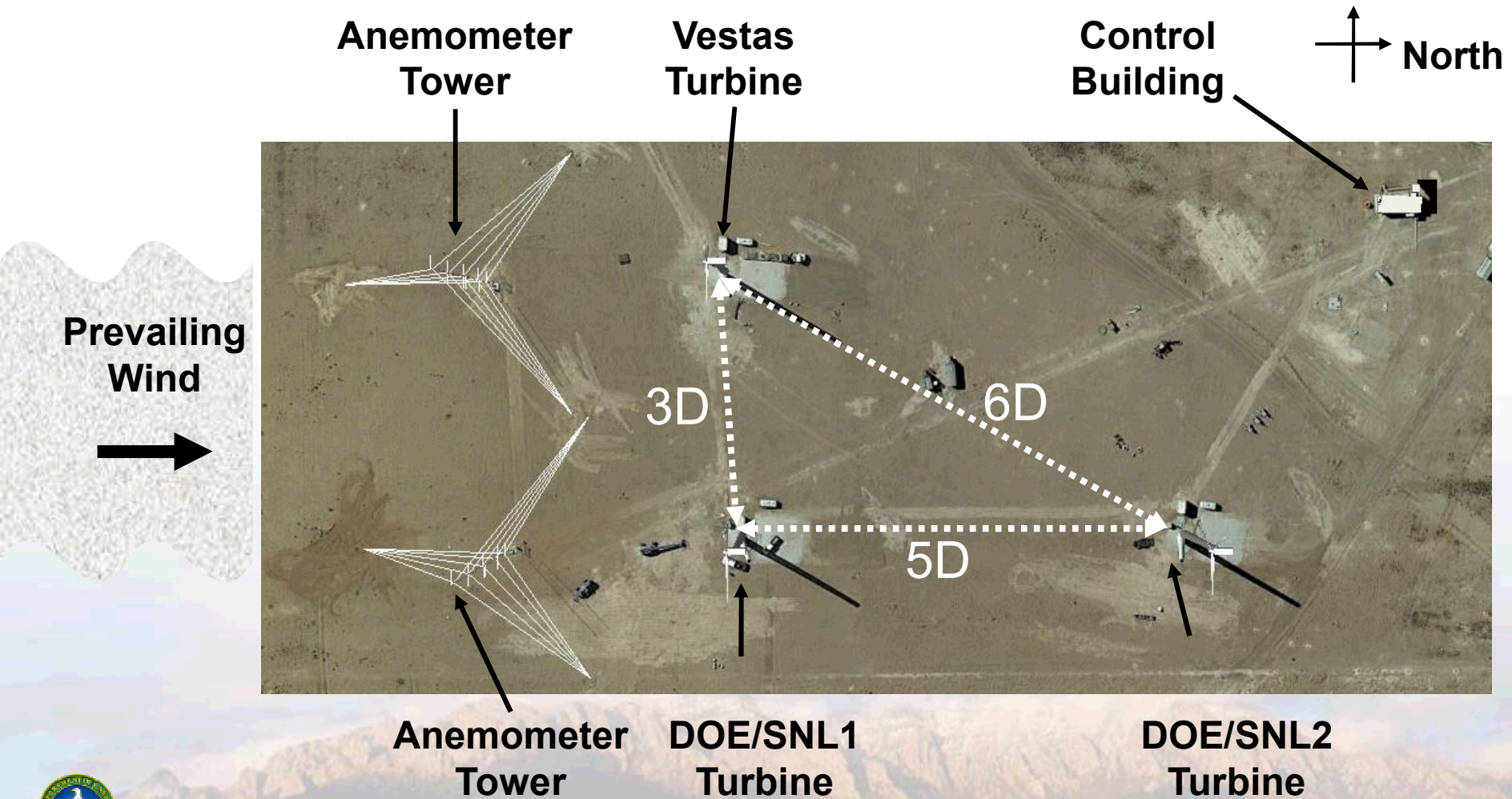

SWiFT Wind Turbines

Hardware

- Collective Pitch System
- 300 kW Variable Speed Generator
- AC-DC-AC Full Scale Converter
- National Instruments controllers
- Complete turbine / rotor state instrumentation
- Fiber Optic blade sensing system



Why this size?

Research-Scale



*Minimum research
cost and time*

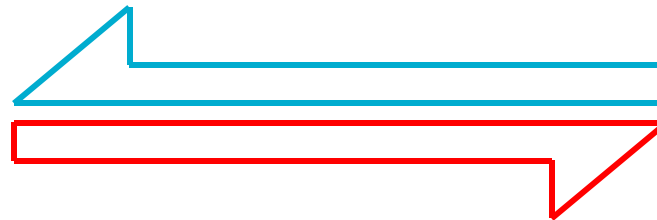

*Exact
Scaling*

Megawatt-Scale



- A cost-efficient size for which research can be directly scaled to larger, more costly and time-consuming sizes.
- Requirements:
 - Operation at Reynolds Number (scaling parameter) between 10^6 and 10^7
 - Tip speeds approaching 80 m/s for acoustics and large rotor projects
 - Variable-speed variable-pitch operation
 - Minimal cost and time associated with research operations
 - Highly reliable turbine
 - Minimal restrictions on publication and intellectual property



SWiFT Wind Turbines

Control Software

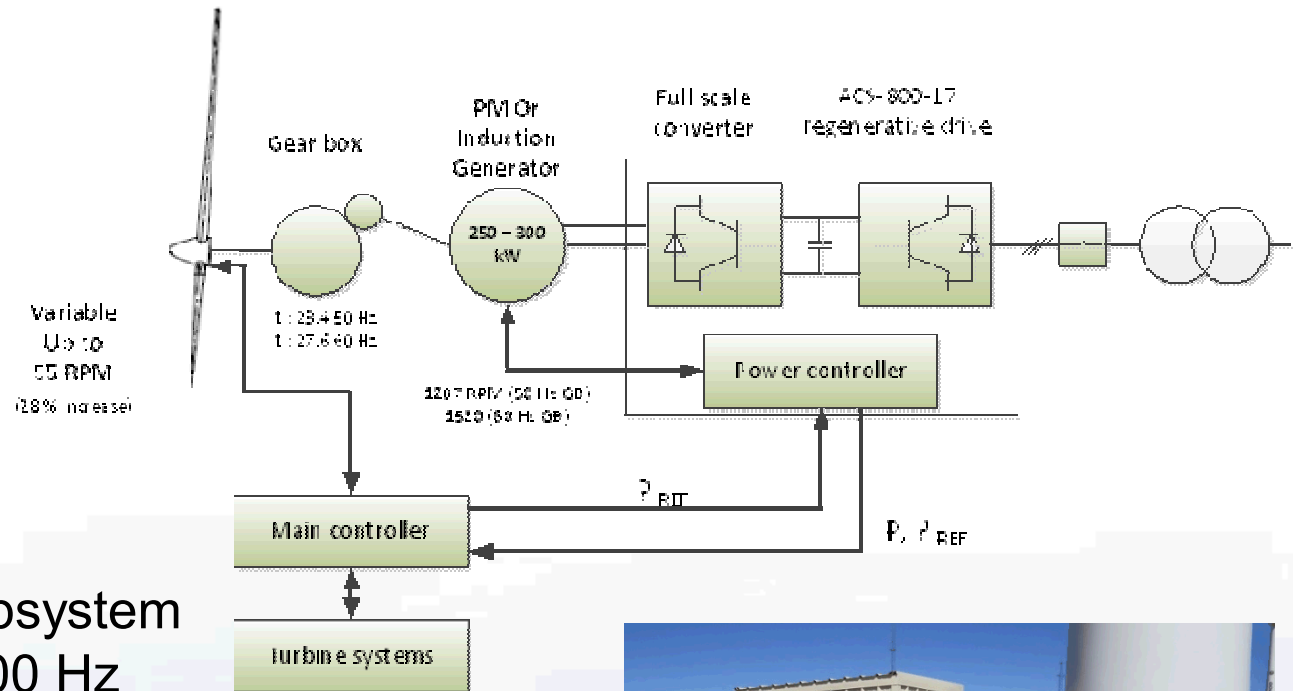
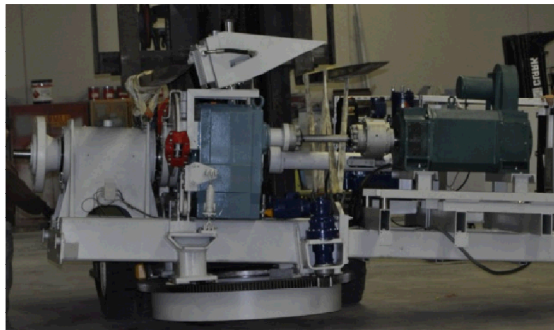

- Open Source Code
- Modularized by Subsystem
- EtherCAT up to 1000 Hz
- All DAQ signals available for control
- Running on NI Veristand
- Parameterized Variable Speed and Torque Controller
- Maintains all original safety systems and alarms



Inflow

Characterization

Met Mast Configuration

Experimental Research Test Site at Lubbock, Texas

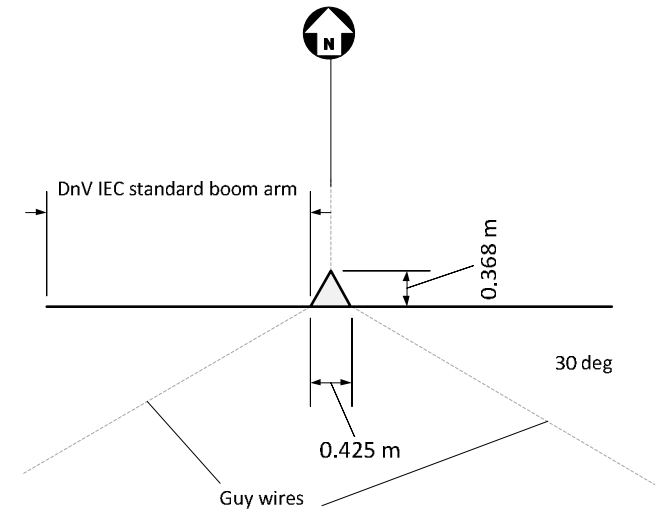
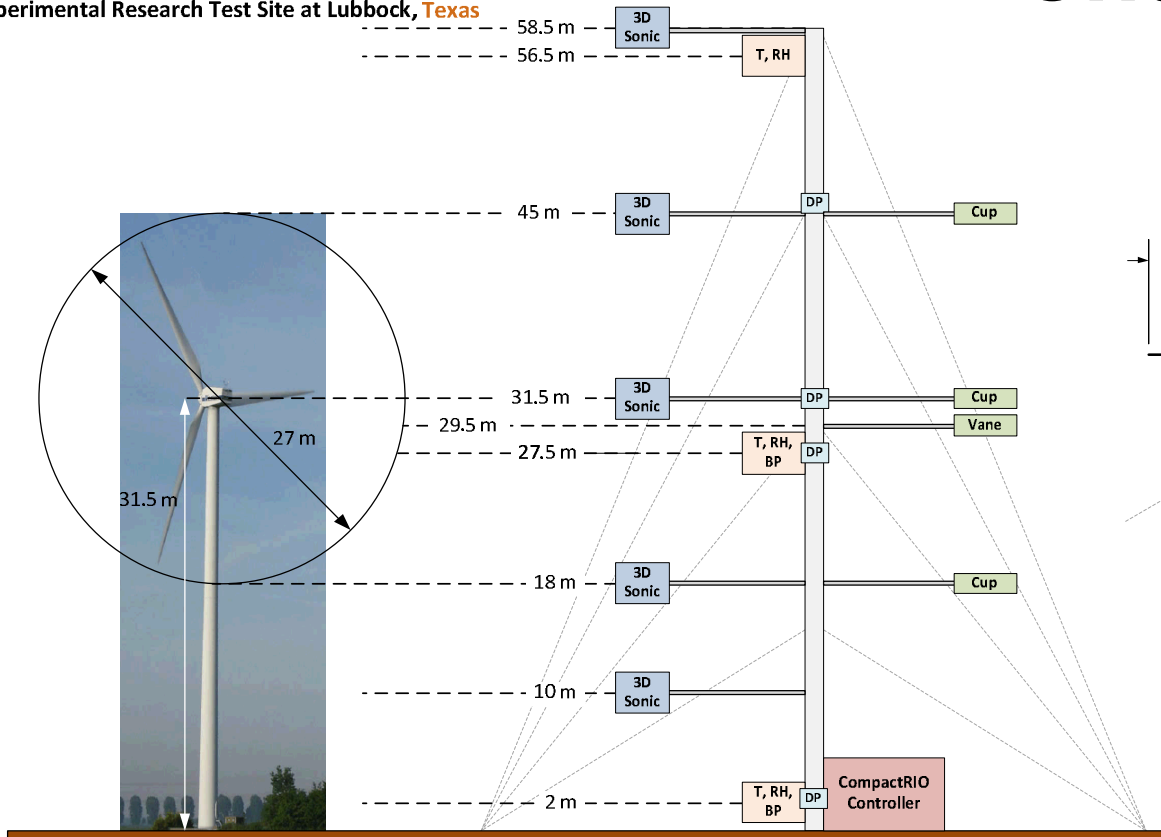

Met mast sensors

- 3D Sonic:** ATI SATI/3A Sonic Anemometer
- Cup:** Thies Wind Sensor First Class Advanced (IEC accredited)
- Vane:** Thies Wind Direction Sensor First Class
- T:** S92 Met One Temperature sensor
- BP:** 092 Met One Barometric Pressure sensor
- RH:** S93 Met One Relative Humidity sensor
- DP:** ATI PAD-401 DataPacker

Met mast heights*

- 58.5 m: 3D Sonic
- 56.5 m: T, RH
- 45 m: 3D Sonic, Cup
- 31.5 m: 3D Sonic, Cup
- 29.5 m: 3D Sonic, Vane
- 27.5 m: T, RH, BP
- 18 m: 3D Sonic, Cup
- 10 m: 3D Sonic
- 2 m: T, RH, BP

Guy wires Radius 47.5m

- 57.91 m
- 45.11 m
- 29.87 m
- 14.63 m



Networking Infrastructure

- GPS synced measurements
- Up to 1000 Hz
- Currently 500+ channels
- Centrally logged data
- Fiber optic data transfer
- Localized deterministic control loops

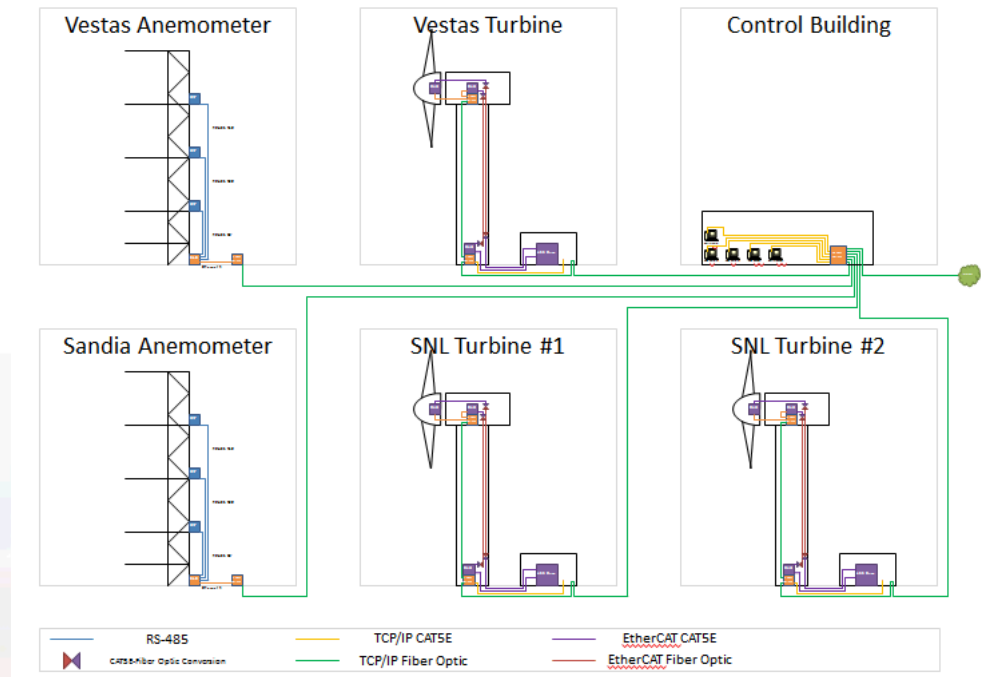

Control Building

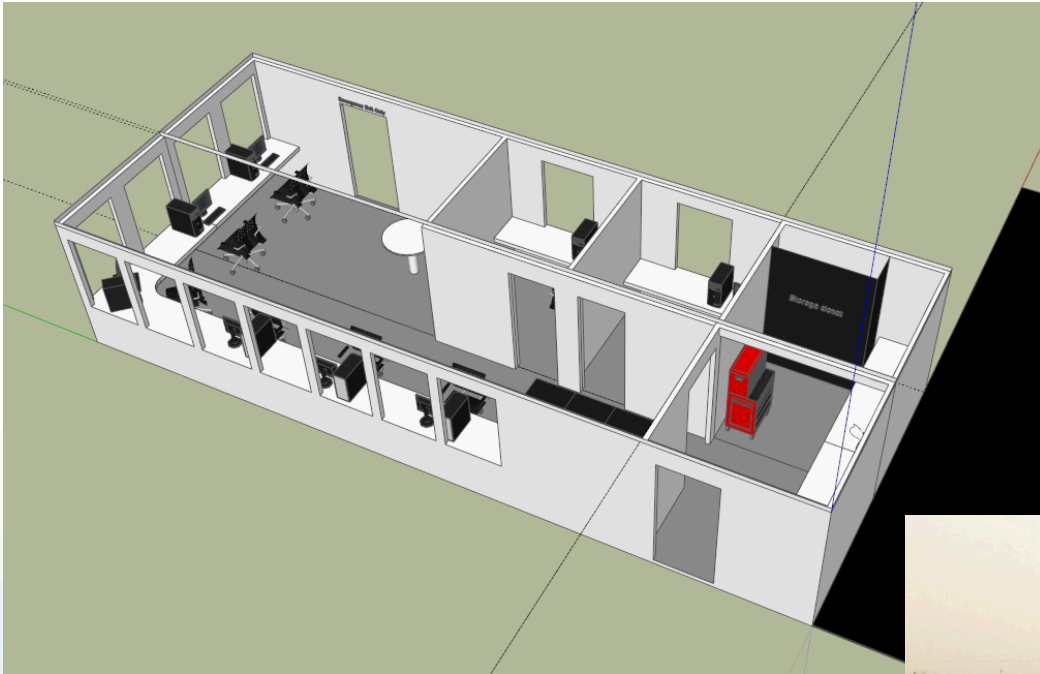

- Central control and operations
- 700 sq. ft. with 2 temporary offices for proprietary work
- Electrical troubleshooting lab



Experimental Preparation Lab



- 4,500 sq. ft. environmentally controlled high-bay experimental rotor preparation
- 1,000 sq. ft. machine shop



Outline

- What is the SWiFT Facility?
- **What research projects use SWiFT?**
- How can I use SWiFT?



SWiFT Baseline

- Detailed analysis of fundamental turbine-turbine interaction
- Calibration and verification of public open-source wind turbine / plant model
- Data quality analysis and troubleshooting



National Rotor Testbed

- The National Rotor Testbed is a rotor innovation to enable technology acceleration
- Baseline blades represent functionally scaled-down aerodynamics and structural dynamics of a modern megawatt-scale rotor
- Baseline blade design is public and open
- Enables research in: wake interactions, aero-acoustics, inboard aerodynamics, controls, aeroelastic dynamics

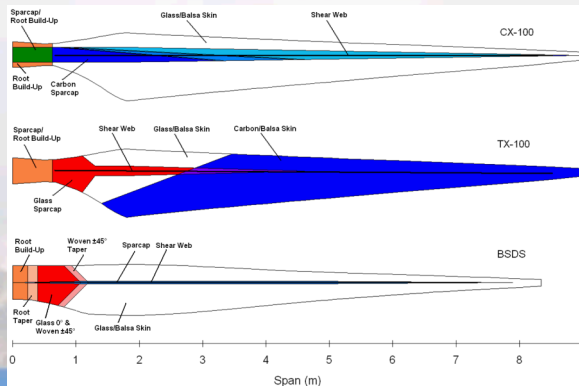
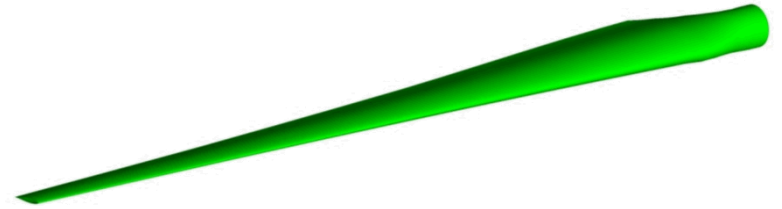

Wake Imaging Measurement System

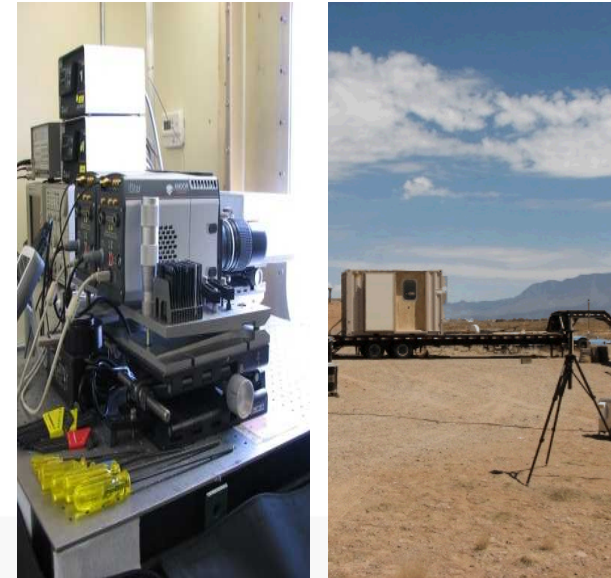
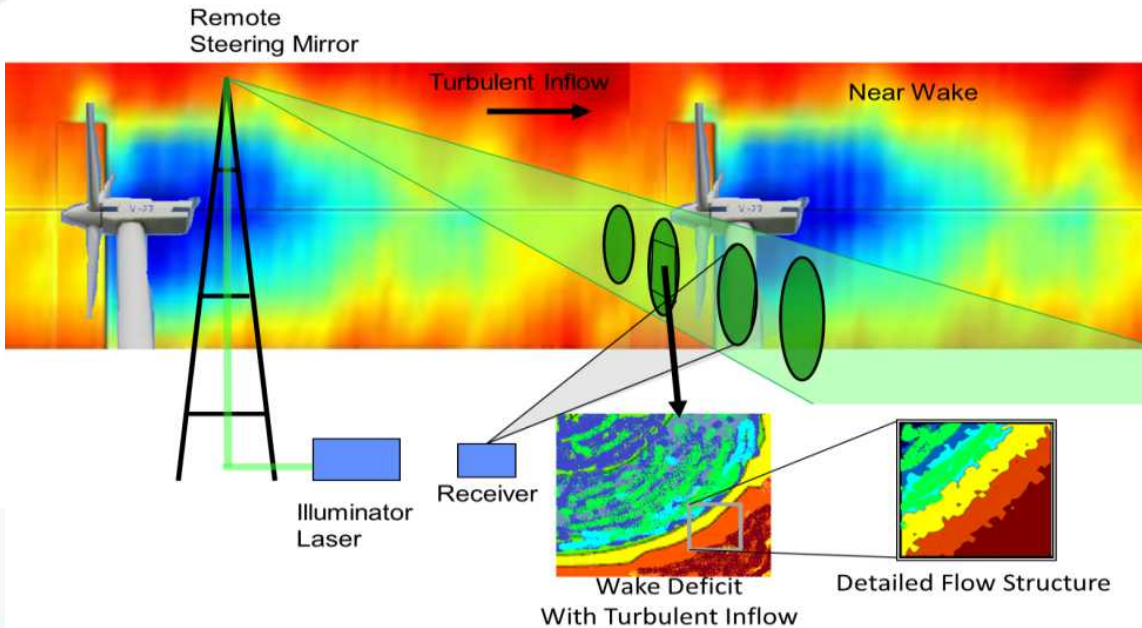

- Capture detailed 3-D flow structures that convect downwind
- High spatial resolution: 16,000 data points per sample
- Imaging allows for fast scanning sufficient to capture sub-rotor scale turbulent flow structures
- Enables direct comparison with high-fidelity and engineering level models



Outline

- **What is the SWiFT Facility?**
- **What research projects use SWiFT?**
- **How can I use SWiFT?**



How to partner

- SWiFT is open to all partnership opportunities:
 - Partners include industry, academia, laboratories, etc.
 - Facility has been designed to minimize research cost
 - Public, public / proprietary and solely proprietary all possible
 - Partnership agreements include:
 - Work For Others (WFO)
 - Collaborative Research and Development (CRADA)
 - Memorandum of Understanding (MOU)
 - Joint Funding Opportunities (FOA)

Partnership Examples



- **Vestas** installed a turbine owned by Vestas and managed by Sandia as a technology accelerator for their product development (rotors, acoustics, wind plant control)
- **National Instruments** is co-developing cRIO hardware and Veristand software for distributed control
- **ABB** is using power electronics equipment to improve wind market products

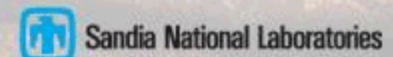
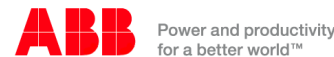



Thank you!



This work is supported by the US DOE EERE Wind and Water Power Program.