

# **Pilot-Scale Silicone Process for Low-Cost Carbon Dioxide Capture**

## **Preliminary Techno-Economic Analysis**

### **Topical Report**

Reporting Period Start Date: 1/1/2014

Reporting Period End Date: 03/31/2014

Surinder Singh, Irina Spiry, Benjamin Wood, Dan Hancu, Wei Chen  
GE Global Research  
1 Research Circle, Niskayuna, NY

Mark Kehmna, Dwayne McDuffie  
GE Power and Water  
1 River Road, Schenectady, NY

Date Report Issued: July 2014

DE-FE0013755 Task 2.2

## **Disclaimer:**

This report was prepared as an account of work sponsored by an agency of the United States Government. Neither the United States Government nor any agency thereof, nor any of their employees, makes any warranty, express or implied, or assumes any legal liability or responsibility for the accuracy, completeness, or usefulness of any information, apparatus, product, or process disclosed, or represents that its use would not infringe privately owned rights. Reference herein to any specific commercial product, process, or service by trade name, trademark, manufacturer, or otherwise does not necessarily constitute or imply its endorsement, recommendation, or favoring by the United States Government or any agency thereof. The views and opinions of authors expressed herein do not necessarily state or reflect those of the United States Government or any agency thereof.

## Abstract:

This report presents system and economic analysis for a carbon-capture unit which uses an aminosilicone-based solvent for CO<sub>2</sub> capture in a pulverized coal (PC) boiler. The aminosilicone solvent is a 60/40 wt/wt mixture of 3-aminopropyl end-capped polydimethylsiloxane (GAP-1m) with tri-ethylene glycol (TEG) as a co-solvent. For comparison purposes, the report also shows results for a carbon-capture unit based on a conventional approach using mono-ethanol amine (MEA).

The first year removal cost of CO<sub>2</sub> for the aminosilicone-based carbon-capture process is \$46.04/ton of CO<sub>2</sub> as compared to \$60.25/ton of CO<sub>2</sub> when MEA is used. The aminosilicone-based process has <77% of the CAPEX of a system using MEA solvent. The lower CAPEX is due to several factors, including the higher working capacity of the aminosilicone solvent compared the MEA, which reduces the solvent flow rate required, reducing equipment sizes. If it is determined that carbon steel can be used in the rich-lean heat exchanger in the carbon capture unit, the first year removal cost of CO<sub>2</sub> decreases to \$44.12/ton. The aminosilicone-based solvent has a higher thermal stability than MEA, allowing desorption to be conducted at higher temperatures and pressures, decreasing the number of compressor stages needed. The aminosilicone-based solvent also has a lower vapor pressure, allowing the desorption to be conducted in a continuous-stirred tank reactor versus a more expensive packed column. The aminosilicone-based solvent has a lower heat capacity, which decreases the heat load on the desorber. In summary, the amino-silicone solvent has significant advantages over conventional systems using MEA.

# Table of Contents

	Page
<b>Executive Summary</b>	1
<b>Task 2.2: Preliminary Techno-Economic Analysis</b>	2
Process Description	2
Power Plant Modeling	4
CO <sub>2</sub> -Capture System ASPEN Plus Model Development	18
Studies of Integrated Power Plant with CO <sub>2</sub> -Capture Plant	36
Economic Analysis	53
Sensitivity Analysis	59
<b>Conclusions</b>	63

## Executive Summary:

This report presents system and economic analysis for a carbon-capture unit which uses an aminosilicone-based solvent for CO<sub>2</sub> capture and sequestration (CCS) for a pulverized coal (PC) power plant. The aminosilicone-based solvent is a 60/40 wt/wt mixture of 3-aminopropyl end-capped polydimethylsiloxane (GAP-1m) with tri-ethylene glycol (TEG) as a co-solvent. For comparison purposes, the report also shows results for a CCS unit based on a conventional approach using mono-ethanol amine (MEA).

Aspen Plus models were developed for both the MEA and aminosilicone-based CO<sub>2</sub> separation units to calculate the mass and energy balances and system performance. The models account for steam load for the CO<sub>2</sub> separation units and parasitic loads for solvent pumps, CO<sub>2</sub> compressors, and cooling water pumps. The power plant was modeled using Thermoflow.

The first year removal cost of CO<sub>2</sub> for the aminosilicone-based carbon-capture process is \$46.04/ton of CO<sub>2</sub> as compared to \$60.25/ton of CO<sub>2</sub> when MEA is used. The aminosilicone-based process has <77% of the CAPEX of a system using MEA solvent. The lower CAPEX is due to several factors, including the higher working capacity of the aminosilicone-based solvent compared to MEA, which reduces the solvent flow rate required, reducing equipment sizes. If it is determined that carbon steel can be used in the rich-lean heat exchanger in the carbon capture unit, the first year removal cost of CO<sub>2</sub> decreases to \$44.12/ton. The aminosilicone-based solvent has a higher thermal stability than MEA, allowing desorption to be conducted at higher temperatures and pressures, decreasing the number of compressor stages needed. The aminosilicone-based solvent also has a lower vapor pressure, allowing the desorption to be conducted in a continuous-stirred tank reactor versus a more expensive packed column. The aminosilicone-based solvent has a lower heat capacity, which decreases the heat load on the desorber. In summary, the amino-silicone solvent has significant advantages over conventional systems using MEA.

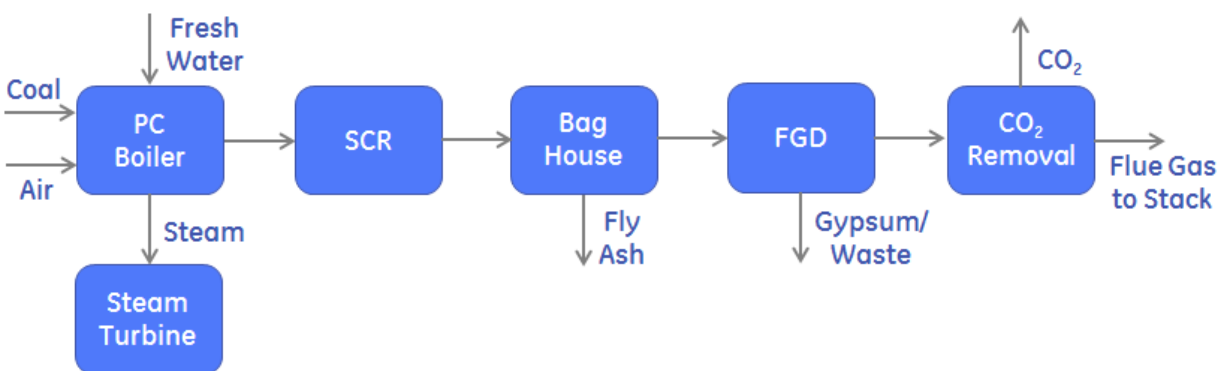
## Completion of Task 2.2: Preliminary Techno-Economic Analysis

The primary objective of this cooperative agreement is to design, construct, and operate a pilot-scale process using a novel aminosilicone-based CO<sub>2</sub>-capture solvent. The project will design and build a pilot-scale CO<sub>2</sub>-capture process that utilizes an aminosilicone-based solvent system, composed of 60/40 wt/wt 3-aminopropyl end-capped polydimethylsiloxane (GAP-1m)/triethylene glycol (TEG) developed in a previous DOE award (DE-NT0005310). The design of the pilot-scale system will be based on data obtained in another DOE award (DE-FE0007502). The pilot-scale system will be installed at the National Carbon Capture Center (NCCC) and the aminosilicone-based solvent system will be tested in this system. This cooperative agreement will demonstrate an aminosilicone-based CO<sub>2</sub>-capture solvent for post-combustion capture of CO<sub>2</sub> from coal-fired power plants at less than \$40/tonne (\$36/ton) of CO<sub>2</sub> captured with 90% CO<sub>2</sub> capture and 95% CO<sub>2</sub> purity.

### Process Description

A supercritical pulverized coal (PC) plant and CO<sub>2</sub>-separation unit based on mono-ethanol amine (MEA) is described in Case 12 of the DOE Bituminous Baseline Study.<sup>1</sup>

A simplified block diagram of the power plant and CO<sub>2</sub>-separation system is shown in Figure 1. The pulverized coal boiler generates steam, which is sent to the steam turbines. The flue gas is sent through a selective catalytic reduction (SCR) unit to reduce nitrogen oxides (NO<sub>x</sub>), a bag house to remove fly ash, and a flue gas desulfurizer (FGD) to remove sulfur dioxide. The flue gas is then sent through the carbon dioxide separation unit before being vented to the stack.

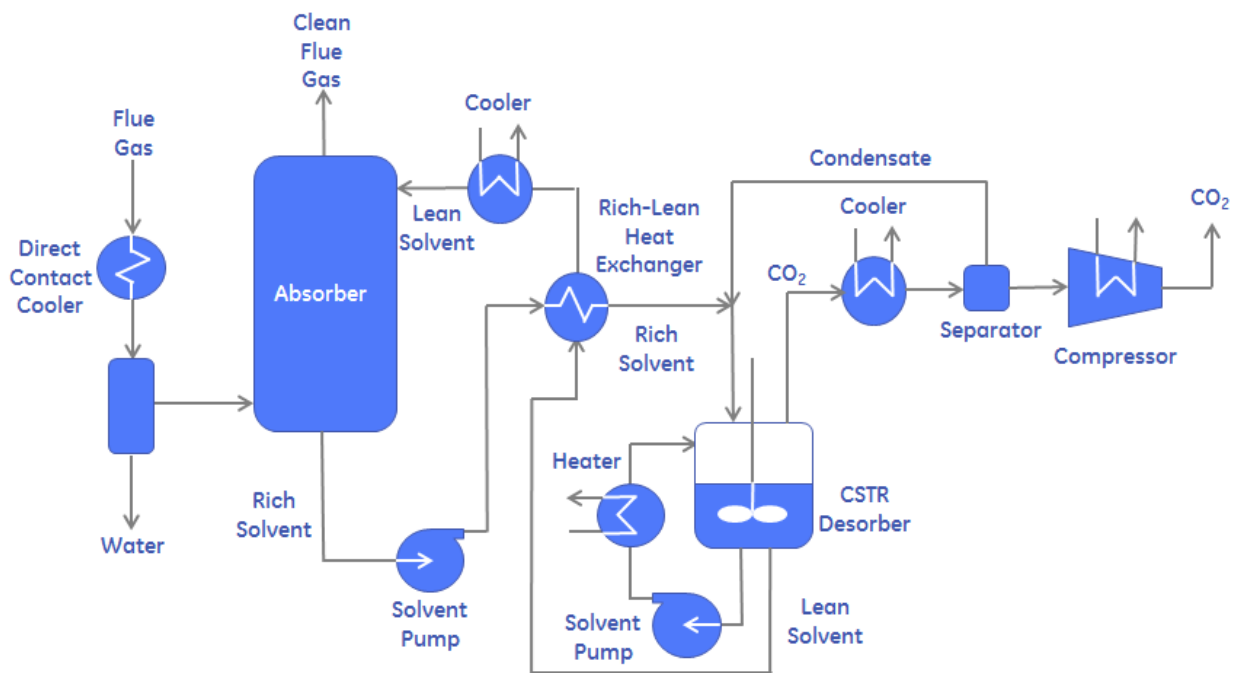


**Figure 1.** Coal-fired power plant block diagram with CO<sub>2</sub> removal.

<sup>1</sup> "Cost and Performance Baseline for Fossil Energy Plants - Volume 1: Bituminous Coal and Natural Gas to Electricity (Rev 2, November 2010)", DOE/2010/1397.

The MEA and GAP-1/TEG CO<sub>2</sub> separation units utilize four key processes, CO<sub>2</sub> absorption, CO<sub>2</sub> desorption, sorbent handling, and CO<sub>2</sub> compression.

The flue gas from the power plant is processed in a direct contact cooler to reduce the temperature to 40 °C (104 °F) and then enters the absorber. Figure 2 shows the process for the aminosilicone case. The lean sorbent enters the absorber at 40 °C (104 °F) and captures most of the CO<sub>2</sub> from the flue gas. The rich sorbent leaves the absorber. The CO<sub>2</sub> absorption increases the temperature of the sorbent. The absorber is operated at 40-82 °C (104-180 °F) and at atmospheric pressure. The rich sorbent from the absorber is fed to the rich-lean heat exchanger and heated before being fed to the desorber (stripper) for separation of the absorbed CO<sub>2</sub>. A 11.1 °C (20 °F) approach is assumed for this rich-lean heat exchanger. This is defined as the hot fluid outlet temperature minus the cold fluid inlet temperature. The lean sorbent from the desorber is passed through the other side of the rich-lean heat exchanger.



**Figure 2.** Aminosilicone-based CO<sub>2</sub> separation sub-system.

For the aminosilicone solvent baseline case (Case A, described below), the desorber operates at 140 °C (284 °F) and 4.3 atm (63 psia). For the sensitivity studies, the desorber conditions were varied from 130 to 140 °C (266 to 284 °F) and from 1.4 to 4.3 atm (20 to 63 psia). These results are presented in subsequent sections. For the MEA baseline case, the desorber reboiler

conditions are about 116 °C (241 °F) and 1.6 atm (24 psia). For both systems, steam is supplied to the desorber to provide heat, which releases CO<sub>2</sub> from the rich sorbent. Steam is supplied from the medium- to low-pressure steam turbine crossover pipe of the steam turbine in the power plant sub-system. Steam conditions were selected based on best efficiency of the power plant and the removal cost of CO<sub>2</sub> from the overall system. The hot vapor from the top of the desorber consisting primarily of CO<sub>2</sub> is cooled in a heat exchanger utilizing water. The stream then flows to a separator where the vapor and entrained liquid are separated. The CO<sub>2</sub> gas is removed from the separator and then delivered to the CO<sub>2</sub> product compressor. The liquid from the bottom of the separator is returned back to the desorber. The lean sorbent from the desorber is pumped through the rich-lean heat exchanger to the absorber. The lean sorbent is cooled further before being fed to the absorber in order to increase the loading of CO<sub>2</sub> in the absorber.

## **Power Plant Modeling**

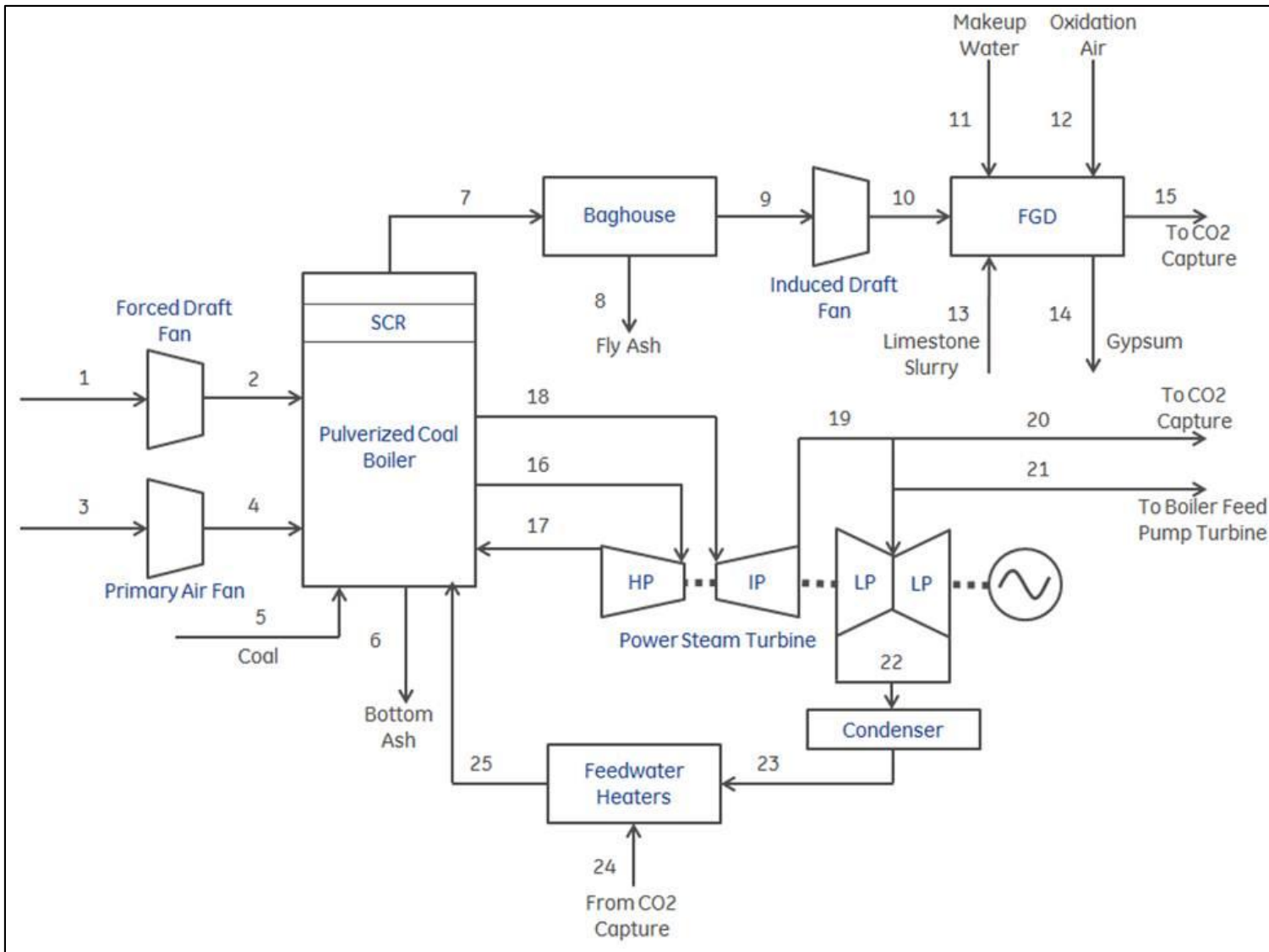
A model of a supercritical PC plant was built in Thermoflow, a thermodynamic design tool which includes cost estimation methods for conventional coal power plants. The Thermoflow model interacted with the carbon-capture model by exchanging flue gas, process steam, and water at the boundaries between the two systems. Capital costs, operating costs, and net power output were rolled up at a plant level.

The modeling process began by calibrating to Case 11 from the Bituminous Baseline Study.<sup>1</sup> Gas and steam flows, pressures and temperatures throughout the plant, along with exhaust composition, auxiliary loads, and net plant output were closely matched to Case 11 to create a calibration point for the model in Thermoflow. By matching to Case 11 it was possible to replicate efficiency levels on all of the major equipment in the power block, including pumps, fans, steam turbine sections, the boiler, and environmental equipment. These efficiencies were then held fixed as the model was updated to include CO<sub>2</sub>-capture, thus ensuring consistency between the DOE report and the analysis with carbon capture. It was also possible to tune the cost model in Thermoflow to achieve a good match for overall capital costs with Case 11 from the Bituminous Baseline Study. The cost breakdown in Thermoflow's cost estimation tool is not at the same level of detail as in the Bituminous Baseline Study, so when calibrating the plant capital costs it was necessary to calibrate only on the full plant level rather than on a component level.

Figure 3 shows a simplified block diagram of the power block, which is applicable to both the model with CO<sub>2</sub> capture and without. Detailed process flow information for each stream in Figure 3 is shown in Table 1 for the model without CO<sub>2</sub> capture. This model is intended to be a close match with Case 11 from the Bituminous Baseline Study.



Power plant modeling was conducted in Thermoflow for a number of cases. As described above, the first case was similar to Case 11 in the DOE Bituminous Baseline Study which is for a supercritical PC plant without CO<sub>2</sub> capture. Secondly, a Thermoflow model was built for a scaled up system for 550 MW net power with a CO<sub>2</sub>-capture system added. For this case, the power plant model was built in Thermoflow and the carbon-capture island was modeled in Aspen Plus and Aspen Capital Cost Estimator. The scaled-up model is Case H which will be discussed in the next sections.



**Figure 3:** Block flow diagram for power plant.

**Table 1.** Stream table for power plant case without CO<sub>2</sub> capture (comparable to Case 11).<sup>1</sup>

	1	2	3	4	5	6	7
V-L Mole Fraction							
Ar	0.0093	0.0093	0.0093	0.0093	0.0000	0.0000	0.0088
CO <sub>2</sub>	0.0003	0.0003	0.0003	0.0003	0.0000	0.0000	0.1485
H <sub>2</sub>	0.0000	0.0000	0.0000	0.0000	0.0000	0.0000	0.0000
H <sub>2</sub> O	0.0101	0.0101	0.0101	0.0101	0.0000	0.0000	0.0893
N <sub>2</sub>	0.7729	0.7729	0.7729	0.7729	0.0000	0.0000	0.7310
O <sub>2</sub>	0.2074	0.2074	0.2074	0.2074	0.0000	0.0000	0.0202
SO <sub>2</sub>	0.0000	0.0000	0.0000	0.0000	0.0000	0.0000	0.0022
Total	1.0000	1.0000	1.0000	1.0000	0.0000	0.0000	1.0000
V-L Flowrate (lbmol/hr)	106,097	106,097	32,592	32,592	-	-	146,883
V-L Flowrate (lb/hr)	3,061,401	3,061,401	940,431	940,431	-	-	4,371,358
Solids Flowrate (lb/hr)	-	-	-	-	410,264	8,142	32,568.79
Temperature (°F)	59	65	59	77	59	-	342
Pressure (psia)	14.7	15.1	14.7	16.2	14.7	-	14.3
Enthalpy (Btu/lbm)	-4.3	-3.0	-4.3	0.1	-	-	69.2
Density (lb/ft <sup>3</sup> )	0.076	0.078	0.076	0.081	-	-	0.047
V-L Molecular Weight	28.85	28.85	28.85	28.85	-	-	29.76

	8	9	10	11	12	13	14
V-L Mole Fraction							
Ar	0.0000	0.0088	0.0088	0.0000	0.0093	0.0000	0.0000
CO <sub>2</sub>	0.0000	0.1485	0.1485	0.0000	0.0003	0.0000	0.0004
H <sub>2</sub>	0.0000	0.0000	0.0000	0.0000	0.0000	0.0000	0.0000
H <sub>2</sub> O	0.0000	0.0893	0.0893	1.0000	0.0101	1.0000	0.9996
N <sub>2</sub>	0.0000	0.7310	0.7310	0.0000	0.7729	0.0000	0.0000
O <sub>2</sub>	0.0000	0.0202	0.0202	0.0000	0.2074	0.0000	0.0000
SO <sub>2</sub>	0.0000	0.0022	0.0022	0.0000	0.0000	0.0000	0.0000
Total	0.0000	1.0000	1.0000	1.0000	1.0000	1.0000	1.0000
V-L Flowrate (lbmol/hr)	-	146,883	146,883	15,884	2,284	8,483	348
V-L Flowrate (lb/hr)	-	4,371,358	4,371,358	286,236	65,916	152,864	6,264
Solids Flowrate (lb/hr)	32,569	-	-	-	-	33,832	56,664
Temperature (°F)	-	342	362.9	59	59	59	0
Pressure (psia)	-	13.84	15.06	14.7	14.7	14.7	0.0
Enthalpy (Btu/lbm)	-	69.2	74.7	27.1	-4.3	-	-
Density (lb/ft <sup>3</sup> )	-	0.046	0.048	62.379	0.076	-	-
V-L Molecular Weight	-	29.76	29.76	18.02	28.85	-	18.03

	15	16	17	18	19	20	21
V-L Mole Fraction							
Ar	0.0081	0.0000	0.0000	0.0000	0.0000	0.0000	0.0000
CO <sub>2</sub>	0.1372	0.0000	0.0000	0.0000	0.0000	0.0000	0.0000
H <sub>2</sub>	0.0000	0.0000	0.0000	0.0000	0.0000	0.0000	0.0000
H <sub>2</sub> O	0.1575	1.0000	1.0000	1.0000	1.0000	1.0000	1.0000
N <sub>2</sub>	0.6767	0.0000	0.0000	0.0000	0.0000	0.0000	0.0000
O <sub>2</sub>	0.0203	0.0000	0.0000	0.0000	0.0000	0.0000	0.0000
SO <sub>2</sub>	0.0000	0.0000	0.0000	0.0000	0.0000	0.0000	0.0000
Total	1.0000	1.0000	1.0000	1.0000	1.0000	1.0000	1.0000
V-L Flowrate (lbmol/hr)	161,275	203,480	168,736	168,736	152,819	-	12,899
V-L Flowrate (lb/hr)	4,646,871	3,666,712	3,040,619	3,040,619	2,753,799	-	232,437
Solids Flowrate (lb/hr)	-	-	-	-	-	-	-
Temperature (°F)	132	1100	664	1100	688	-	688
Pressure (psia)	14.7	3514.7	693.7	655.8	134.9	-	134.9
Enthalpy (Btu/lbm)	14.8	1495.0	1323.7	1570.5	1371.4	-	1371.4
Density (lb/ft <sup>3</sup> )	0.063	4.319	1.141	0.722	0.200	-	0.200
V-L Molecular Weight	28.81	18.02	18.02	18.02	18.02	-	18.02

	22	23	24	25
V-L Mole Fraction				
Ar	0.0000	0.0000	0.0000	0.0000
CO <sub>2</sub>	0.0000	0.0000	0.0000	0.0000
H <sub>2</sub>	0.0000	0.0000	0.0000	0.0000
H <sub>2</sub> O	1.0000	1.0000	1.0000	1.0000
N <sub>2</sub>	0.0000	0.0000	0.0000	0.0000
O <sub>2</sub>	0.0000	0.0000	0.0000	0.0000
SO <sub>2</sub>	0.0000	0.0000	0.0000	0.0000
Total	1.0000	1.0000	1.0000	1.0000
V-L Flowrate (lbmol/hr)	114,800	154,153	-	203,480
V-L Flowrate (lb/hr)	2,068,688	2,777,829	-	3,666,712
Solids Flowrate (lb/hr)	-	-	-	-
Temperature (°F)	101	104	-	557
Pressure (psia)	1.0	264.2	-	4185.2
Enthalpy (Btu/lbm)	1016.3	72.3	-	552.9
Density (lb/ft <sup>3</sup> )	0.003	61.999	-	47.687
V-L Molecular Weight	18.02	18.02	-	18.02

Table 2 summarizes the power output from the power plant, without CO<sub>2</sub> capture, along with materials consumed during normal operation. It includes a detailed summary of auxiliary loads and how they combine with the steam turbine power to impact the total plant net-power output and efficiency. Auxiliary loads required only minor tuning in order to conform to the results from DOE Case 11.<sup>1</sup>

**Table 2.** Power summary for case without CO<sub>2</sub> capture (comparable to DOE Case 11).<sup>1</sup>

<b>POWER SUMMARY (Gross Power at Generator Terminals, kWe)</b>	
Steam Turbine Power	580,418
<b>Total (Steam Turbine) Power, kWe</b>	<b>580,418</b>
<b>Auxiliary Load Summary, kWe</b>	
Boiler Fuel Delivery	3,216
Ash Handling	529
Primary Air Fans	1,358
Forced Draft Fans	1,524
Induced Draft Fans	7,444
Baghouse (ESP)	70
Wet FGD	5,536
Carbon-Capture Process	-
CO <sub>2</sub> Compression	-
Miscellaneous BOP	289
Condensate Pumps	953
Circulating Water Pumps	3,889
Cooling Tower Fans	3,284
Transformer Losses	1,820
BFP Booster Pump	498
<b>Total Auxiliaries, kWe</b>	<b>30,411</b>
<b>Net Power, kWe</b>	<b>550,008</b>
Net Plant Efficiency (HHV)	39.2%
Net Plant Heat Rate, (Btu/kWh)	8,702
<b>Condenser Cooling duty, (10<sup>6</sup> Btu/hr)</b>	<b>2,212</b>
<b>Consumables</b>	
As-Received Coal Feed, (lb/hr)	410,264
Limestone Sorbent Feed, (lb/hr)	33,833
Thermal Input (kWt)	1,402,678
Raw Water Consumption (gpm)	6,740

The Thermoflow model includes a cost estimation tool. The results from this are summarized in Table 3. The cost estimates for the model without carbon capture were tuned in order to line

up with the results from Case 11 in the economic updates (June 2011 Basis) for the Bituminous Baseline Study.<sup>2</sup> The factors that were applied in order to achieve this match were held constant for further analysis of cases with CO<sub>2</sub> capture.

**Table 3.** Equipment cost summary for case without CO<sub>2</sub> capture (comparable to DOE Case 11).<sup>2</sup>

	\$	\$/kW
<b>Specialized Equipment</b>	<b>\$ 503,571,680</b>	<b>\$ 912</b>
<b>Boiler</b>	<b>\$ 190,948,513</b>	<b>\$ 346</b>
Furnace	\$ 81,914,520	\$ 148
Convective Elements	\$ 55,081,043	\$ 100
Additional Waterwall	\$ 5,734,579	\$ 10
Soot Blowers	\$ 4,858,259	\$ 9
Desuperheaters and Controls	\$ 8,363,538	\$ 15
Air and Flue Gas Ducts	\$ 5,955,797	\$ 11
Coal Pulverizers and Feeders	\$ 19,589,477	\$ 35
FD Fan, PA Fan, ID Fan	\$ 3,079,953	\$ 5.6
Structural Steel, Ladders, Walkways	\$ 2,481,073	\$ 4.5
Rotary Air Heaters	\$ 3,887,829	\$ 7.0
	\$ -	\$ -
<b>Steam Turbine</b>	<b>\$ 112,162,148</b>	<b>\$ 203</b>
<b>Feedwater Heaters</b>	<b>\$ 9,790,217</b>	<b>\$ 18</b>
Feedwater Heater 1	\$ 706,216	\$ 1.3
Feedwater Heater 2	\$ 677,982	\$ 1.2
Feedwater Heater 3	\$ 631,536	\$ 1.1
Feedwater Heater 4	\$ 813,651	\$ 1.5
Feedwater Heater 5-DA	\$ 954,821	\$ 1.7
Feedwater Heater 6 (6A,6B)	\$ 1,665,926	\$ 3.0
Feedwater Heater 7 (7A,7B)	\$ 2,205,182	\$ 4.0
Feedwater Heater 8 (8A,8B)	\$ 2,135,025	\$ 3.9
<b>Water Cooled Condensers</b>	<b>\$ 4,703,533</b>	<b>\$ 8.5</b>
Main Condenser	\$ 4,138,816	\$ 7.5
Feed Pump Turbine Condenser	\$ 565,023	\$ 1.0
<b>Particulate and Mercury Control</b>	<b>\$ 22,139,295</b>	<b>\$ 40</b>
<b>Flue Gas Desulfurization</b>	<b>\$ 87,523,161</b>	<b>\$ 159</b>

<sup>2</sup> "Updated Costs (June 2011 Basis) for Selected Bituminous Baseline Cases", DOE/NETL-341/082312.



<b>Nitrogen Oxide Control (SCR)</b>	<b>\$ 39,389,787</b>	<b>\$ 71</b>
<b>Stack</b>	<b>\$ 9,447,807</b>	<b>\$ 17</b>
<b>Continuous Emissions Monitoring System</b>	<b>\$ 627,299</b>	<b>\$ 1.1</b>
<b>Distributed Control System</b>	<b>\$ 1,675,191</b>	<b>\$ 3.0</b>
<b>Transmission Voltage Equipment</b>	<b>\$ 15,090,301</b>	<b>\$ 27</b>
Transformers	\$ 13,353,578	\$ 24
Circuit Breakers	\$ 1,018,812	\$ 1.8
Miscellaneous Equipment	\$ 718,644	\$ 1.3
<b>Generating Voltage Equipment</b>	<b>\$ 10,074,427</b>	<b>\$ 18</b>
Generator Buswork	\$ 5,234,596	\$ 9
Circuit Breakers	\$ 4,359,515	\$ 7.9
Miscellaneous Equipment	\$ 479,706	\$ 0.9

<b>Other Equipment</b>	<b>\$ 126,556,231</b>	<b>\$ 229</b>
<b>Pumps</b>	<b>\$ 12,782,669</b>	<b>\$ 23</b>
Boiler Feed Pump (+ Turbine)	\$ 8,445,190	\$ 15
Boiler Feed Booster Pump	\$ 130,955	\$ 0.2
Condenser C.W. Pump	\$ 2,290,345	\$ 4.1
Condensate Forwarding Pump	\$ 599,474	\$ 1.1
Condenser Vacuum Pump	\$ 373,495	\$ 0.7
Aux Cooling Water Pump (Closed Loop)	\$ 40,050	\$ 0.1
Treated Water Pump	\$ 6,783	\$ 0.01
Diesel Fire Pump	\$ 172,876	\$ 0.3
Jockey Fire Pump	\$ 5,182	\$ 0.01
Demin Water Pump	\$ 13,419	\$ 0.02
Raw Water Pumps	\$ 28,232	\$ 0.1
Aux Cooling Water Pump (Open Loop)	\$ 40,050	\$ 0.1
Startup Boiler Feed Pump	\$ 637,239	\$ 1.2
<b>Tanks</b>	<b>\$ 960,883</b>	<b>\$ 1.7</b>
Hydrous Ammonia	\$ 160,595	\$ 0.3
Demin Water	\$ 104,252	\$ 0.2
Raw Water	\$ 340,440	\$ 0.6
Neutralized Water	\$ 78,037	\$ 0.1

Acid Storage	\$ 32,620	\$ 0.1
Caustic Storage	\$ 32,620	\$ 0.1
Dedicated Fire Protection Water Storage	\$ 212,355	\$ 0.4
	\$ -	\$ -
<b>Cooling Tower</b>	<b>\$ 10,215,077</b>	<b>\$ 19</b>
<b>Auxiliary Cooling Water Heat Exchanger</b>	<b>\$ 138,904</b>	<b>\$ 0.3</b>
<b>Steam Turbine Crane</b>	<b>\$ 1,984,621</b>	<b>\$ 3.6</b>
<b>Station Instrument Air Compressors</b>	<b>\$ 816,256</b>	<b>\$ 1.5</b>
<b>General Plant Instrumentation</b>	<b>\$ 430,632</b>	<b>\$ 0.8</b>
<b>Medium Voltage Equipment</b>	<b>\$ 6,408,794</b>	<b>\$ 12</b>
Transformers	\$ 908,452	\$ 1.6
Circuit Breakers	\$ 344,459	\$ 0.6
Switchgear	\$ 1,805,415	\$ 3.3
Motor Control Centers	\$ 3,044,880	\$ 5.5
Miscellaneous	\$ 305,221	\$ 0.6
<b>Low Voltage Equipment</b>	<b>\$ 1,577,221</b>	<b>\$ 2.9</b>
Transformers	\$ 550,622	\$ 1.0
Circuit Breakers	\$ 460,216	\$ 0.8
Motor Control Centers	\$ 491,003	\$ 0.9
Miscellaneous	\$ 751,898	\$ 1.4
<b>Coal Handling Equipment</b>	<b>\$ 62,983,114</b>	<b>\$ 114</b>
<b>Ash Handling Equipment</b>	<b>\$ 22,231,445</b>	<b>\$ 40</b>
<b>Miscellaneous Equipment</b>	<b>\$ 6,026,614</b>	<b>\$ 11</b>

<b>Civil</b>	<b>\$ 82,771,128</b>	<b>\$ 150</b>
<b>Site Work</b>	<b>\$ 17,302,872</b>	<b>\$ 31</b>
<b>Excavation and Backfill</b>	<b>\$ 4,839,333</b>	<b>\$ 9</b>
<b>Concrete</b>	<b>\$ 59,554,161</b>	<b>\$ 108</b>
<b>Roads Parking and Walkways</b>	<b>\$ 1,074,761</b>	<b>\$ 1.9</b>

<b>Mechanical</b>	<b>\$ 249,878,964</b>	<b>\$ 453</b>
On Site Transportation and Rigging	\$ 8,948,256	\$ 16
Equipment Erection and Assembly	\$ 179,486,985	\$ 325
Piping	\$ 59,145,791	\$ 107
Steel	\$ 2,297,932	\$ 4.2

<b>Electrical Assembly and Wiring</b>	<b>\$ 22,045,205</b>	<b>\$ 40</b>
Controls	\$ 13,696,410	\$ 25
Assembly and Wiring	\$ 8,348,796	\$ 15

<b>Buildings and Structures</b>	<b>\$ 20,288,854</b>	<b>\$ 37</b>
Boiler House and Turbine Hall	\$ 18,282,573	\$ 33
Administration Control Room, Machine Shop, Warehouse	\$ 1,979,771	\$ 3.6
Guard House	\$ 26,510	\$ 0.05

<b>Engineering and Plant Startup</b>	<b>\$ 52,908,687</b>	<b>\$ 96</b>
Engineering	\$ 43,097,130	\$ 78
Start Up	\$ 9,811,557	\$ 18

<b>Totals</b>		
<b>Subtotal Contractor's Internal Cost</b>	<b>\$ 1,058,020,749</b>	<b>\$ 1,917</b>
Contractors Soft & Misc Costs	\$ 200,206,199	\$ 363
<b>Subtotal Contractor's Price</b>	<b>\$ 1,258,226,948</b>	<b>\$ 2,279</b>
Owner's Soft and Misc Costs	\$ 267,642,586	\$ 485
<b>Total Owner's Cost</b>	<b>\$ 1,525,869,535</b>	<b>\$ 2,764</b>

Details about consumable materials are also available from the Thermoflow model. These were used with unit cost values from the economic updates (June 2011 Basis) for the Bituminous Baseline Study in order to calculate annual costs of consumables and fuel.<sup>2</sup> The fixed operating costs and maintenance material costs were not independently calculated by the power block model and were therefore assumed equal to the values in DOE Case 11 to avoid inconsistency. The annual cost figures are summarized in Table 4.

**Table 4.** Annual cost summary for case without CO<sub>2</sub> capture (comparable to DOE Case 11).<sup>1</sup>

				Annual Cost	Annual Unit Cost
				\$	\$/kWh-net
<b>Fixed Operating Costs</b>				<b>\$ 38,828,811</b>	<b>\$ 0.00806</b>
<b>Maintenance Material Costs</b>				\$ 10,945,892	\$ 0.00227
	Consumption / day	Unit Cost			
Water (/1000 gallons)	3,293	1.67	\$ 1,706,242	\$ 0.00035	
Chemicals					
MU & WT Chem. (lbs)	15,939	0.27	\$ 1,335,191	\$ 0.00028	
Limestone (ton)	478	33.48	\$ 4,961,323	\$ 0.00103	
Ammonia (19% NH <sub>3</sub> ) ton	74	330	\$ 7,589,915	\$ 0.00158	
<b>Subtotal Chemicals</b>				<b>\$ 13,886,429</b>	<b>\$ 0.00288</b>
Other					
SCR Catalyst (m <sup>3</sup> )	0.31	5775.94	\$ 556,513	\$ 0.00012	
<b>Subtotal Other</b>				<b>\$ 556,513</b>	<b>\$ 0.00012</b>
Waste Disposal					
Total Ash (ton)	478	25.11	\$ 3,720,271	\$ 0.00077	
<b>Subtotal Waste Disposal</b>				<b>\$ 3,720,271</b>	<b>\$ 0.00077</b>
<b>Total Variable Operating Costs</b>				<b>\$ 19,869,457</b>	<b>\$ 0.00412</b>
Fuel (ton)	4923	68.60	\$ 104,780,439	\$ 0.02175	

Table 5 details the energy flows in and out of the control volume in the power block model, and confirms that the model achieves a proper energy balance.

**Table 5.** Energy balance for case without CO<sub>2</sub> capture (comparable to DOE Case 11).<sup>1</sup>

	HHV	Sensible + Latent Heat	Power	Total
Heat In (MMBtu/hr)				
Coal	4797			4797
Ambient Air		53.3		53.3
FGD Water		22.0		22.0
FGD Oxidation Air		3.8		3.8
Totals	4797	79		4876
Heat Out (MMBtu/hr)				
Bottom Ash		4.4		4.4
Fly Ash + FGD Ash		1.7		1.7
Flue Gas		611		611
Unburned Carbon		13.3		13.3
Boiler Losses		42.1		42.1
Fuel Delivery Losses		2.2		2.2
Main Condenser		1970		1970
BFPT Condenser		230		230
Steam Piping Losses		11.1		11.1
ST/Generator Mech/Elec/Gear Losses		22.7		22.7
BFPT Mech Losses		0.7		0.7
Pumps Mech/Elec Losses		2.4		2.4
Fans Mech/Elec Losses		3.8		3.8
FGD Energy Losses		31.7		31.7
Misc Losses and Auxiliaries		52.6		52.6
Net Power			1877	1877
Totals	0	2999	1877	4876

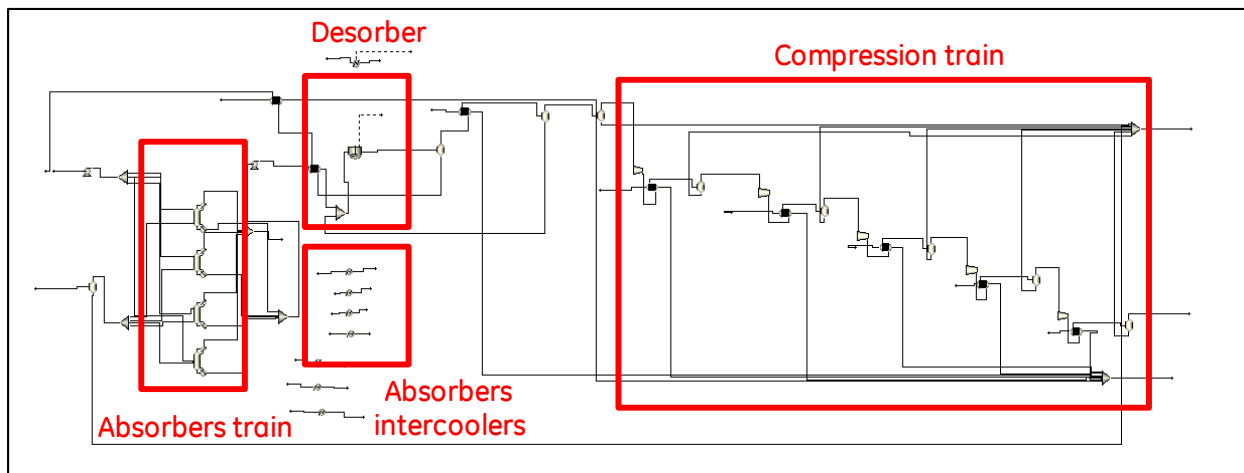
Table 6 summarizes the pieces of equipment which contribute to the total water consumption in the power block model.

**Table 6.** Water consumption for case without CO<sub>2</sub> capture (comparable to DOE Case 11).<sup>1</sup>

Water Use	Water Consumption (gpm)
Carbon-Capture Process	
FGD Makeup	573
Cooling Tower	3,558
<b>Total</b>	<b>4,130</b>

## CO<sub>2</sub>-Capture System ASPEN Plus Model Development

An ASPEN Plus model was developed for a supercritical commercial-scale process with aminosilicone-based solvent. The base case chosen was similar to Case 11 in the DOE-NETL study.<sup>1</sup> Models were developed for a number of different CO<sub>2</sub>-capture cases with varying absorber and desorber operating conditions. In order to compare the different cases of the carbon-capture island, the flue gas flow rate was fixed to match the Case 11 from the DOE NETL study which produces 550 MW net power without CO<sub>2</sub> capture. Comparing these cases facilitated final selection of the best case that had the lowest overall removal cost of CO<sub>2</sub>. The best case was then scaled up to 550 MW net power with CO<sub>2</sub> capture. Further, two more cases were modeled starting from the scaled-up best case to further optimize the power plant and the carbon-capture island integration. The details of the selected cases are explained in the subsequent sections. The overview of the model is presented in Figure 4.

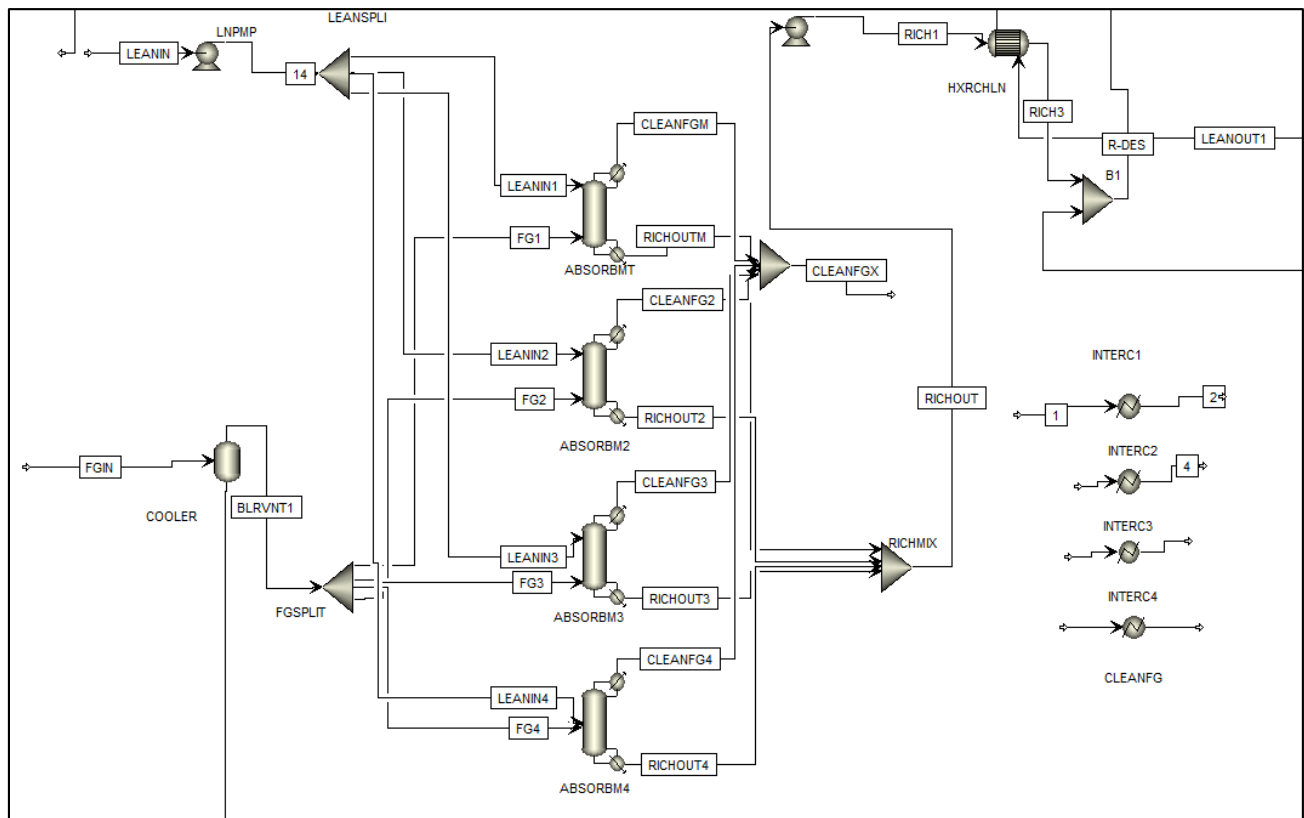


**Figure 4:** Aspen Plus model for CO<sub>2</sub> separation sub-system.

Each part of the process will be discussed below.

## Absorber Design

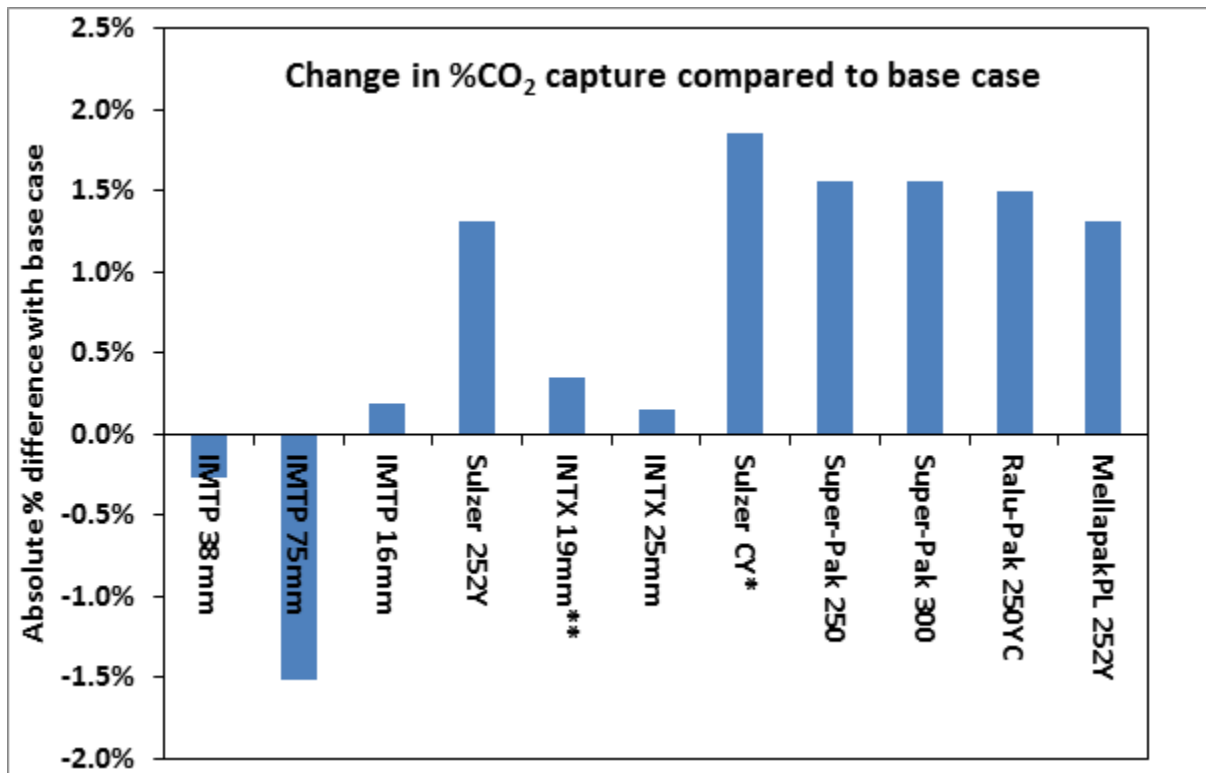
The CO<sub>2</sub>-capture process was designed for a supercritical PC power plant, and the best case was scaled up to achieve 550 MW of net power with CO<sub>2</sub> capture. Flue gas enters the post-combustion CO<sub>2</sub>-capture island from the coal power plant. The flue gas flow rate and composition were determined from the results of the power plant model using Thermoflow. The flue gas is cooled to 40 °C in a direct contact cooler, where condensed water is removed and sent to a waste water treatment plant. The absorber train consists of 4 units, and flue gas is evenly split among each of the columns. The flow sheet from the ASPEN Plus model of the absorber train is shown in Figure 5.



**Figure 5.** Aspen Plus flow sheet for the absorber train portion of the carbon-capture process.

The absorbers are designed as RadFrac unit operations in Aspen Plus, where mass transfer is modeled based on rate-based calculations and chemical reactions are assumed to be in equilibrium. These assumptions were made based on bench-scale experiments conducted in the prior award (DE-FE0007502).

During the last cooperative agreement, an ASPEN Plus model for the bench-scale process was developed, and the packing type used in the model for the absorber corresponded to the actual packing used in the bench-scale process. Because there is a range of choices for packing type for commercial-scale processes, sensitivity analysis was conducted with respect to packing type in order to understand its effect on system performance. This analysis was conducted at a fixed lean solvent flow rate to the absorber train, and the change in CO<sub>2</sub> capture was determined. Results of this sensitivity analysis are shown on Figure 6.



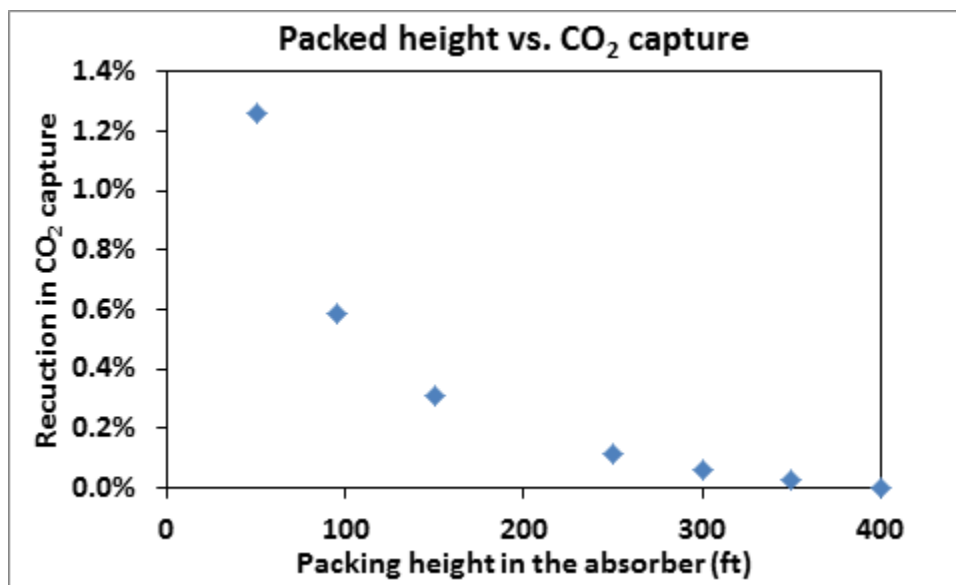
**Figure 6.** Effect of packing type on percent of CO<sub>2</sub> captured.

It can be seen that, overall, structured packing offers higher performance compared to random packing for this system. The best case shown provides ~2% improvement in capture efficiency compared to the base case. The packing type which is available at the NCCC is Mellapak Plus 252Y, and therefore this packing was selected for further analysis. Also, this packing is commercially available in carbon steel (CS), which is significantly less expensive than stainless steel (SS). Because of the aminosilicone's lower corrosivity relative to other solvents, carbon steel packing may be used.



## Packing Height Sensitivity Analysis

The sensitivity analysis with respect to packing height was conducted for Mellapak Plus 252Y structured packing, and the results are presented in Figure 7. It can be seen the reduction of packing height from 95 ft to 50 ft reduces the absolute value of CO<sub>2</sub> capture by ~0.6%, and therefore the lean solvent flow rate would need to be increased slightly to obtain 90% capture. The height of the packing was selected to be 50 ft, because the capital cost of the absorber train offsets the cost of a small lean-solvent flow rate increase. Diameter of each absorber was optimized to avoid flooding, and it was determined to be 33 ft for the final cases.



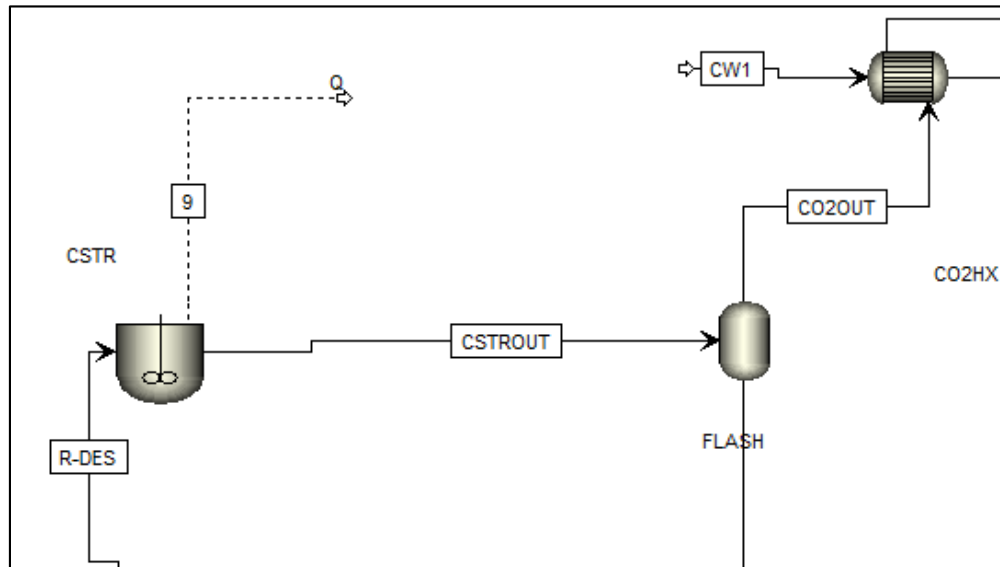
**Figure 7.** The effect of packing height on CO<sub>2</sub> capture.

## Desorber Design

It was previously shown that the aminosilicone-based solvent has significantly lower vapor pressure compared to MEA, and this property facilitates operating the desorption process at higher temperatures and pressures without significant solvent losses. This advantageous property also enables the desorption of CO<sub>2</sub> to be accomplished in a continuous stirred-tank reactor (CSTR) versus a distillation column, which reduces the CAPEX of the desorber system by ~50%. Among other advantages are easier operation and maintenance and smaller footprint.

The desorber system includes a recirculation loop with a high-pressure pump and heat exchanger to provide sufficient heat transfer surface area and increase liquid/gas interfacial area. The ASPEN Plus model flow diagram for the desorber is presented below in Figure 8.

For each of the cases considered below, recirculation loop pump and heat exchanger sizes were calculated and used for capital cost estimation.



**Figure 8.** The desorber section of the ASPEN Plus flow sheet.

The main design parameters for the desorber are temperature, pressure, and residence time. The current optimized desorber operates at a temperature of 130 °C, pressure of 63 psia, and residence time of 11 minutes. The residence time was selected based on a sensitivity analysis which showed that CO<sub>2</sub> desorption approached equilibrium at 11 minutes. The volume of the desorber is calculated based on this residence time.

The values used for the overall heat transfer coefficients for the desorber jacket and recirculation loop heat exchanger were selected based on a literature search and prior calculations, and are presented in Table 7.

**Table 7.** The heat transfer coefficients used in the desorber model.

Type of heat transfer unit	Overall heat transfer coefficient $U$ (Btu/hr·ft <sup>2</sup> ·F)
Jacketed vessels: steam to organics, SS wall, average	100
Shell and Tube heat exchanger: steam to light organics, average	185

The volume of the desorber is calculated based on a residence time of 11 minutes. The amount of heat which can be transferred through the desorber jacket can be calculated based on the following equation:

$$Q_{reactor} = U * A * LMTD$$

The total heat required for the desorber system is calculated by the ASPEN Plus model, and the heat duty for the recirculation loop heat exchanger is also determined. Based on these values, the appropriate size for heat exchanger and number of cycles/minute are calculated. The results for each of the aminosilicone-based cases studied for the carbon capture system are presented below in Table 8.

**Table 8.** Size of desorber and recirculation loop for different carbon capture cases.

	Desorber CSTR		Recirculation loop	
	Total height, ft	Diameter, ft	HEX area, ft <sup>2</sup>	Number of cycles/min
Case A	70	33.0	10,128	0.25
Case B	53	33.0	10,214	0.34
Case C	38	33.0	10,452	0.50
Case D	37	33.0	10,432	0.51
Case E	44	33.0	9,649	0.20
Case H	54	33.0	12,511	0.20

### Rich-Lean Heat Exchanger

In order to recover as much heat as possible from the hot lean solvent stream leaving the desorber, a rich-lean heat exchanger will be utilized to preheat the rich cold solvent leaving the absorber train. In current simulations, the rich-lean heat exchanger is modeled as a shell and tube unit with a constant value of the overall heat transfer coefficient of 75 Btu/hr·ft<sup>2</sup>·F. This value was previously estimated from heat transfer film coefficients based on known physical properties and design assumptions. In the current system, this unit represents ~25% of the total equipment cost for the CO<sub>2</sub>-capture process. Therefore, additional work will be done in the

future to find the optimal design for this heat exchanger, to increase the value of the overall heat transfer coefficient, which will reduce the CAPEX of the CO<sub>2</sub>-capture system.

### Heat Transfer Coefficient

The overall heat transfer coefficient for shell and tube heat exchangers can be calculated from Equation 1.<sup>3</sup>

$$U_o = \frac{1}{\frac{1}{h_o} + R_{do} + \frac{x A_o}{k_w A_{wm}} + \left(\frac{1}{h_i} + R_{di}\right) A_o / A_i} \quad \text{Equation 1}$$

where  $h_o$  and  $h_i$  are individual film heat-transfer coefficients,  $R_{do}$  and  $R_{di}$  are fouling resistances; and  $(xA_o/k_w A_{wm})$  is wall resistance.

Two separate methods were used to calculate individual film heat-transfer coefficients for tube and shell sides.

### Shell-Side Individual Film Heat-Transfer Coefficient

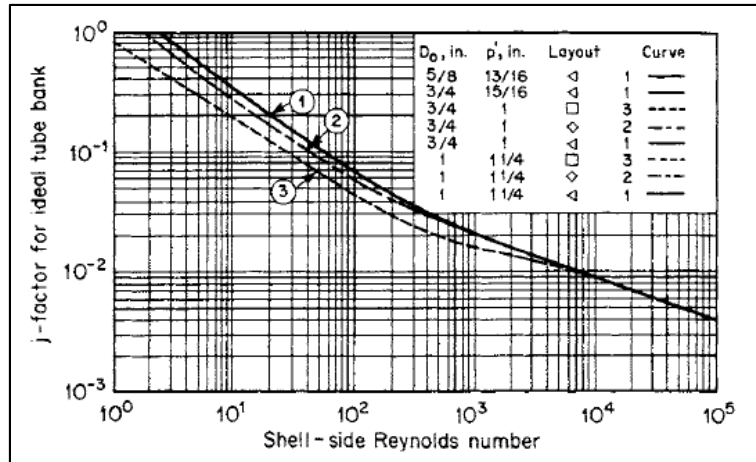
Shell-side heat-transfer coefficient for an ideal tube bank  $h_k$  can be determined from Equation 2.<sup>3</sup>

$$h_k = j_k c \frac{W}{S_m} \left(\frac{k}{c\mu}\right)^{2/3} \left(\frac{\mu_b}{\mu_w}\right)^{0.14} \quad \text{Equation 2}$$

where  $j_k$  is the factor determined from the correlation for j-factor for an ideal tube bank (Figure 9),  $c$  is specific heat,  $k$  is the thermal conductivity,  $\mu_b$  is bulk viscosity of the solvent,  $\mu_w$  is viscosity evaluated at the mean surface temperature,  $W$  is mass flow rate, and  $S_m$  is one cross-flow section.

---

<sup>3</sup> Green, D.; Perry, R. "Perry's Chemical Engineering Handbook, 8<sup>th</sup> edition".



**Figure 9:** Correlation of  $j$  factor for ideal tube bank.<sup>3</sup>

The shell side Reynolds number can be determined from Equation 3.<sup>3</sup>

$$(N_{Re})_s = D_o W / \mu_b S_m \quad \text{Equation 3}$$

Steps for calculation of shell-side heat transfer coefficient are described below.

- 1) Identify assumptions for these calculations:
  - a. Reynolds number on the shell side for MEA and GAP-1m/TEG system is the same, and equals 1,000.
  - b. Ratio of bulk-to-wall viscosity is assumed to be 10. Due to the higher temperature of the wall surface versus bulk, the viscosity will be lower at the surface. The estimated value has little impact on the heat transfer coefficient due to the small exponent in Equation 2. Ten was chosen as a conservative estimate.
  - c. Tube diameter is 1.5 inch.
- 2) Calculate ratio of  $W/S_m$  from Equation 3.
- 3) Find  $j_k$  value from the plot in Figure 9.
- 4) Substitute physical properties of the solvent, value of  $j_k$ , and the value of  $W/S_m$  into the equation 2 to find  $h_o$ .

### Tube-Side Individual Film Heat-Transfer Coefficient

The tube side heat transfer coefficient for circular tubes can be determined from the following Nusselt number correlation for laminar flow.<sup>4</sup>

$$Nu = 1.86(RePr)^{0.33} \left(\frac{d}{L}\right)^{0.33} \left(\frac{\mu_{wall}}{\mu_{bulk}}\right)^{0.14} \quad \text{Equation 4}$$

Also, Nusselt number can be correlated to the heat transfer coefficient  $h$  through the following expression.<sup>5</sup>

$$Nu = \frac{hd}{12k} \quad \text{Equation 5}$$

Below are the steps for the calculation of the tube-side heat transfer coefficient.

- 1) Identify assumption for these calculations:
  - a. Reynolds number on the tube side for MEA and GAP-1m/TEG system is the same, and it equals 1,000 (laminar flow). This number was selected as a moderate value corresponding to a flow of  $\sim 10$  ft/sec.
  - b. Tube diameter is 1.5 in.
- 2) Calculate Prandtl number for each solvent system.
- 3) Calculate Nusselt number from Equation 4.
- 4) Calculate  $h_i$  from Equation 5.

### Overall Heat-Transfer Coefficient

The overall heat transfer coefficient can be calculated from Equation 1, and below are the steps for calculations.

- 1) Identify assumptions for these calculations:
  - a. Thickness of the pipe wall is 0.25 in.
  - b. Pipe material is carbon steel.
  - c. Fouling coefficient is  $5,000 \text{ W/m}^2 \cdot \text{K}$
- 2) Use Equation 1 to determine overall heat transfer coefficient,  $U$ .

These calculations were used to determine the overall heat transfer coefficients for a 30/70 MEA/water system and to compare it to the 60/40 GAP-1m/TEG system. The values of overall

---

<sup>4</sup> Towler, G.; Sinnott, R. "Chemical Engineering Design: Principles, Practice and Economics of Plant and Process Design".

<sup>5</sup> "Simplified Approach to Estimating Tube Side Heat Transfer Coefficients", <http://vganapathy.tripod.com/tubeht.html>.

heat transfer coefficient for 60/40 GAP-1m/TEG and 30/70 MEA/water are 75 and 93 Btu/(hr·ft<sup>2</sup>·F), respectively.

It has to be noted that this value of U is specific to the assumptions made and considered conditions. Due to the high viscosity of the rich GAP-1m/TEG solvent, turbulent flow might be a challenge for the tube side of the heat exchanger, and pressure drop would also need to be considered for the final design. So, a velocity in the laminar regime was chosen. To increase the overall heat transfer, shell-side Reynolds number can be potentially increased.

### Compression Train

The purpose of the compression train is to deliver a high-purity CO<sub>2</sub> stream at 2215 psia for transportation and storage. The discharge pressures at each stage are presented in Table 9.

**Table 9.** The outlet pressures at each stage in the compression train.

Stage	Outlet Pressure, MPa (psia)
1	0.36 (52)
2	0.78 (113)
3	1.71 (248)
4	3.76 (545)
5	8.27 (1,200)
6	15.3 (2,215)

Since the desorber operates at 63 psia in the aminosilicone-based process, the first stage of the compression train can be removed, significantly reducing the cost of the compression train. The pressurized gas stream is cooled to 40 °C after each compressor with cooling water and all liquid condensate is removed in a vapor/liquid flash separator. Cooling water is supplied from the power plant cooling tower system. The compressors at each stage have a polytropic efficiency of 86% and mechanical efficiency of 98%.

The final CO<sub>2</sub> stream has to satisfy the conceptual design limits for enhanced oil recovery as listed in Exhibit 2-1 of the NETL QGESS titled “CO<sub>2</sub> Impurity Design Parameters”.<sup>6</sup> Table 10

---

<sup>6</sup> Quality Guidelines for Energy System Studies, “Cost Estimation Methodology for NETL Assessments of Power Plant Performance”, DOE/NETL-2011/1455.

shows the required specifications for the product CO<sub>2</sub> stream. Table 10 also shows the composition of the CO<sub>2</sub> stream for the aminosilicone base-case model.

**Table 10:** Case H CO<sub>2</sub> stream outlet composition as compared to EOR specifications. Error! Bookmark not defined.

Component	Unit	Enhanced Oil Recovery specification		CASE H
		Conceptual design	Range in Literature	
CO <sub>2</sub>	Vol % (min)	95	90-99.8	99.39
H <sub>2</sub> O	ppm <sub>v</sub>	500	20-650	812
N <sub>2</sub>	Vol%	1	0.01-2	<0.01
O <sub>2</sub>	Vol%	0.001	0.001-1.3	<0.001
Ar	Vol%	1	0.01-1	0

It can be seen that final high pressure CO<sub>2</sub> stream generated by the aminosilicone-based process has slightly higher water amount than the EOR specifications. In future work the amount of cooling will be increased in order to match specification limits.

Multiple cases were considered for technical and economic analysis, and below is the summary table of all cases with specific conditions.

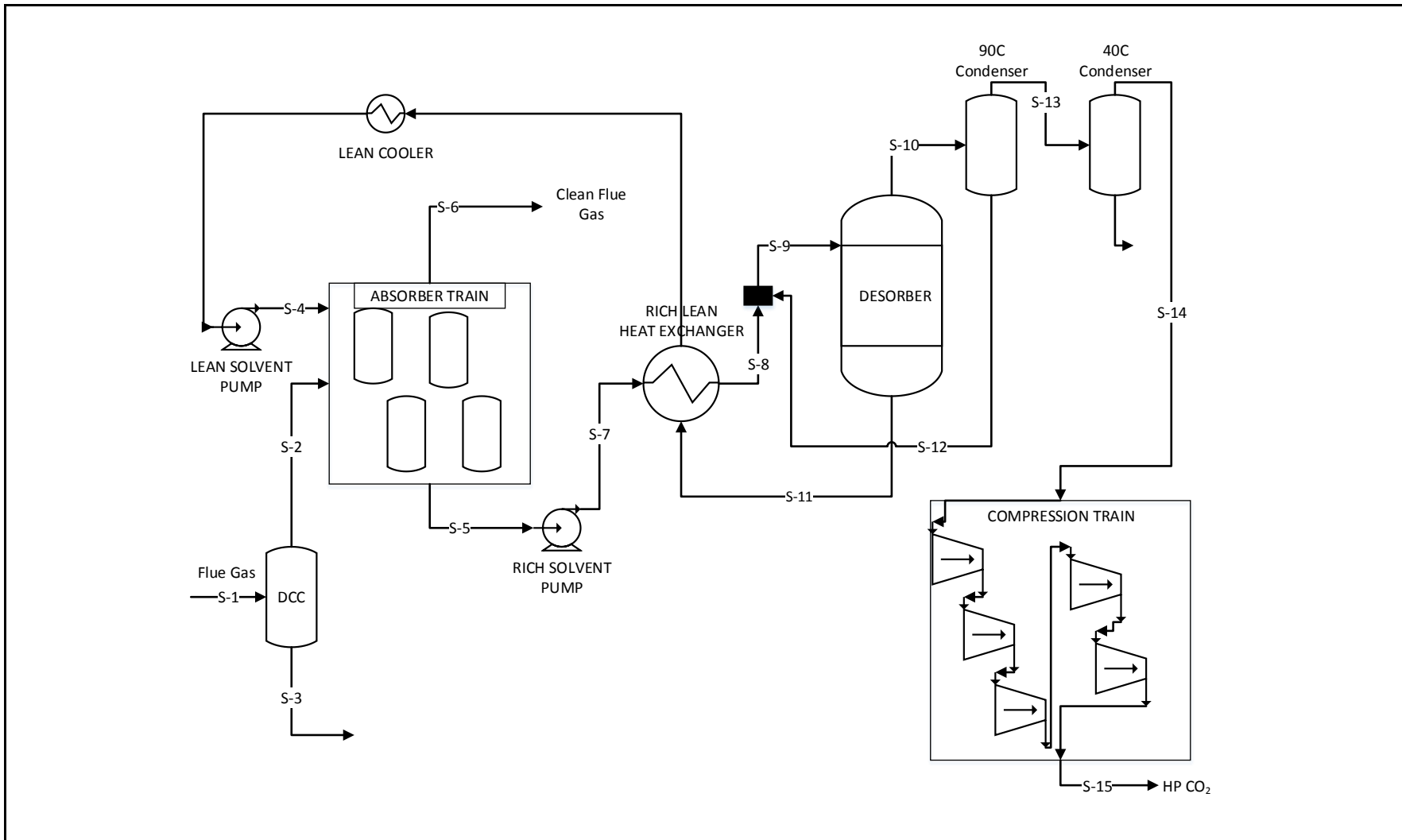


**Table 11:** Summary of major cases considered for the aminosilicone-based CO<sub>2</sub> separation system.

	<i>Absorber intercoolers (Y/N)</i>	<i>Number of absorbers</i>	<i>Intercooler load (each)</i>	<i>Desorber T, °F</i>	<i>Desorber P (psia)</i>	<i>Number of desorbers</i>	<i>Absorber packing type</i>	<i>Packing material</i>	<i>Sulfur in FG (ppm)</i>
Case A	N	4	NA	284 °F	63	2	Rachig rings	CS	5
Case B	Y	4	30 MW	284 °F	63	2	Rachig rings	CS	5
Case C	Y	4	60 MW	284 °F	63	2	Rachig rings	CS	5
Case D	Y	4	60 MW	284 °F	63	2	MellapakPL 252Y	CS	5
Case E	Y	4	60 MW	266 °F	63	2	MellapakPL 252Y	CS	5
Case F	Y	3	80 MW	266 °F	63	2	MellapakPL 252Y	CS	5
Case G	Y	3	80 MW	266 °F	63	2	MellapakPL 252Y	CS	5

Case G was scaled up to 552 MW net power including the CO<sub>2</sub>-capture island to generate Case H.

The CO<sub>2</sub>-capture system block flow diagram scaled-up to 552 MW net power for Case H is presented on Figure 10 and the corresponding stream table is presented in Table 12.



**Figure 4.** Block flow diagram of CO<sub>2</sub>-capture system for Case H.

**Table 12.** Stream table for CO<sub>2</sub>-capture system for Case H.

Stream Number	S-1	S-2	S-3	S-4	S-5	S-6	S-7	S-8
Mole Fraction								
H <sub>2</sub> O	0.1517	0.0731	0.9999	0.2420	0.2820	0.0436	0.2820	0.2820
CO <sub>2</sub>	0.1353	0.1478	0.0001	0.0090	0.0007	0.0192	0.0007	0.0007
N <sub>2</sub>	0.6890	0.7528	0.0000	0.0001	0.0010	0.9057	0.0010	0.0010
O <sub>2</sub>	0.0240	0.0262	0.0000	0.0000	0.0000	0.0316	0.0000	0.0000
GAP1	0.0000	0.0000	0.0000	0.2190	0.0215	0.0000	0.0215	0.0215
GAP1CARB	0.0000	0.0000	0.0000	0.0789	0.2631	0.0000	0.2631	0.2631
TEG	0.0000	0.0000	0.0000	0.4510	0.4317	0.0000	0.4317	0.4317
Total	1.0000	1.0000	1.0000	1.0000	1.0000	1.0000	1.0000	1.0000
Total Flow lbmol/hr	212,156	194,164	17,992	136,228	142,321	161,256	142,321	142,321
Total Flow lb/hr	6,100,920	5,776,755	324,165	23,414,975	24,648,212	4,516,809	24,648,212	24,648,212
Temperature F	135	104	104	104	122	128	123	240
Pressure psia	14.7	14.7	14.7	15	14.7	14.7	93	93
Vapor Frac	1	1	0	0	0	1	0	0
Enthalpy Btu/lb	-1329.5	-1089.4	-6791.9	-2272.7	-2407.9	-264.7	-2407.7	-2350.2
Density lb/cuft	0.066	0.072	61.142	56.338	58.046	0.065	58.025	53.743
Average MW	28.757	29.752	18.017	171.881	173.187	28.010	173.187	173.187

Stream Number	S-9	S-10	S-11	S-12	S-13	S-14	S-15
Mole Fraction							
H <sub>2</sub> O	0.2853	0.1629	0.2574	0.8924	0.1444	0.0170	0.0008
CO <sub>2</sub>	0.0007	0.8299	0.0085	0.0020	0.8509	0.9778	0.9939
N <sub>2</sub>	0.0010	0.0044	0.0000	0.0000	0.0045	0.0052	0.0053
O <sub>2</sub>	0.0000	0.0000	0.0000	0.0000	0.0000	0.0000	0.0000
GAP1	0.0218	0.0018	0.2159	0.0689	0.0001	0.0000	0.0000
GAP1CARB	0.2618	0.0006	0.0757	0.0244	0.0000	0.0000	0.0000
TEG	0.4294	0.0003	0.4424	0.0122	0.0000	0.0000	0.0000
Total	1.0000	1.0000	1.0000	1.0000	1.0000	1.0000	1.0000
Total Flow lbmol/hr	143,095	31,144	138,883	774	30,370	26,423	25,991
Total Flow lb/hr	24,686,221	1,259,768	23,426,717	38,009	1,221,759	1,148,988	1,141,107
Temperature F	240	266	266	194	194	104	124
Pressure psia	63	63	63	63	63	63	2215
Vapor Frac	0	1	0	0	1	1	1
Enthalpy Btu/lb	-2352.1	-3887.1	-2202.7	-3549.3	-3927.6	-3839.2	-3822.1
Density lb/cuft	53.705	0.327	50.617	43.516	0.361	0.453	15.526
Average MW	172.517	40.450	168.680	49.124	40.229	43.484	43.904

## System Utilities for CO<sub>2</sub> Capture Process

The CO<sub>2</sub> capture process adds additional auxiliary load on coal power plants, and the main contributors are solvent pumps, CO<sub>2</sub> compressors, flue gas blowers, cooling water fans and pumps. Table 13 shows the power summary for Case H of the CO<sub>2</sub>-capture system. It should be noted that the main feed-gas blower is part of the power plant, and only the additional power to increase the flue gas pressure to the required inlet pressure of the CO<sub>2</sub>-capture process is shown in Table 13. The cooling tower is also part of the power plant, and its operation and capital costs are included in the power plant island costs. Therefore, the table shows only the power for the cooling water pumps, which deliver water from the cooling tower to the CO<sub>2</sub>-capture process. CO<sub>2</sub> separation auxiliaries include lean and rich solvent pumps.

**Table 13:** Power summary for Case H.

POWER SUMMARY	
AUXILIARY LOAD SUMMARY, kWe	
Feed Gas Blower	911
CO <sub>2</sub> Separation Auxiliaries	2,098
CO <sub>2</sub> Compression	43,088
Cooling Water Pumps	6,866
TOTAL AUXILIARIES, kWe	52,963
COOLING WATER, ton/hr	45,600
STEAM, ton/hr	750

## CO<sub>2</sub> Separation Unit Key Assumptions

The CO<sub>2</sub>-separation process model used the following design assumptions given in Case 11 of DOE NETL Bituminous Baseline Study.<sup>1</sup>

- 1) Composition of flue gas leaving the FGD (wet basis) is shown in Table 14.

**Table 14.** Flue gas composition leaving FGD.

	Volume %
CO <sub>2</sub>	13.53
H <sub>2</sub> O	15.17
N <sub>2</sub>	68.9
O <sub>2</sub>	2.40
	ppmv
SO <sub>x</sub>	5-42
NO <sub>x</sub>	74

2) The flow rate of flue gas leaving the FGD (based on DOE Case 11 550 MW net supercritical PC plant): 4,713,221 lb/hr. The flow rate for the scaled-up cases varied due to differences in overall plant efficiency with the various CO<sub>2</sub>-capture system configurations.

3) Pressure and temperature of flue gas leaving FGD: 14.8 psia and 135 °F

4) Conditions for LP steam available from power plant: 556 °F (base case, sensitivity was conducted with respect to steam conditions)

5) Conditions for cooling water: feed = 60 °F, return = 80 °F with a minimum approach of 30 °F (sensitivity was conducted with respect to cooling water conditions)

6) CO<sub>2</sub> removal from flue gas: greater than 90%

7) CO<sub>2</sub> purity: greater than 95 vol%

8) CO<sub>2</sub> delivery pressure and temperature: 2,215 psia and 124 °F

The MEA and aminosilicone-based solvent baseline models are based on a typical temperature-swing sorbent separation process. The systems have four process variables that dominate the performance with a given sorbent and they are absorber temperature, desorber temperature, desorber pressure, and rich-lean heat exchanger approach temperature. The system models account for the major energy penalties for CO<sub>2</sub> separation, and they include the energy required:

(1) for vaporization of water

(2) to desorb the carbon dioxide (i.e., reaction energy)

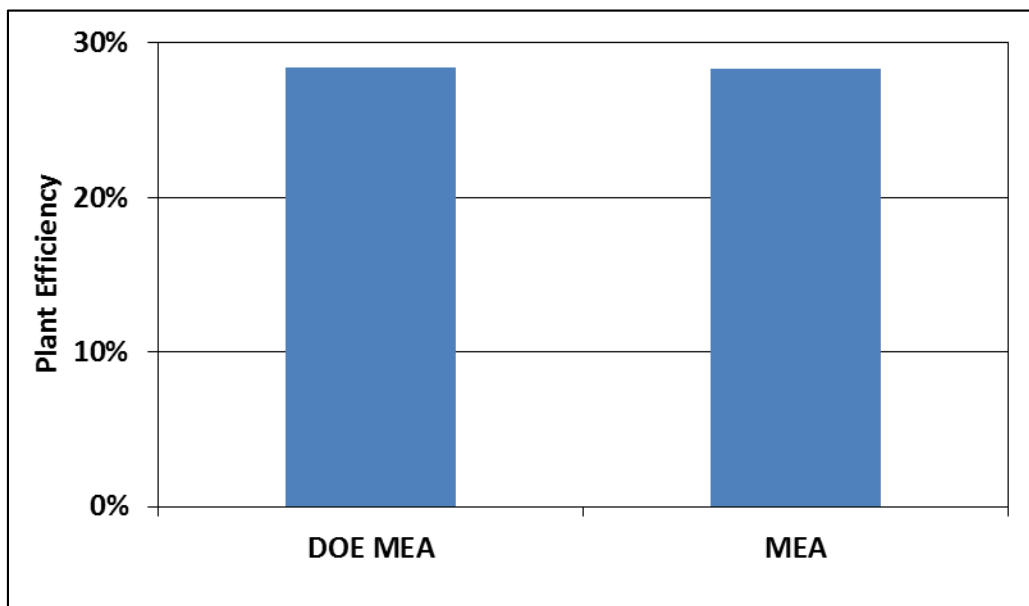
(3) for sensible heating of the sorbent

The energy is supplied by feeding steam to the desorber unit. The models also account for CO<sub>2</sub>-compression energy and auxiliary loads.

The sorbent-rich loading is defined as the weight % of CO<sub>2</sub> in the rich sorbent leaving the absorber column. The sorbent lean loading is defined as the weight % of CO<sub>2</sub> in the lean sorbent leaving the desorber column. The sorbent net loading is defined as the difference between the rich loading and the lean loading and was obtained from bench-scale experiments for the GAP-1m/TEG system.

A detailed MEA Aspen Plus™ model that was built under this project was used to compare the results for this study.

The main features of the MEA model include an absorber, rich-lean heat exchanger, and a desorber. The same unit operations are important for the GAP-1m/TEG system. The baseline MEA case is built from the description given in the Bituminous Baseline Study.<sup>1</sup> Figure 11 shows a comparison of the plant efficiency reported for Case 12 in the Bituminous Baseline Study with the plant efficiency calculated using GE Global Research's models for MEA and the power plant.



**Figure 11.** Comparison of estimated plant efficiency of CO<sub>2</sub> capture system using MEA vs. DOE estimated efficiency.

## Studies of Integrated Power Plant with CO<sub>2</sub>-Capture Plant

A number of different process options were studied for the aminosilicone-based CO<sub>2</sub> capture system. Table 15 lists the modifications that were made from Case A to Case J.

**Table 15.** List of major cases for CO<sub>2</sub> capture system using aminosilicones.

MEA	Base MEA (DOE Case 11 w CC and, Case 12)
<b>Aminosilicone Cases</b>	
Case A	284 °F, 63 psia
Case B	Added Absorber Intercoolers
Case C	Increased Intercooling
Case D	Structured Packing
Case E	Reduced Desorber Temperature
Case F	Reduced Number of Absorbers
Case G	Reduced Absorber Diameter
<b>Scaled Up Aminosilicone Cases</b>	
Case H	Scaled to 550 MW Net
Case I	Cooling Water Integration
Case J	Waste Heat Recovery

The Figure 12 shows the plant efficiency for the different cases as compared to Case 12 in the DOE NETL Bituminous Baseline Study.<sup>1</sup> The plant efficiency for Case G is 30.1% as compared to 28.4% for the case using MEA. After scaling up the power island and the carbon-capture island to 550 MW net power, two more cases were evaluated that utilized heat integration between the two islands. The efficiency of the best case was improved to 30.4% by utilizing the heat integration strategies. The Figure 13 shows the energy penalty for each case.



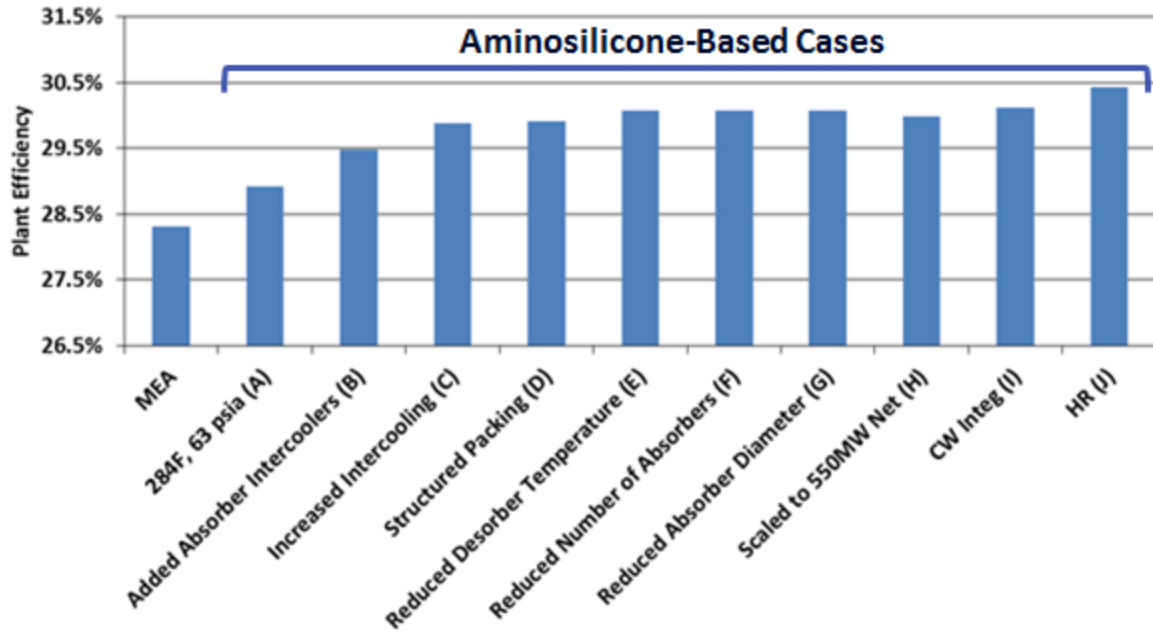


Figure 5. Plant efficiency of for each case.

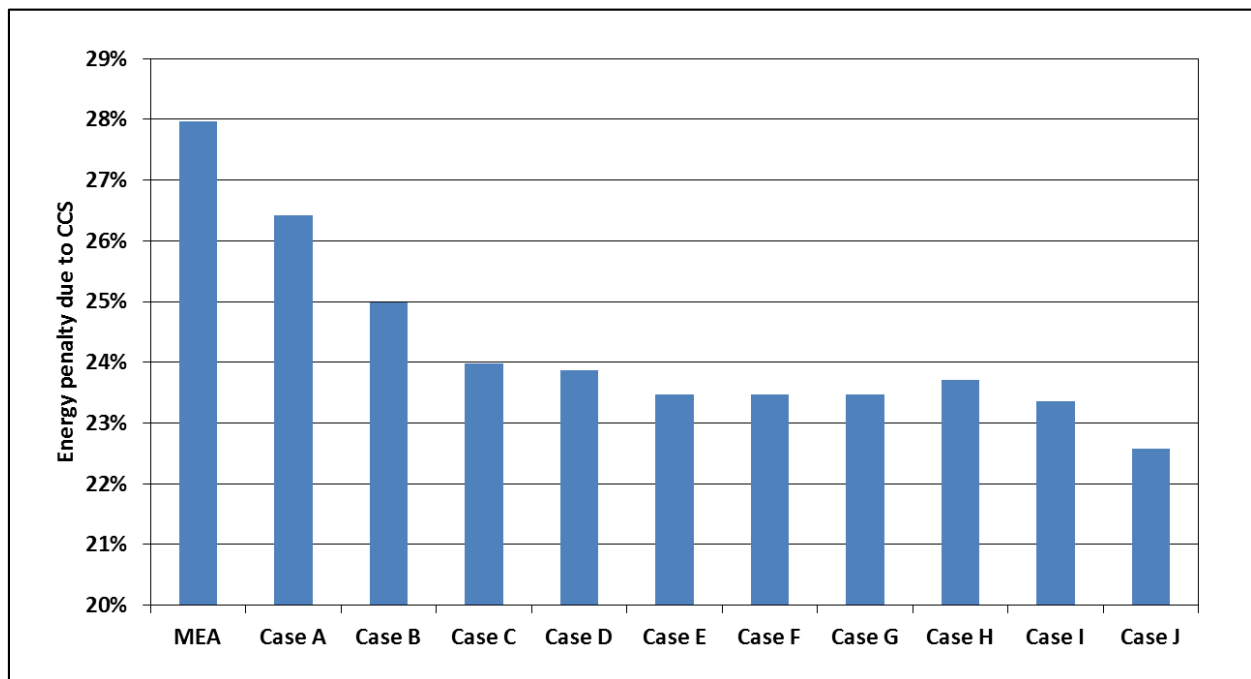


Figure 6. Energy penalty due to CO<sub>2</sub>-capture system for each case.

## Steam Reboiler Factor

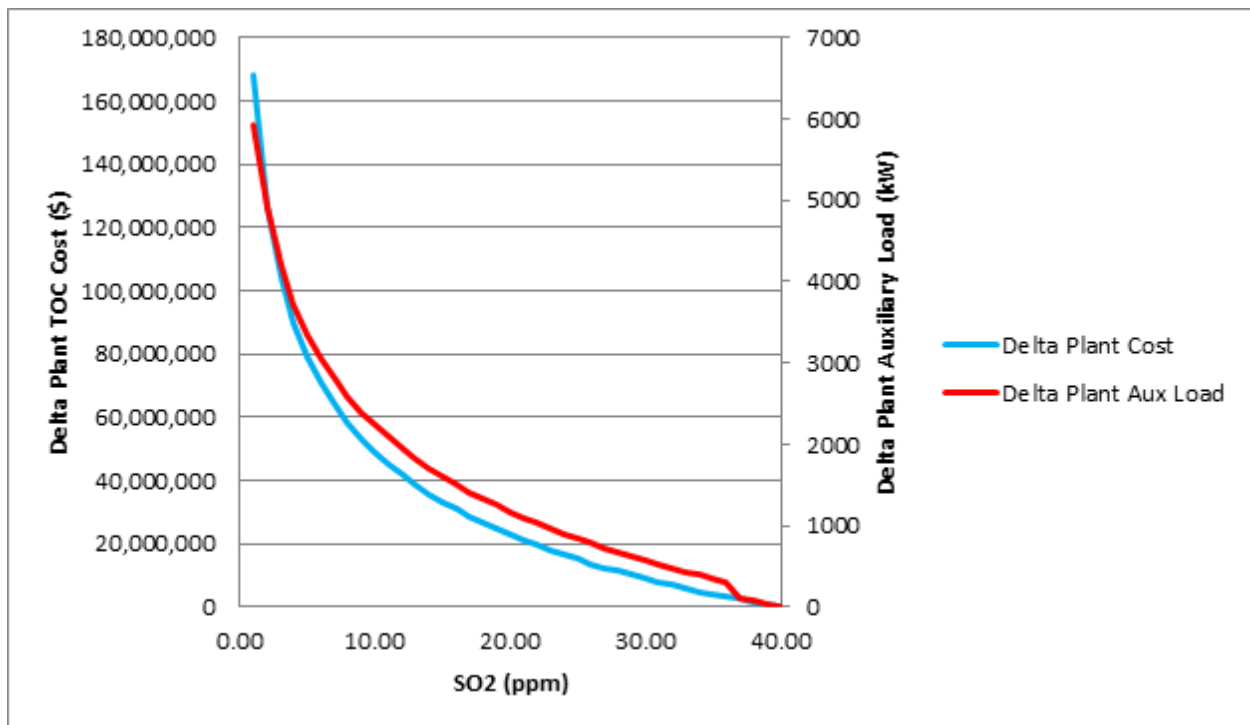
One of the most important factors that determines the energy penalty using carbon capture is the steam penalty. A steam penalty factor in kWh/lb can be calculated based on the steam condition that is used in the carbon capture island. The energy penalty of carbon capture on a power plant is highly dependent on this factor and hence the steam extraction conditions. This factor was calculated by power plant modeling in Thermoflow and was estimated at 0.076 kWh/lb and 0.074 kWh/lb if steam is extracted at 571.4 °F/75 psia and 530.9 °F/60 psia for desorber operating temperatures of 284 °F and 266 °F, respectively. The effect of this factor can be seen in the plant efficiency in Figure 12 between Case D and Case E.

After the power plant model was calibrated to Case 11, it was altered to allow for integration with the carbon capture process. One of the larger interactions between the power block and the carbon capture models is the export of process steam for use in the capture plant's desorber. Extracting such a large amount of steam has a significant impact on the design of the power cycle. In the model calibrated to Case 11, the low-pressure (LP) steam flow was sufficient to require a 4-flow low-pressure steam turbine. In the case with carbon capture almost half of the LP steam flow is diverted to the carbon-capture plant and thus only a 2-flow LP steam turbine is required. The selection of a 2-flow LP steam turbine over a 4-flow makes a large difference to steam turbine cost (~\$60MM). Additionally, the selection of the crossover pressure is heavily influenced by the CO<sub>2</sub>-capture process steam extraction. The desorber in the carbon-capture plant is designed to extract the maximum amount of heat from the process steam by condensing it to a saturated liquid. This sets a minimum steam pressure that can be utilized. If steam were extracted at too low of a pressure, it would not condense at the operating temperatures of the desorber, and a significantly larger extraction of steam would be required. Extracting steam above the minimum pressure doesn't yield significant cost savings, and is worse from a performance perspective, so the operating temperature of the desorber directly sets the optimum crossover pressure in the power block. Because of this, the desorber operating temperature was reduced from 284 °F to 266 °F (Case D to Case E) in order to allow an extraction of steam at a lower pressure, for an improvement in cycle efficiency. In this design, the steam side of the desorber operates at 54 psia, so the crossover pressure was selected to be 60 psia.

The condensate water returning from the desorber is still warm, but is only available at a low pressure. Returning the condensate to the condenser would be a waste of valuable heat, and would drive up the cooling tower duty. Alternatively, the condensate could be used for feedwater heating, either by passing it through the hot side of one or more feedwater heaters before returning it to the condenser, or by pumping the condensate to a high enough pressure to be admitted to the de-aerating feedwater heater. In this model it was selected to return the

condensate to the de-aerating feedwater heater, but further optimization of this aspect of the design may be possible.

It is also important to consider an optimization of equipment affecting the flow of flue gases to the CO<sub>2</sub>-capture equipment. Sulfur content in the exhaust gases has a detrimental effect on CO<sub>2</sub>-capture hardware and solvents, so additional flue gas desulfurization equipment in the power block can be justified based on a reduction in maintenance and material costs for the CO<sub>2</sub>-capture plant. Increasing the effectiveness of the flue gas desulfurization system comes at a cost of both increased capital costs and increased auxiliary loads. In the design of this plant the flue gas sulfur content was optimized in order to minimize the cost of CO<sub>2</sub>-capture. Initially the flue gas desulfurization system was designed to leave 42 ppm of SO<sub>2</sub> in the flue gas. In order to decrease the amount of SO<sub>2</sub>, the cost of flue gas desulfurization equipment increases significantly. The optimal point for minimized CO<sub>2</sub> capture cost was found at 5 ppm of sulfur. Figure 14 shows the cost and auxiliary load deltas that were found during the optimization of the flue gas desulfurization system.



**Figure 14.** Flue gas desulfurization optimization.

Detailed process flow information for each stream in Case H (Case G scaled to 550 MW net) is provided in Table 16. The stream numbers in Table 16 are in reference to the simplified block diagram in Figure 3, and are consistent with the numbering scheme shown for the case without CO<sub>2</sub> capture.

**Table 16.** Stream properties from power plant modeling of Case H. The stream numbers correspond to the block flow diagram shown in Figure 3.

	1	2	3	4	5	6	7
V-L Mole Fraction							
Ar	0.0093	0.0093	0.0093	0.0093	0.0000	0.0000	0.0088
CO <sub>2</sub>	0.0003	0.0003	0.0003	0.0003	0.0000	0.0000	0.1485
H <sub>2</sub>	0.0000	0.0000	0.0000	0.0000	0.0000	0.0000	0.0000
H <sub>2</sub> O	0.0101	0.0101	0.0101	0.0101	0.0000	0.0000	0.0893
N <sub>2</sub>	0.7729	0.7729	0.7729	0.7729	0.0000	0.0000	0.7310
O <sub>2</sub>	0.2074	0.2074	0.2074	0.2074	0.0000	0.0000	0.0202
SO <sub>2</sub>	0.0000	0.0000	0.0000	0.0000	0.0000	0.0000	0.0022
Total	1.0000	1.0000	1.0000	1.0000	0.0000	0.0000	1.0000
V-L Flowrate (lbmol/hr)	139,244	139,244	42,774	42,774	-	-	192,772
V-L Flowrate (lb/hr)	4,017,852	4,017,852	1,234,242	1,234,242	-	-	5,737,068
Solids Flowrate (lb/hr)	-	-	-	-	538,439	10,686	42,744
Temperature (°F)	59	65	59	77	59	-	342
Pressure (psia)	14.7	15.1	14.7	16.2	14.7	-	14.3
Enthalpy (Btu/lbm)	-4.3	-3.0	-4.3	0.1	-	-	69.2
Density (lb/ft <sup>3</sup> )	0.076	0.078	0.076	0.081	-	-	0.047
V-L Molecular Weight	28.85	28.85	28.85	28.85	-	-	29.76

	8	9	10	11	12	13	14
V-L Mole Fraction							
Ar	0.0000	0.0088	0.0088	0.0000	0.0093	0.0000	0.0000
CO <sub>2</sub>	0.0000	0.1485	0.1485	0.0000	0.0003	0.0000	0.0004
H <sub>2</sub>	0.0000	0.0000	0.0000	0.0000	0.0000	0.0000	0.0000
H <sub>2</sub> O	0.0000	0.0893	0.0893	1.0000	0.0101	1.0000	0.9996
N <sub>2</sub>	0.0000	0.7310	0.7310	0.0000	0.7729	0.0000	0.0000
O <sub>2</sub>	0.0000	0.0202	0.0202	0.0000	0.2074	0.0000	0.0000
SO <sub>2</sub>	0.0000	0.0022	0.0022	0.0000	0.0000	0.0000	0.0000
Total	0.0000	1.0000	1.0000	1.0000	1.0000	1.0000	1.0000
V-L Flowrate (lbmol/hr)	-	192,772	192,772	20,917	3,052	11,339	467
V-L Flowrate (lb/hr)	-	5,737,068	5,737,068	376,920	88,056	204,322	8,424
Solids Flowrate (lb/hr)	42,744	-	-	-	-	45,194	75,672
Temperature (°F)	-	342	362.9	59	59	59	0
Pressure (psia)	-	13.84	15.06	14.7	14.7	14.7	0.0
Enthalpy (Btu/lbm)	-	69.2	74.7	27.1	-4.3	-	-
Density (lb/ft <sup>3</sup> )	-	0.046	0.048	62.379	0.076	-	-
V-L Molecular Weight	-	29.76	29.76	18.02	28.85	-	18.03

	15	16	17	18	19	20	21
V-L Mole Fraction							
Ar	0.0081	0.0000	0.0000	0.0000	0.0000	0.0000	0.0000
CO <sub>2</sub>	0.1372	0.0000	0.0000	0.0000	0.0000	0.0000	0.0000
H <sub>2</sub>	0.0000	0.0000	0.0000	0.0000	0.0000	0.0000	0.0000
H <sub>2</sub> O	0.1577	1.0000	1.0000	1.0000	1.0000	1.0000	1.0000
N <sub>2</sub>	0.6766	0.0000	0.0000	0.0000	0.0000	0.0000	0.0000
O <sub>2</sub>	0.0204	0.0000	0.0000	0.0000	0.0000	0.0000	0.0000
SO <sub>2</sub>	0.0000	0.0000	0.0000	0.0000	0.0000	0.0000	0.0000
Total	1.0000	1.0000	1.0000	1.0000	1.0000	1.0000	1.0000
V-L Flowrate (lbmol/hr)	211,766	266,843	221,783	221,783	197,442	83,241	197,442
V-L Flowrate (lb/hr)	6,100,922	4,808,520	3,996,538	3,996,538	3,557,905	1,500,000	413,566
Solids Flowrate (lb/hr)	-	-	-	-		-	-
Temperature (°F)	132	1100	663	1100	531	528	531
Pressure (psia)	14.7	3514.7	693.7	655.8	60.0	54.1	60.0
Enthalpy (Btu/lbm)	14.9	1495.0	1323.2	1570.5	1298.3	1297.3	1298.3
Density (lb/ft <sup>3</sup> )	0.063	4.319	1.143	0.722	0.103	0.093	0.103
V-L Molecular Weight	28.81	18.02	18.02	18.02	18.02	18.02	18.02

	22	23	24	25
V-L Mole Fraction				
Ar	0.0000	0.0000	0.0000	0.0000
CO <sub>2</sub>	0.0000	0.0000	0.0000	0.0000
H <sub>2</sub>	0.0000	0.0000	0.0000	0.0000
H <sub>2</sub> O	1.0000	1.0000	1.0000	1.0000
N <sub>2</sub>	0.0000	0.0000	0.0000	0.0000
O <sub>2</sub>	0.0000	0.0000	0.0000	0.0000
SO <sub>2</sub>	0.0000	0.0000	0.0000	0.0000
Total	1.0000	1.0000	1.0000	1.0000
V-L Flowrate (lbmol/hr)	75,343	115,437	83,241	197,442
V-L Flowrate (lb/hr)	1,357,682	2,080,170	1,500,000	4,808,520
Solids Flowrate (lb/hr)	-	-	-	-
Temperature (°F)	101	107	286	557
Pressure (psia)	1.0	258.5	133.6	4185.2
Enthalpy (Btu/lbm)	1023.5	75.2	255.5	552.9
Density (lb/ft <sup>3</sup> )	0.003	61.959	57.758	47.687
V-L Molecular Weight	18.02	18.02	18.02	18.02



Table 17 summarizes power output from the power plant along with materials consumed during normal operation for Case H. It includes a detailed summary of auxiliary loads and how they contribute with the steam turbine power and CO<sub>2</sub> capture and compression loads to impact the total plant net power output and efficiency.

**Table 17.** Power summary from power plant modeling of Case H.

<b>POWER SUMMARY (Gross Power at Generator Terminals, kWe)</b>	
Steam Turbine Power	647,695
<b>Total (Steam Turbine) Power, kWe</b>	<b>647,695</b>
<b>Auxiliary Load Summary, kWe</b>	
Boiler Fuel Delivery	4,221
Ash handling	694
Primary Air Fans	1,783
Forced Draft Fans	2,000
Induced Draft Fans	9,746
Baghouse (ESP)	91
Wet FGD	11,857
CO <sub>2</sub> Island Auxiliaries	9,875
CO <sub>2</sub> Compression	43,088
Miscellaneous BOP	118
ST Auxiliaries	446
Condensate Pumps	699
Circulating Water Pumps	3,142
Cooling Tower Fans	5,262
Transformer Losses	2,031
BFP Booster Pump	652
<b>Total Auxiliaries, kWe</b>	<b>42,743</b>
<b>Net Power, kWe</b>	<b>551,989</b>
Net Plant Efficiency (HHV)	30.0%
Net Plant Heat Rate, (Btu/kWh)	10,383
<b>Condenser Cooling duty, (10<sup>6</sup> Btu/hr)</b>	<b>3,544</b>
<b>Consumables</b>	
As-Received Coal Feed, (lb/hr)	538,439
Limestone Sorbent Feed, (lb/hr)	45,180
Thermal Input (kWt)	1,840,906
Raw Water Consumption (gpm)	6,740

The net power for Case H is calculated to be ~552MW.

The cost summary for the power plant model with CO<sub>2</sub> capture (Case H) is shown in Table 18. The total cost of the power block increased by ~\$333MM over the case without CO<sub>2</sub> capture.

**Table 18.** Equipment cost summary from power plant modeling of Case H.

	\$	\$/kW
<b>Specialized Equipment</b>	<b>\$ 609,811,487</b>	<b>\$ 1,105</b>
<b>Boiler</b>	<b>\$ 234,107,909</b>	<b>\$ 424</b>
Furnace	\$ 101,283,882	\$ 183
Convective Elements	\$ 65,610,249	\$ 119
Additional Waterwall	\$ 7,507,987	\$ 14
Soot Blowers	\$ 6,098,788	\$ 11
Desuperheaters and Controls	\$ 10,253,053	\$ 19
Air and Flue Gas Ducts	\$ 7,467,654	\$ 14
Coal Pulverizers and Feeders	\$ 24,580,927	\$ 45
FD Fan, PA Fan, ID Fan	\$ 3,878,047	\$ 7.0
Structural Steel, Ladders, Walkways	\$ 3,064,060	\$ 5.6
Rotary Air Heaters	\$ 4,363,261	\$ 7.9
<b>Steam Turbine</b>	<b>\$ 89,908,464</b>	<b>\$ 163</b>
<b>Feedwater Heaters</b>	<b>\$ 11,359,687</b>	<b>\$ 21</b>
Feedwater Heater 1	\$ 542,457	\$ 1.0
Feedwater Heater 2	\$ 527,972	\$ 1.0
Feedwater Heater 3	\$ 527,728	\$ 1.0
Feedwater Heater 4	\$ 537,078	\$ 1.0
Feedwater Heater 5-DA	\$ 895,946	\$ 1.6
Feedwater Heater 6 (6A,6B)	\$ 2,390,574	\$ 4.3
Feedwater Heater 7 (7A,7B)	\$ 2,764,842	\$ 5.0
Feedwater Heater 8 (8A,8B)	\$ 3,173,090	\$ 5.7
<b>Water Cooled Condensers</b>	<b>\$ 3,201,005</b>	<b>\$ 5.8</b>
Main Condenser	\$ 2,467,013	\$ 4.5
Feed Pump Turbine Condenser	\$ 733,991	\$ 1.3
<b>Particulate and Mercury Control</b>	<b>\$ 26,720,630</b>	<b>\$ 48</b>
<b>Flue Gas Desulfurization</b>	<b>\$ 151,257,175</b>	<b>\$ 274</b>

<b>Nitrogen Oxide Control (SCR)</b>	<b>\$ 52,211,298</b>	<b>\$ 95</b>
<b>Stack</b>	<b>\$ 10,733,066</b>	<b>\$ 19</b>
<b>Continuous Emissions Monitoring System</b>	<b>\$ 627,300</b>	<b>\$ 1.1</b>
<b>Distributed Control System</b>	<b>\$ 1,737,273</b>	<b>\$ 3.1</b>
<b>Transmission Voltage Equipment</b>	<b>\$ 16,574,415</b>	<b>\$ 30</b>
Transformers	\$ 14,739,549	\$ 27
Circuit Breakers	\$ 1,045,579	\$ 1.9
Miscellaneous Equipment	\$ 789,287	\$ 1.4
<b>Generating Voltage Equipment</b>	<b>\$ 11,373,267</b>	<b>\$ 21</b>
Generator Buswork	\$ 5,935,887	\$ 11
Circuit Breakers	\$ 4,895,854	\$ 8.9
Miscellaneous Equipment	\$ 541,526	\$ 1.0

<b>Other Equipment</b>	<b>\$ 154,572,349</b>	<b>\$ 280</b>
<b>Pumps</b>	<b>\$ 15,195,073</b>	<b>\$ 28</b>
Boiler Feed Pump (+ Turbine)	\$ 11,234,334	\$ 20
Boiler Feed Booster Pump	\$ 173,367	\$ 0.3
Condenser C.W. Pump	\$ 1,858,945	\$ 3.4
Condensate Forwarding Pump	\$ 377,533	\$ 0.7
Condenser Vacuum Pump	\$ 398,799	\$ 0.7
Aux Cooling Water Pump (Closed Loop)	\$ 43,656	\$ 0.1
Treated Water Pump	\$ 7,199	\$ 0.01
Diesel Fire Pump	\$ 172,817	\$ 0.3
Jockey Fire Pump	\$ 5,182	\$ 0.01
Demin Water Pump	\$ 14,251	\$ 0.03
Raw Water Pumps	\$ 34,857	\$ 0.1
Aux Cooling Water Pump (Open Loop)	\$ 43,656	\$ 0.1
Startup Boiler Feed Pump	\$ 830,475	\$ 1.5
<b>Tanks</b>	<b>\$ 1,052,452</b>	<b>\$ 1.9</b>
Hydrous Ammonia	\$ 168,509	\$ 0.3
Demin Water	\$ 116,820	\$ 0.2
Raw Water	\$ 395,305	\$ 0.7
Neutralized Water	\$ 86,820	\$ 0.2
Acid Storage	\$ 36,341	\$ 0.1

Caustic Storage	\$ 36,341	\$ 0.1
Dedicated Fire Protection Water Storage	\$ 212,316	\$ 0.4
<b>Cooling Tower</b>	<b>\$ 15,094,192</b>	<b>\$ 27</b>
<b>Auxiliary Cooling Water Heat Exchanger</b>	<b>\$ 152,969</b>	<b>\$ 0.3</b>
<b>Steam Turbine Crane</b>	<b>\$ 1,403,592</b>	<b>\$ 2.5</b>
<b>Station Instrument Air Compressors</b>	<b>\$ 955,936</b>	<b>\$ 1.7</b>
<b>General Plant Instrumentation</b>	<b>\$ 446,686</b>	<b>\$ 0.8</b>
<b>Medium Voltage Equipment</b>	<b>\$ 8,499,153</b>	<b>\$ 15</b>
Transformers	\$ 1,225,828	\$ 2.2
Circuit Breakers	\$ 501,147	\$ 0.9
Switchgear	\$ 2,149,781	\$ 3.9
Motor Control Centers	\$ 4,217,678	\$ 7.6
Miscellaneous	\$ 404,719	\$ 0.7
<b>Low Voltage Equipment</b>	<b>\$ 2,328,973</b>	<b>\$ 4.2</b>
Transformers	\$ 822,781	\$ 1.5
Circuit Breakers	\$ 670,152	\$ 1.2
Motor Control Centers	\$ 725,143	\$ 1.3
Miscellaneous	\$ 110,898	\$ 0.2
<b>Coal Handling Equipment</b>	<b>\$ 77,179,135</b>	<b>\$ 140</b>
<b>Ash Handling Equipment</b>	<b>\$ 24,903,817</b>	<b>\$ 45</b>
<b>Miscellaneous Equipment</b>	<b>\$ 7,360,371</b>	<b>\$ 13</b>

<b>Civil</b>	<b>\$ 105,551,677</b>	<b>\$ 191</b>
<b>Site Work</b>	<b>\$ 19,774,449</b>	<b>\$ 36</b>
<b>Excavation and Backfill</b>	<b>\$ 6,839,480</b>	<b>\$ 12</b>
<b>Concrete</b>	<b>\$ 77,768,896</b>	<b>\$ 141</b>
<b>Roads Parking and Walkways</b>	<b>\$ 1,168,852</b>	<b>\$ 2.1</b>

<b>Mechanical</b>	<b>\$ 332,077,085</b>	<b>\$ 602</b>
-------------------	-----------------------	---------------

<b>On Site Transportation and Rigging</b>	\$ 11,121,067	\$ 20
<b>Equipment Erection and Assembly</b>	\$ 239,556,407	\$ 434
<b>Piping</b>	\$ 78,972,668	\$ 143
<b>Steel</b>	\$ 2,426,944	\$ 4.4

<b>Electrical Assembly and Wiring</b>	\$ 30,318,365	\$ 55
<b>Controls</b>	\$ 18,598,808	\$ 34
<b>Assembly and Wiring</b>	\$ 11,719,557	\$ 21

<b>Buildings and Structures</b>	\$ 22,448,094	\$ 41
<b>Boiler House and Turbine Hall</b>	\$ 20,400,100	\$ 37
<b>Administration Control Room, Machine Shop, Warehouse</b>	\$ 2,021,483	\$ 3.7
<b>Guard House</b>	\$ 26,510	\$ 0.05

<b>Engineering and Plant Startup</b>	\$ 56,170,844	\$ 102
<b>Engineering</b>	\$ 45,503,738	\$ 82
<b>Start Up</b>	\$ 10,667,106	\$ 19

<b>Totals</b>		
<b>Subtotal Contractor's Internal Cost</b>	\$ 1,310,949,901	\$ 2,375
Contractors Soft & Misc Costs	\$ 253,644,708	\$ 460
<b>Subtotal Contractor's Price</b>	\$ 1,564,594,609	\$ 2,834
Owner's Soft and Misc Costs	\$ 293,990,948	\$ 533
<b>Total Owner's Cost</b>	\$ 1,858,585,556	\$ 3,367

Table 19 shows the calculated annual costs for the power block configured for CO<sub>2</sub> capture. The fixed operating costs and the maintenance and material costs in this case were assumed to be equal to the values in DOE case 12 of the cost updates to the Bituminous Baseline Study.<sup>2</sup>

**Table 19.** Annual costs from power plant modeling of Case H.

			Annual Cost	Annual Unit Cost
			\$	\$/kWh-net
<b>Fixed Operating Costs</b>			<b>\$ 61,032,475</b>	<b>\$ 0.01262</b>
<b>Maintenance Material Costs</b>			\$ 18,136,161	\$ 0.00375
	Consumption / day	Unit Cost		
Water (/1000 gallons)	4,647	1.67	\$ 2,407,817	\$ 0.00050
Chemicals				
MU & WT Chem. (lbs)	22,493	0.27	\$ 1,884,197	\$ 0.00039
Limestone (ton)	638	33.48	\$ 6,625,304	\$ 0.00137
Ammonia (19% NH <sub>3</sub> ) ton	97	330	\$ 9,961,176	\$ 0.00206
<b>Subtotal Chemicals</b>			<b>\$ 18,470,677</b>	<b>\$ 0.00382</b>
Other				
SCR Catalyst (m <sup>3</sup> )	0.41	5775.94	\$ 730,381	\$ 0.00015
<b>Subtotal Other</b>			<b>\$ 730,381</b>	<b>\$ 0.00015</b>
Waste Disposal				
Total Ash (ton)	627	25.11	\$ 4,882,568	\$ 0.00101
<b>Subtotal Waste Disposal</b>			<b>\$ 4,882,568</b>	<b>\$ 0.00101</b>
<b>Total Variable Operating Costs</b>			<b>\$ 26,491,442</b>	<b>\$ 0.00548</b>
Fuel (ton)	6461	68.60	\$ 137,516,215	\$ 0.02844

Table 20 details the energy flows in and out of the control volume of the full power plant model with CO<sub>2</sub> capture.

**Table 20.** Energy balance from power plant modeling of Case H.

	HHV	Sensible + Latent Heat	Power	Total
Heat In (MMBtu/hr)				
Coal	6296			6296
Ambient Air		69.9		69.9
FGD Water		29.0		29.0
FGD Oxidation Air		6.6		6.6
Totals	6296	105		6401
Heat Out (MMBtu/hr)				
Bottom Ash		5.8		5.8
Fly Ash + FGD Ash		2.3		2.3
Flue Gas		590		590
HP CO <sub>2</sub>		139		139
Unburned Carbon		17.4		17.4
Boiler Losses		55.3		55.3
Fuel Delivery Losses		2.9		2.9
Main Condenser		3124		3124
BFPT Condenser		410		410
Steam Piping Losses		14.3		14.3
ST/Generator Mech/Elec/Gear Losses		25.0		25.0
BFPT Mech Losses		0.9		0.9
Pumps Mech/Elec Losses		3.0		3.0
Fans Mech/Elec Losses		5.0		5.0
FGD Energy Losses		42.0		42.0
Misc Losses and Auxiliaries		80.7		80.7
Net Power			1884	1884
Totals	0	4517	1884	6401

Table 21 shows the air emissions for Case H.

**Table 21.** Air emissions for Case H (based on net power).

	lb/MMBtu
SO <sub>2</sub>	~0
NO <sub>x</sub>	0.3
Particulates	~0
Hg	~0
CO <sub>2</sub>	72.3

The carbon balance for Case H is shown in Table 22.

**Table 22.** Carbon balance for Case H.

Carbon In, (lb/hr)		Carbon Out (lb/hr)	
Coal	343,255	Stack Gas	37,153
Air (CO <sub>2</sub> )	667	FGD Product	2,216
FGD Reagent	5,436	CO <sub>2</sub> Product	309,989
<b>Total</b>	<b>349,358</b>	<b>Total</b>	<b>349,358</b>

The sulfur balance for Case H is shown in Table 23.

**Table 23.** Sulfur balance for Case H.

Sulfur In, (lb/hr)		Sulfur Out (lb/hr)	
Coal	13,515	FGD Product	13,481
		Stack Gas	0
		Waste Solvent	34
<b>Total</b>	<b>13,515</b>	<b>Total</b>	<b>13,515</b>

Table 24 summarizes the pieces of equipment which contribute to the total water consumption in the power plant model with CO<sub>2</sub> capture.



**Table 21.** Water consumption for power plant modeling of Case H.

Water Use	Water Consumption (gpm)
FGD Makeup	754
Cooling Tower	5,702
<b>Total</b>	<b>6,456</b>

## Economic Analysis

CAPEX estimations for the carbon-capture island were completed for MEA and the aminosilicone-based cases in order to calculate the first year COE, first year removal cost of CO<sub>2</sub>, and first year avoided cost of CO<sub>2</sub>. The annual costs were estimated as follows:

Annual cost includes the following items:

- Power Island – CAPEX, OPEX, and fuel - The estimated values were compared against DOE estimated values for Case 11 of the cost updates for the Bituminous Baseline Study.<sup>2</sup> Further estimates were conducted for a power island that would be required for 550 MW net power with carbon capture using aminosilicone-based solvent.
- Capital recovery and other fixed charges- The recovery charges are dependent on the Capital Charge Factor (CCF). The CCF used in this study was chosen based on NETL’s cost estimation methodology using the case for High risk IOU for five years.<sup>6</sup>
- Cost of cooling water- The cost of cooling water from the Bituminous Baseline Study was used for the non-scaled cases.<sup>2</sup> For the scaled-up cases, the increased cooling water demand increased cooling tower CAPEX and OPEX.
- CO<sub>2</sub> transport, storage and monitoring- \$10/tonne as provided by DOE in the cooperative agreement.
- Solvent cost- Solvent cost of \$20/lb was used in this study. This solvent cost is based off of the estimates made for solvent cost in the previous DOE award (DE-FE0007502). Further, a sensitivity analysis was conducted with respect to solvent cost, which is provided in the subsequent section.
- Fixed O&M costs- Estimated using a plant on stream factor of 310.25 days and a charge of \$875/day.
- Maintenance and material cost- Estimated using 1.6% of the material cost.

The details of the calculations are provided below

Power Island – CAPEX, OPEX, and Fuel – this cost is the same for all non-scaled cases. It can also be calculated using the expression below:

$$\text{Power island cost} = \text{COE} \cdot \text{power generated}$$

COE, which is used in this expression, is equal to 80.95 mils/kWh, from Case 11 COE w/o TS&M.<sup>2</sup>

For the scaled-up cases, the cost was estimated using Thermoflow calculations.

### Capital Recovery and other Fixed Charges

The capital recovery was calculated based on the following formula:

$$\text{Capital recovery} = \text{Capital charge factor} * \text{installed CAPEX}$$

The capital charge factor (CCF) value is selected based on several factors:

- Type of power plant financial structure (IOU vs. IPP)
- High risk or low risk finance structure
- Capital expenditure period: three years vs. five years.

Table 25 reports capital charge factors for a variety of finance structures.<sup>6</sup>

**Table 22:** Capital charge factors for various finance structures.

Finance Structure	High Risk IOU		Low Risk IOU	
Capital Expenditure Period	Three Years	Five Years	Three Years	Five Years
Capital Charge Factor (CCF)	0.111	0.124	0.105	0.116
Finance Structure	High Risk IPP		Low Risk IPP	
Capital Expenditure Period	Three Years	Five Years	Three Years	Five Years
Capital Charge Factor (CCF)	0.177	0.214	0.149	0.176

The value selected for the post-combustion CO<sub>2</sub>-capture process is 12.4%, which corresponds to a high risk IOU structure with a five year capital expenditure period.

First year COE was calculated based on the following formula:

$$\text{COE} = \frac{\text{total annual costs}}{\text{power generated}}$$

First year removal cost for CO<sub>2</sub> was calculated using the expression below:

$$\text{Removal cost} \left( \frac{\$}{\text{ton}} \right) = \frac{\text{COE}_{\text{with capture}} - \text{COE}_{\text{without capture}}}{\text{lb of CO}_2 \text{ separated} * \text{power generated}}$$

### Total Cost of Cooling Water

The total cost of cooling water was determined based on the amount of cooling water required as predicted by the ASPEN Plus model for the carbon-capture process and the cost of cooling water.

### CO<sub>2</sub> Transport, Storage, and Monitoring

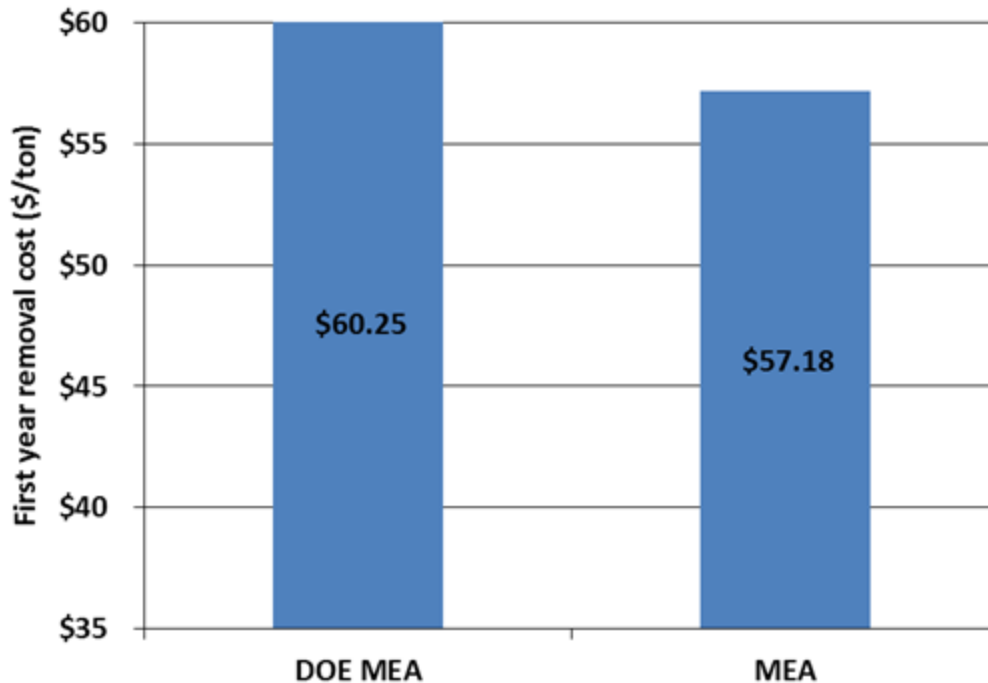
This cost was calculated based on the amount of CO<sub>2</sub> separated and the cost of transportation, storage, and Monitoring (TS&M).

### Maintenance Material Costs

The maintenance material costs were calculated from the formula below:

$$\begin{aligned} & \textit{Maintenance material costs} \\ & = \textit{Equipment and material costs} * \textit{Maintenance and material cost \%} \end{aligned}$$

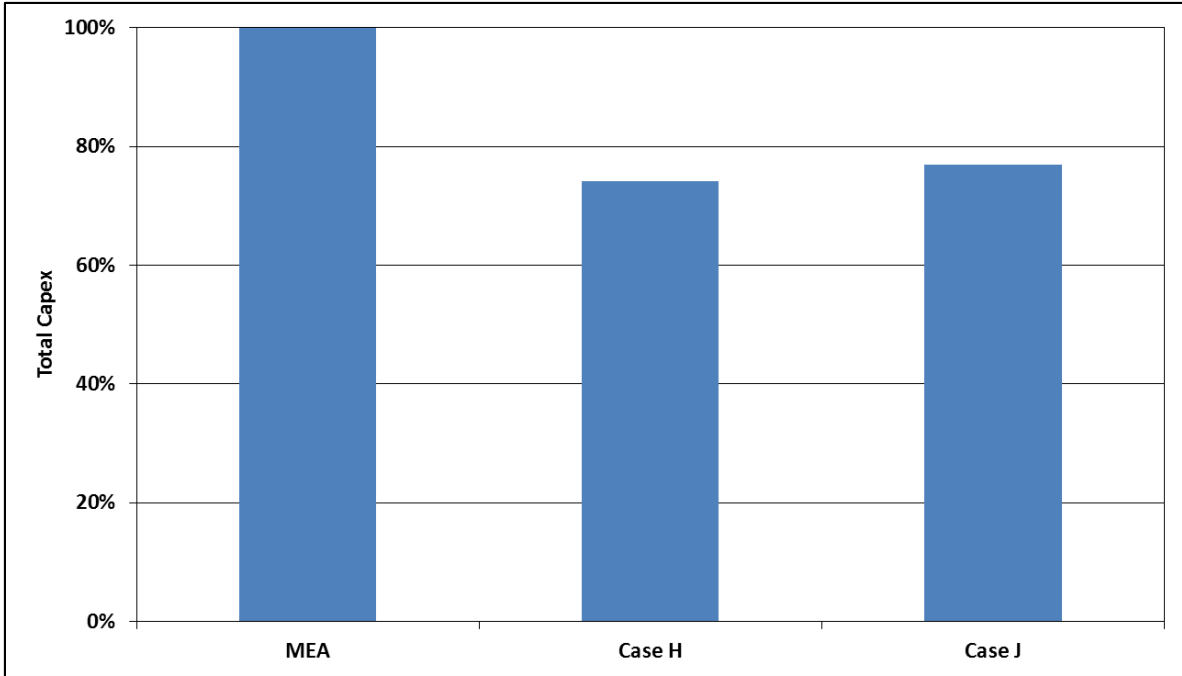
The first year removal cost of CO<sub>2</sub> was estimated for a supercritical power plant with carbon capture using MEA as a solvent. The results are shown in Figure 15 as compared to Case 12 in the Bituminous Baseline Study Cost Update.<sup>2</sup> The values are in good agreement with each other.



**Figure 7.** Comparison of first year removal cost of CO<sub>2</sub> using MEA vs. DOE estimated value.<sup>2</sup>

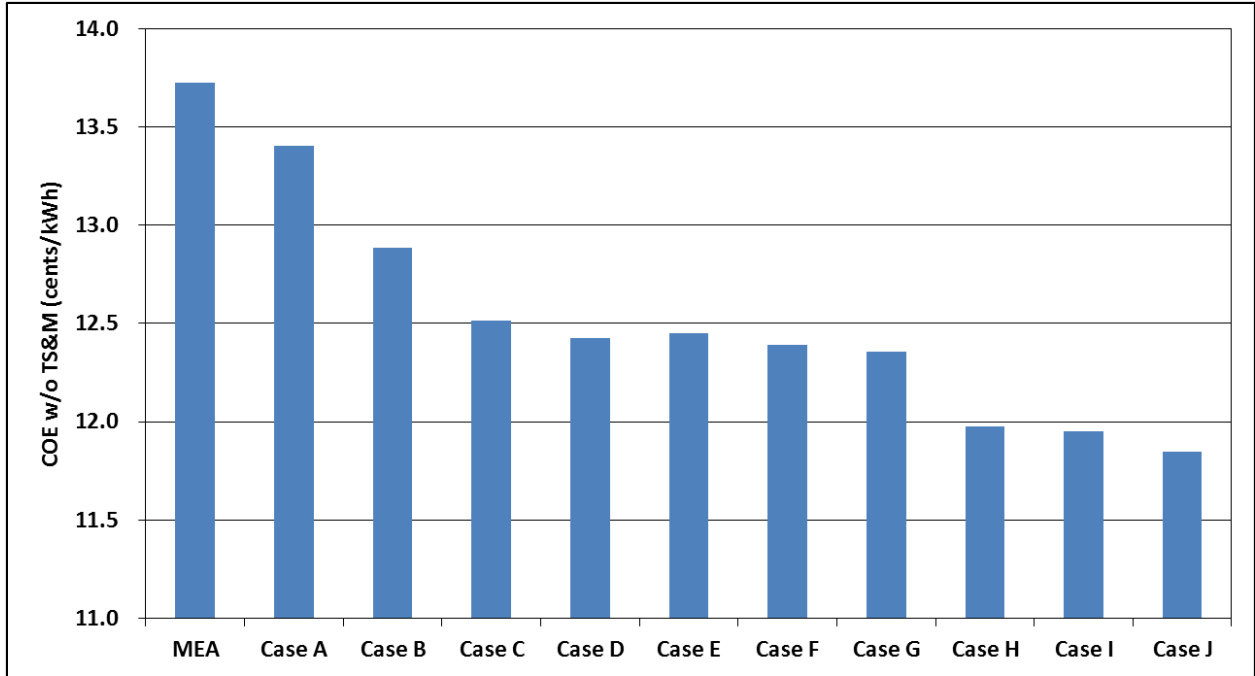
The removal cost was estimated for a supercritical power plant using the aminosilicone-based material as a solvent for carbon capture. As mentioned earlier for the first few cases (Case A-G) the power plant island was taken as the same size as Case 11 in the Bituminous Baseline Study.<sup>1</sup> This was done to determine the effect of different parameters of the carbon-capture island on process economics without changing the size and other variables of the power island. Once a best case was found for the conditions of the carbon-capture island, then the scale was adjusted to get to a 550 MW net power with carbon capture (shown as Case H-J).

Capital cost estimations for the aminosilicone cases were done using Aspen Cost Estimator with a cost basis of Q1, 2010. The costs were then adjusted using the CEPCI index to get a final cost basis of 2011. The total CAPEX for the DOE Case 12 as compared to Case H and Case J are shown in Figure 16. As seen in the figure, Case H is <75% and Case J is <77% of the CAPEX of a system using MEA solvent. The higher CAPEX for Case J as compared to Case H is due to the increased CAPEX due to heat integration.

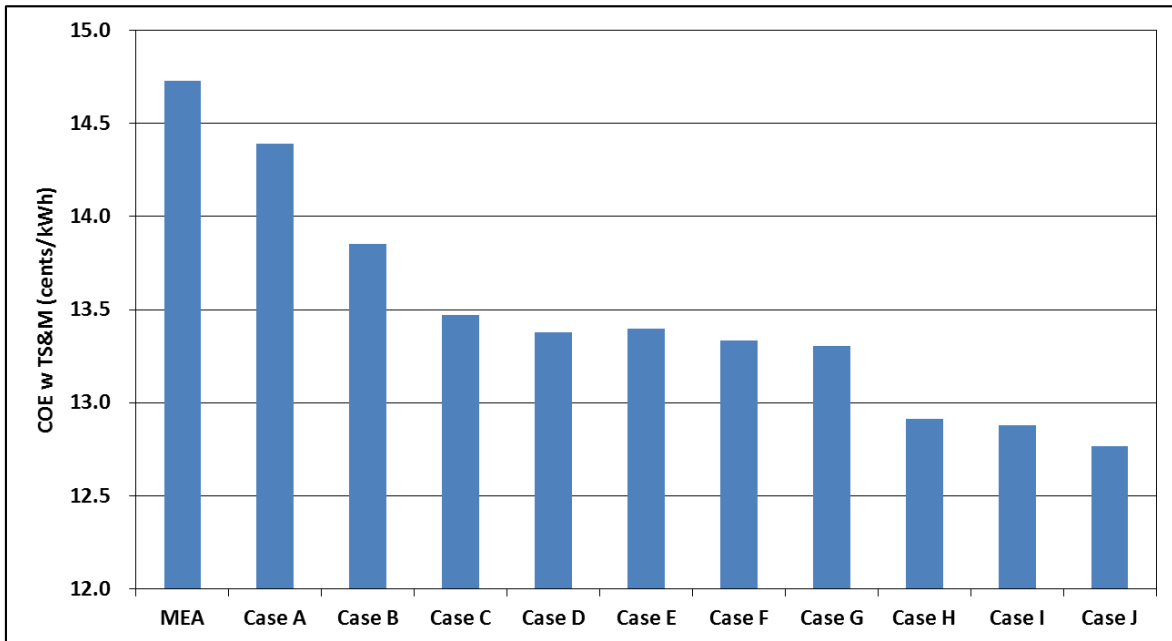


**Figure 8.** Total CAPEX comparison of two scaled-up cases using aminosilicone solvents vs. DOE Case 12 using MEA.

First year COE was calculated (with and without TS&M) as shown in Figure 17 and Figure 18. Case J COE w/o TS&M is 11.85 as compared to 13.73 cents/kWh for the MEA based system. When TS&M is included in the analysis, then Case J COE is 12.77 vs. 14.73 cents/kWh for the MEA based system.

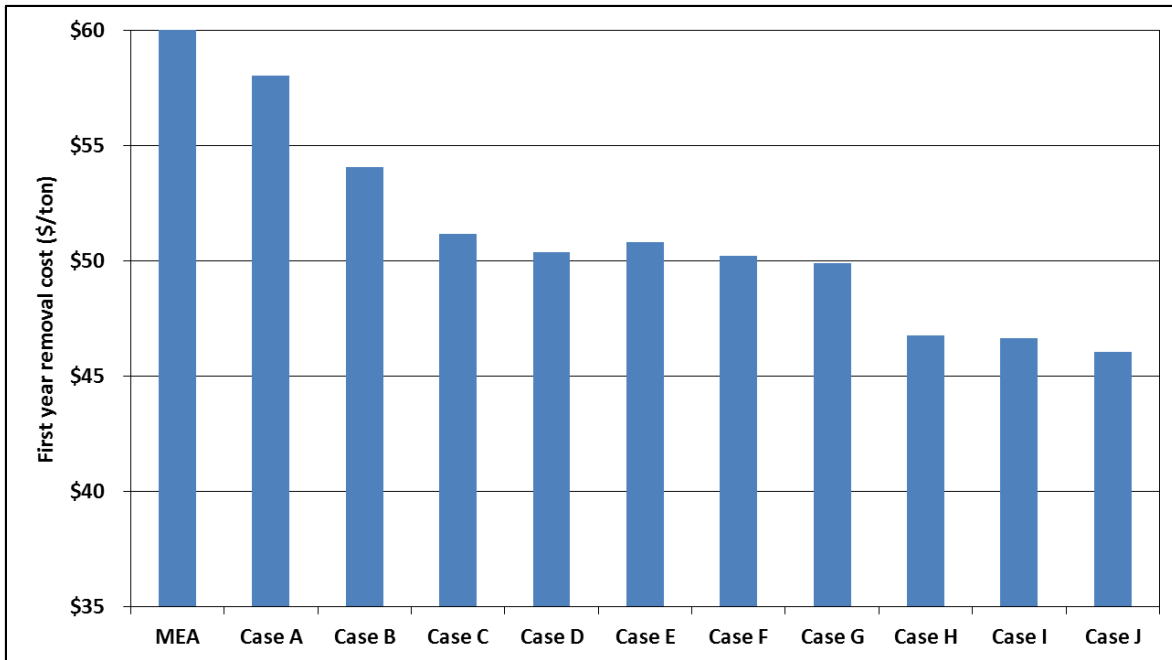


**Figure 9.** Cost of electricity without TS&M for various cases as compared to DOE Case 12.



**Figure 18.** Cost of electricity with TS&M for various cases as compared to DOE Case 12.

The first year removal cost of CO<sub>2</sub> for Case J is \$46.04/ton of CO<sub>2</sub> as compared to \$60.25/ton of CO<sub>2</sub> when MEA is used. This shows a significant reduction in removal cost when aminosilicone solvent is used for carbon capture.



**Figure 19.** First year removal cost of CO<sub>2</sub> in \$/ton for various cases as compared to DOE Case 12.

## Sensitivity Analysis

In order to understand the effect of the main parameters on the cost of CO<sub>2</sub> removal and efficiency of the power plant, the sensitivity analysis was conducted with respect to the following parameters:

- Heat rate of the desorber
- Auxiliary load of the pumps and compressors for CO<sub>2</sub> capture island
- Required amount of cooling water
- Installed CAPEX of CO<sub>2</sub>-capture island
- Power island capital cost
- Solvent cost
- Sulfur amount in incoming flue gas

The results of the sensitivity analysis are presented below.

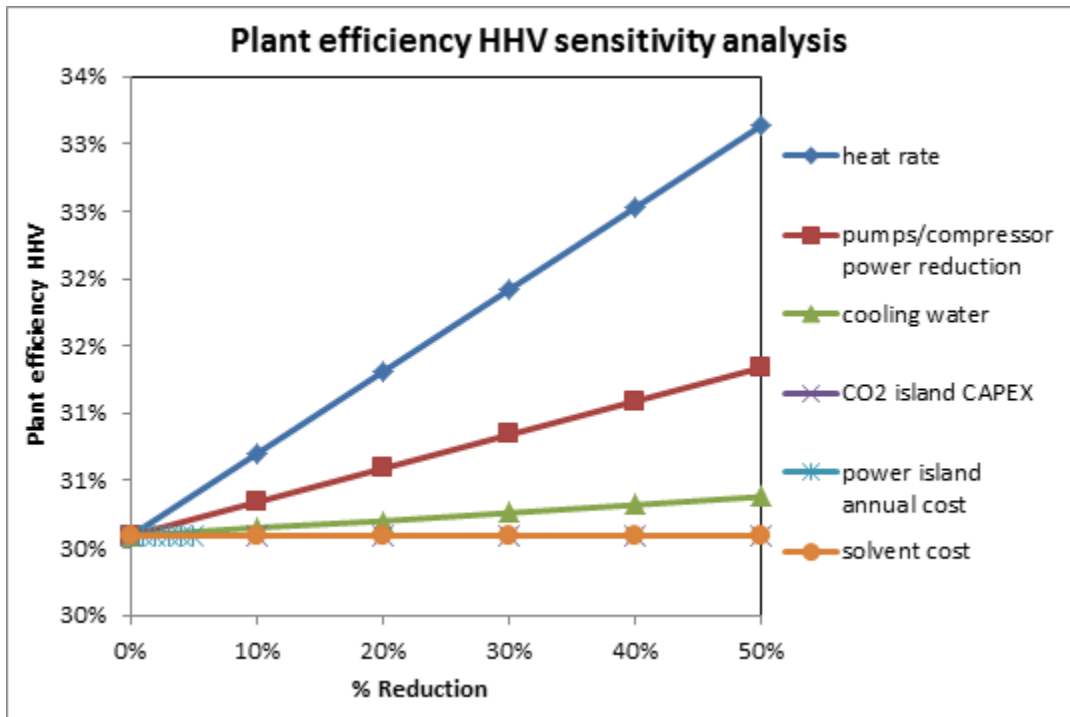


Figure 20. Sensitivity analysis of effect of different variables on plant efficiency for Case H.

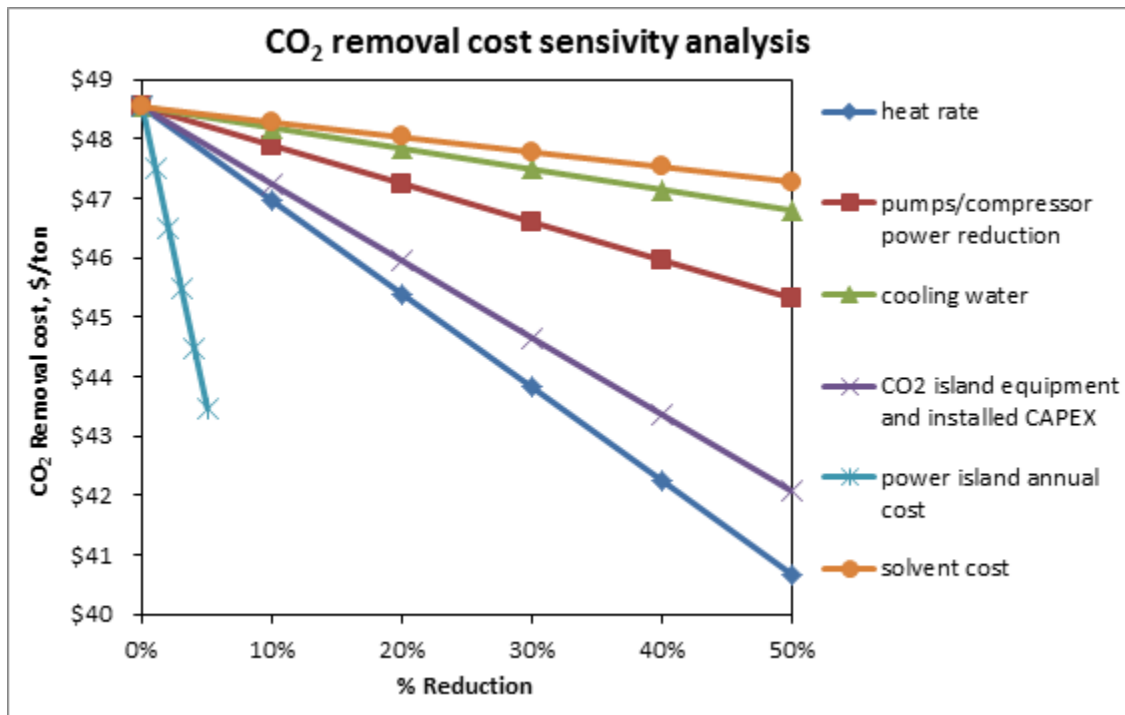
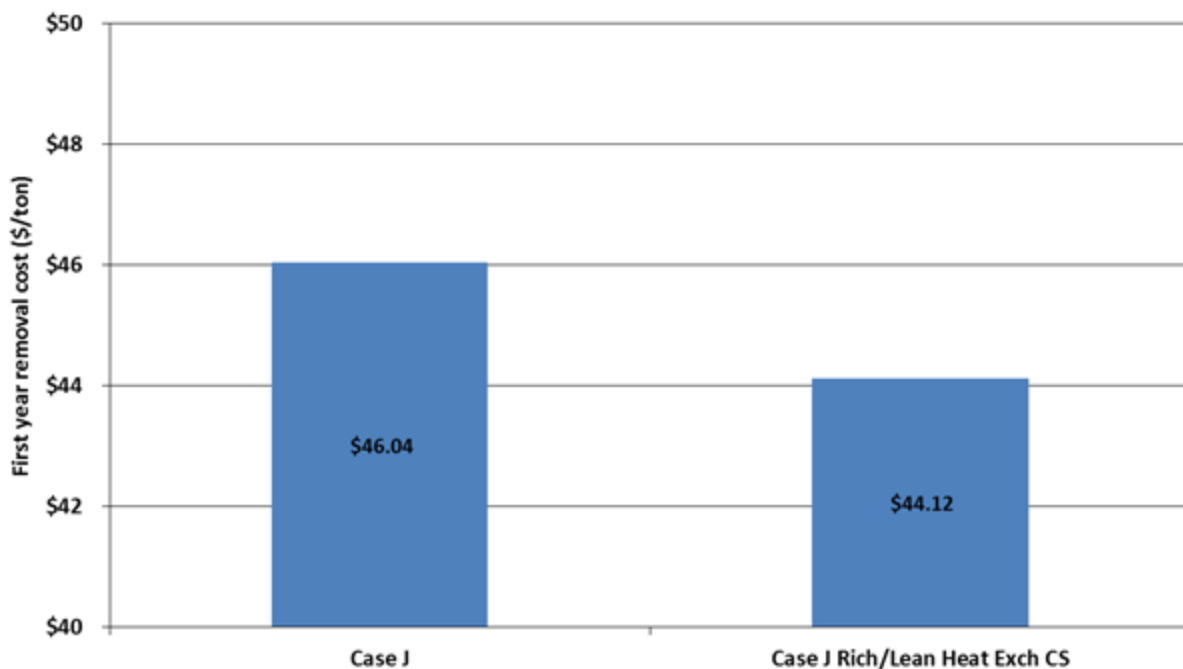


Figure 21. Sensitivity analysis of effect of different variables on removal cost of CO<sub>2</sub> for Case H.



It can be seen from these plots, that Installed CAPEX of the CO<sub>2</sub>-capture island and desorber heat rate have the most significant impact on CO<sub>2</sub> removal cost. Cooling water amount, auxiliary power, and solvent cost have a lesser effect.

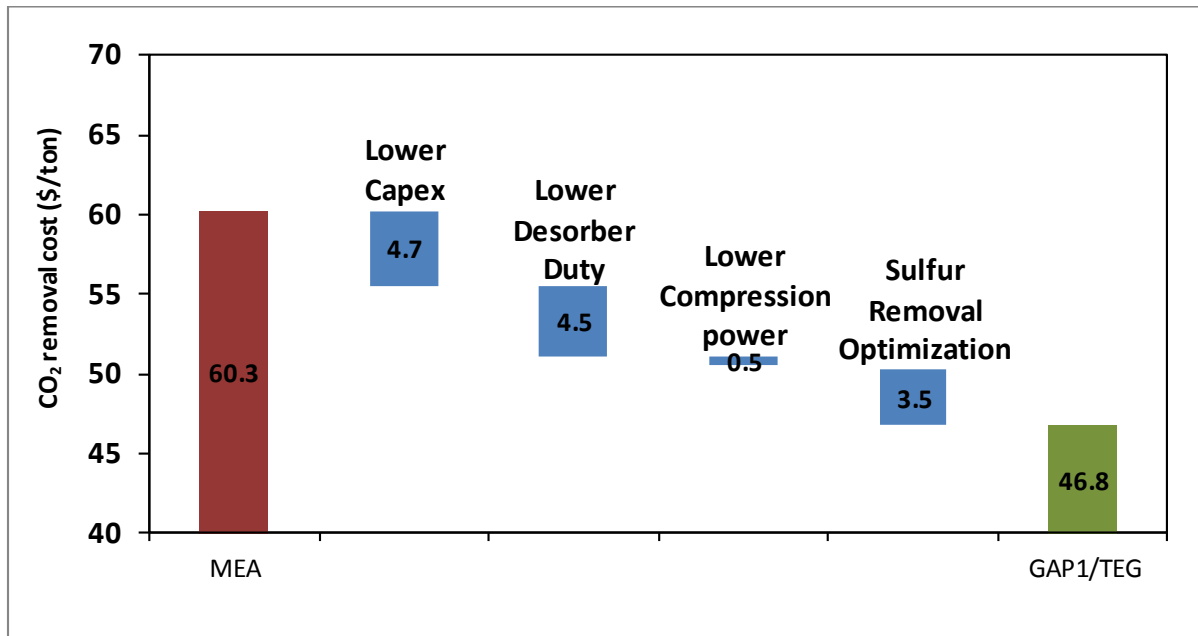
As mentioned earlier, the rich-lean heat exchanger represents ~25% of the total equipment cost for the CO<sub>2</sub>-capture process. Decreasing the cost of this unit can significantly decrease the cost of CO<sub>2</sub> removal using an aminosilicone-based carbon-capture process. Figure 22 shows the first year removal costs for Case J, which has a stainless steel rich-lean heat exchanger. Stainless steel was used because, in corrosion tests conducted under the previous DOE award (DE-FE0007502), significant corrosion of carbon steel was observed in the high-temperature desorber at the bench scale, whereas no significant corrosion was observed with stainless steel. However, there are a number of corrosion inhibitors that may be used to decrease the corrosion of carbon steel in the hotter portions of the carbon-capture system. If these inhibitors decrease corrosion enough, carbon steel could be used in the rich-lean heat exchanger. To show the impact on CO<sub>2</sub> removal cost, Figure 22 also shows results for Case J, but with the stainless steel rich-lean heat exchanger replaced by a carbon steel exchanger. Replacing the stainless steel exchanger with a carbon steel model decreases the first year removal cost from \$46.04/ton to \$44.12/ton.



**Figure 22.** A comparison of the impact of materials of construction of the rich-lean heat exchanger on CO<sub>2</sub> removal costs. Case J (left bar) has a stainless steel rich-lean heat exchanger. Case J Rich/Lean Heat Exch CS has a carbon steel exchanger.

## Aminosilicone Process Advantage over MEA

It has been shown that the aminosilicone process is a more cost-effective technology for capturing CO<sub>2</sub> from the flue gas of coal power plants, with removal cost of \$46.80/ton for Case H compared to \$60/ton for MEA technology. After thermal optimization with the power plant, the removal cost is further reduced to \$46.04/ton. Figure 23 summarizes the advantages of the aminosilicone process over MEA.



**Figure 23.** Summary of major benefits of GAP-1m/TEG CO<sub>2</sub>-capture system vs. MEA.

The lower CAPEX of the CO<sub>2</sub>-capture process using aminosilicone-based solvent contributes to ~\$4.7/ton decrease in CO<sub>2</sub> removal cost. There are several factors which reduce the CAPEX:

- 1) Aminosilicone-based solvent offers larger working capacity than MEA by a factor of 1.3-1.7, which reduces the overall mass flow rate of solvent in the system by 20%. Such reduction in flow rate reduces the size of the overall system, and therefore the CAPEX.
- 2) Aminosilicone-based solvent has higher thermal stability than MEA, which allows the desorption of CO<sub>2</sub> to be conducted at higher temperature and pressures. The CO<sub>2</sub> stream leaving the desorber is at 63 psia vs. 26 psia for MEA, and therefore the size of the first stage of compression can be reduced, and capital cost decreased.

- 3) The low vapor pressure of the aminosilicone-based solvent allows the desorption of CO<sub>2</sub> to be conducted in a CSTR versus packed tower, and it further reduces the cost of the desorption system.

Lower desorber duty for the aminosilicone-based process contributes to ~\$4.5/ton reduction in CO<sub>2</sub> removal cost. There are two main factors which contribute to decreased total desorber duty:

- 1) Aminosilicone-based solvent has lower heat capacity compared to MEA, which reduces sensible heat duty for the desorber.
- 2) As it was mentioned above, larger working capacity reduces the overall mass flow rate of the solvent in the system, and helps to reduce overall heat duty on the desorber.

Lower compression power contributes to ~\$0.5/ton reduction in CO<sub>2</sub> removal cost. Due to the higher thermal stability of the aminosilicone-based solvent, the desorption process can be conducted at higher temperatures and pressure. Therefore, the CO<sub>2</sub> stream leaving the desorber is at ~2.4 higher pressure compared to MEA, and compression load is significantly reduced.

Lower solvent loss in the aminosilicone-based process decreases CO<sub>2</sub> removal cost by ~\$3.5/ton. This loss is reduced by modifying the operation of the FGD to reduce the amount of sulfur oxide in the flue gas to 5 ppm. Also, because the aminosilicone-based solvent is much more thermally stable than MEA, the loss due to thermal degradation is minimal.

## Conclusions:

System and economic analysis for a carbon capture unit which uses an aminosilicone-based solvent for CO<sub>2</sub> capture and sequestration (CCS) in a pulverized coal (PC) boiler demonstrates that the amino-silicone solvent has significant advantages relative to an MEA-based system. The aminosilicone solvent is a 60/40 wt/wt mixture of 3-aminopropyl end-capped polydimethylsiloxane (GAP-1m) with tri-ethylene glycol (TEG) as a co-solvent. For comparison purposes, the report also shows results for a carbon-capture unit based on a conventional approach using mono-ethanol amine (MEA).

The first year removal cost of CO<sub>2</sub> for the aminosilicone-based carbon-capture process is \$46.04/ton of CO<sub>2</sub> as compared to \$60.25/ton of CO<sub>2</sub> when MEA is used. The aminosilicone-based process has <77% of the CAPEX of a system using MEA solvent. The lower CAPEX is due to several factors, including the higher working capacity of the aminosilicone-based solvent compared the MEA, which reduces the solvent flow rate required, reducing equipment sizes. If it is determined that carbon steel can be used in the rich-lean heat exchanger in the carbon

capture unit, the first year removal cost of CO<sub>2</sub> decreases to \$44.12/ton. The aminosilicone-based solvent has a higher thermal stability than MEA, allowing desorption to be conducted at higher temperatures and pressures, decreasing the number of compressor stages needed. The aminosilicone-based solvent also has a lower vapor pressure, allowing the desorption to be conducted in the continuous-stirred tank reactor versus a more expensive packed column. The aminosilicone-based solvent has a lower heat capacity, which decreases the heat load on the desorber. In summary, the amino-silicone solvent has significant advantages over conventional systems using MEA.