

Calibration of Molar Quantity for Gas in a Vacuum Manifold with Extreme Temperature Variations

Henry Peebles, Mark Benner, Thomas Mehrhoff^{*},
Carol Mehrhoff[†], Robin Ohlhausen
and Heather Richard

Sandia National Laboratories
Albuquerque, NM

^{*} *Independent contractor for Sandia National Laboratories*

[†] *Retired*

Sandia National Laboratories is a multi-program laboratory operated by Sandia Corporation, a wholly owned subsidiary of Lockheed Martin company, for the U.S. Department of Energy's National Nuclear Security Administration under contract DE-AC04-94AL85000.

Load Measurements on Thin Metal Hydride Films

Need molar quantity of gas captured in manifold + trap + bell jar

$$N_T = \frac{P}{R} \cdot \sum \left(\frac{V_i}{T_i} \right)$$

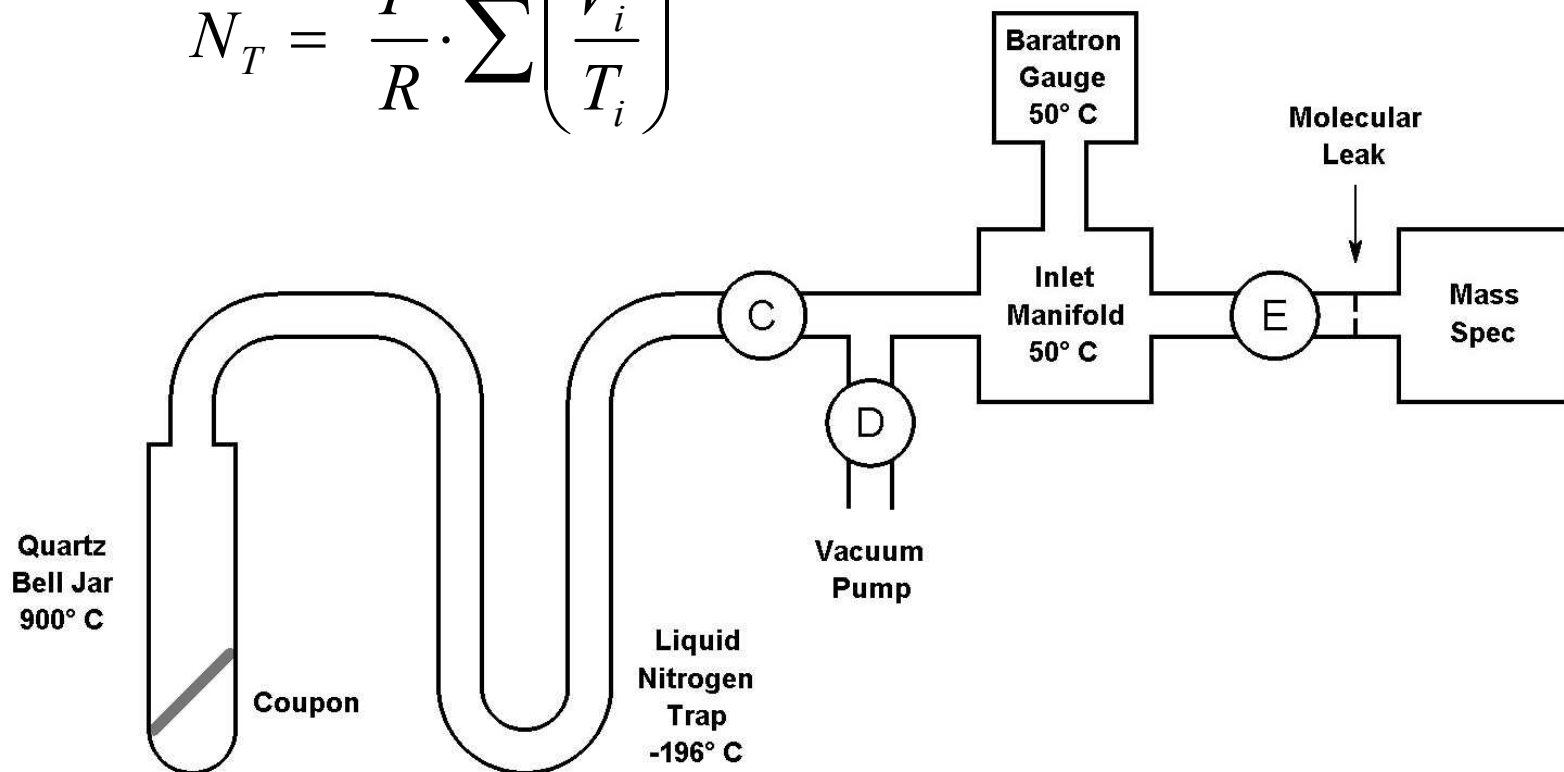

Molar Response of Baratron Can Be Measured Experimentally

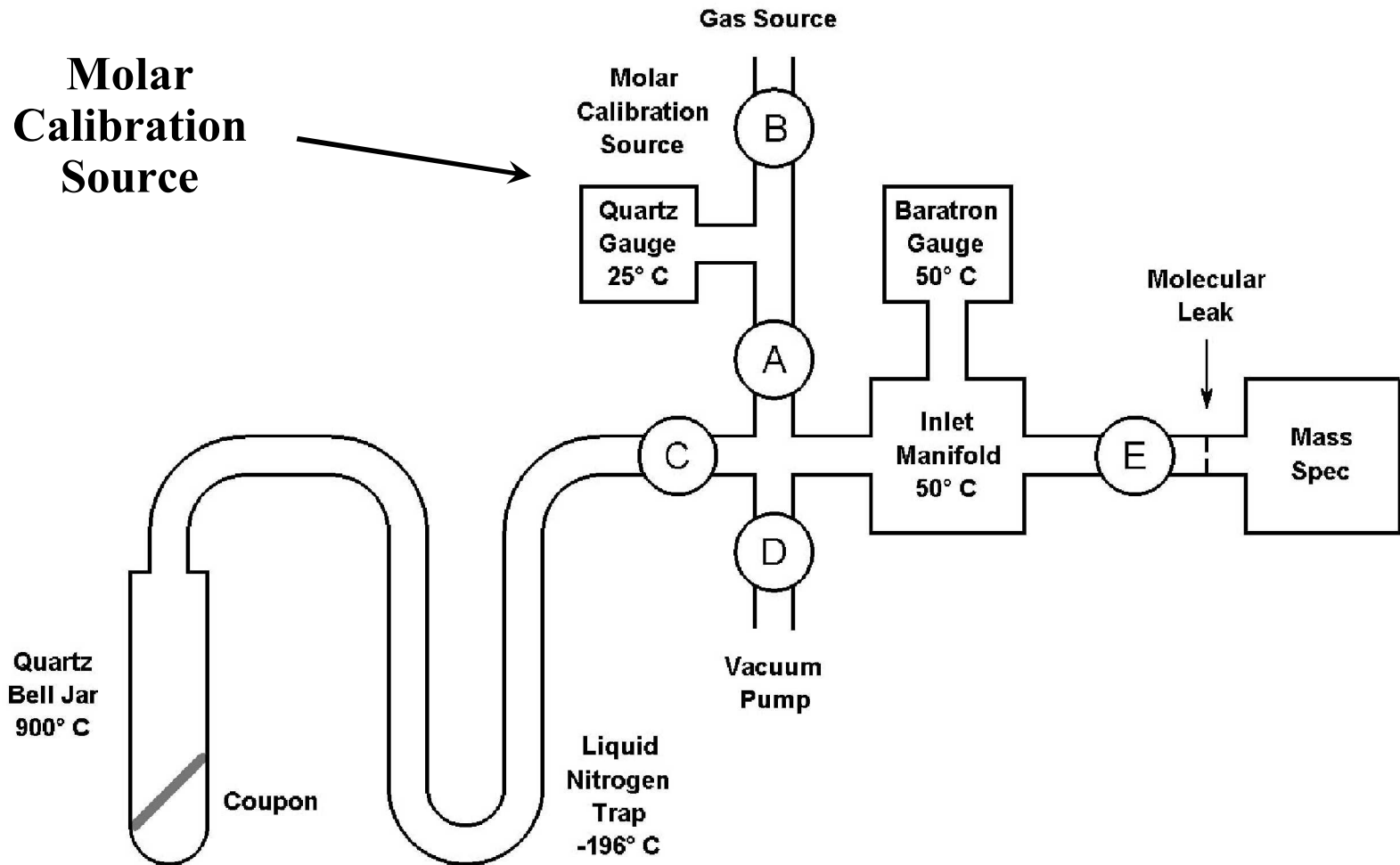

Experimental Calibration Curve for Manifold + Trap + Bell Jar

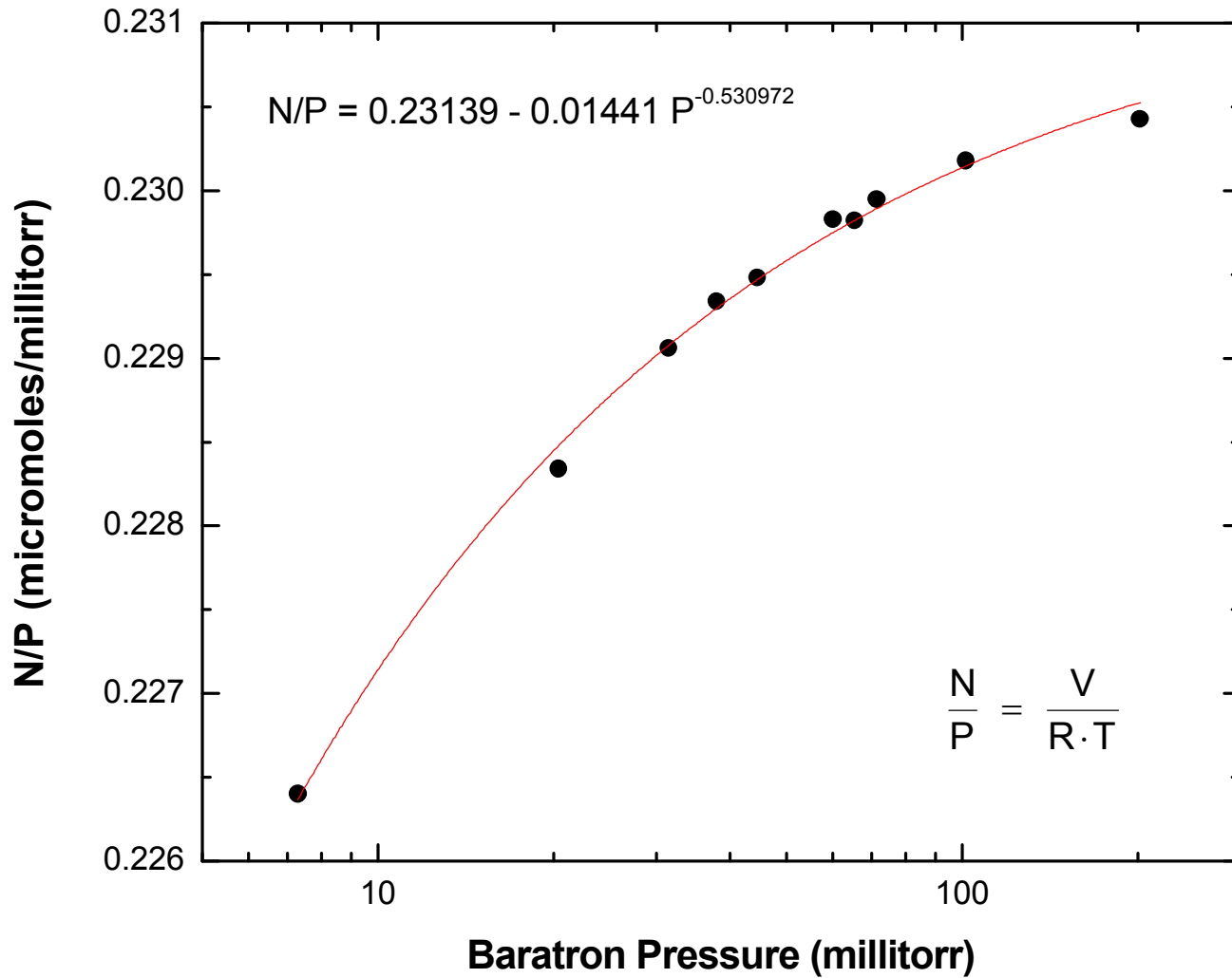

Molar Calibration Source



Paroscientific 6000-15A

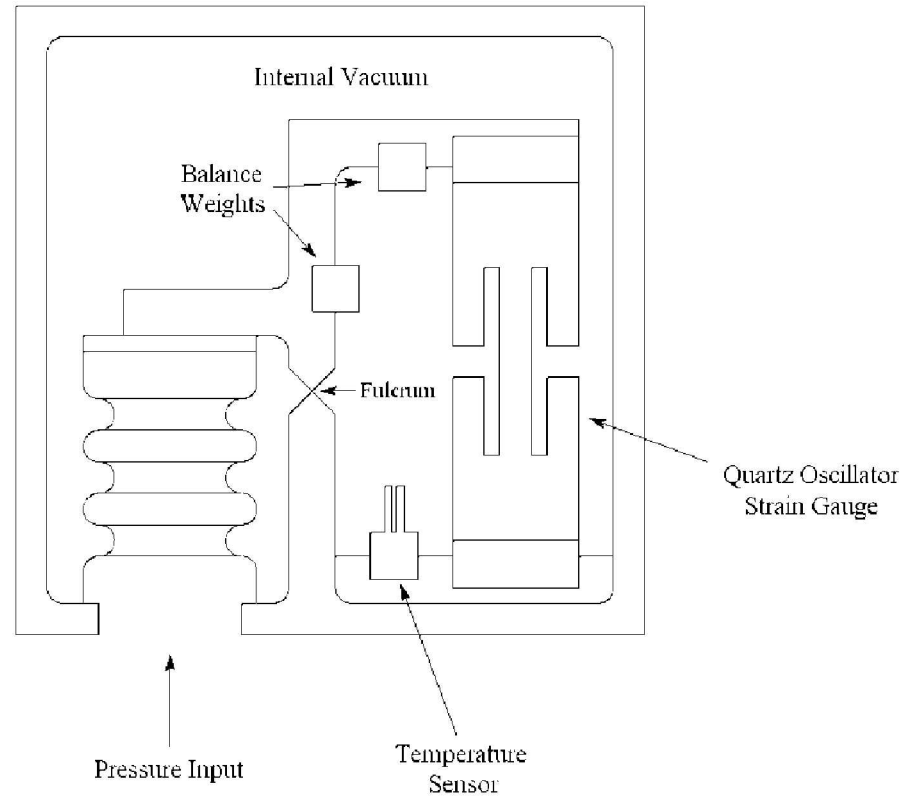

15 to 775 torr, 3.7 mL

Internal Volume is Constant as a Function of Pressure

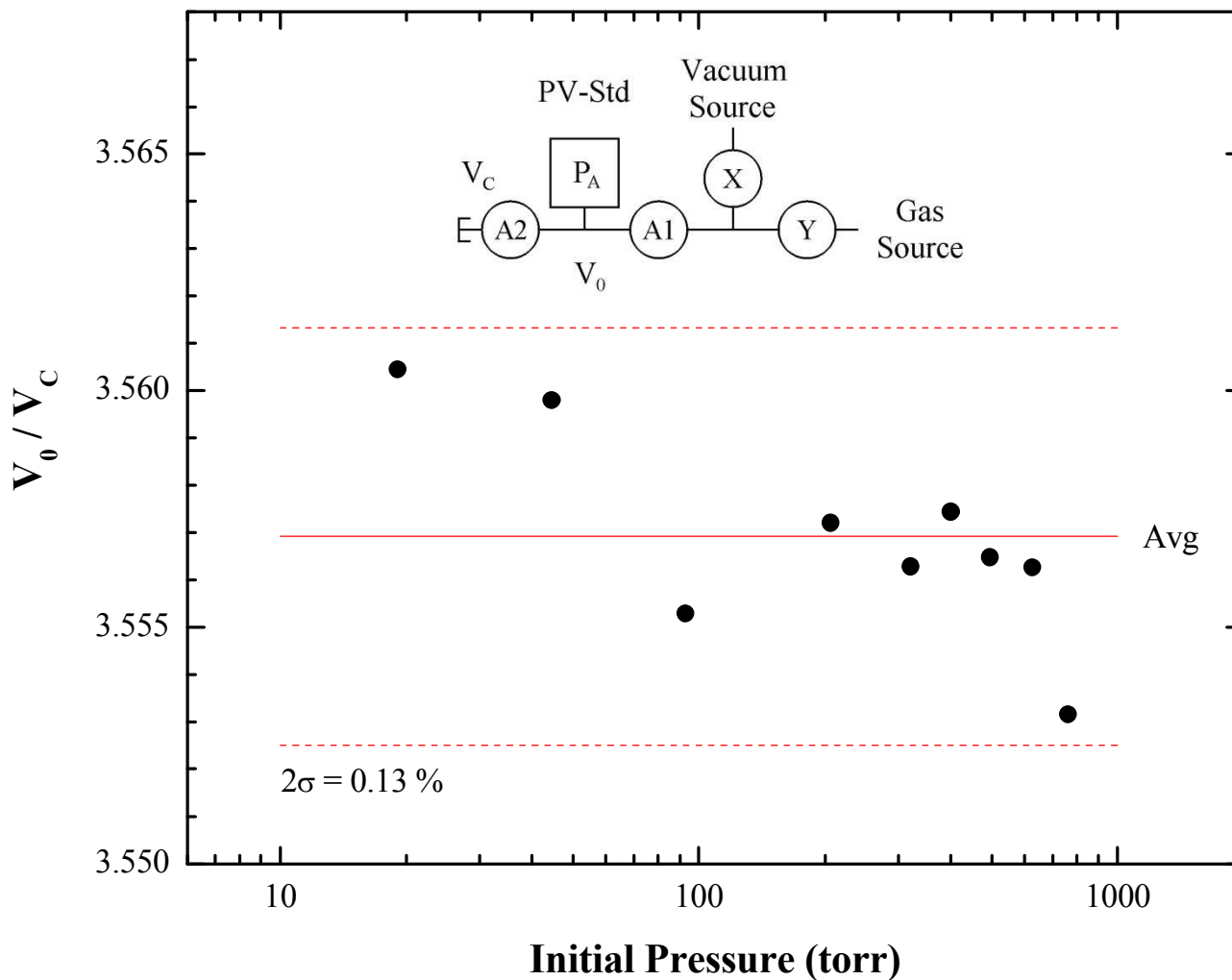



Uncertainty Estimate (2σ)

$$\left(\frac{\partial N}{N}\right)^2 = \left(\frac{\partial V_0}{V_0}\right)^2 + \left(\frac{\partial P_0}{P_0}\right)^2 + \left(\frac{\partial T_0}{T_0}\right)^2 + \left(\frac{2\sigma_{fit}}{N_{avg}}\right)^2$$

$$\left(\frac{\partial N}{N}\right)^2 = (0.83\%)^2 + (0.20\%)^2 + (0.34\%)^2 + (0.39\%)^2$$

$$\frac{\partial N}{N} = 1.0\%$$

CY 2005 N/P Control Chart F+3L+BJT

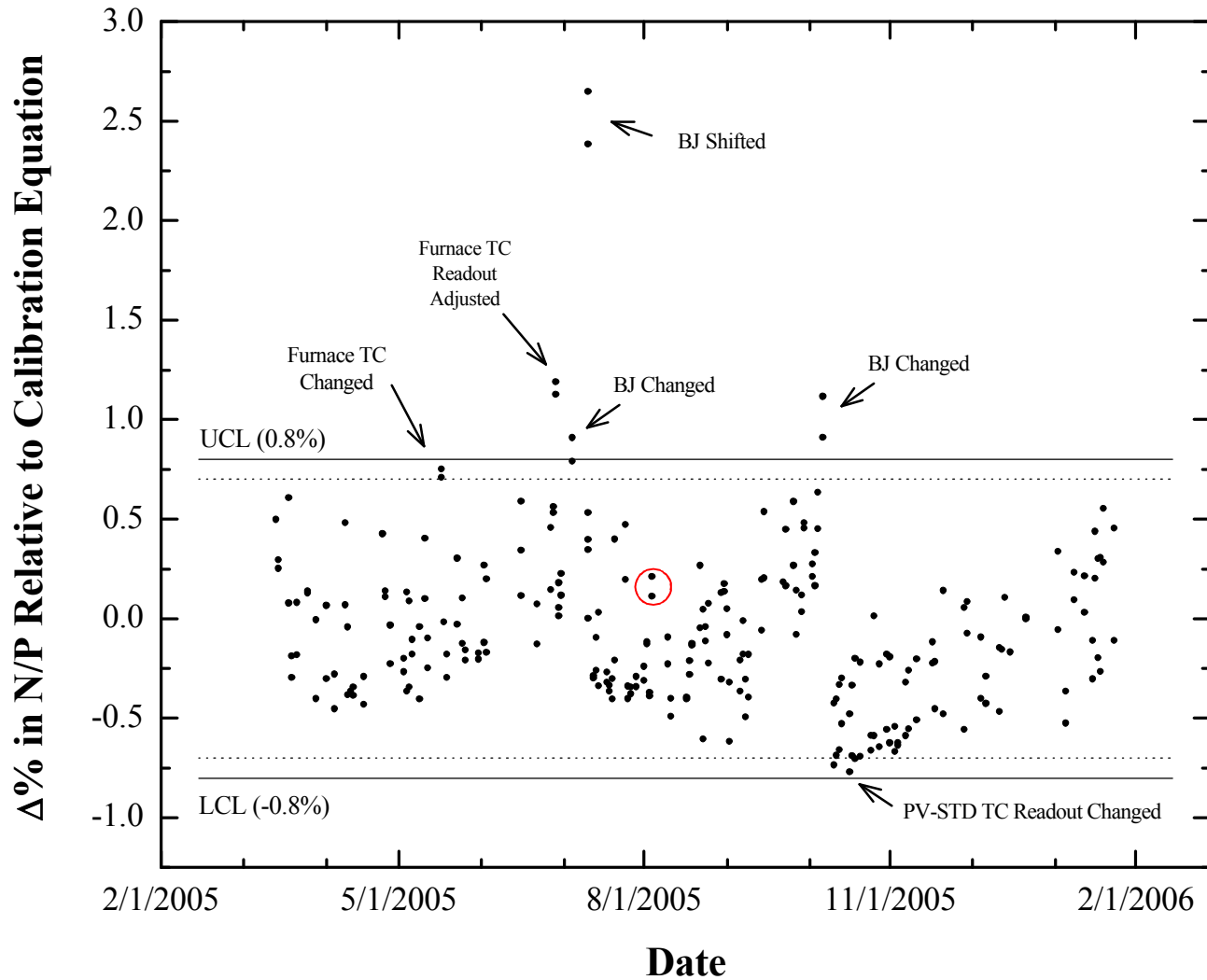

Post Clean-up Recalibration Data Comparison

MS-1 N/P Function F+3L+BJT, 2-2-06 vs 8-22-06

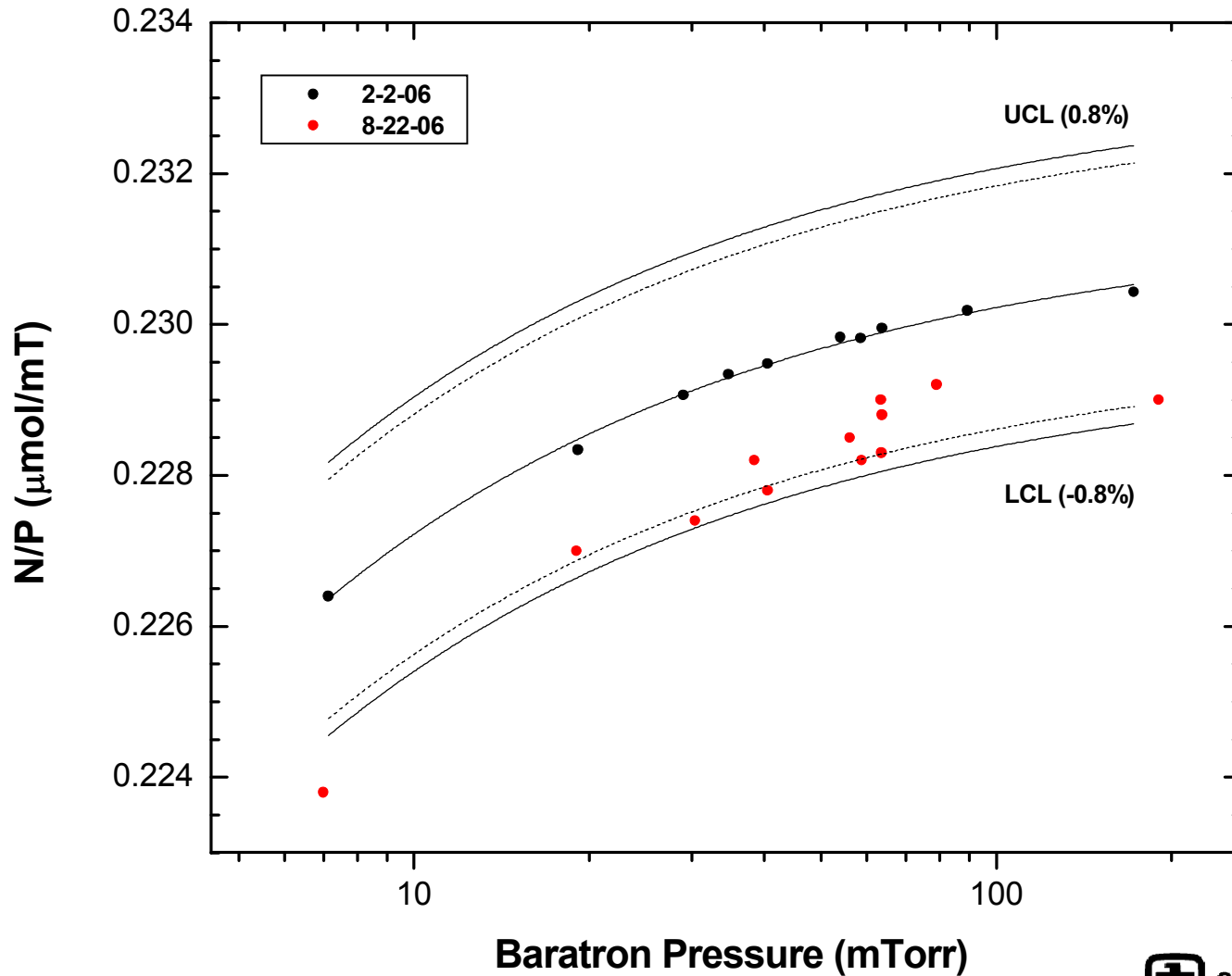

N/P Function for a Volume at Constant Temperature

MS-1 N/P Function F+3L+6L

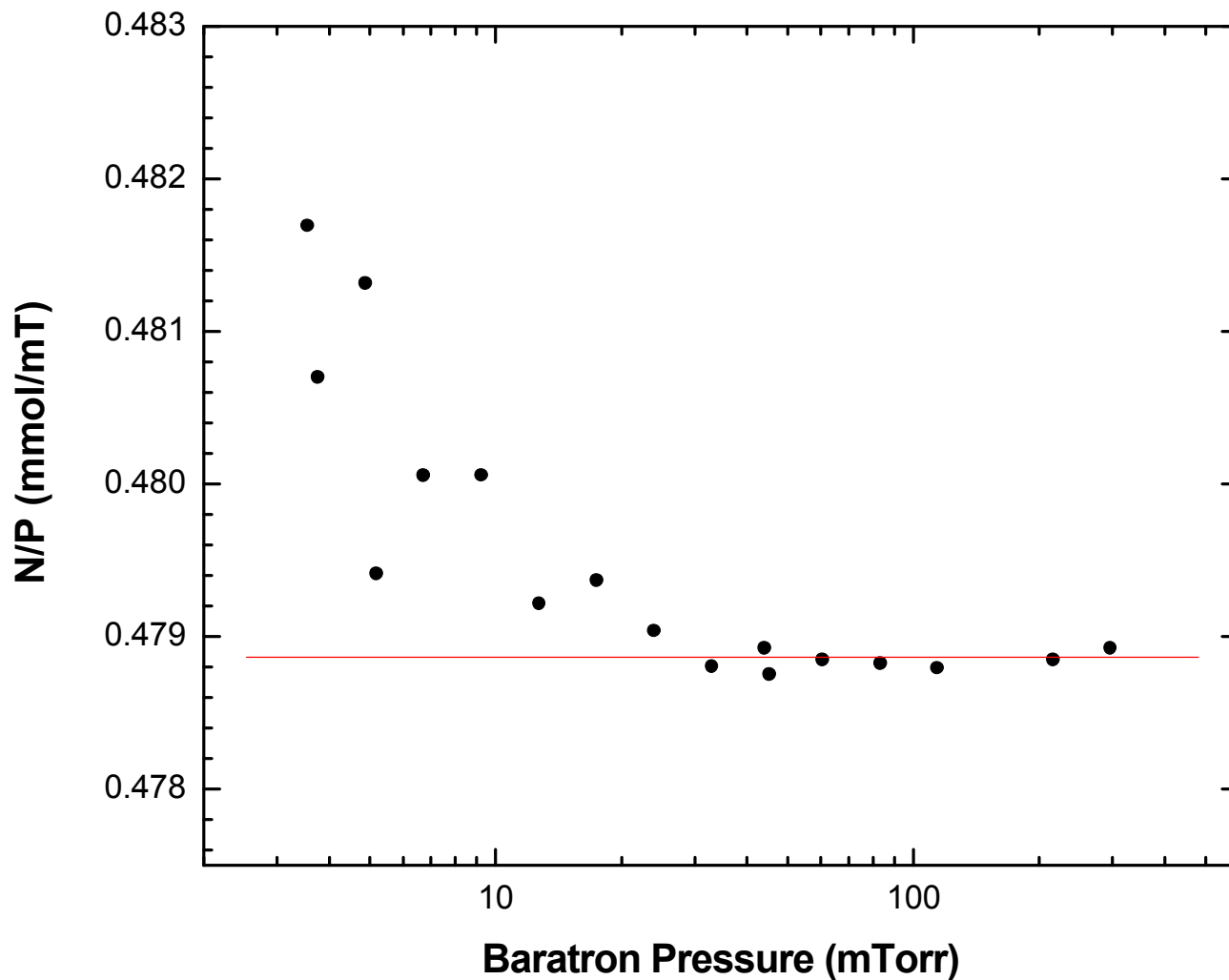

Extension of Range using Spinning Rotor Gauge

MS-1 N/P Function F+E

