

# ADDRESSING HYDROGEN EMBRITTLEMENT OF METALS IN THE SAE J2579 FUEL CELL VEHICLE TANK STANDARD

Somerday, B.P.<sup>1</sup> and Sloane, C.S.<sup>2</sup>

<sup>1</sup> Sandia National Laboratories, PO Box 969, Livermore, CA, 94550, USA, bpsomer@sandia.gov

<sup>2</sup> SloaneSolutions, LLC, Kewadin, MI, 49648, USA, chrissloane1@gmail.com

## ABSTRACT

The SAE Technical Information Report (TIR) J2579 (“Technical Information Report for Fuel Systems in Fuel Cell and Other Hydrogen Vehicles”) has been created to address the safety performance of hydrogen storage and handling systems on vehicles. Safety qualification of the compressed hydrogen storage system is demonstrated through performance testing on prototype containment vessels. The two performance tests currently included in the SAE J2579 for evaluating unacceptable leakage and burst do not account for the potential effects of hydrogen embrittlement on structural integrity. This report describes efforts to address hydrogen embrittlement of structural metals in the framework of performance-based safety qualification. New safety qualification pathways that account for hydrogen embrittlement in the SAE J2579 include an additional pneumatic performance test using hydrogen gas or materials tests that demonstrate acceptable hydrogen embrittlement resistance of candidate structural metals.

## 1.0 INTRODUCTION

Conventional liquid hydrocarbon-fueled vehicles have long-established safety measures as specified in the Society of Automotive Engineers (SAE) Recommended Practices and Standards. As vehicles with alternate fueling systems, i.e., compressed hydrogen, progress from concept to product, new guidance on the design and safety qualification of these fueling systems must be provided to vehicle developers. The SAE Technical Information Report (TIR) J2579 (“Technical Information Report for Fuel Systems in Fuel Cell and Other Hydrogen Vehicles”) has been created to address the safety performance of hydrogen storage and handling systems on vehicles.

One primary focus in the SAE J2579 is the compressed hydrogen storage system (CHSS), which consists of the high-pressure containment vessel(s) as well as the components that isolate high-pressure hydrogen from the remainder of the fuel system and the environment, e.g., the thermally-activated Pressure Relief Device(s) (TPRDs), valve(s), and associated fittings and fuel lines (Figure 1). The SAE J2579 applies to CHSS designed for Nominal Working Pressures (NWP) up to 70 MPa.

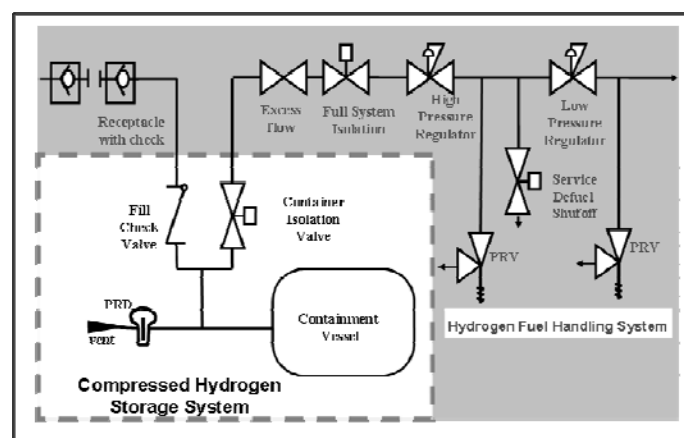

Figure 1. Schematic showing the compressed hydrogen storage system (CHSS) boundary as defined by the interfaces that isolate stored high pressure hydrogen.

The methodology for safety qualification of the CHSS is based on performance testing. The performance testing approach involves subjecting design prototypes to the demands of expected on-road conditions as well as extreme conditions, including the pressure and temperature cycles associated with driving and fueling, prolonged static pressure during parking, in-use impacts, exposure to chemicals, temperature extremes, and pressure excursions. The performance tests are evaluated based on the criteria that the CHSS must exhibit acceptable leakage and no rupture. Schematics summarizing the protocols for the expected service performance test (conducted pneumatically with hydrogen gas) and the durability performance test (conducted hydraulically) are in Figure 2.

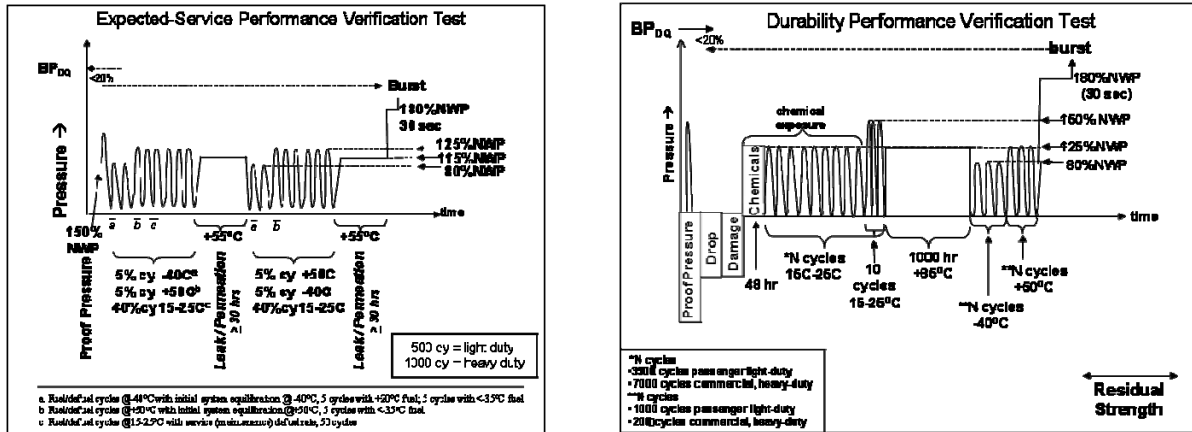

Figure 2. Schematics showing protocols for the expected service performance test (pneumatic) and the durability performance test (hydraulic).

One recognized safety issue associated with structural metals in hydrogen containment components is the phenomenon of hydrogen embrittlement. Compressed hydrogen containment vessels include structural metal components in both Type 3 and Type 4 designs. One important manifestation of hydrogen embrittlement in structural metals is enhanced susceptibility to crack propagation under quasi-static or cyclic stresses, which compromises structural integrity (i.e., degrades component durability). The performance tests currently included in SAE J2579 (Figure 2) do not capture the possible effect of hydrogen embrittlement on structural integrity. While one objective of the durability performance test is to evaluate structural integrity of the containment vessel, this test is conducted using hydraulic fluid and not hydrogen gas. Thus, there is currently a need in the SAE J2579 to address hydrogen embrittlement susceptibility of structural metals within the framework of performance test-based safety qualification.

The objective of this report is to describe in-progress efforts to address hydrogen embrittlement of structural metals in the SAE J2579. Methods for evaluating hydrogen embrittlement must be compatible with the performance test-based approach of SAE J2579.

## 2.0 LOGIC FLOW FOR ADDRESSING HYDROGEN EMBRITTLEMENT IN SAE J2579

A logic diagram depicting the decision process for addressing hydrogen embrittlement in the SAE J2579 is shown in Figure 3. As emphasized previously, safety qualification of the CHSS is conducted *via* performance testing. The ultimate decision represented in the logic diagram is whether structural integrity is evaluated using the hydraulic performance test only (Figure 2) or the hydraulic performance test plus an additional pneumatic performance test using hydrogen gas. In the latter case, the pneumatic test is not the one illustrated in Figure 2; rather, an additional pneumatic procedure has been developed to specifically address hydrogen embrittlement. This new durability test to evaluate hydrogen embrittlement is described in a later section.

Instead of requiring that every containment vessel design be subjected to the additional pneumatic test for evaluating the effect of hydrogen embrittlement on durability, two other conditions can be considered that allow the tank design to be exempted from the hydrogen embrittlement durability test. These exemptions were included since the same degree of safety could be achieved while providing the vehicle developer different qualification pathways.

The first exemption to the hydrogen embrittlement durability test is represented by the upper-left logic diagram box in Figure 3. In this case, the durability performance of containment vessels with metal components fabricated from aluminum alloy 6061 or stainless steel alloy 316 (>12 wt% nickel) can be assessed using the hydraulic test only. The rationale for requiring only one (hydraulic) durability test for containment vessels with 6061 aluminum or 316 stainless steel is two-fold. First, vehicle developers have accumulated operating experience with Type 3 and Type 4 compressed hydrogen containment vessels, indicating that the structural integrity of 6061 aluminum and 316 stainless steel components have not been compromised by hydrogen embrittlement. Second, crack propagation properties measured for 6061 aluminum demonstrate that this alloy is resistant to embrittlement in dry hydrogen gas [1, 2]. Laboratory data indicate that high-nickel 316 stainless steel is also resistant to hydrogen embrittlement at room temperature; however, these alloys become markedly more susceptible at temperatures near -50 °C [3]. Since the demands associated with vehicle driving and fueling may cause containment vessel components to experience sub-ambient temperatures, the stresses in 316 stainless steel components are restricted to the levels in containment vessels having a safe operating history, i.e., stress levels are limited to 40% of the maximum allowable stress (see Appendix B.2.3 in the SAE J2579).

The second exemption to the hydrogen embrittlement durability test is represented by the upper-right logic diagram box in Figure 3. This box refers to a series of material property tests that can be conducted on the structural metals considered for a containment vessel design. The objective of these tests is to demonstrate that the structural metal is effectively resistant to hydrogen embrittlement, independent of stress level, temperature, and hydrogen gas pressure. If results from tests on the structural metal meet the acceptance criteria, then the durability performance of containment vessels with these structural metals can be assessed using the hydraulic test only. These material tests are described in the next section.

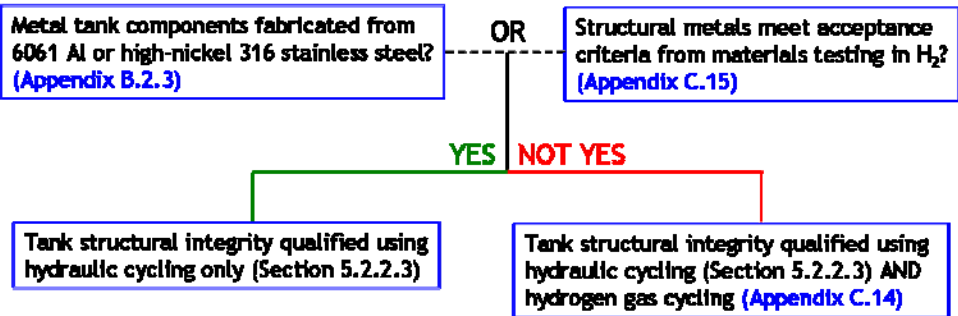

Figure 3. Logic diagram for addressing hydrogen embrittlement in the SAE J2579.

### 3.0 MATERIALS TESTING IN SAE J2579

As described in the previous section, the ultimate decision represented in the logic diagram (Figure 3) is whether structural integrity of the containment vessel is evaluated using the hydraulic performance test only or the hydraulic performance test plus a new pneumatic performance test using hydrogen gas. One pathway to this decision point involves conducting materials tests on the structural metals in the containment vessel design. If results indicate that a structural metal has acceptable hydrogen embrittlement resistance, then the structural integrity (i.e., durability) of the containment vessel can be evaluated from the hydraulic performance test only. (The metals identified in Appendix B.2.3, e.g.,

6061 aluminum, are already classified as resistant to hydrogen embrittlement under the specified constraints.) Otherwise, the containment vessel prototype must be subjected to both the hydraulic durability test as well as the hydrogen embrittlement durability test.

The first of four materials tests (described in Appendix C.15 of SAE J2579) is the slow strain rate tensile test in hydrogen gas. This test is a well-established method for evaluating the embrittlement susceptibility of structural metals in hydrogen gas and is documented in the ASTM Standard G142 [4]. The procedure for conducting this test essentially involves monotonic straining of a cylindrical tensile specimen in high-pressure hydrogen gas (Figure 4a). A maximum strain rate is prescribed to ensure that the kinetic steps for hydrogen uptake into the metal have sufficient time to proceed. Tests are conducted at two temperatures (i.e., -50 °C and 20 °C) and at one hydrogen gas pressure equal to the NWP of the containment vessel design. The two test temperatures (-50 °C and 20 °C) are specified since hydrogen embrittlement depends on temperature, and one of these temperatures typically corresponds to maximum embrittlement in common structural metals [5]. The metric for hydrogen embrittlement from the slow strain rate tensile test is the reduction of area (RA) at fracture. The acceptance criterion from this test is based on the ratio of the RA measured in hydrogen gas ( $RA_{H_2}$ ) and the RA measured in air ( $RA_{air}$ ). If this relative reduction of area (RRA, i.e.,  $RA_{H_2}/RA_{air}$ ) is greater than 0.7 at both test temperatures, then the material has acceptable hydrogen embrittlement resistance based on this test. From a design and safety perspective, the RRA provides a measurement of the material resistance to overload rupture in hydrogen gas.

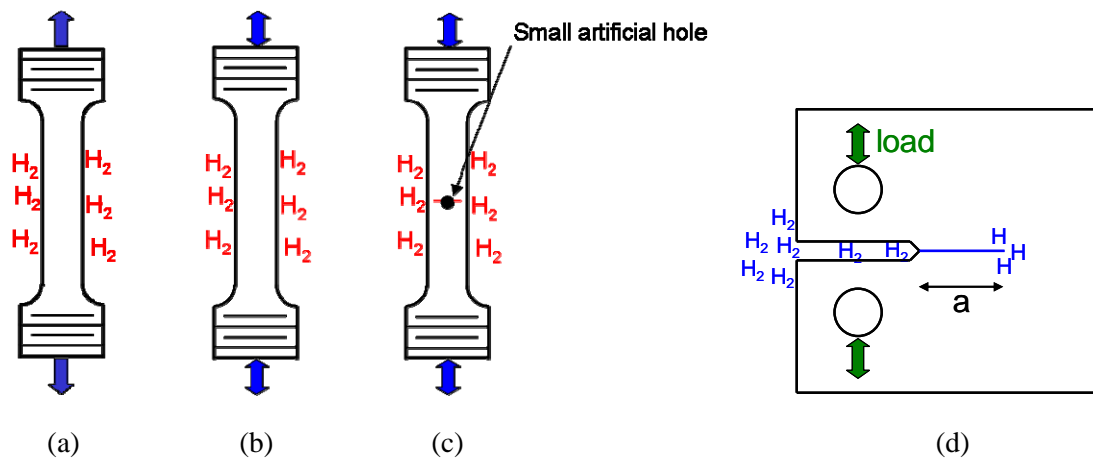

Figure 4. Schematics of materials test specimens in Appendix C.15 of SAE J2579. The slow strain rate specimen (a) is subjected to monotonic loading, while the fatigue life specimens (b) and (c) as well as the fatigue crack growth rate specimen (d) are tested under cyclic loading.

Two of the materials tests in Appendix C.15 of SAE J2579 are based on fatigue life test methods. These tests are conducted in a similar manner, i.e., a constant cyclic stress range is applied to a cylindrical specimen until failure results. The number of cycles to failure ( $N$ ) is measured as a function of the applied cyclic stress amplitude ( $S$ ), and this locus of data points is typically plotted as the “S-N curve” (Figure 5). The procedures for this fatigue life testing essentially follow ISO Standard 11782-1 [6], but one set of specimens must be tested in hydrogen gas. One of the constraints imposed on this testing in the SAE J2579 is that the selected cyclic stress amplitudes,  $S$ , must yield at least one data point with cycles to failure between  $10^3$  and  $10^4$ . This critical range of stress cycles reflects the number of fueling/de-fueling cycles in the containment vessel design. The test temperature is identified from the slow strain rate tensile testing results, i.e., the temperature (-50 °C or 20 °C) that yielded the lower RRA value is selected as the temperature for fatigue life testing. Testing in hydrogen gas is conducted at a pressure equal to the NWP of the container vessel design.

The two fatigue life tests in the SAE J2579 are differentiated by the specimen design. In one case, the specimen is cylindrical with smooth surfaces (Figure 4b), similar to the specimen in the slow strain

rate test (Figure 4a). In the other fatigue life test, the specimen is cylindrical, but a shallow, small-diameter hole is drilled into the surface (Figure 4c). These specimens emphasize two different stages of fatigue cracking. The specimen with the smooth surface is intended to evaluate fatigue crack initiation, i.e., the number of cycles to failure,  $N$ , is comprised primarily of the number of cycles for crack initiation. In contrast, fatigue crack initiation is facilitated by the drilled hole in the other specimen, so that the number of cycles to failure in this specimen principally reflects the number of cycles for crack growth [7]. Hydrogen embrittlement may affect fatigue crack initiation and fatigue crack growth differently [8], so both stages of fatigue cracking must be evaluated to confidently conclude that a structural metal is resistant to hydrogen embrittlement.

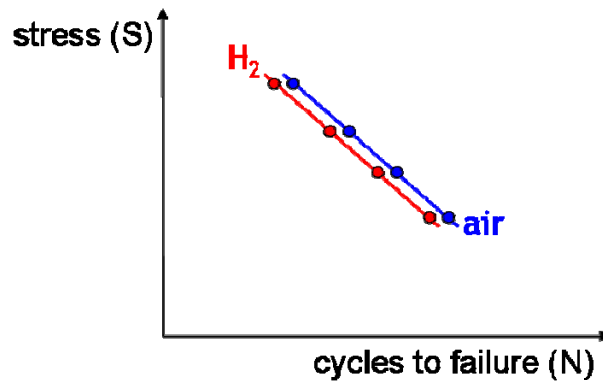

Figure 5. Schematic of the cyclic stress amplitude ( $S$ ) vs number of cycles to failure ( $N$ ) plots measured in hydrogen gas and in air. These  $S$ - $N$  data points are typically plotted on linear-log axes, since  $N$  changes by orders of magnitude.

There are several outstanding issues related to fatigue life testing parameters. First, similar to the slow strain rate tensile test, the loading rate in the fatigue life test must be specifically defined. In the case of the fatigue life test, this loading rate is the load-cycle frequency. It is well known that fatigue cracking is systematically enhanced as load-cycle frequency decreases [9], until a critical frequency is reached at which the severity of fatigue cracking reaches a plateau level. Ideally, fatigue life testing is conducted at the frequency delimiting the onset of this plateau behaviour, since this frequency represents the best balance between test efficiency and data reliability. However, this test frequency likely depends on several factors, including the structural metal system, so prescribing this variable remains an outstanding issue in the SAE J2579. Another unresolved issue is specifying the load ratio ( $R$ ), i.e., ratio of minimum stress to maximum stress, in the cyclic stress profile during fatigue life testing. Several values for the  $R$  ratio have been proposed based on containment vessel operating conditions, such as  $R = 0.1$  (represents the ratio of minimum pressure to maximum pressure) and  $R = -1$  (represents the presence of compressive residual stresses in Type 3 liners). Since it is reasonable to presume that the  $R$  ratio affects the severity of hydrogen embrittlement, the  $R$  ratio must be specifically addressed in the SAE J2579. Finally, the acceptance criterion for hydrogen embrittlement resistance has not been finalized for the fatigue life tests. As depicted in Figure 5, acceptable hydrogen embrittlement implies near-coincidence of the  $S$ - $N$  curves measured in hydrogen gas and in air, but a quantified acceptance criterion is still under development.

The final materials test in Appendix C.15 of SAE J2579 is intended to evaluate fatigue crack growth rate. Although the fatigue life test with the drilled-hole specimen is also designed to promote fatigue crack growth, the test inherently involves the growth of physically small cracks. In contrast, the fatigue crack growth rate specimen (Figure 4d) is designed to quantify the behaviour of “long cracks”, i.e., cracks that can be characterized using continuum fracture mechanics methods. Distinguishing “short cracks” from “long cracks” can be important, since crack growth rate under the same nominal stress can depend on crack size [10]. Considering metal components in containment vessels, cracks in Type 3 liners may be considered “short” since these components have modest thickness dimensions,

while cracks in the boss of Type 4 vessels may be considered “long” since these components have relatively thick dimensions.

The fatigue crack growth rate test is conducted following the basic procedures in ASTM Standard E647 [11], although one set of specimens is tested in hydrogen gas. The material response measured in this test is the crack growth increment per load cycle ( $da/dN$ ) vs the stress-intensity factor range ( $\Delta K$ ), as depicted schematically in Figure 6. The testing parameters for the fatigue crack growth rate test are nearly identical to those for the fatigue life tests, i.e., the same hydrogen gas pressure, temperature, and load-cycle frequency can be used in the two test methods. For the fatigue crack growth test, the R ratio is specified as 0.1. The acceptance criterion for hydrogen embrittlement resistance is based on comparing the crack growth rate,  $da/dN$ , in hydrogen to the crack growth rate in air at a specific  $\Delta K$  level. This acceptance criterion is still under consideration.

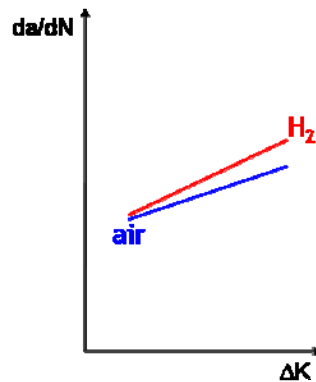

Figure 6. Schematic of fatigue crack growth rate ( $da/dN$ ) vs stress-intensity factor range ( $\Delta K$ ) relationships measured in hydrogen gas and in air.

#### 4.0 HYDROGEN EMBRITTLEMENT DURABILITY PERFORMANCE TEST

Figure 3 illustrates that durability performance testing can require only the hydraulic test when the structural metals are listed in Appendix B.2.3 (e.g., 6061 aluminum) or when materials testing (Appendix C.15) demonstrates that the metals have acceptable hydrogen embrittlement resistance. If these conditions are not satisfied, then qualification of containment vessel structural integrity is based on results from both the hydraulic performance test as well as a new pneumatic performance test designed to probe the effects of hydrogen embrittlement on structural integrity.

The hydrogen embrittlement performance test is described in Appendix C.14 of the SAE J2579. The objective of this test is to evaluate the propensity for hydrogen to promote fatigue crack initiation and growth in metal components, leading to possible rupture of the containment vessel. The test is conducted by subjecting a prototype containment vessel to pressure cycling with hydrogen gas. Although this test appears similar to the existing pneumatic expected-service performance test (Figure 2), the objectives of the two pneumatic tests are distinctly different. In particular, the pneumatic test described in Appendix C.14 is a durability performance test designed to assess the effects of hydrogen embrittlement on structural integrity. It must be noted that the pneumatic durability test in Appendix C.14 is not a substitute for the pneumatic expected-service test in Section 5.2.2.2. The expected-service performance test with hydrogen gas is conducted on all prototype containment vessels, but the durability performance test requirements depend on the conditions outlined in Figure 3.

The objective of the hydrogen embrittlement performance test is to demonstrate that a prototype containment vessel can endure pressure cycling in hydrogen gas without unacceptable leakage or rupture. The baseline number of pressure cycles for this performance test is the same as the hydraulic durability performance test, i.e.,  $N_D$ . In the hydrogen embrittlement durability test, the containment

vessel cannot exhibit unacceptable leakage within  $N_D$  cycles and cannot rupture within  $2 \times N_D$  cycles. Although the hydrogen embrittlement performance test is simple in concept (Figure 7), several testing parameters must be specified.

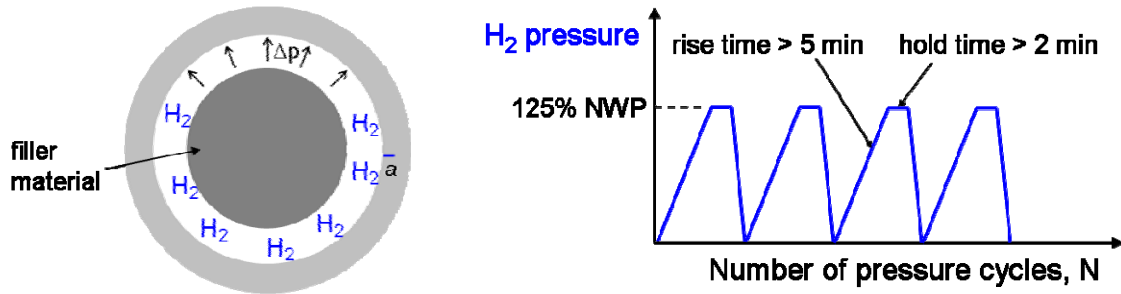

Figure 7. Schematic of hydrogen embrittlement performance test procedures.

Two variables that can significantly impact hydrogen-assisted fatigue crack initiation and growth are pressure-cycle profile and temperature. Considering the pressure-cycle profile, the minimum and maximum pressure levels are 2 MPa and 125% NWP, respectively. In addition, the rise time to maximum pressure requires a minimum of 5 minutes, and the maximum pressure must be maintained for a minimum of 2 minutes before the hydrogen gas is vented. The rationale for this pressure-cycle profile is based on data showing that hydrogen-accelerated fatigue crack growth depends on the structural stress-cycle frequency and perhaps the duration at maximum stress. Lower frequency is known to enhance fatigue crack growth rates in hydrogen gas [9]. Therefore, the pressure rise rate during the performance test must be restricted. Ideally, the pressure rise rate during the performance test would match the pressure rise rate during vehicle fueling. However, data suggest that a pressure rise rate during the performance test that is within a factor of 2 or 3 of the pressure rise rate during fueling will not lead to significant variations in hydrogen-accelerated fatigue crack growth in the respective containment vessels. Since fueling times for 70 MPa vessels are expected to range from 3 to 15 minutes, the pressure rise time during the performance test was set at 5 minutes. The hold-time duration of 2 minutes at maximum pressure was selected based on previous testing protocols for hydrogen cycling of steel tanks to evaluate hydrogen-accelerated fatigue crack growth [12].

Since the number of pressure cycles in the hydrogen embrittlement performance test can exceed 10,000, the cycles must be applied as efficiently as possible. This efficiency is principally attained by venting the hydrogen gas relatively rapidly after the hold at maximum pressure (Figure 7). However, rapid venting can lead to unrealistic conditions, such as excessively low temperatures. Pressure-cycle efficiency without detrimental consequences is enabled by filling most free volume in the prototype containment vessel with an inert material. This scheme of using filler material also promotes safety during testing, since less hydrogen gas is available during a potential release. While filler material allows the temperature in the prototype containment vessel to remain relatively constant, the containment vessel during operation has a temperature profile that reflects driving and fueling conditions as well as ambient temperatures. It is expected that the operating temperature in a containment vessel can reach  $-50\text{ }^{\circ}\text{C}$ , which can be a critical temperature for hydrogen embrittlement susceptibility. The performance test is thus conducted at both  $-50\text{ }^{\circ}\text{C}$  and  $20\text{ }^{\circ}\text{C}$  to ensure that the test probes worst-case conditions for hydrogen embrittlement. These test temperatures are the same as those in the slow strain rate tensile test (Section 3.0), since in both cases the rationale is to capture worst-case temperature conditions for hydrogen embrittlement.

## 5.0 CONCLUSIONS

The SAE Technical Information Report (TIR) J2579 (“Technical Information Report for Fuel Systems in Fuel Cell and Other Hydrogen Vehicles”) has been created to address the safety performance of hydrogen storage and handling systems on vehicles. Safety qualification of the compressed hydrogen

storage system is demonstrated through performance testing on prototype containment vessels. The two performance tests currently included in the SAE J2579 for evaluating unacceptable leakage or burst do not account for the potential effects of hydrogen embrittlement on structural integrity. An additional performance test designed to qualify the containment vessel against hydrogen-induced crack growth leading to leakage or burst has been developed in Appendix C.14 of the SAE J2579. This hydrogen embrittlement performance test is not required during safety qualification if one of the following conditions is satisfied: 1) the structural metals are widely accepted as resistant to hydrogen embrittlement (e.g., aluminum alloy 6061) or 2) a candidate structural metal is qualified as resistant to hydrogen embrittlement based on materials tests described in a new Appendix C.15.

## ACKNOWLEDGMENTS

Sandia is a multiprogram laboratory operated by Sandia Corporation, a wholly owned subsidiary of Lockheed Martin Corporation, for the U.S. Department of Energy's National Nuclear Security Administration under contract DE-AC04-94AL85000.

## 6.0 REFERENCES

1. Ohmiya, S. and Fujii, H., Fatigue Properties of Liner Materials Used for 35 MPa-Class On-Board Hydrogen Fuel Tanks, Proceedings of 2005 ASME Pressure Vessels and Piping Division Conference (PVP2005), Denver CO, USA, Paper No. PVP2005-71735.
2. Hagihara, A., Oda, Y., and Noguchi, H., Influence of Testing Frequency on Fatigue Crack Growth of 6061-T6 Aluminum Alloy in Hydrogen Gas Environment, *Key Engineering Materials*, **353-358**, 2007, pp. 174-177.
3. San Marchi, C., Michler, T., Nibur, K.A., and Somerday, B.P., On the Physical Differences Between Tensile Testing of Type 304 and 316 Austenitic Stainless Steels with Internal Hydrogen and in External Hydrogen, *International Journal of Hydrogen Energy*, **35**, 2010, pp. 9736-9745.
4. ASTM Standard G142, Standard Test Method for Determination of Susceptibility of Metals to Embrittlement in Hydrogen Containing Environments at High Pressure, High Temperature, or Both, ASTM International, West Conshohocken PA, USA, 2004.
5. San Marchi, C. and Somerday, B.P., Technical Reference on Hydrogen Compatibility of Materials, SAND2008-1163, Sandia National Laboratories, Livermore, CA USA, 2008.
6. ISO International Standard 11782-1, Corrosion of Metals and Alloys - Corrosion Fatigue Testing Part 1: Cycles to Failure Testing, International Organization for Standardization, Geneva, Switzerland, 1998.
7. Murakami, Y. and Miller, K.J., What is Fatigue Damage? A View Point from the Observation of Low Cycle Fatigue Process, *International Journal of Fatigue*, **27**, 2005, pp. 991-1005.
8. Noguchi, H., Effects of Hydrogen Gas Environment on Fatigue Characteristics, Proceedings of International Hydrogen Energy Development Forum Workshop, Kyushu University, Fukuoka, Japan, 2007, pp. 35-38.
9. Priest, A.H., Fatigue Crack Growth and Fracture Resistance of Steels in High-Pressure Hydrogen Environments, British Steel Corporation, Contract No. EHC-(1)42-012-81UK(H), Office for Official Publications of the European Communities, Luxembourg, 1983.
10. Suresh, S., Fatigue of Materials, Cambridge University Press, Cambridge UK, 1998, pp. 541-569.
11. ASTM Standard E647, Standard Test Method for Measurement of Fatigue Crack Growth Rates, ASTM International, West Conshohocken PA, USA, 2008.
12. Kesten, M. and Windgassen, K.-F., Hydrogen Effects in Metals (I.M. Bernstein and A.W. Thompson, Eds.), The Metallurgical Society of AIME, Warrendale PA, USA, 1981, pp.1017-1025.